

Modular integrated transportable substation (MITS)



Contents

Description	Page
Voltage regulation with bypassing	2
Mobile MITS application	3
Natural gas extraction	4
Utility substation	5
Portable power application	6
Small substation	7
Residential area substation	8
Lightning damaged substation	9
Rural substation.	10



Powering Business Worldwide

Voltage regulation with bypassing



Value proposition

Single-point contact for project management, plug-and-play installation, on-board fluid containment, and resolved voltage regulation with an aesthetically pleasing design.

A waste water treatment facility in the northeast United States found that poor voltage regulation was a significant problem for their equipment. The facility decided to remedy the situation with a voltage regulation MITS, resulting in fewer equipment issues and improved reliability.

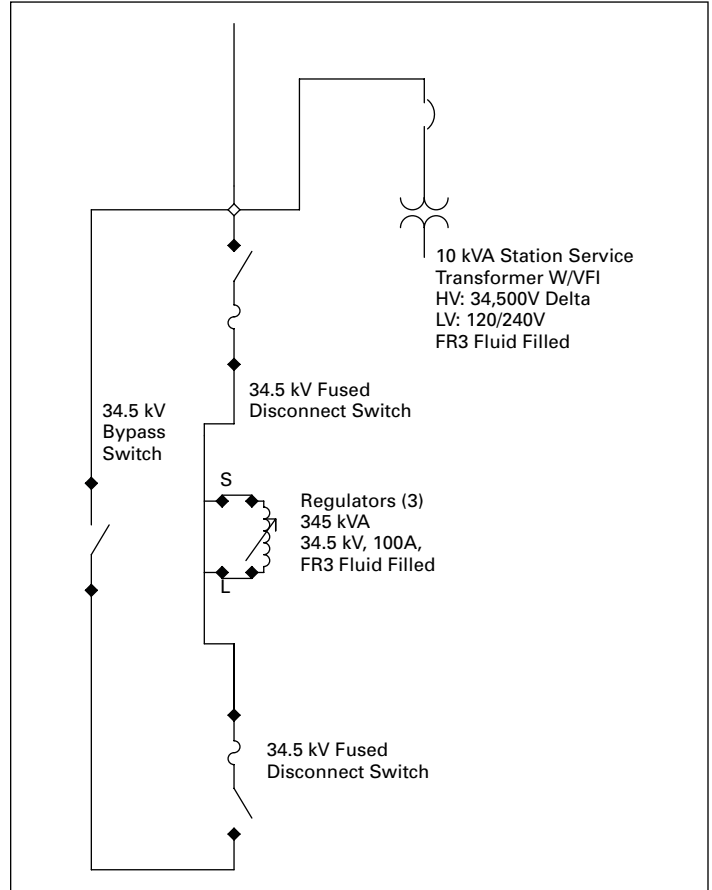

Figure 1. System Schematic

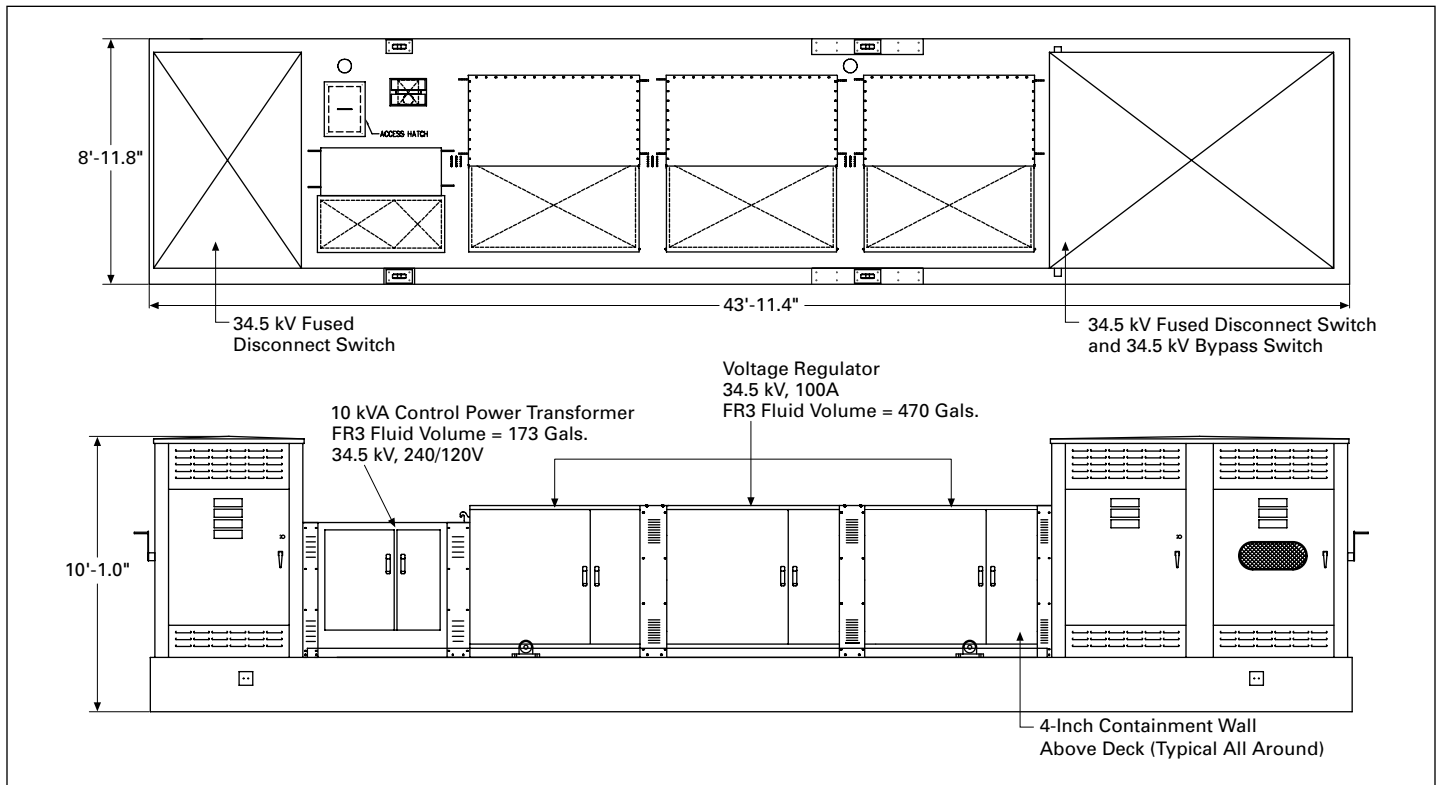

Figure 2. System Layout and Dimensions

Mobile MITS application



Value proposition

Improved reaction time in emergency situations, completely mobile, integrated connection interface, and simple design.

This application involves a dedicated mobile application for the customer. Fueled by the need to respond and react to potential emergency situations, this mobile MITS provides the customer the ability to transform voltage. Used in conjunction with a mobile genset, voltage is generated at 480V and stepped up to a voltage of either 4160Y/2400 or 2400V delta to supply power on an emergency basis.

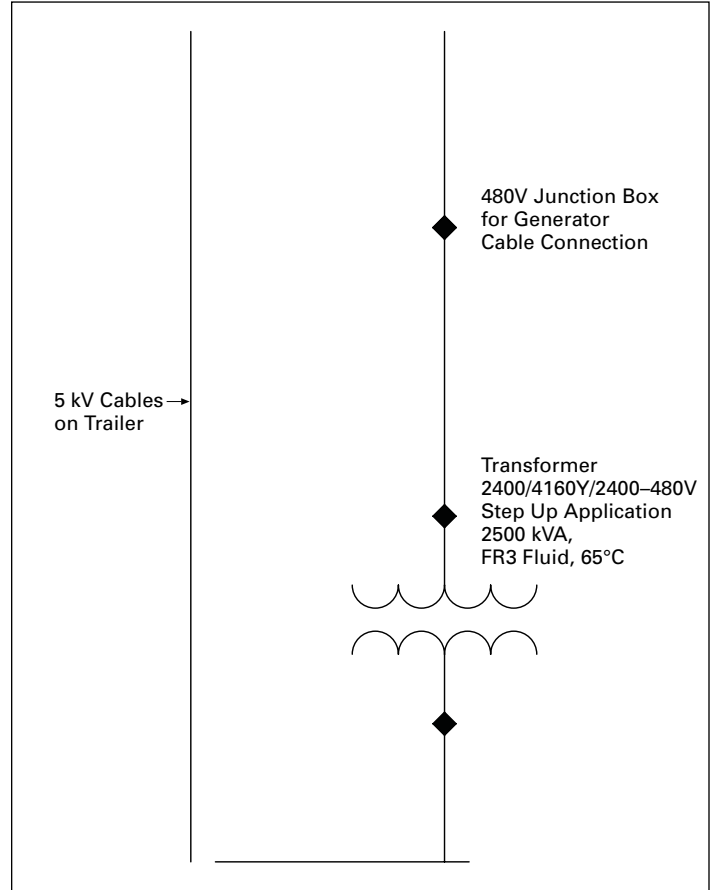

Figure 3. System Schematic

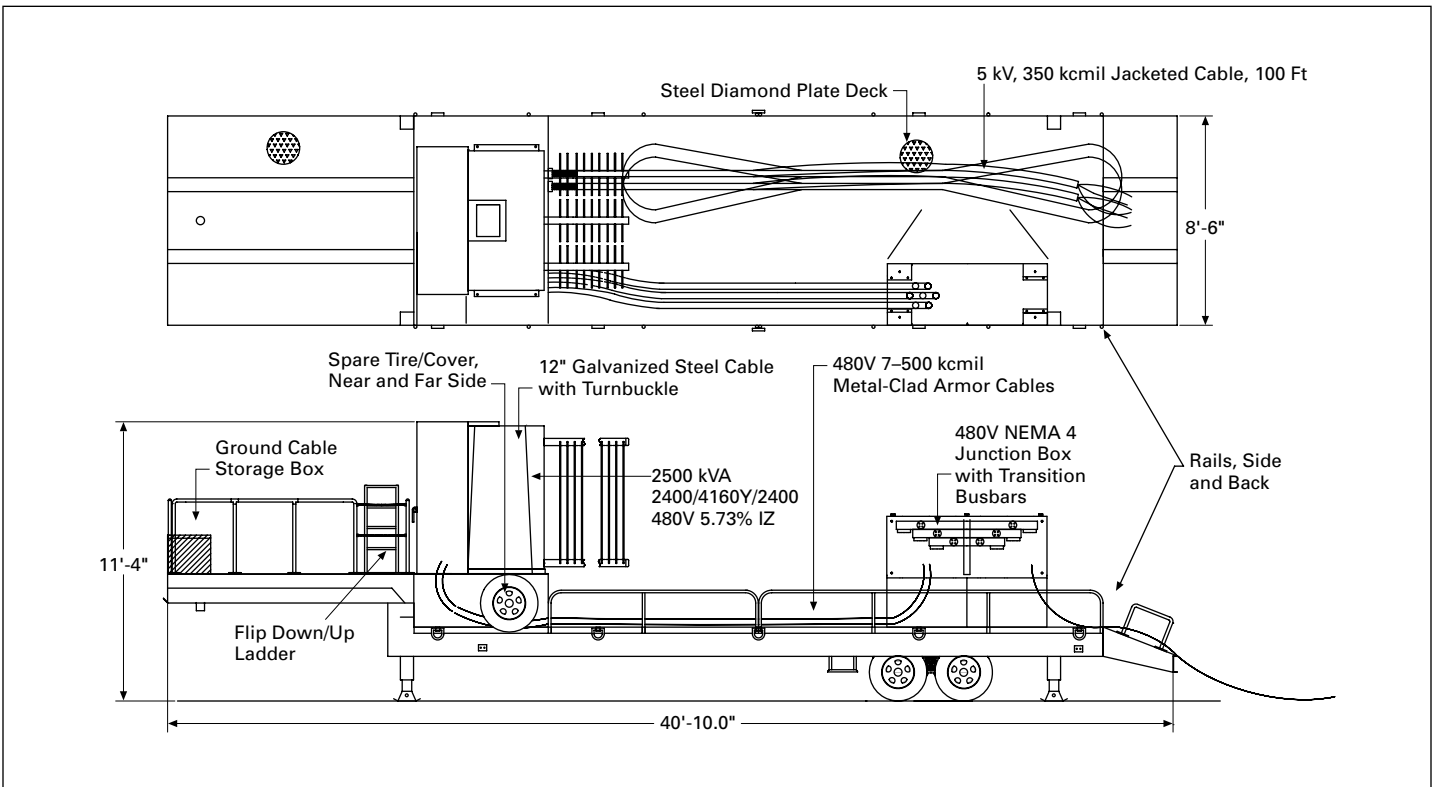

Figure 4. System Layout and Dimensions

Natural gas extraction



Value proposition

Fifty percent savings on future relocation costs, 15 percent savings over conventional design, 25 percent savings in space, and increase in cash flow due to a quickly commissioned substation.

Configured for supplying electrical loads for sites that extract ground water embedded with natural gas, this MITS application is a different way of building substations for the mining industry. Using a skid-based platform, the MITS reduces the footprint and can provide a cost savings over a typical installation. Eaton's modular substation is designed to be relocated to a new site after its service is completed at the existing site. The ability to move the entire substation without complete disassembly can provide customers with substantial benefits over conventional substation installations.

Viewing loads and status of equipment in harsh, remote environments often requires a long drive across difficult terrain. Eaton provides RTU cabinets populated with IEDs and SCADA equipment to meet most specifications. This contributes to cost and time savings for maintaining valuable equipment.

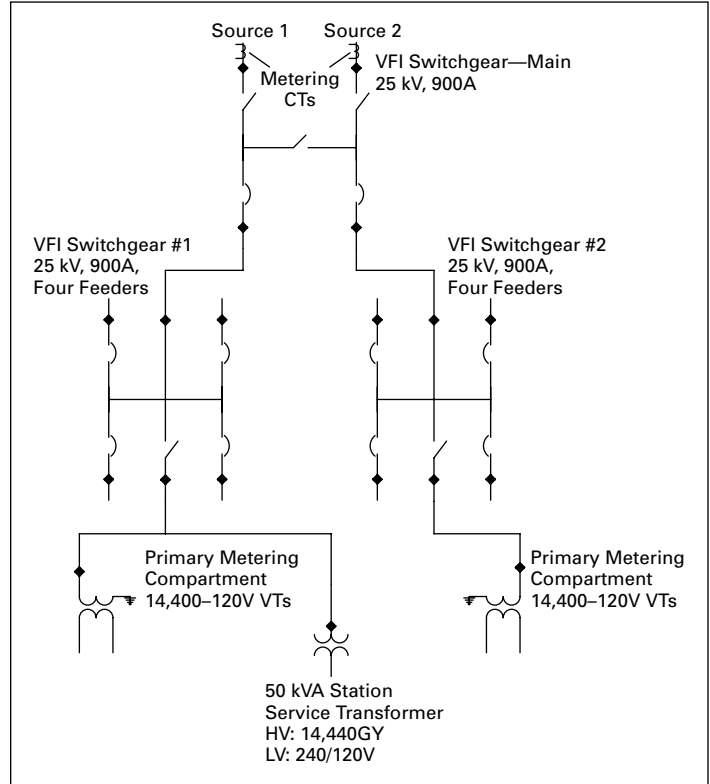

Figure 5. System Schematic

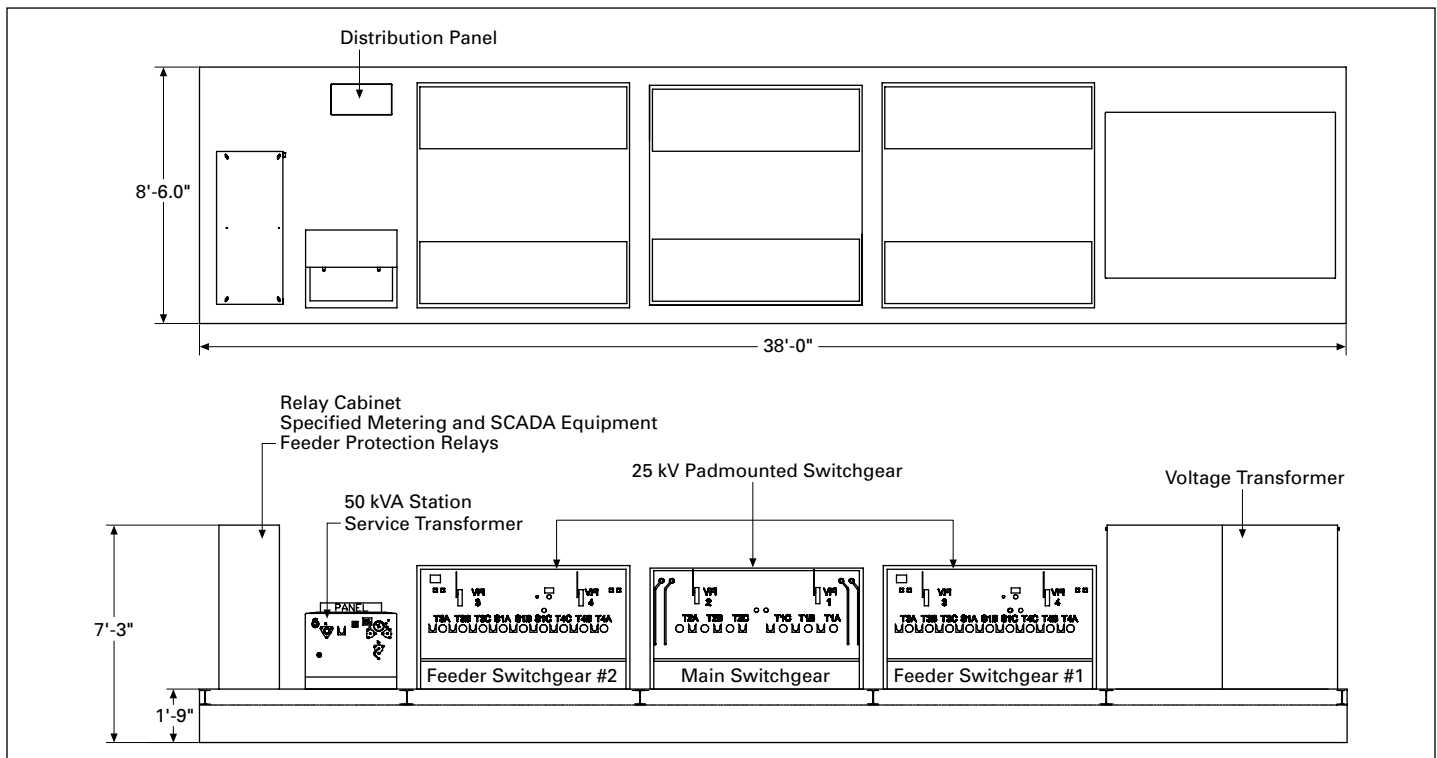

Figure 6. System Layout and Dimensions

Utility substation



Value proposition

Modular design can be used at many locations, is completely integrated, provides on-board spill containment, and is transportable.

Driven by the need to cut the cost of installed substations and to create a modular design concept, this customer turned to Eaton's MITS solution. The conventional substation consisted of overhead distribution, transformation, and feeder protection. In addition, each substation required the site to be prepared for oil containment in the event of a leak. In this example, Eaton provided solutions to the customer's requirements and allowed the use of this modular solution at several sites throughout the electrical grid.

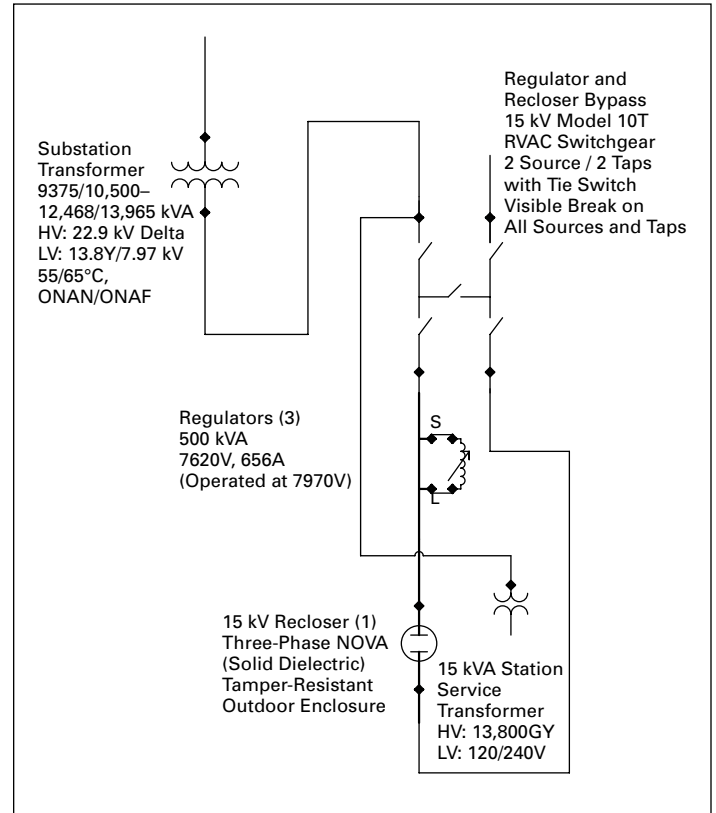

Figure 7. System Schematic

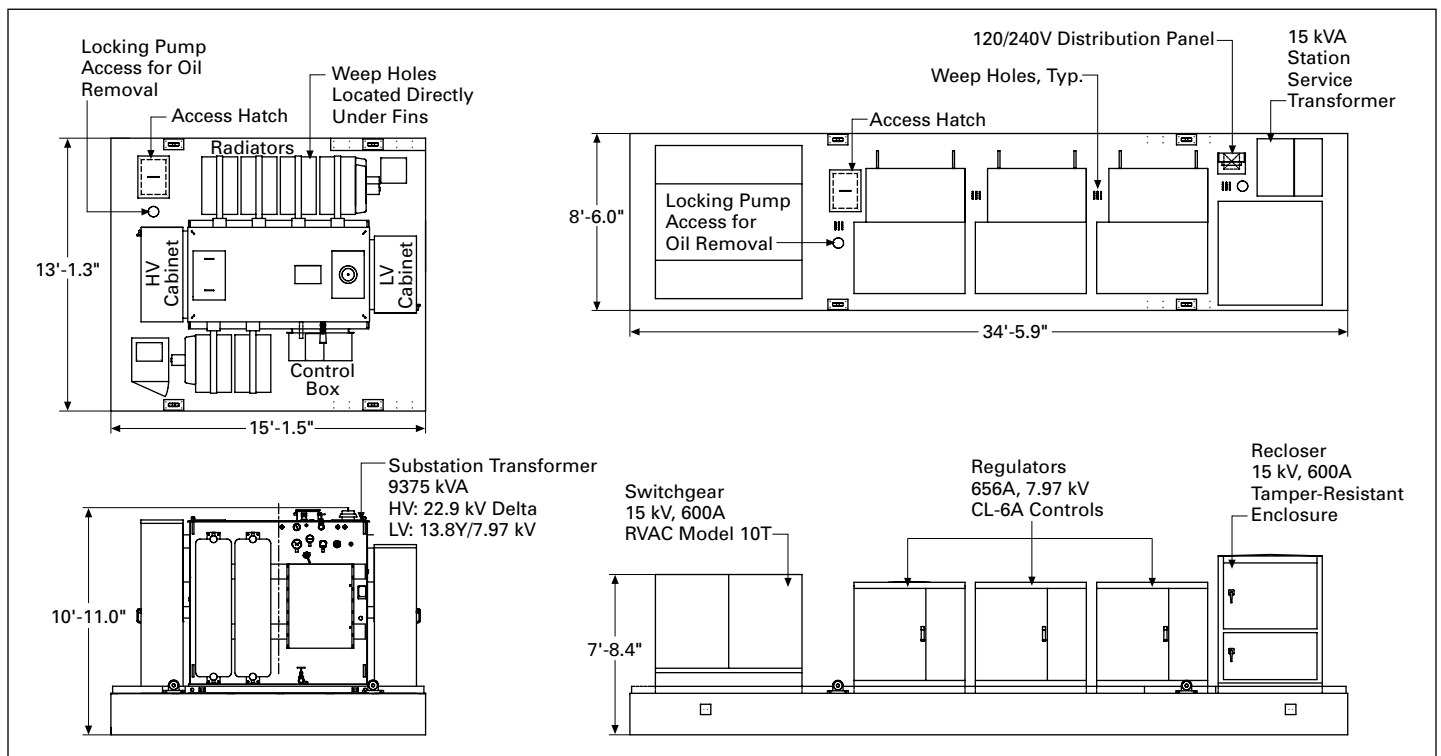

Figure 8. System Layout and Dimensions

Portable power application



Value proposition

Quick delivery, fully integrated, transportable, and a single point of contact for project management.

Furnished for the U.S. government, this MITS skid provides quick and reliable portable power for emergency applications. The need for this project was to step up voltage supplied by generators from 3.6 kV to 11 kV. The application has a variety of self-protecting features, and is quick to install and commission.

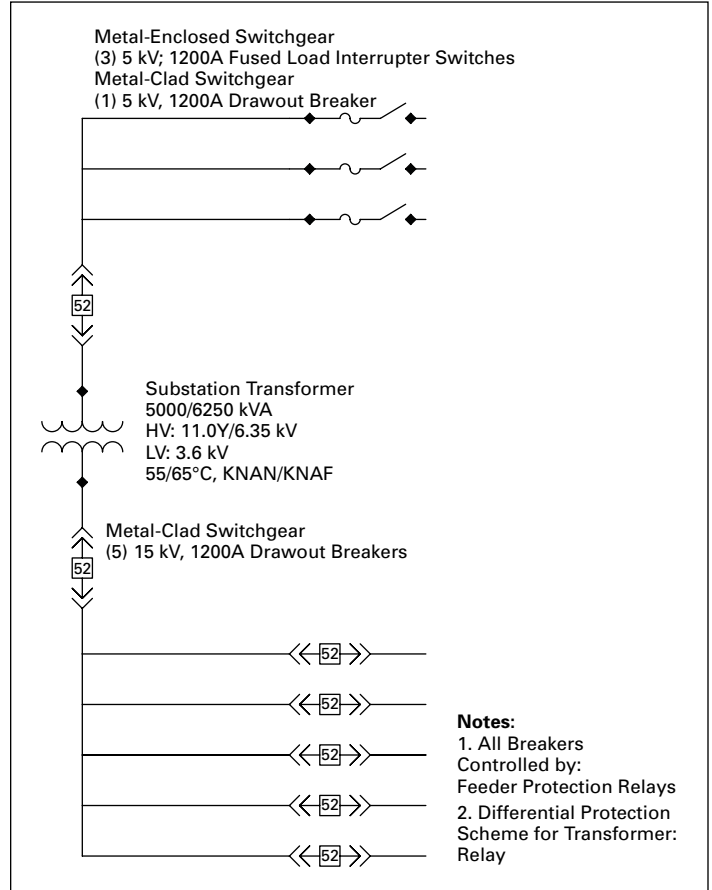

- Notes:**
1. All Breakers Controlled by: Feeder Protection Relays
 2. Differential Protection Scheme for Transformer: Relay

Figure 9. System Schematic

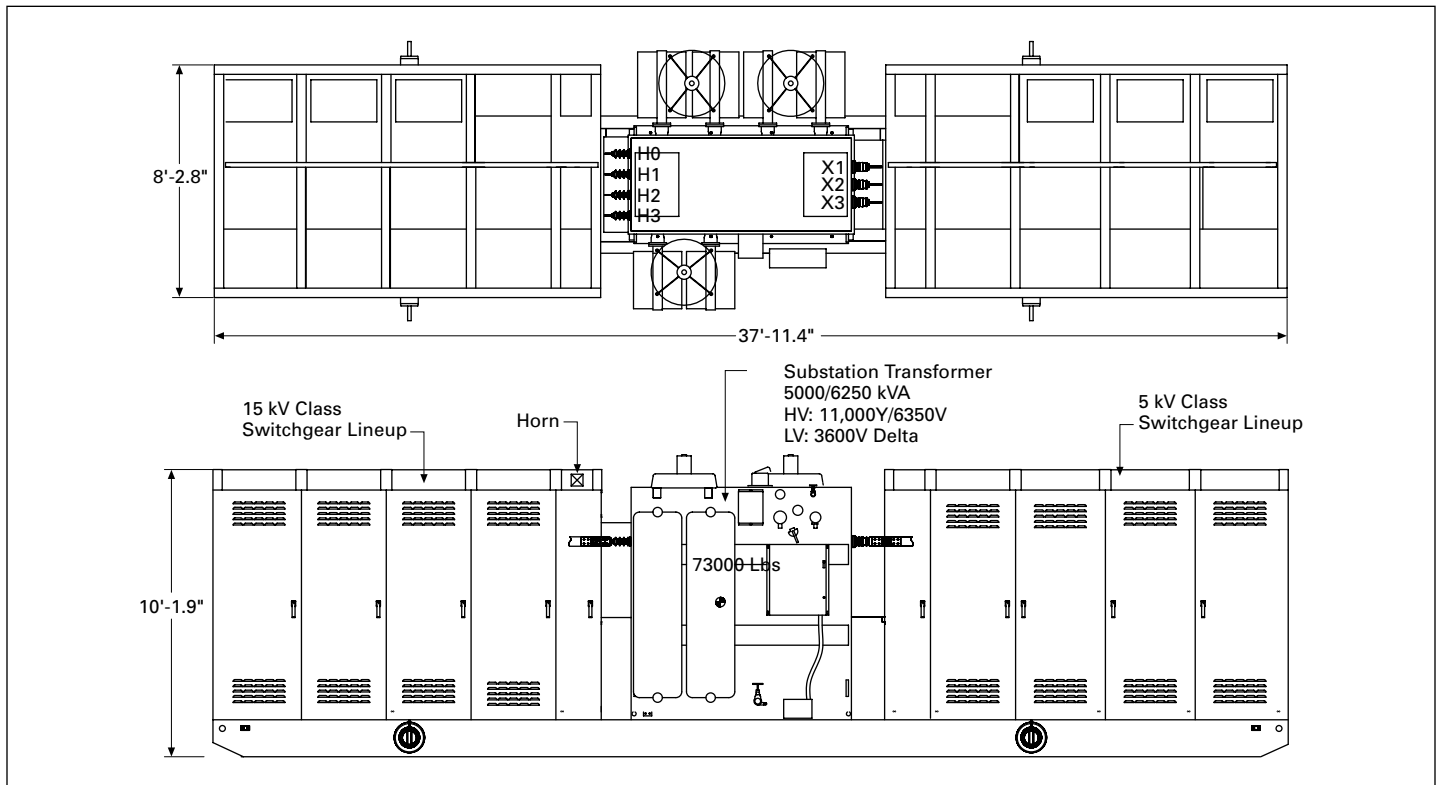

Figure 10. System Layout and Dimensions

Small substation



Value proposition

Substantial saving over conventional substation design, 25 to 30 percent savings in project management, and over 60 percent smaller footprint than conventional substation design.

Installed in the western part of the U.S., this application combines two MITS skids that will provide dual functionality. Initially, the skids will step up voltage from 13.2 kV to 34.5 kV, and distribute voltage onto the transmission lines. At some point in the future, the customer plans to use these skids in the reverse fashion and step 34.5 kV down to 13.2 kV. Included with each skid is an Eaton differential protection relay used to trip the NOVA recloser and an upstream device.

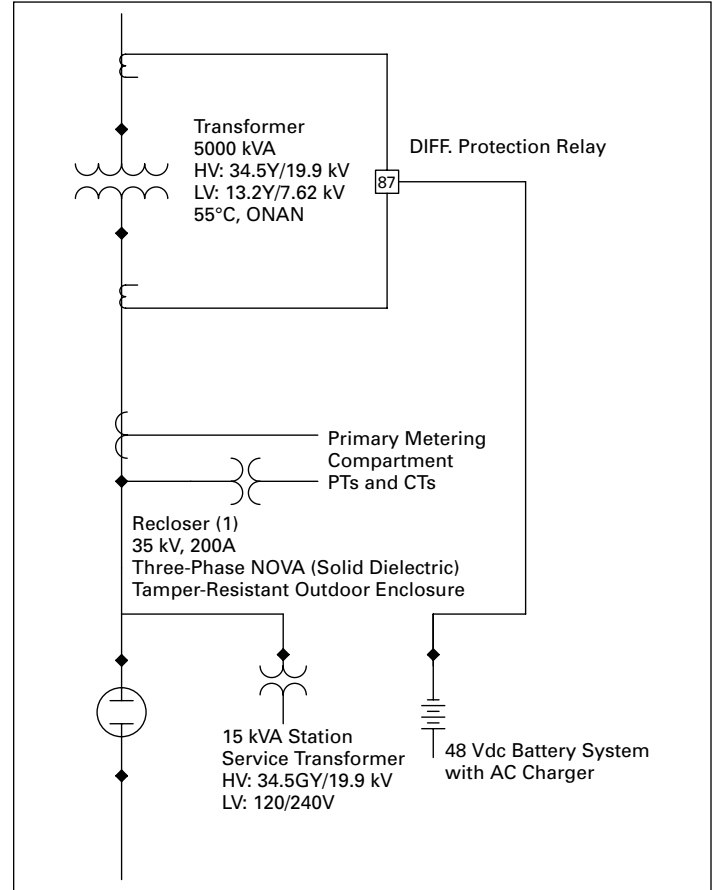

Figure 11. System Schematic

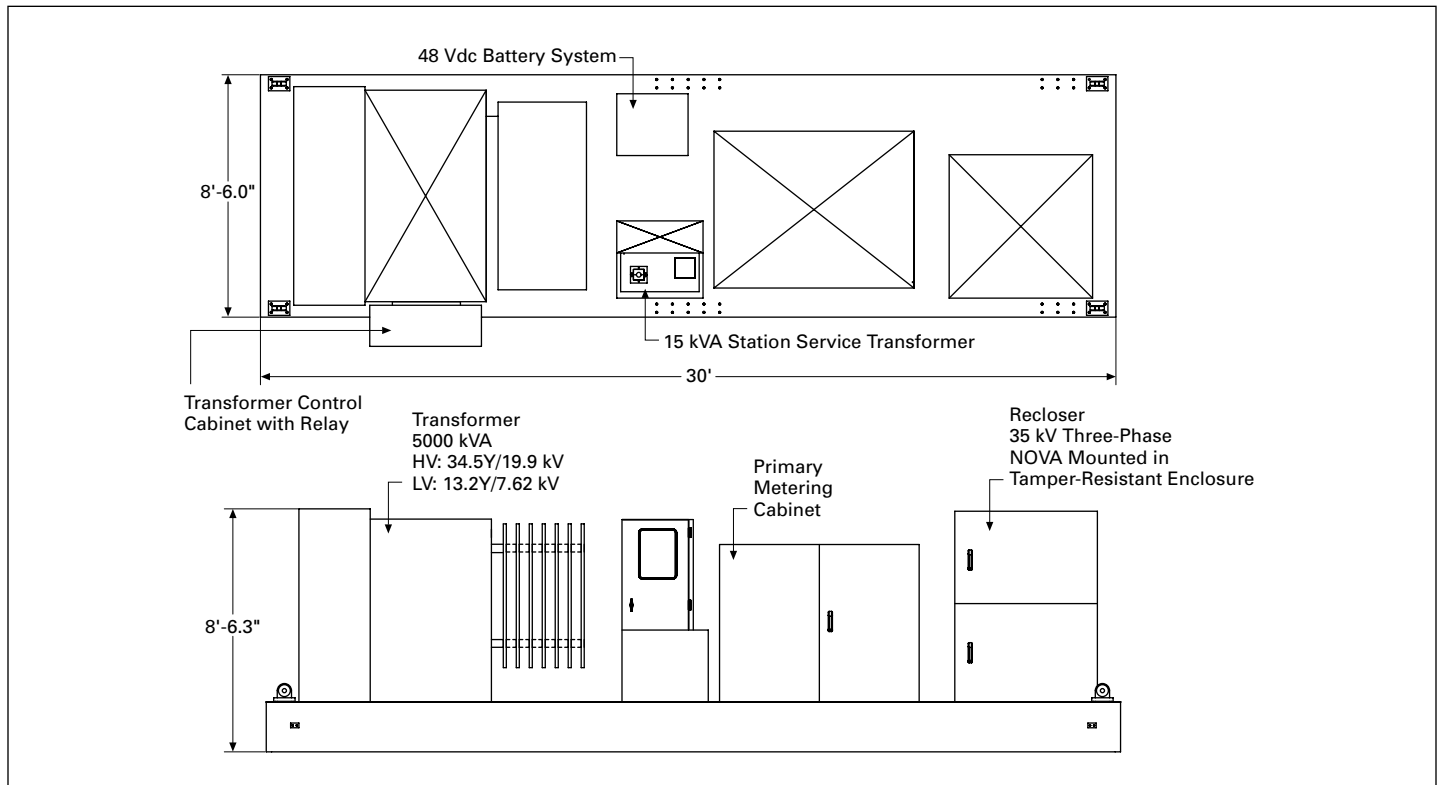

Figure 12. System Layout and Dimensions

Residential area substation



Value proposition

Significantly smaller footprint than conventional substation design, safe and secure design requires no fencing, and one point of contact for entire substation.

The heavily wooded terrain of a 13.2 kV to 4 kV metro area provided challenges to the utility that served local estate homes. Unit substations serving the area were several decades old, had become heavily loaded, and lacked needed and overlooked maintenance. A new Eaton MITS was the best option.

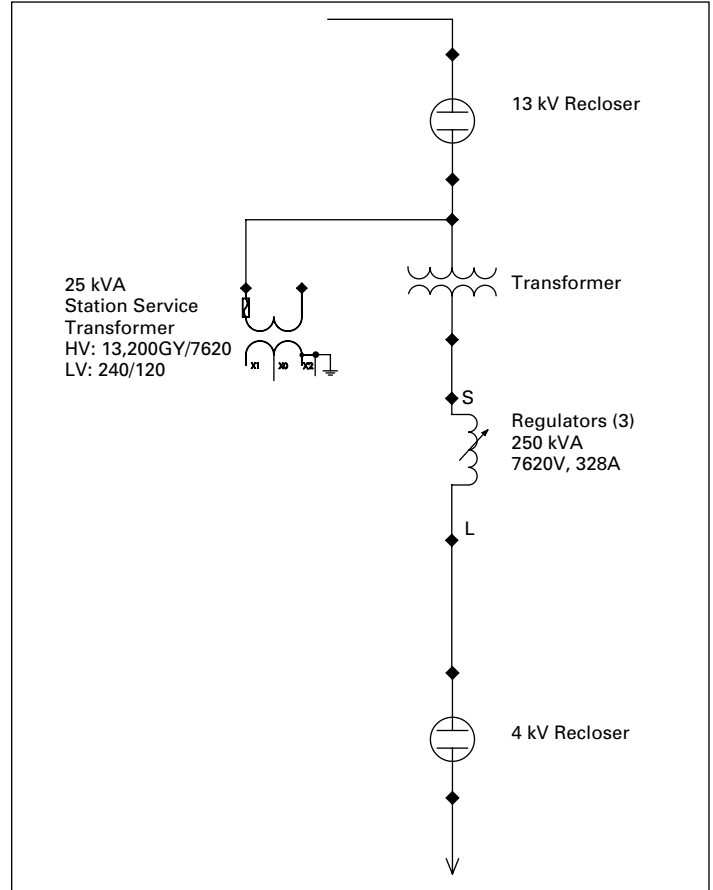

Figure 13. System Schematic

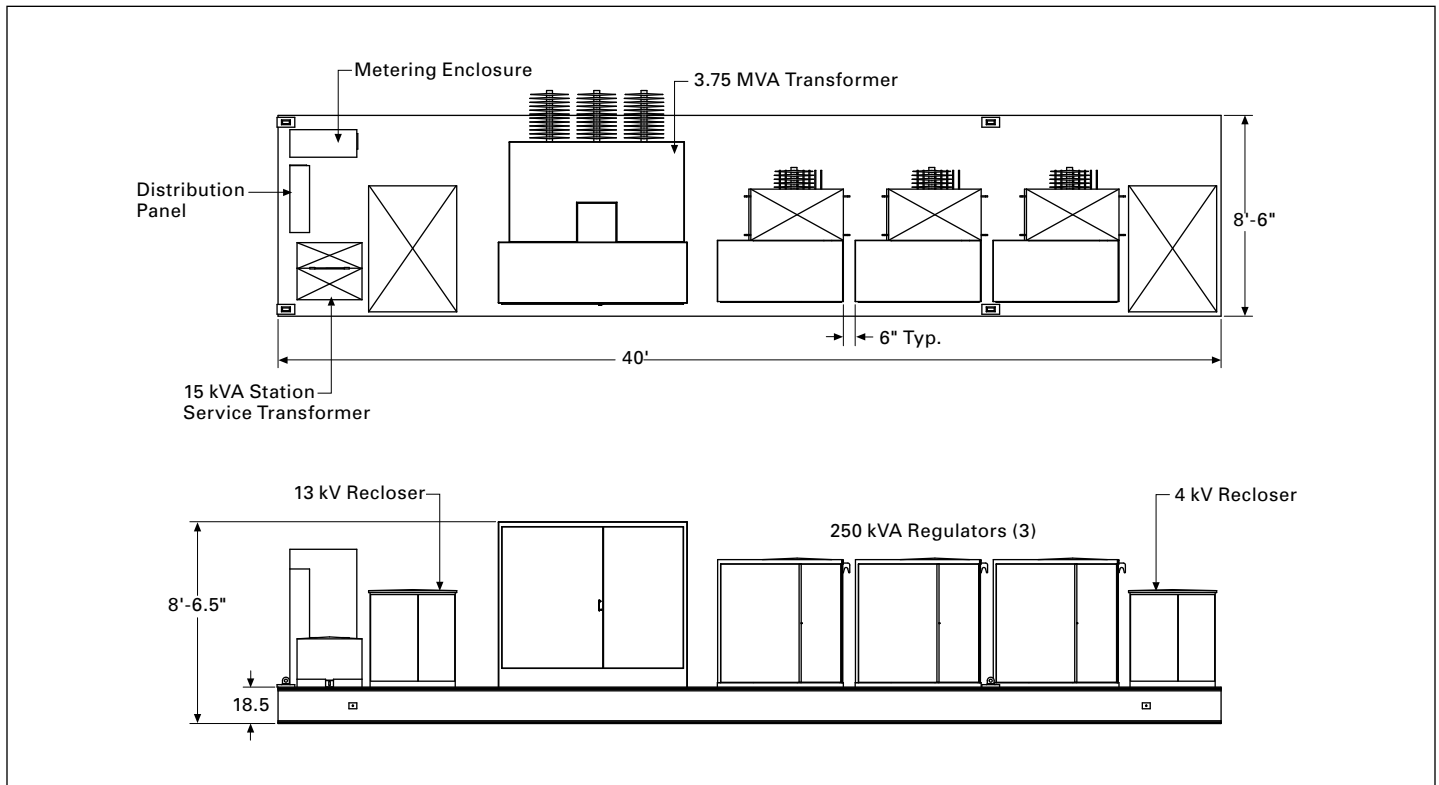
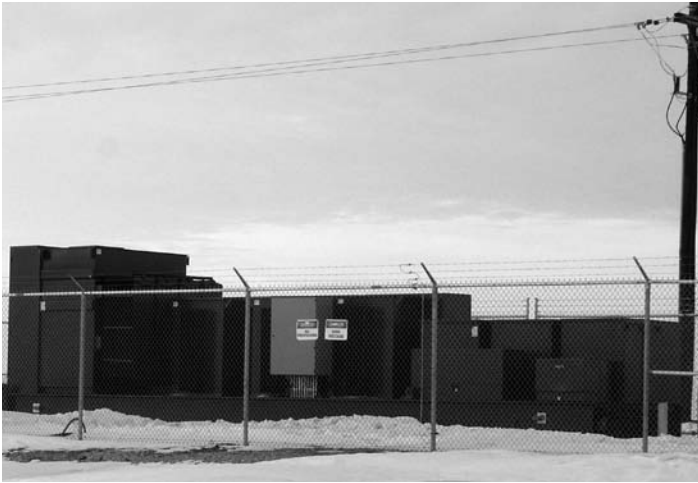

Figure 14. System Layout and Dimensions

Lightning damaged substation



Value proposition

Twenty-five percent savings on installed cost, and rapid and efficient installation and recovery time.

This design offers the perfect solution for a customer needing to replace a 5 MVA storm-damaged substation...fast. Eaton mounted and pre-wired a 5 MVA transformer, three pad-mounted regulators, a station service transformer, switchgear, and controls on a single structural steel platform. The customer pre-installed the ground grid, the MITS foundation, the incoming circuits, and the outgoing circuits. Total field install time of the MITS assembly was less than four hours.

Power to a town and surrounding community was restored in record time, and at a total installed cost 25 percent below conventional methods.

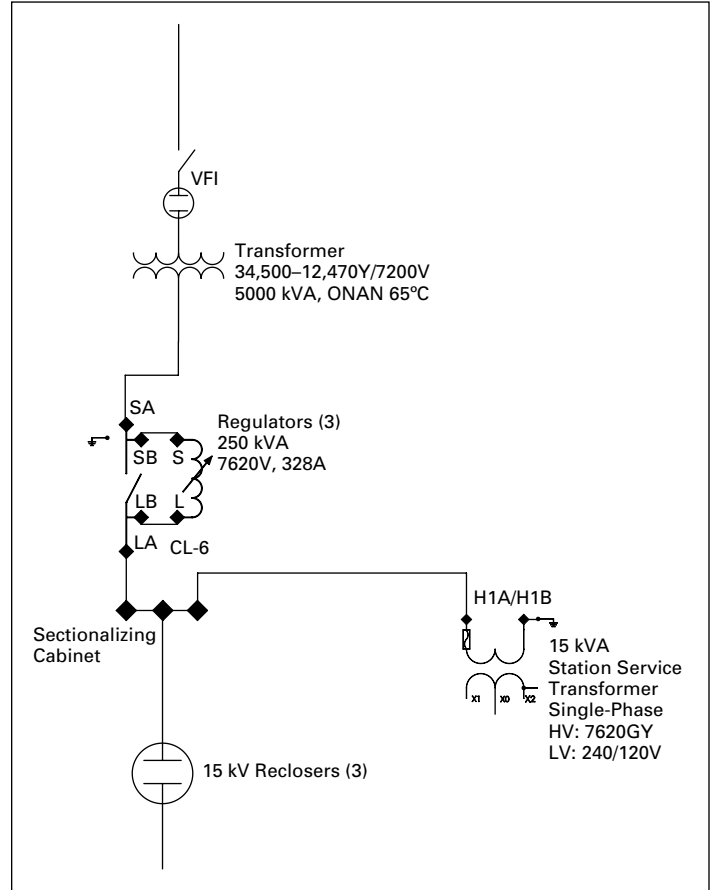

Figure 15. System Schematic

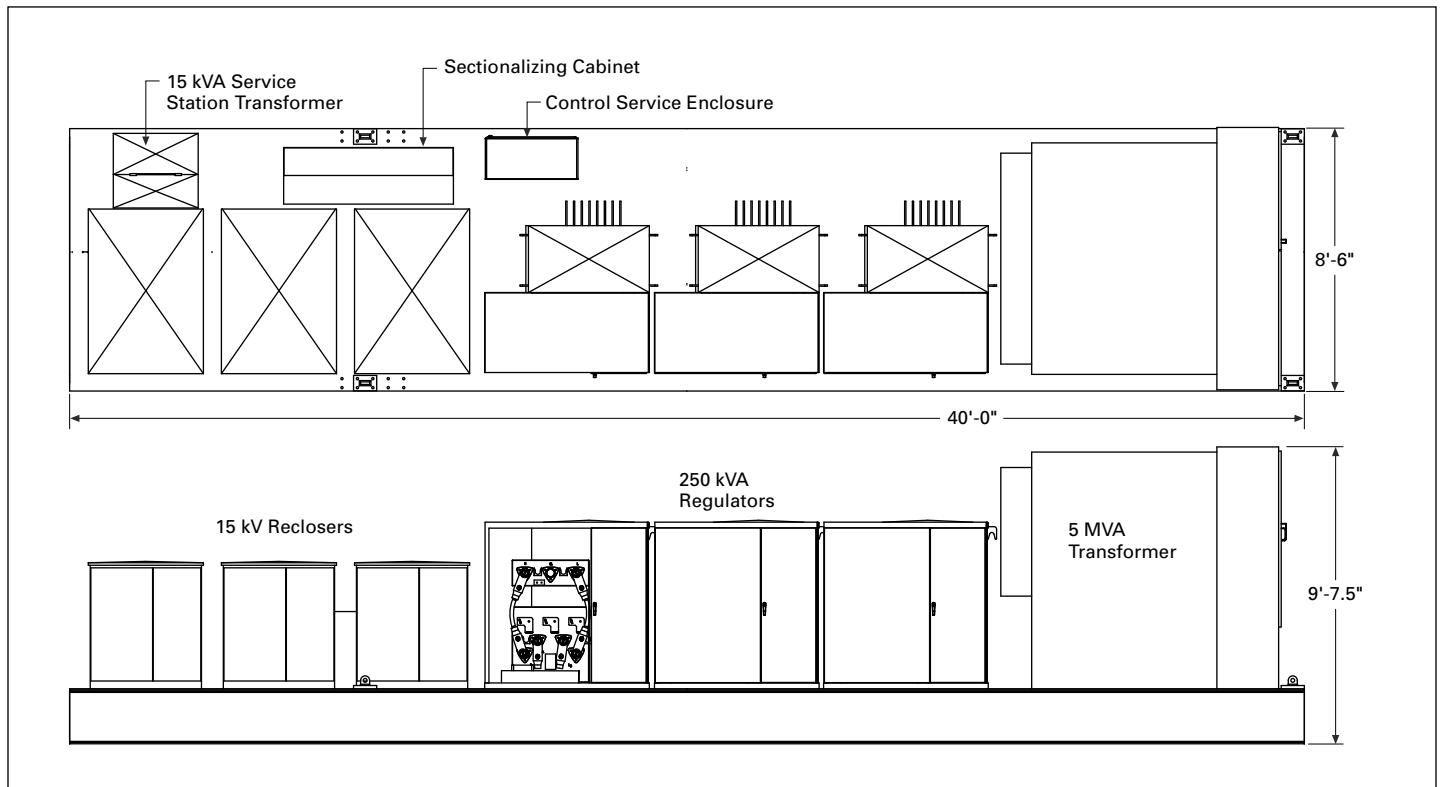

Figure 16. System Layout and Dimensions

Rural substation



Value proposition

Quick implementation with minimal disruption to the customer and the existing landscape.

A substation was needed to serve a remote industrial load. Because of the unique transformer design, it was acquired through a third party and installed on a separate structural steel platform along with a high-side recloser, which serves as a switch and protection device.

To achieve cooling requirements, fans were required on the transformer. (The external transformer cooling fans no longer make the assembly tamper-proof; therefore, fencing is required.) A second structural steel platform was used to pre-install and test three single-phase, pad-mounted voltage regulators, switchgear, a control center, and a station service transformer. The platforms were interconnected at the job site and the completed assembly, as an integrated whole, did not affect the integrity of this finished product.

Surface grading to level the area would have been required for a concrete foundation. Instead of the concrete foundation, steel pillars were installed at weight-bearing points under the entire MITS assembly to elevate the structure from ground level.

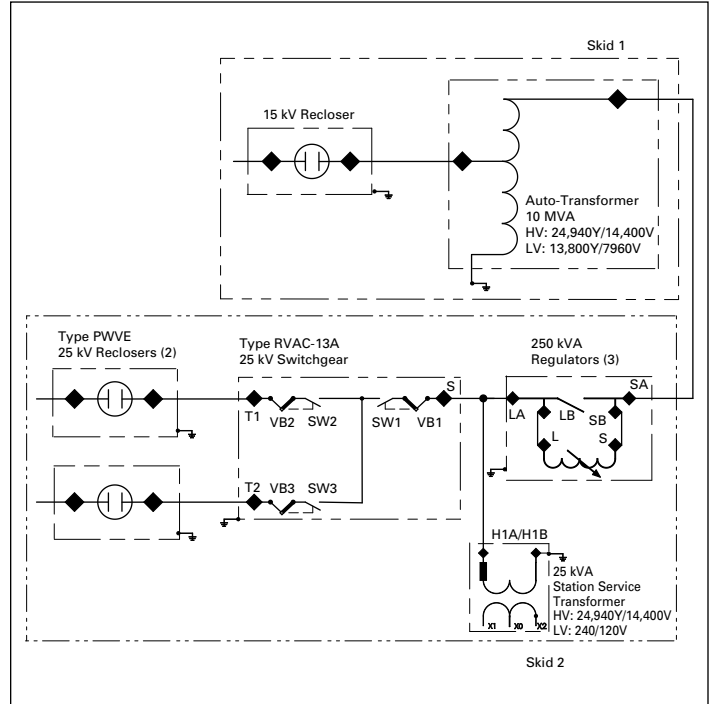

Figure 17. System Schematic

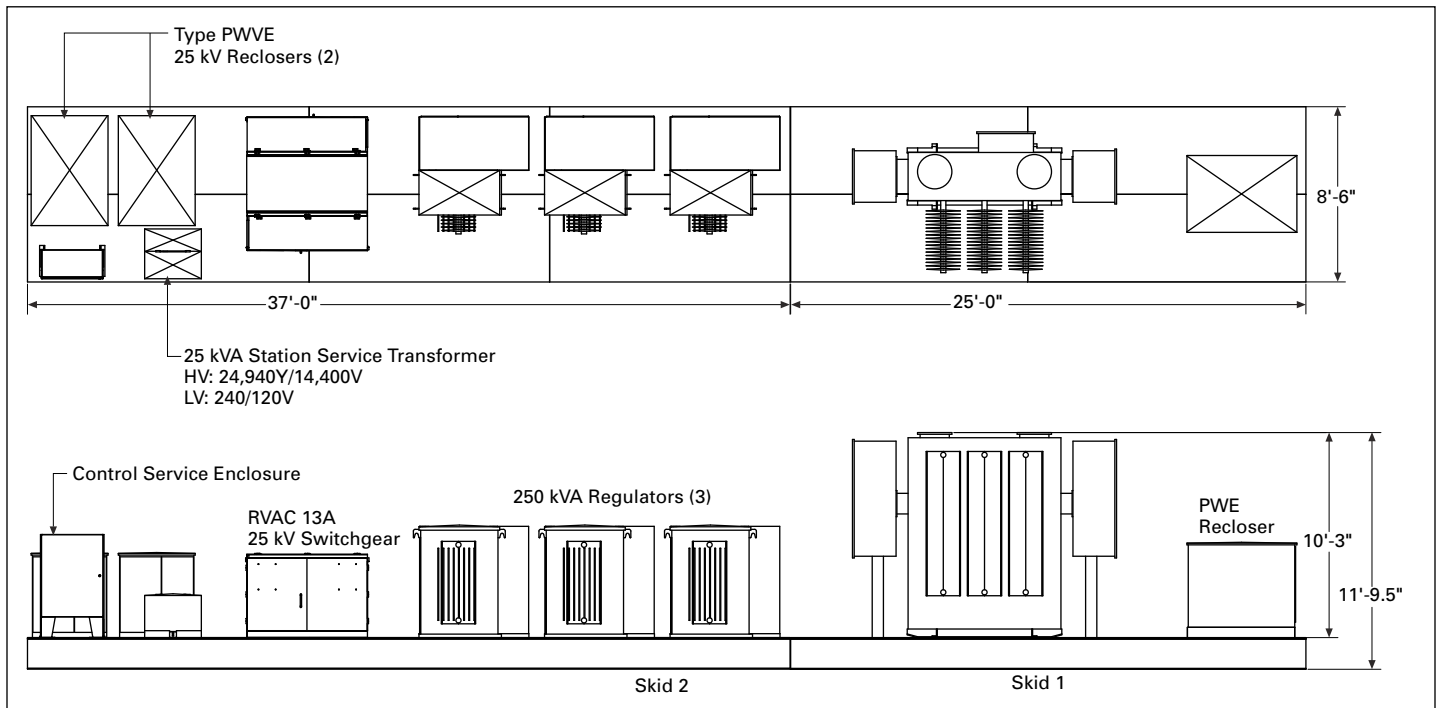

Figure 18. System Layout and Dimensions

Eaton
1000 Eaton Boulevard
Cleveland, OH 44122
United States
Eaton.com

© 2014 Eaton
All Rights Reserved
Printed in USA
Publication No. TD027002EN / Z15034
March 2014