

MA-VR⁺ VR-Series⁺ Replacement Circuit Breaker

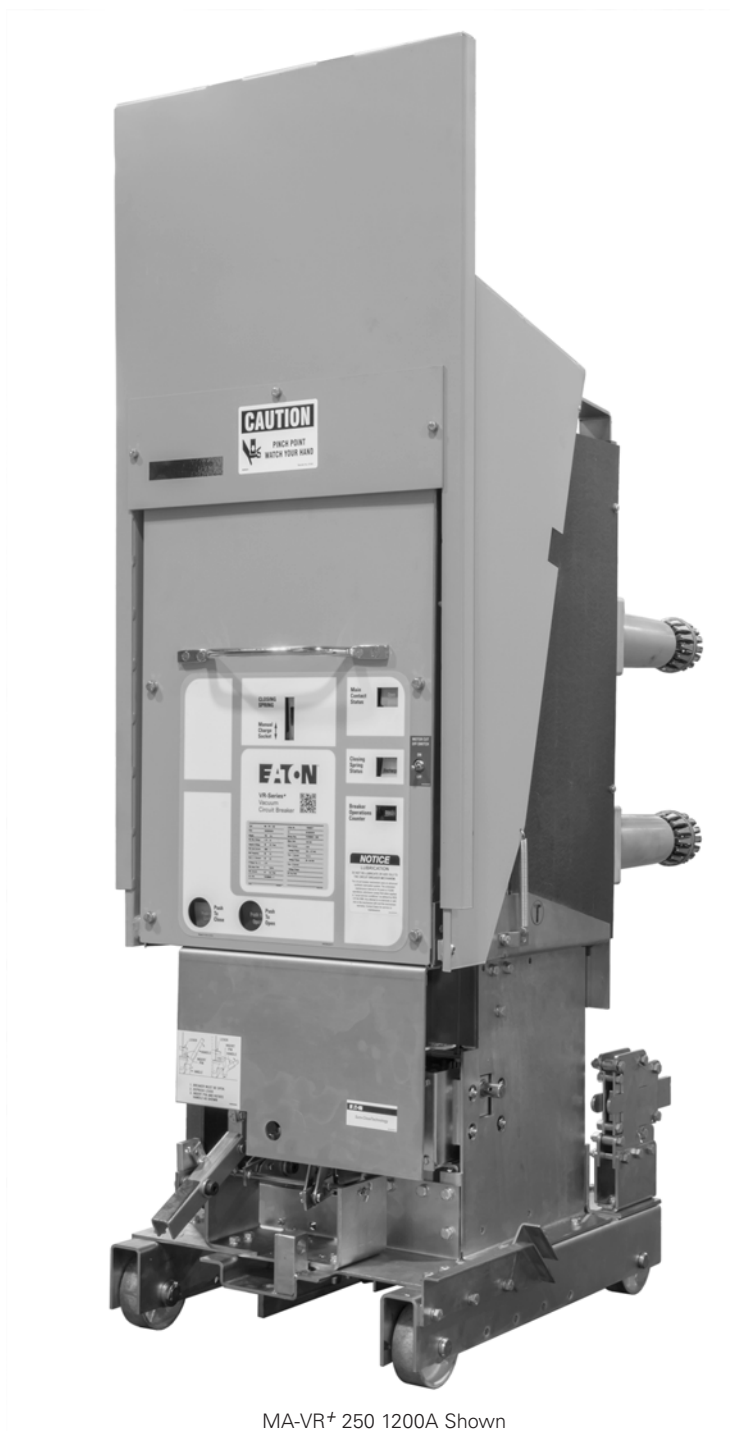

MA-VR⁺ 250 1200A Shown

DISCLAIMER OF WARRANTIES AND LIMITATION OF LIABILITY

The information, recommendations, descriptions and safety notations in this document are based on Eaton's experience and judgment and may not cover all contingencies. If further information is required, an Eaton sales office should be consulted. Sale of the product shown in this literature is subject to the terms and conditions outlined in appropriate Eaton selling policies or other contractual agreement between Eaton and the purchaser.

THERE ARE NO UNDERSTANDINGS, AGREEMENTS, WARRANTIES, EXPRESSED OR IMPLIED, INCLUDING WARRANTIES OF FITNESS FOR A PARTICULAR PURPOSE OR MERCHANTABILITY, OTHER THAN THOSE SPECIFICALLY SET OUT IN ANY EXISTING CONTRACT BETWEEN THE PARTIES. ANY SUCH CONTRACT STATES THE ENTIRE OBLIGATION OF EATON. THE CONTENTS OF THIS DOCUMENT SHALL NOT BECOME PART OF OR MODIFY ANY CONTRACT BETWEEN THE PARTIES.

In no event will Eaton be responsible to the purchaser or user in contract, in tort (including negligence), strict liability or other-wise for any special, indirect, incidental or consequential damage or loss whatsoever, including but not limited to damage or loss of use of equipment, plant or power system, cost of capital, loss of power, additional expenses in the use of existing power facilities, or claims against the purchaser or user by its customers resulting from the use of the information, recommendations and descriptions contained herein. The information contained in this manual is subject to change without notice.

DANGER

IMPROPERLY INSTALLING OR MAINTAINING THESE PRODUCTS MAY CAUSE THE EQUIPMENT TO FAIL, RESULTING IN DEATH, SEVERE PERSONAL INJURY, EQUIPMENT DAMAGE AND/OR IMPROPER OPERATION.

READ AND UNDERSTAND THESE INSTRUCTIONS BEFORE ATTEMPTING ANY UNPACKING, ASSEMBLY, OPERATION OR MAINTENANCE OF THE CIRCUIT BREAKERS.

INSTALLATION OR MAINTENANCE SHOULD BE ATTEMPTED ONLY BY QUALIFIED PERSONNEL. THIS INSTRUCTION BOOKLET SHOULD NOT BE CONSIDERED ALL INCLUSIVE REGARDING INSTALLATION OR MAINTENANCE PROCEDURES. IF FURTHER INFORMATION IS REQUIRED, YOU SHOULD CONSULT EATON'S ELECTRICAL SERVICES & SYSTEMS.

THE CIRCUIT BREAKERS DESCRIBED IN THIS BOOK ARE DESIGNED AND TESTED TO OPERATE WITHIN THEIR NAMEPLATE RATINGS. OPERATION OUTSIDE OF THESE RATINGS MAY CAUSE THE EQUIPMENT TO FAIL, RESULTING IN DEATH, SEVERE PERSONAL INJURY, EQUIPMENT DAMAGE AND/OR IMPROPER OPERATION.

ALL SAFETY CODES, SAFETY STANDARDS AND/OR REGULATIONS AS THEY MAY BE APPLIED TO THIS TYPE OF EQUIPMENT MUST BE STRICTLY ADHERED TO.

THESE VACUUM REPLACEMENT CIRCUIT BREAKERS ARE DESIGNED TO BE INSTALLED PURSUANT TO THE AMERICAN NATIONAL STANDARDS INSTITUTE (ANSI). SERIOUS INJURY, INCLUDING DEATH, SEVERE PERSONAL INJURY, EQUIPMENT DAMAGE AND/OR IMPROPER OPERATION.

This product was manufactured by Eaton at the Power Breaker Center (PBC): 310 Maxwell Avenue, Greenwood, SC 29646.

All possible contingencies which may arise during installation, operation or maintenance, and all details and variations of this equipment do not purport to be covered by these instructions. If further information is desired by purchaser regarding his particular installation, operation or maintenance of particular equipment, contact an Eaton representative.

Table of Contents

SECTION 1: INTRODUCTION	4	SECTION 5: INSPECTION & INSTALLATION	20
1.1 VISUAL INSTRUCTION BOOKLET ESSENTIALS	4	5.1 EXAMINATION FOR DAMAGE	20
1.2 QUICK RESPONSE CODE	4	5.1.1 NAMEPLATE VERIFICATION	20
1.3 AVAILABLE MA-VR+ CIRCUIT BREAKERS	4	5.2 CELL CODE / REJECTION PLATE INSTALLATION	20
SECTION 2: SAFE PRACTICES	7	5.3 SURE CLOSE MECHANISM ADJUSTMENT	20
SECTION 3: RECEIVING, HANDLING, AND STORAGE	8	5.4 PRE-INSTALLATION CELL CHECK	22
3.1 RECEIVING	8	5.4.1 SELF-ADJUSTING ANTI-ROTATION SYSTEM ADJUSTMENT (For all MA-VR+ Designs)	22
3.2 HANDLING	9	5.5 OPTIONAL SECONDARY CONNECTION BLOCK EXTENSION CABLE	23
3.3 STORAGE	9	5.6 OPERATIONAL POSITIONS	23
3.4 APPROXIMATE WEIGHT BY TYPE	9	5.7 INTERNAL ROTARY RACKING	23
SECTION 4: DESCRIPTION AND OPERATION	12	5.7.1 INSERTION PROCEDURE	23
4.1 VACUUM INTERRUPTER	12	5.7.2 REMOVAL PROCEDURE	24
4.1.1 VACUUM INTERRUPTER ASSEMBLY	12	SECTION 6: INSPECTION & MAINTENANCE	25
4.1.2 CONTACT EROSION INDICATOR	12	6.1 INSPECTION FREQUENCY	25
4.1.3 CONTACT WIPE AND STROKE	13	6.2 INSPECTION AND MAINTENANCE PROCEDURES	25
4.2 LINE AND LOAD CONDUCTOR ASSEMBLIES	13	6.3 VACUUM INTERRUPTER INTEGRITY TEST	26
4.3 STORED ENERGY MECHANISM	13	6.4 CONTACT EROSION AND WIPE	26
4.3.1 CLOSING SPRING CHARGING	13	6.5 INSULATION	27
4.3.2 CLOSING OPERATION	13	6.6 INSULATION INTEGRITY CHECK	27
4.3.3 TRIPPING OPERATION	14	6.7 PRIMARY CIRCUIT RESISTANCE CHECK	27
4.3.4 TRIP-FREE OPERATION	14	6.8 VR-SERIES+ CIRCUIT BREAKER ELEMENT MECHANISM CHECK	27
4.4 CONTROL SCHEMES	14	6.8.1 CLOSURE™ TEST	27
4.4.1 TIMING	14	6.9 MAINTENANCE RECOMMENDATION	31
4.6 SECONDARY CONNECTION BLOCK	14	SECTION 7: REPLACEMENT PARTS	33
4.7 INTERLOCKS	14	7.1 GENERAL	33
4.7.1 ANTI-CLOSE INTERLOCK	16	7.2 ORDERING INSTRUCTIONS	33
4.7.2 RACKING SYSTEM TRIP AND SPRING RELEASE INTERLOCKS	16	APPENDIX A: LEVERING HANDLE RACKING	34
4.7.3 SHUTTER OPERATING MECHANISM	16	A.1 LEVERING HANDLE RACKING SYSTEM	34
4.8 MOC (Mechanically Operated Contacts) OPERATOR	16	A.1.1 INSERTION PROCEDURE	34
4.9 TOC (Truck Operated Contacts) OPERATOR	16	A.1.2 REMOVAL PROCEDURE	35
4.10 RACKING MECHANISM	16	A.2 RACKING SYSTEM TRIP AND SPRING RELEASE INTERLOCKS	35
4.10.1 INTERNAL ROTARY RACKING	16	A.2.1 LEVERING HANDLE RACKING	35
4.10.2 LEVERING HANDLE RACKING	16	A.2.2 MA-VR PRIMARY STAB TOLERANCE	35
4.11 GROUNDING CONTACT	16	APPENDIX B: OPTIONAL SECONDARY CONNECTION BLOCK EXTENSION CABLE	36
4.12 MISCELLANEOUS ITEMS	16	B.1 INSTALLATION AND REMOVAL	36
4.12.1 OPERATIONS COUNTER	16		

SECTION 1: INTRODUCTION

This instruction booklet provides information on receiving and handling, storage, installation, operation and maintenance of the MA VR-Series+ vacuum replacement circuit breaker. The Vacuum Replacement circuit breakers (also referred to as VR-Series+) are designed to be used in existing Allis-Chalmers type MA metal-clad switchgear. The VR-Series+ circuit breakers provide superior electrical and mechanical performance as compared to the design ratings of the original circuit breaker. VR-Series+ circuit breakers provide reliable control, protection and performance, with ease of handling and maintenance. Like ratings of the VR-Series+ circuit breakers are interchangeable with each other.

The VR-Series+ circuit breaker element offers:

- **10-year or 10,000 operation scheduled maintenance intervals.** When applied in “usual service conditions” as defined by IEEE C37.04-1999, the VR-Series+ circuit breaker element requires maintenance only once every ten years or ten thousand operations, whichever comes first.
Note: See Inspection & Maintenance section in this booklet for details.
- **Increased mechanical endurance.** Circuit breakers in repetitive duty applications offer 50% more operations over conventional vacuum circuit breaker elements before parts replacement may be needed.
- **Increased short circuit capability.** The VR-Series+ circuit breaker short circuit capability can be increased to 41 kA, provided a bus bracing study is performed and the switchgear is adequately braced to meet the requirements per IEEE C37.59.

Use this instruction bulletin in conjunction with the technical information provided with the original equipment order which includes electrical control schematic and wiring diagrams, outline diagrams, installations plans, and procedures for installation and maintenance of accessory items.

Satisfactory performance is dependent on proper application, correct installation, and adequate maintenance. It is very important that this installation and maintenance instruction booklet be read and followed closely to achieve optimum performance and a long useful circuit breaker life in its application.

1.1 VISUAL INSTRUCTION BOOKLET ESSENTIALS

Eaton provides additional documentation designed to enhance the technical information provided in this instruction booklet for the VR-Series+ circuit breakers. The Visual Instruction Booklet Essentials (VIBE) is a digital supplemental booklet featuring user interactive content and informative videos intended to assist with the maintenance of the VR-Series+ circuit breaker. The VIBE document is available for immediate download at www.eaton.com/VR-Series.

Figure 1.1. Quick Response Code

VR-Series+ QR Code



1.2 QUICK RESPONSE CODE

VR-Series+ circuit breakers have a quick response code (QR Code) on the escutcheon of the circuit breaker front cover. This QR Code is a matrix barcode that provides direct access to download VR-Series+ specific documentation, such as product instruction booklets and the VIBE documentation. See Figure 1.1 for the featured VR-Series+ QR Code.

Note: A smart phone with an adequate QR Code Scanner application must be used. Downloading content may incur data charges from the mobile service provider.

⚠ WARNING

SATISFACTORY PERFORMANCE OF THESE CIRCUIT BREAKERS IS CONTINGENT UPON PROPER APPLICATION, CORRECT INSTALLATION AND ADEQUATE MAINTENANCE. THIS INSTRUCTION BOOKLET MUST BE CAREFULLY READ AND FOLLOWED IN ORDER TO OBTAIN OPTIMUM PERFORMANCE FOR LONG USEFUL LIFE OF THE CIRCUIT BREAKERS. IT IS FURTHER RECOMMENDED THAT THE INSTALLATION BE PERFORMED BY AN EATON TRAINED ENGINEER OR TECHNICIAN.

VR-SERIES+ CIRCUIT BREAKERS ARE PROTECTIVE DEVICES, AS SUCH, THEY ARE MAXIMUM RATED DEVICES. THEREFORE, THEY SHOULD NOT UNDER ANY CIRCUMSTANCE BE APPLIED OUTSIDE THEIR NAMEPLATE RATINGS.

ALL POSSIBLE CONTINGENCIES WHICH MIGHT ARISE DURING INSTALLATION, OPERATION, OR MAINTENANCE, AND ALL DETAILS AND VARIATIONS OF THIS EQUIPMENT ARE NOT COVERED BY THESE INSTRUCTIONS. IF FURTHER INFORMATION IS DESIRED BY THE PURCHASER REGARDING A PARTICULAR INSTALLATION, OPERATION, OR MAINTENANCE OF THIS EQUIPMENT, THE LOCAL EATON REPRESENTATIVE SHOULD BE CONTACTED.

1.3 AVAILABLE MA-VR+ CIRCUIT BREAKERS

Refer to Table 1.

Table 1. MA-VR+ Availability and Interchangeability

Existing MA Circuit Breaker Type	MA-VR+ Circuit Breaker Type ①	Maximum Voltage	Nominal 3-Phase MVA Class	Existing Circuit Breaker Rated Continuous Current at 60 Hz	Rated Voltage Factor	Rated Withstand ANSI Test Voltage		Rated Short-Circuit	Maximum Sym. Interrupting Capability	Closing and Latching / Momentary Capabilities
						Low Freq. kV RMS	Impulse kV Peak			
		kV	MVA	Amps	K	I	KA RMS	KI	KA RMS	KA RMS / Peak
MA250	MA-VR+250	4.76	250	1200 / 2000	1.24	19	60	29	36	58 / 97
MA250	MA-VR+41 ②③	4.76	250	1200 / 2000	1.00	19	60	41	41	78 / 132

- ① All circuit breakers have a 3 second short-time and 3-cycle interrupting ratings.
- ② Non-standard rating.
- ③ Requires bus bracing study and additional switchgear bracing.

MA-VR+
VR-Series+ Replacement Circuit Breaker

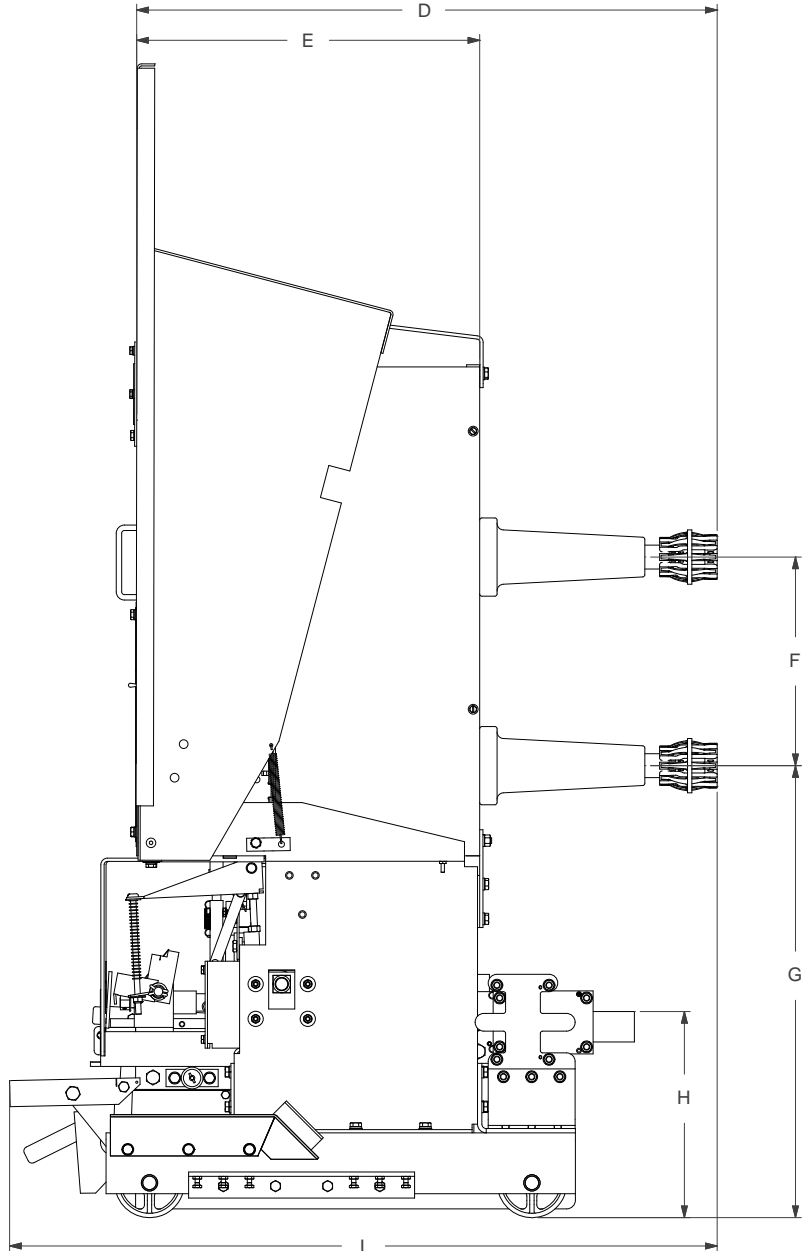
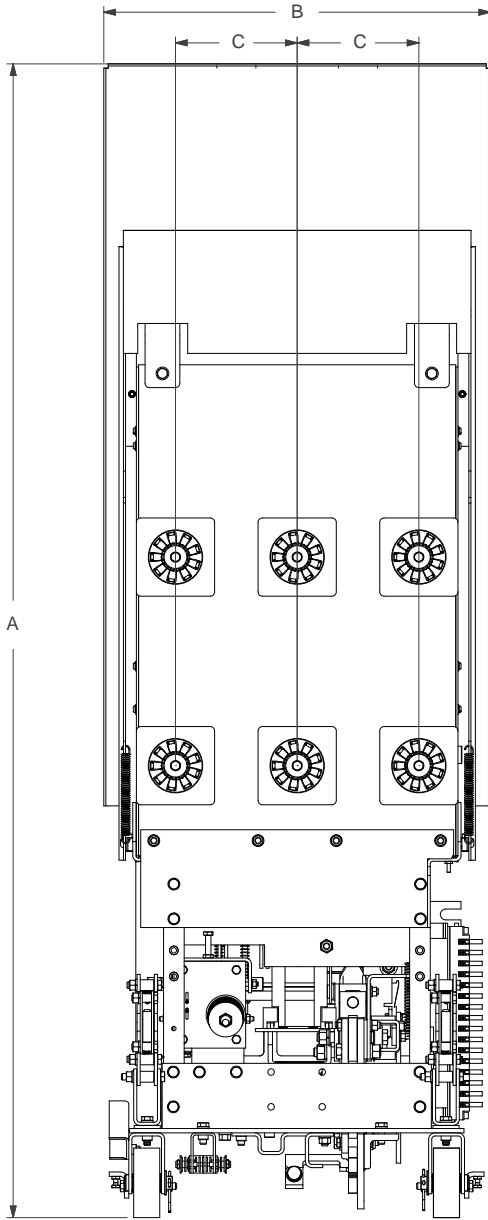

Table 2. MA-VR+ Dimensions

Circuit Breaker Type	Existing Circuit Breaker Rated Continuous Current at 60 Hz (Amps)	A	B	C	D	E	F	G	H	I
MA-VR+	1200 / 2000	66.37	22.25	7.00	33.39	19.73	12.00	26.00	11.85	40.70

SECTION 2: SAFE PRACTICES

VR-Series+ circuit breakers are equipped with high speed, high energy operating mechanisms. They are designed with several built-in interlocks and safety features to provide safe and proper operating sequences.

⚠ DANGER

TO PROTECT THE PERSONNEL ASSOCIATED WITH INSTALLATION, OPERATION, AND MAINTENANCE OF THESE CIRCUIT BREAKERS, THE FOLLOWING PRACTICES MUST BE FOLLOWED:

- Only qualified persons, as defined in the National Electrical Safety Code, who are familiar with the installation and maintenance of medium voltage circuits and equipment, should be permitted to work on these circuit breakers.
- Read these instructions carefully before attempting any installation, operation or maintenance of these circuit breakers.
- Always remove the circuit breaker from the enclosure before performing any maintenance. Failure to do so could result in electrical shock leading equipment failure, resulting in death, severe personal injury, equipment damage and/or improper operation.
- Do not work on a circuit breaker with the secondary test coupler engaged. Failure to disconnect the test coupler could result in an electrical shock leading to death, severe personal injury, equipment damage and/or improper operation.
- Do not work on a closed circuit breaker or a circuit breaker with closing springs charged. The closing spring should be discharged and the main contacts open before working on the circuit breaker. Failure to do so could result in cutting or crushing injuries.
- Do not use a circuit breaker by itself as the sole means of isolating a high voltage circuit. Remove the circuit breaker to the 'Disconnect' position and follow all lockout and tagging rules of the National Electrical Code and any and all applicable codes, regulations and work rules.
- Do not leave the circuit breaker in an intermediate position in the circuit breaker compartment. Always have the circuit breaker either in the 'Test' or 'Connect' position. Failure to do so could result in a flash over causing the equipment to fail, resulting in death, severe personal injury, equipment damage and/or improper operation.
- Always remove the maintenance tool from the circuit breaker after charging the closing springs.
- Circuit breakers are equipped with safety interlocks. Do not defeat them. This may result in equipment failure, resulting in death, severe personal injury, equipment damage and/or improper operation.

MA-VR+ VR-Series+ Replacement Circuit Breaker

SECTION 3: RECEIVING, HANDLING, AND STORAGE

VR-Series+ circuit breakers are subjected to complete factory production tests and inspection before being packed. They are shipped in packages designed to provide maximum protection to the equipment during shipment and storage and at the same time to provide convenient handling. Accessories such as the maintenance tool, code plate, (if applicable) etc. are shipped with the circuit breaker.

3.1 RECEIVING

Until the circuit breaker is ready to be delivered to the switchgear site for installation, DO NOT remove it from the shipping crate. If the circuit breaker is to be placed in storage, maximum protection can be obtained by keeping it in its crate.

Upon receipt of the equipment, inspect the crates for any signs of damage or rough handling. Open the crates carefully to avoid any damage to the contents. Use a nail puller rather than a crow bar when required.

When opening the crates, be careful that any loose items or hardware are not discarded with the packing material. Check the contents of each package against the packing list.

Examine the circuit breaker for any signs of shipping damage such as broken, missing or loose hardware, damaged or deformed insulation and other components. If damaged or loss is detected, file claims immediately with the carrier and notify an Eaton representative.

Tools and Accessories

Maintenance Tool (Style# 94C9506G01): This tool is used to manually charge the closing springs. One maintenance tool is provided with each vacuum replacement circuit breaker.

Rotary Racking Handle (Style# 94A3149G11): Rotary racking is possible utilizing a speed-handle, suitable extensions and a standard 3/4" socket. One rotary racking handle is provided per order. If necessary, additional racking handles may be purchased directly from Eaton. This handle is used with the rotary racking system for insertion and removal.

Levering Handle: The original MA levering handle is used to assist in moving the circuit breaker into and out of the cell. However, it cannot be used with the rotary racking system. Its use is illustrated in Appendix A.

Secondary Connection Block Extension Cable (Original): The extension cable can be used to connect the circuit breaker to a "test cabinet" or to the switchgear cell's secondary receptacle block so that the circuit breaker can be electrically operated while not installed in the switchgear cell. This extension cable is the same one provided with the Allis-Chalmers circuit breaker and is therefore not included as part of the vacuum replacement circuit breaker.

Secondary Connection Block Extension Cable (Replacement): In the event the original secondary connection block extension cable is no longer available a new designed replacement is available from Eaton (Style #94A3147G30) (Figure 3.1.c). Refer to Appendix B for information on its installation and use.

Lifting Strap (Style# 94B1194G01): Optional item recommended for lifting the MA-VR+ circuit breaker.

Turning Dolly (Style# 94A9502G02): Optional item used to help maneuver circuit breaker when out of the circuit breaker compartment.

Figure 3.1.a. Typical Tools and Accessories



Figure 3.1.b. Rotary Racking Handle



Figure 3.1.c. Secondary Connection Block Extension Cable Replacement (Optional)



3.2 HANDLING

⚠ WARNING

DO NOT USE ANY LIFTING DEVICE AS A PLATFORM FOR PERFORMING MAINTENANCE, REPAIR OR ADJUSTMENT OF THE CIRCUIT BREAKER OR FOR OPENING, CLOSING THE CONTACTS OR CHARGING THE SPRINGS. THE CIRCUIT BREAKER MAY SLIP OR FALL CAUSING SEVERE PERSONAL INJURY. ALWAYS PERFORM MAINTENANCE, REPAIR AND ADJUSTMENTS ON A WORKBENCH CAPABLE OF SUPPORTING THE CIRCUIT BREAKER TYPE.

VR-Series+ circuit breaker shipping containers are designed to be handled either by use of an overhead lifting device or by a fork lift truck. If containers must be skidded for any distance, it is preferable to use roller conveyors or individual pipe rollers.

Once a circuit breaker has been inspected for shipping damage, it is best to return it to its original shipping crate until it is ready to be installed in the metal-clad switchgear.

When the circuit breaker is ready for installation, a lifting harness in conjunction with an overhead lift or portable floor lift can be used to move the circuit breaker. If the circuit breaker is to be lifted, position the lifting device over the circuit breaker and insert the lifting harness hooks into the circuit breaker side lifting points and secure (lifting straps should have at least a 1000lbs lift capacity). Be sure the hooks are firmly attached before lifting the circuit breaker. Stand a safe distance away from the circuit breaker while lifting and moving.

Figure 3.2. Lifting MA-VR+



3.3 STORAGE

If the circuit breaker is to be placed in storage, maximum protection can be obtained by keeping it in the original shipping crate. Confirm that the circuit breaker is free from shipping damage and is in satisfactory operating condition before placing it in to storage.

The circuit breaker is shipped with its contacts open and closing springs discharged. The indicators on the front cover should confirm this. Insert the end of the maintenance tool into the manual charge socket opening and charge the closing springs by moving the handle up and down the full range of motion. When charging is complete the ratchet will no longer advance and the spring charged / discharged indicator displays 'Charged'. (Figure Set 3.3). Remove the maintenance tool. Push the "manual close" operator. The circuit breaker will close as shown by the circuit breaker contacts 'Closed' indicator. Push the "manual trip" operator. The circuit breaker will trip as shown by the circuit breaker contacts 'Open' indicator. After completing this initial check, leave the closing springs 'Discharged' and circuit breaker contacts 'Open'.

Outdoor storage is NOT recommended. If unavoidable, the outdoor location must be well drained and a temporary shelter from sun, rain, snow, corrosive fumes, dust, dirt, falling objects, excessive moisture, etc. must be provided. Containers should be arranged to permit free circulation of air on all sides and temporary heaters should be used to minimize condensation. Moisture can cause rusting of metal parts and deterioration of high voltage insulation. A heat level of approximately 400 watts for each 100 cubic feet of volume is recommended with the heaters distributed uniformly throughout the structure near the floor.

Indoor storage should be in a building with sufficient heat and circulation to prevent condensation. If the building is not heated, the same general rule for heat as for outdoor storage should be applied.

3.4 APPROXIMATE WEIGHT BY TYPE

Table 3. Approximate Weight by Type

Type	Amperes	LBs
MA-VR+	1200	670*
	2000	750*

Note: * = An additional 75lbs is added with the optional internal Rotary Racking system.

MA-VR+
VR-Series+ Replacement Circuit Breaker

Figure 3.3. Front External View of MA-VR+ (Internal Rotary Racking Design)

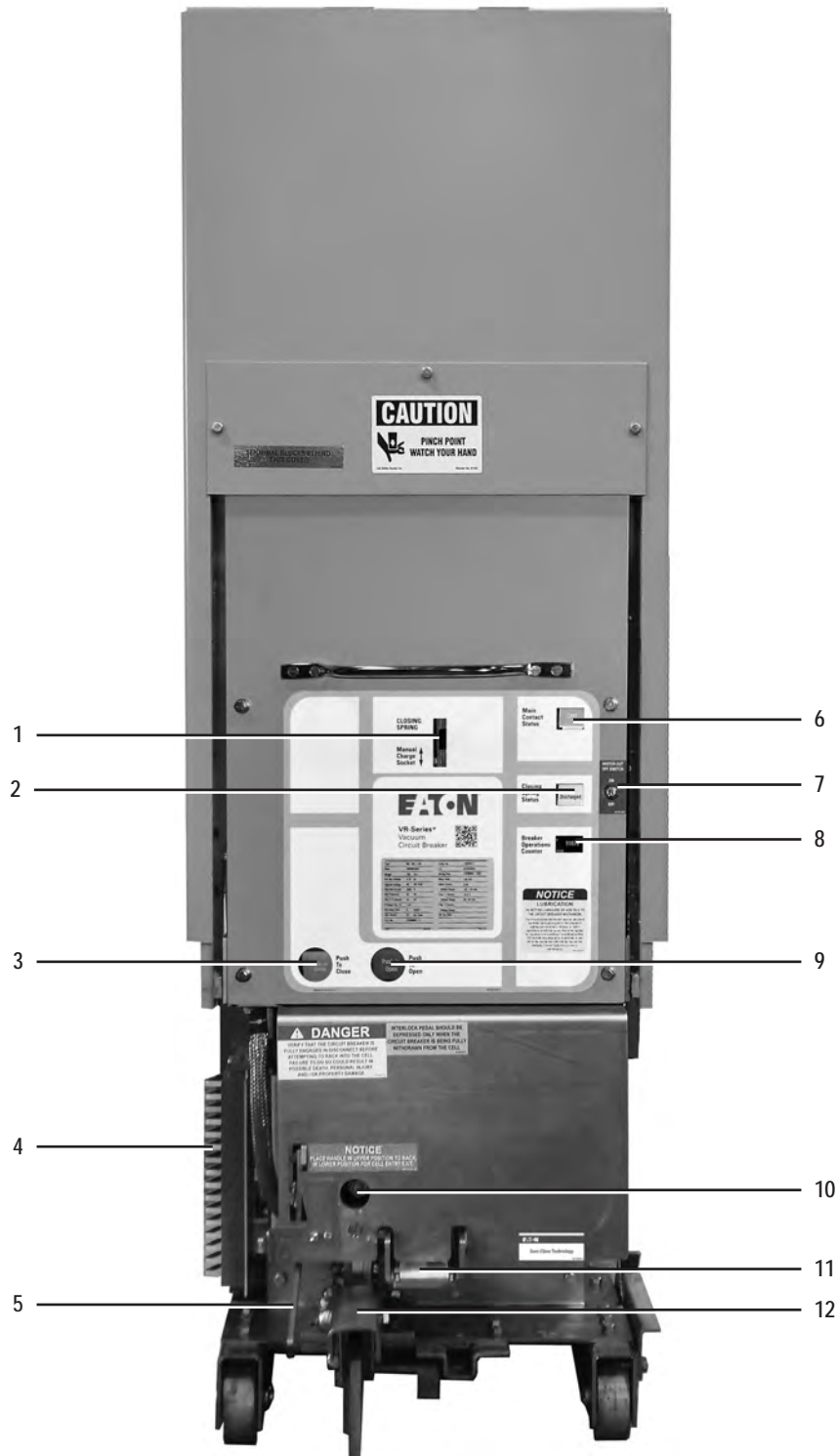

Front External View

1	Manual Charging Socket	5	Racking Access Handle	9	Push To Open Button
2	Spring Charged / Discharged Indicator	6	Circuit Breaker Contacts Indicator	10	Rotary Racking Access
3	Push To Close Button	7	Manual Motor Cut-Off Switch	11	Circuit Breaker Position Indicator
4	Secondary Disconnect	8	Operations Counter	12	Interlock Pedal

Figure 3.4. Rear External View of MA-VR+

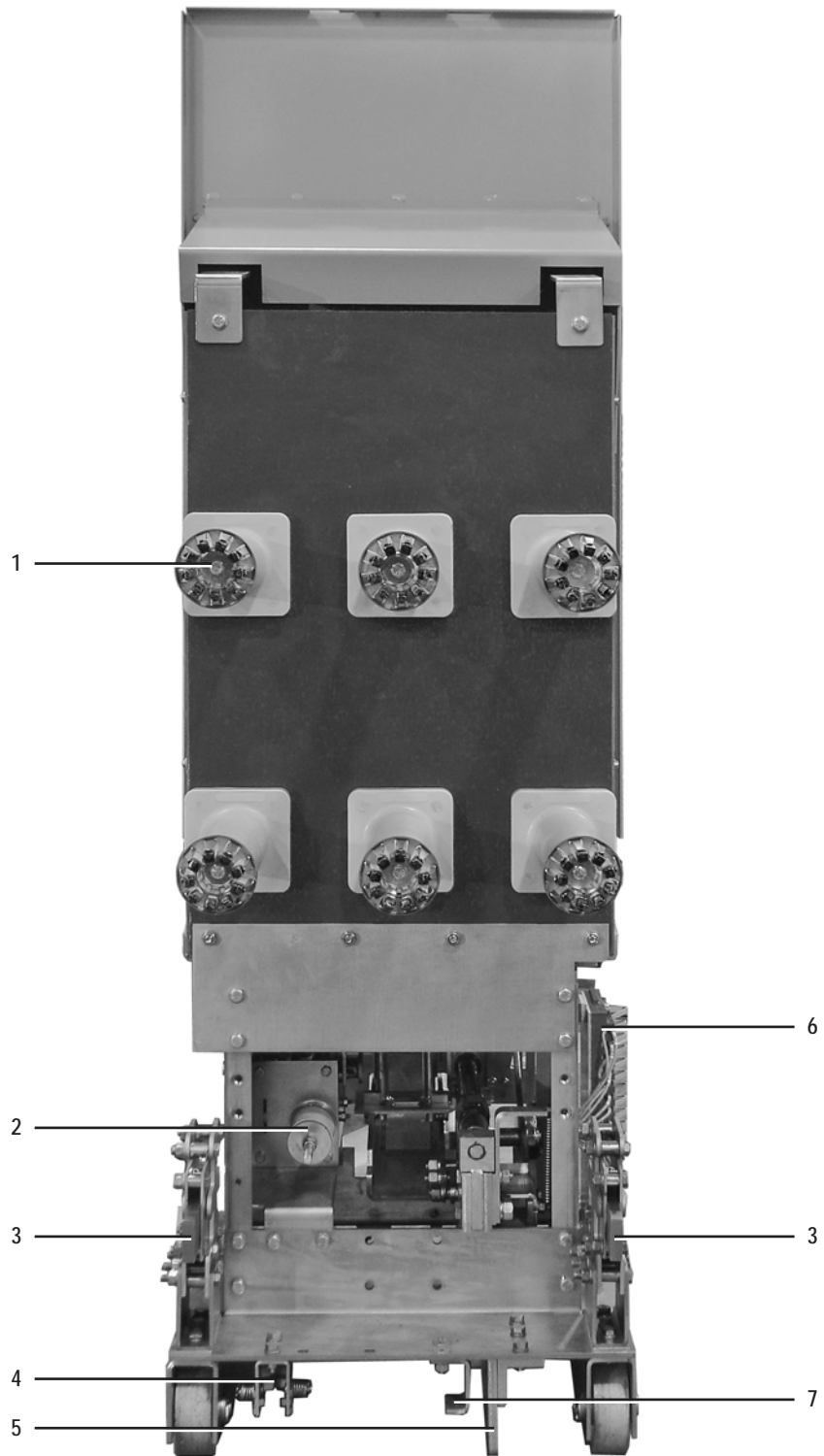

Rear External View

1	Primary Disconnect	4	Ground Contact	7	Code Plate
2	SURE CLOSE Spring	5	Guide Bar		
3	Self-Adjusting Anti-Rotation Device	6	Secondary Disconnect		

SECTION 4: DESCRIPTION AND OPERATION

VR-Series+ vacuum replacement circuit breakers are designed to be used with existing installations of equivalent air-magnetic metal-clad switchgear circuit breakers. The front mounted spring type stored energy mechanism facilitates inspection and provides improved access to components for servicing. The long life characteristics of the vacuum interrupters and proven high reliability of spring-type stored energy mechanisms assure long, trouble-free service with minimum maintenance.

4.1 VACUUM INTERRUPTER

Vacuum interrupters offer the advantages of enclosed arc interruption, small size and weight, longer life, reduced maintenance, minimal mechanical shock, and elimination of contact degradation caused by environmental contamination.

In the closed position, current flows through the interrupter moving and fixed stems and the faces of the main contacts. As the contacts part, an arc is drawn between the contact surfaces. The arc is rapidly moved away from the main contacts to the slotted contact surfaces by self-induced magnetic effects. This minimizes contact erosion and hot spots on the contact surfaces. The arc flows in an ionized metal vapor and if the vapor leaves the contact area, it would condense into the metal shield which surrounds the contacts.

At current zero, the arc extinguishes and vapor production ceases. Very rapid dispersion, cooling, recombination, and deionization of the metal vapor plasma and fast condensation of metal vapor causes the vacuum to be quickly restored and prevents the transient recovery voltage from causing a restrike across the gap of the open contacts.

4.1.1 VACUUM INTERRUPTER ASSEMBLY

Each vacuum interrupter assembly (also referred to as pole unit) is assembled at the factory as a unit to assure correct dimensional relationships between working components. Three interrupter assemblies are used per circuit breaker. Each vacuum interrupter assembly consists of a molded insulator frame and includes the vacuum interrupter, its lead assembly, bell crank, operating rod, stand-off insulator, and contact load spring. The vacuum interrupter is mounted vertically with the stationary vacuum interrupter stem upward and the moving interrupter stem downward. The pole units are fastened to the circuit breaker's stored energy mechanism frame. Silver-plated copper laminated shunts transfer current from the moving interrupter stem to the upper primary bushings via a Holm-free, non-sliding conical current transfer. A silver-plated copper casting is attached to the stationary stem, completing the primary circuit to the lower disconnect assemblies. The operating rod, loading spring, and bell crank transfer the mechanical motion from the circuit breaker's stored energy mechanism to the moving stem of the vacuum interrupter.

4.1.2 CONTACT EROSION INDICATOR

The purpose of the contact erosion indicator is to monitor the erosion of the vacuum interrupter contacts, which is very minimal over time with Eaton vacuum interrupters utilizing copper-chrome contact material. The VR-Series+ vacuum interrupter assembly incorporates both the original vacuum interrupter erosion indicator and the contact-spring wipe into one all-encompassing indicator. The adequacy of the remaining contact erosion and wipe can easily be determined by observing the moving end of the vacuum interrupter assembly on a closed circuit breaker. The procedure to determine the adequacy of the "T" cutout on the vacuum interrupter assembly is depicted in Figures 6.1 and 6.2. If the wipe is inadequate (no part of the "T" cutout is visible) then the vacuum interrupter assembly must be replaced. Field adjustment is not possible.

Figure 4.1. Vacuum Interrupter Assembly



Figure 4.2. Vacuum Interrupter Assembly (All Three Pole Units)



⚠ DANGER

FAILURE TO REPLACE THE VACUUM INTERRUPTER ASSEMBLY WHEN INDICATED BY THE CONTACT EROSION INDICATOR COULD CAUSE THE CIRCUIT BREAKER TO FAIL, LEADING TO DEATH, SEVERE PERSONAL INJURY, EQUIPMENT DAMAGE AND/OR IMPROPER OPERATION.

4.1.3 CONTACT WIPE AND STROKE

The circuit breaker mechanism provides a fixed amount of motion to the operating rods connected to the moving stem of the vacuum interrupter. The first portion of the motion, the stroke, is used to close the vacuum interrupter contacts; the remainder of that motion, the wipe, is used to further compress the pre-loaded wipe spring. Contact stroke and wipe are related; contact wipe is the indication of the force holding the vacuum interrupter contacts closed as well as the energy available to hammer the contacts open with sufficient speed for interruption. Stroke is the gap between the stationary and moving contact of the vacuum interrupter when the circuit breaker is open. As the stroke increases due to contact erosion inside the vacuum interrupter, the wipe decreases. Although these changes are taking place as operations accumulate on the vacuum interrupter, field adjustment of the wipe or stroke are not necessary during the lifetime of the vacuum interrupter.

⚠ WARNING

THERE IS NO PROVISION FOR IN-SERVICE ADJUSTMENTS OF CONTACT WIPE AND STROKE. ALL SUCH ADJUSTMENTS ARE FACTORY SET AND SHOULD NOT BE ATTEMPTED IN THE FIELD.

4.2 LINE AND LOAD CONDUCTOR ASSEMBLIES

Multiple finger type primary disconnecting contacts at the ends of the conductors provide means for connecting and disconnecting the circuit breaker to the bus terminals in the circuit breaker compartment of the metal-clad switchgear.

4.3 STORED ENERGY MECHANISM

The spring-type stored energy operating mechanism is mounted on the circuit breaker frame and in the front of the circuit breaker. Manual closing and opening controls are at the front cover (Figure Set 3.3). They are accessible while the circuit breaker is in any of its basic installation positions. (See Section 5 in this manual)

The mechanism stores the closing energy by charging the closing springs. Spring charging is automatically accomplished when control power is applied to the circuit breaker secondary disconnect contact. When released, the stored energy closes the circuit breaker, charges the wipe and resets the opening springs. The mechanism may rest in any one of the four positions shown in Figure 4.8 as follows:

- a. Circuit Breaker open, closing springs discharged.
- b. Circuit Breaker open, closing springs charged.
- c. Circuit Breaker closed, closing springs discharged.
- d. Circuit Breaker closed, closing springs charged.

The mechanism is a mechanically “trip-free” design. Trip-free is defined in Section 4.3.4 (Trip-Free Operation).

In normal operation the closing spring is charged by the spring charging motor, and the circuit breaker is closed electrically by the switchgear control circuit signal to energize the spring release coil. Tripping is caused by energizing the trip coil through the control circuit.

For maintenance inspection purposes the closing springs can be charged manually by using the maintenance tool and the circuit breaker can be closed and tripped by pushing the “Push to Close” and “Push to Open” operators on the front cover.

⚠ DANGER

KEEP HANDS AND FINGERS AWAY FROM CIRCUIT BREAKER'S INTERNAL PARTS WHILE THE CIRCUIT BREAKER CONTACTS ARE CLOSED OR THE CLOSING SPRINGS ARE CHARGED. THE CIRCUIT BREAKER CONTACTS MAY OPEN OR THE CLOSING SPRINGS DISCHARGE CAUSING CRUSHING INJURY. DISCHARGE THE SPRINGS AND OPEN THE CIRCUIT BREAKER BEFORE PERFORMING ANY MAINTENANCE, INSPECTION OR REPAIR ON THE CIRCUIT BREAKER.

THE DESIGN OF THIS CIRCUIT BREAKER ALLOWS MECHANICAL CLOSING AND TRIPPING OF THE CIRCUIT BREAKER WHILE IT IS IN THE 'CONNECT' POSITION. HOWEVER, THE CIRCUIT BREAKER SHOULD BE CLOSED MECHANICALLY ONLY IF THERE IS POSITIVE VERIFICATION THAT LOAD SIDE CONDITIONS PERMIT. IT IS RECOMMENDED THAT CLOSING THE CIRCUIT BREAKER IN THE 'CONNECT' POSITION ALWAYS BE DONE WITH THE CUBICLE DOOR CLOSED. FAILURE TO FOLLOW THESE DIRECTIONS MAY CAUSE DEATH, SEVERE PERSONAL INJURY, EQUIPMENT DAMAGE AND/OR IMPROPER OPERATION.

ELECTRICAL TRIPPING CAN BE VERIFIED WHEN THE CIRCUIT BREAKER IS IN THE 'DISCONNECT / TEST' POSITION.

4.3.1 CLOSING SPRING CHARGING

Figure 4.7 shows schematic section views of the spring charging parts of the stored energy mechanism.

The major component of the mechanism is a cam shaft assembly which consists of a shaft to which are attached two closing spring cranks (one on each end), the closing cam, drive plate, and a free-wheeling ratchet wheel.

The ratchet wheel (6) is actuated by an oscillating ratchet lever (12) and drive pawl (10) driven by the motor eccentric cam. As the ratchet wheel rotates, it pushes the drive plates which in turn rotate the closing spring cranks and the closing cam on the cam shaft. The motor will continue to run until the limit switch “LS” contact disconnects the motor.

The closing spring cranks have spring ends connected to them, which are in turn coupled to the closing springs. As the cranks rotate, the closing springs get charged.

The closing springs are completely charged, when the spring cranks go over dead center and the closing stop roller (9) comes against the spring release latch (1). The closing springs are now held in the fully charged position.

The closing springs may also be charged manually as follows: Insert the end of the maintenance tool into the manual charge socket opening and charge the closing springs by moving the handle up and down the full range of motion. When charging is complete the ratchet will no longer advance and the spring charged / discharged indicator displays ‘Charged’. (Figure Set 3.3). Any further motion of the maintenance tool will not result into advance of charging.

4.3.2 CLOSING OPERATION

Figure 4.8 shows the positions of the closing cam and tripping linkage for four different operational states. In Figure 4.8.a the circuit breaker is open and the closing springs are not charged. In this state, the trip latch (8) is disengaged from the trip “D” shaft (9) (unlatched). After the closing springs become charged, the trip latch snaps into the fully reset or latched position (Figure 4.8.b)

When the spring release clapper (Figure 4.7, Item 13) moves into the face of the spring release coil (electrically or manually), the lower portion of the clapper pushes the spring release latch (1) downward. When the spring release latch moves, the cam shaft assembly is free to rotate. The force of the closing cam (Figure 4.8.b, Item 5), moving the main link (2), rotating the pole shaft (4) (which charges the opening spring). This moves the three operating rods (3), closes the main contacts and charges the contact loading springs (not shown). The operational state immediately after the main contacts close but before the spring charging motor recharges the closing springs is illustrated in Figure 4.8.c. Interference of the trip “D” shaft with the trip latch prevents the linkage from collapsing, and holds the circuit breaker closed.

MA-VR+ VR-Series+ Replacement Circuit Breaker

Figure 4.8.d shows the circuit breaker in the closed state after the closing springs have been recharged. The recharging of the spring rotates the closing cam one half turn. In this position the main link roller rides on the cylindrical portion of the cam, and the main link does not move out of position.

4.3.3 TRIPPING OPERATION

When the trip bar “D” shaft (Figure 4.8.b, Item 9) is turned by movement of the shunt trip clapper (11), the trip latch will slip past the straight cut portion of the trip bar shaft and will allow the banana link and main link roller to lower. The energy of the opening spring and contact loading springs is released to open the main contacts. The mechanism is in the state illustrated (Figure 4.8.b) after the circuit breaker is tripped open.

4.3.4 TRIP-FREE OPERATION

When the manual trip button is held depressed, any attempt to close the circuit breaker results in the closing springs discharging without movement of the pole shaft or vacuum interrupter stem.

4.4 CONTROL SCHEMES

There are two basic control schemes for the VR-Series+ circuit breaker elements, one for dc control and one for ac control voltages (Figure 4.4). Specific customer order wiring schematics and diagrams are included with each circuit breaker.

There may be different control voltages or more than one tripping device, but the principal mode of operation is as follows:

As soon as the control power is applied, the spring charging motor automatically starts charging the closing spring. When the springs are charged, the motor cut off LS1/bb switch turns the motor off. The circuit breaker may be closed by closing the control switch close (CS/C) contact. Automatically upon closing of the circuit breaker, the motor starts charging the closing springs. The circuit breaker may be tripped any time by closing the control switch (CS/T) contacts.

Note the position switch (PS1) contact in the spring release circuit in the scheme. This contact remains closed while the circuit breaker is being racked between the ‘Test’ and ‘Connect’ positions for VR-Series+ circuit breakers. Consequently, it prevents the circuit breaker from closing automatically, even though the control close contact may have been closed while the circuit breaker is racked to the ‘Connect’ position.

When the CS/C contact is closed, the SR closes the circuit breaker. If the CS/C contact is maintained after the circuit breaker closes, the Y relay is picked up. The Y/a contact seals in Y until CS/C is opened. The Y/b contact opens the SR circuit, so that even though the circuit breaker would subsequently open, it could not be reclosed before CS/C was released and remade. This is the anti-pump function.

4.4.1 TIMING

The opening and closing times for the circuit breakers vary depending upon the control voltage, power rating, environment and test equipment. Differences in timing are expected between initial factory measurements and field inspections. Circuit breaker timing can be measured by service personnel using available equipment before installation and in conjunction with regular maintenance periods to assist in tracking the general health of the circuit breaker. Typical ranges as observed using nominal control voltages are listed in Table 4.

Table 4. Time Per Event

Event	Milliseconds
Closing Time (From Initiation of Close Signal to Contact Make)	45 - 60
Opening Time (Initiation of Trip Signal to Contact Break)	30 - 38
Reclosing Time (Initiation of Trip Signal to Contact Make)	140 - 165

Note: Values are typical at nominal rated control voltage(s).

4.6 SECONDARY CONNECTION BLOCK

The circuit breaker control circuit is connected to the switchgear control through the secondary connection block, located at the lower left of the circuit breaker. The contacts engage automatically when the circuit breaker is racked into the ‘Test’ and ‘Connect’ positions. The socket half of the connection is located in the circuit breaker compartment and a jumper of multiconductor cable can complete the control connections (for testing) when the circuit breaker is withdrawn from the circuit breaker compartment.

4.7 INTERLOCKS

⚠ DANGER

INTERLOCKS ARE PROTECTIVE DEVICES FOR PERSONNEL AND EQUIPMENT. DO NOT BYPASS, MODIFY, OR DISABLE ANY INTERLOCKS. DOING SO COULD CAUSE DEATH, SEVERE PERSONAL INJURY, EQUIPMENT DAMAGE AND/OR IMPROPER OPERATION.

There are several interlocks built into the VR-Series+ vacuum replacement circuit breakers. Each of these interlocks, though different in form, duplicate or exceed the function of the original circuit breaker’s interlocks. These interlocks exist to safeguard personnel and equipment. The basic premise behind the interlocking arrangement on the vacuum replacement circuit breaker is that the circuit breaker must not be inserted into or removed from a live circuit while the main contacts are closed. Also considered in the interlocking is that the circuit breaker should pose no greater risk than necessary to the operator in or out of the circuit breaker compartment.

Figure 4.3. Secondary Disconnect Contact Block

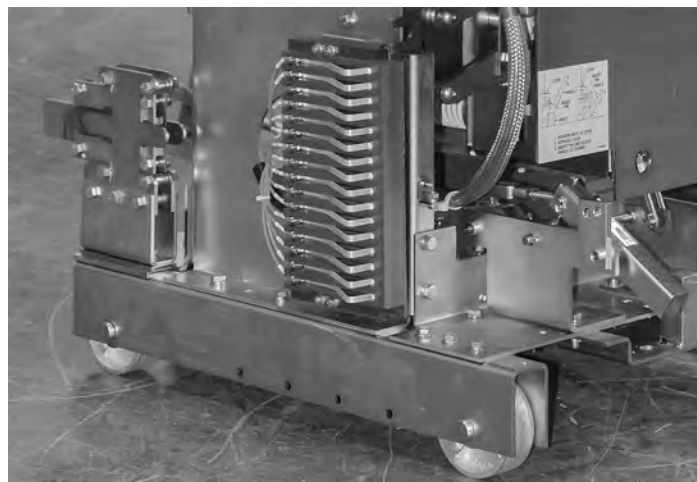
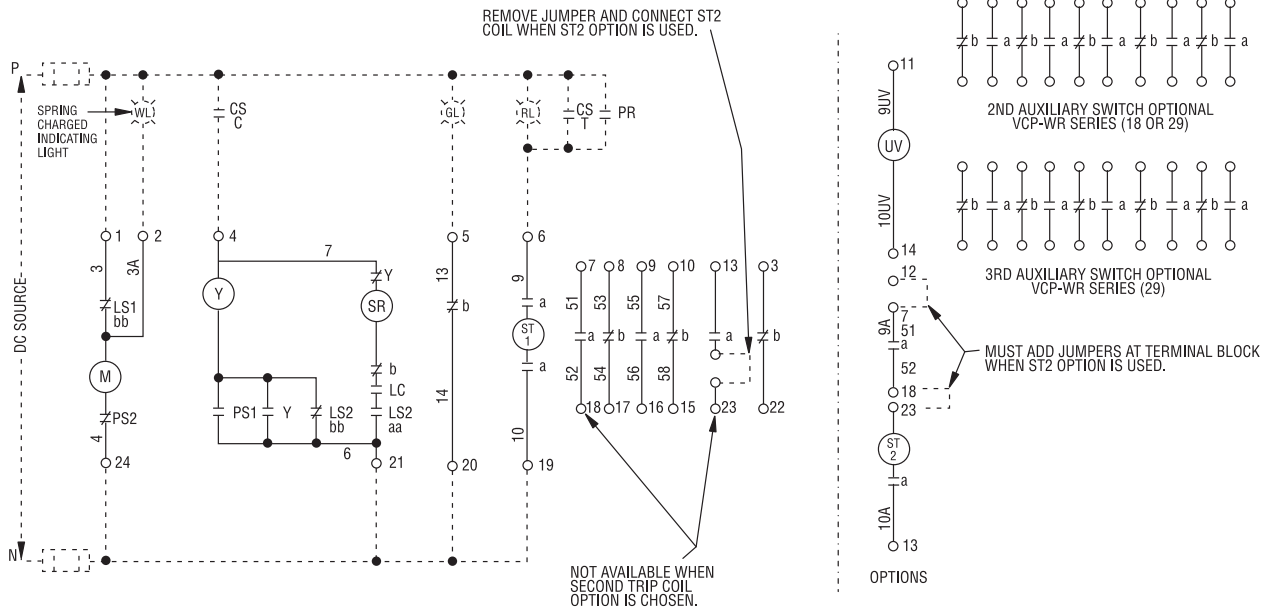
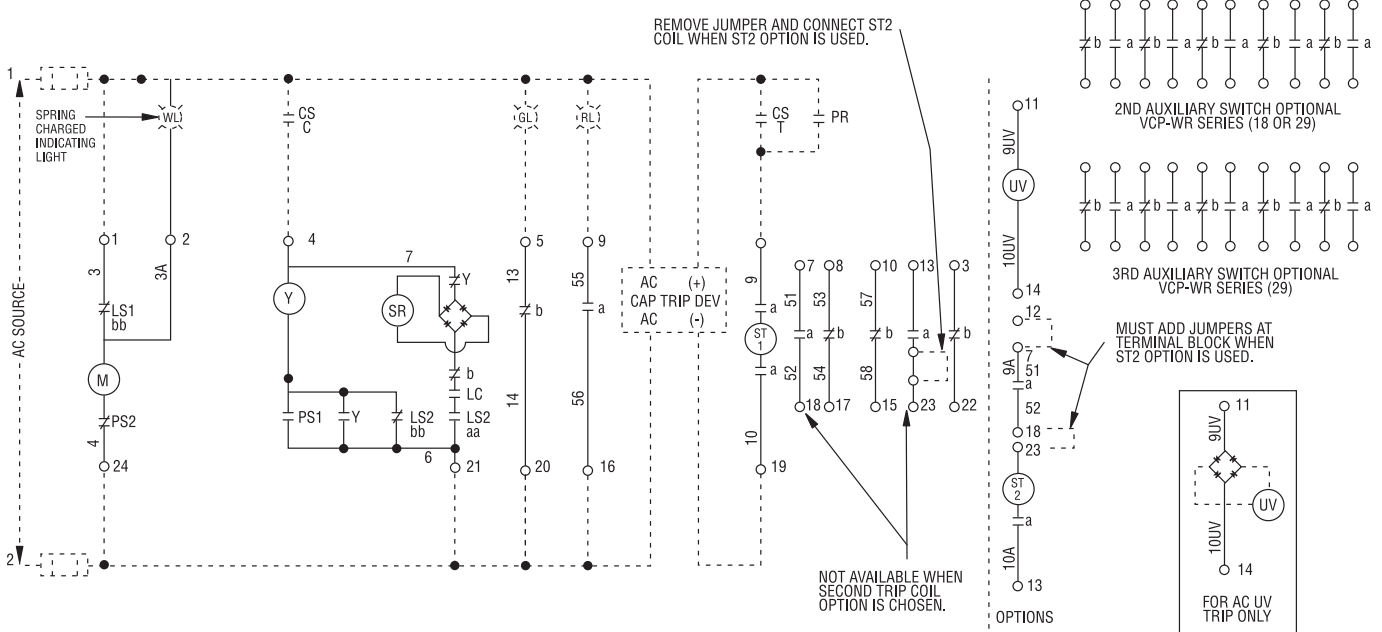

Figure 4.4. Typical ac/dc Schematic

VR-Series+ Circuit Breaker dc Control Schematic



VR-Series+ Circuit Breaker ac Control Schematic



- CS - Circuit Breaker Control Switch - close
- C
- CS - Circuit Breaker Control Switch - trip
- T
- Y - Anti Pump Relay
- SR - Spring Release Coil (Close Coil)
- M - Spring Charging Motor
- ST - Shunt Trip Coil
- PR - Protective Relay
- O - Terminal Block or Accessible Terminal
- PS1 - Position Switch 1
- PS2 - Position Switch 2

OPERATION

- LS1 bb - Closed until springs are fully charged
- LS2 aa - Open until springs are fully charged
- LS2 bb - Closed until springs are fully charged
- LC - Open until mechanism is reset
- PS1 - Open in all except between 'Test' and 'Connect' positions
- PS2 - Closed in all except between 'Test' and 'Connect' positions

SWITCH TERMINAL

- 'C' and 'NO' - Brown Switch
- 'C' and 'NC' - Black Switch
- 'C' and 'NO' - Black Switch
- 'C' and 'NC' - Black Switch
- 'C' and 'NO' - Brown Switch

MA-VR+ VR-Series+ Replacement Circuit Breaker

4.7.1 ANTI-CLOSE INTERLOCK

The anti-close interlock prevents discharging of the closing springs if the circuit breaker is already closed (Figure 4.7, Item 11). When the circuit breaker is closed, the interlock component moves away from the spring release clapper so that it cannot lift the spring release latch (9).

4.7.2 RACKING SYSTEM TRIP AND SPRING RELEASE INTERLOCKS

4.7.2.1 INTERNAL ROTARY RACKING

An active interlock is provided to keep the circuit breaker in a trip free position when the circuit breaker is between the test and fully connected position; no adjustments are necessary. In addition to the active interlock, two passive interlocks are provided; one to prevent engaging the rotary racking handle into the circuit breaker when the circuit breaker is closed, and one to prevent turning the rotary shaft in the circuit breaker when the circuit breaker is closed.

4.7.2.2 LEVERING HANDLE RACKING

Earlier revisions of the MA-VR+ supported the original Allis-Chalmers levering racking system. Information about this racking system can be found in Appendix A of this booklet.

4.7.3 SHUTTER OPERATING MECHANISM

The grounded aluminum shutters automatically close the opening to the cubicle primary disconnects when the circuit breaker is withdrawn from its connect position. The protective shutters guard against accidental human contact with the cubicle primary disconnect members. They also keep foreign matter from entering the disconnect chambers. Shutters are designed to remain closed until the movable primary disconnects on the circuit breaker are in position to enter the cubicle disconnect chambers.

The two shutter blades operate with a counterbalanced action. One blade moves up while the other moves down. This design requires a minimum of operating forces with smooth shutter operation. Blades are actuated through a common link bar and shutter roller by a guide on the right side of the circuit breaker frame.

4.8 MOC (Mechanically Operated Contacts) OPERATOR

The MOC operator located on the circuit breaker frame is linked to the **SURE CLOSE** MOC Operator. When the circuit breaker closes, regardless of whether it is in the cubicle, the MOC linkage of the circuit breaker will cause the exterior MOC operator to rapidly rise. Care should be exercised to avoid contact with this mechanism. Inside the cubicle, there is a lever system connected to a MOC switch. If the circuit breaker is in the 'Test' (on some designs) or 'Connect' position the MOC operator will operate the MOC switch when the circuit breaker closes. The MOC switch contains contacts which are used to interlock the circuit breaker with other external devices and can provide circuit breaker status indication.

⚠ WARNING

EXTREME CARE SHOULD BE TAKEN TO AVOID PERSONNEL OR EQUIPMENT CONTACT WITH THE MOC SYSTEM WHEN OPERATING THE CIRCUIT BREAKER DUE TO THE ASSOCIATED MECHANICAL FORCE. CONTACT WITH THE MOC OPERATOR DURING OPERATION COULD RESULT IN INJURY.

4.9 TOC (Truck Operated Contacts) OPERATOR

The TOC switch, normally located on the right rear side of the cubicle, is operated by the circuit breaker truck frame. If the circuit breaker is fully racked into the cell, the truck frame operates the paddle of the TOC switch. The TOC switch contains contacts which are used to interlock the circuit breaker with other external devices and provide remote indication of circuit breaker position (Figure 4.5). Adjust TOC switch as necessary for proper operation prior to inserting any replacement circuit breaker.

Figure 4.5. Cell TOC Switch

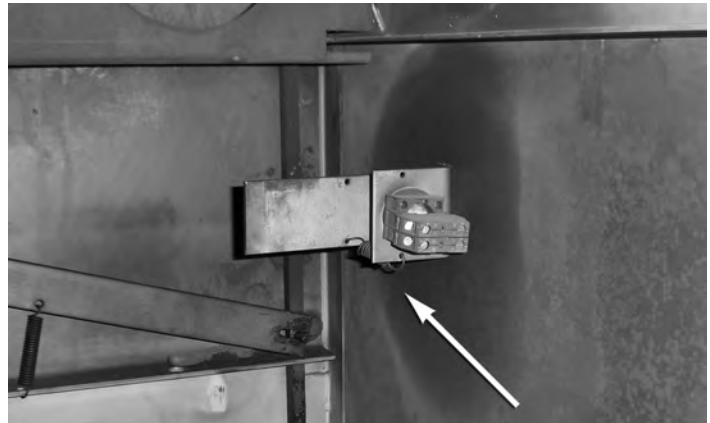

⚠ WARNING

DO NOT FORCE THE CIRCUIT BREAKER INTO THE CELL. DOING SO MAY DAMAGE PARTS THEREBY RISKING DEATH, PERSONAL INJURY, AND/OR PROPERTY DAMAGE.

4.10 RACKING MECHANISM

4.10.1 INTERNAL ROTARY RACKING

The internal rotary racking system is a safety improvement to the original method of levering (inserting and removing) medium voltage circuit breakers. Each circuit breaker, when properly equipped, can be racked from 'Disconnect' to 'Test' and then to 'Connect' using a levering crank to rotate an onboard screw driven mechanism. For the specifics of the racking process, see Section 5 of this instruction book. The rotary racking system also interfaces with Eaton's RPR-2 Remote Power Racking system to allow the operator to be 25 feet or more away from the door during the process of insertion or removal.

4.10.2 LEVERING HANDLE RACKING

Earlier revisions of the MA-VR+ supported the original method of levering racking system. Information about this racking system can be found in Appendix A of this booklet.

4.11 GROUNDING CONTACT

The grounding contact is an assembly of spring loaded fingers which ground the circuit breaker frame (static ground) by engaging the switchgear grounding bus when the circuit breaker is racked into the circuit breaker compartment. The ground contact is located at the rear of the circuit breaker and visible from the back of the circuit breaker when out of the circuit breaker compartment. (Figure 3.3.b)

4.12 MISCELLANEOUS ITEMS

4.12.1 OPERATIONS COUNTER

All MA-VR+ circuit breakers are equipped with a mechanical operations counter (Figure Set 3.3). As the circuit breaker opens, the linkage connected to the pole shaft lever advances the counter reading by one.

Figure 4.6. VR-Series+ Circuit Breaker Element Mechanism - Front Cover Removed

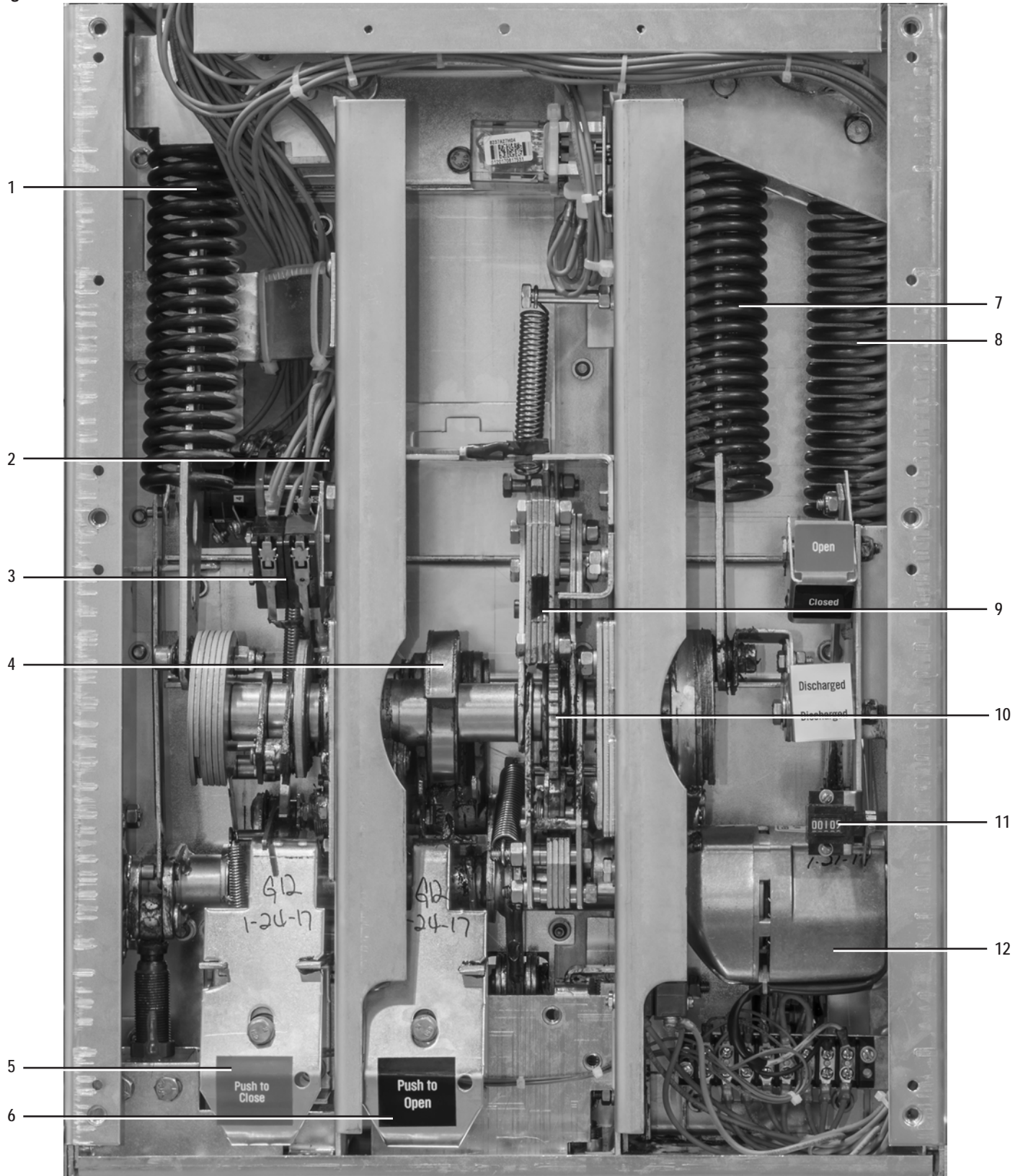

VR-Series+ Circuit Breaker Element Mechanism

1	LH Closing Spring	5	Spring Release Assembly	9	Manual Charge Socket
2	Latch Check Switch (To Rear of Motor Cutoff Switch)	6	Shunt Trip Assembly	10	Ratchet wheel
3	Motor Cutoff Switch	7	RH Closing Spring	11	Operations Counter
4	Closing Cam	8	Reset / Opening Spring	12	Charging Motor

MA-VR+
VR-Series+ Replacement Circuit Breaker

Figure 4.7. Closing Cam and Trip Linkage

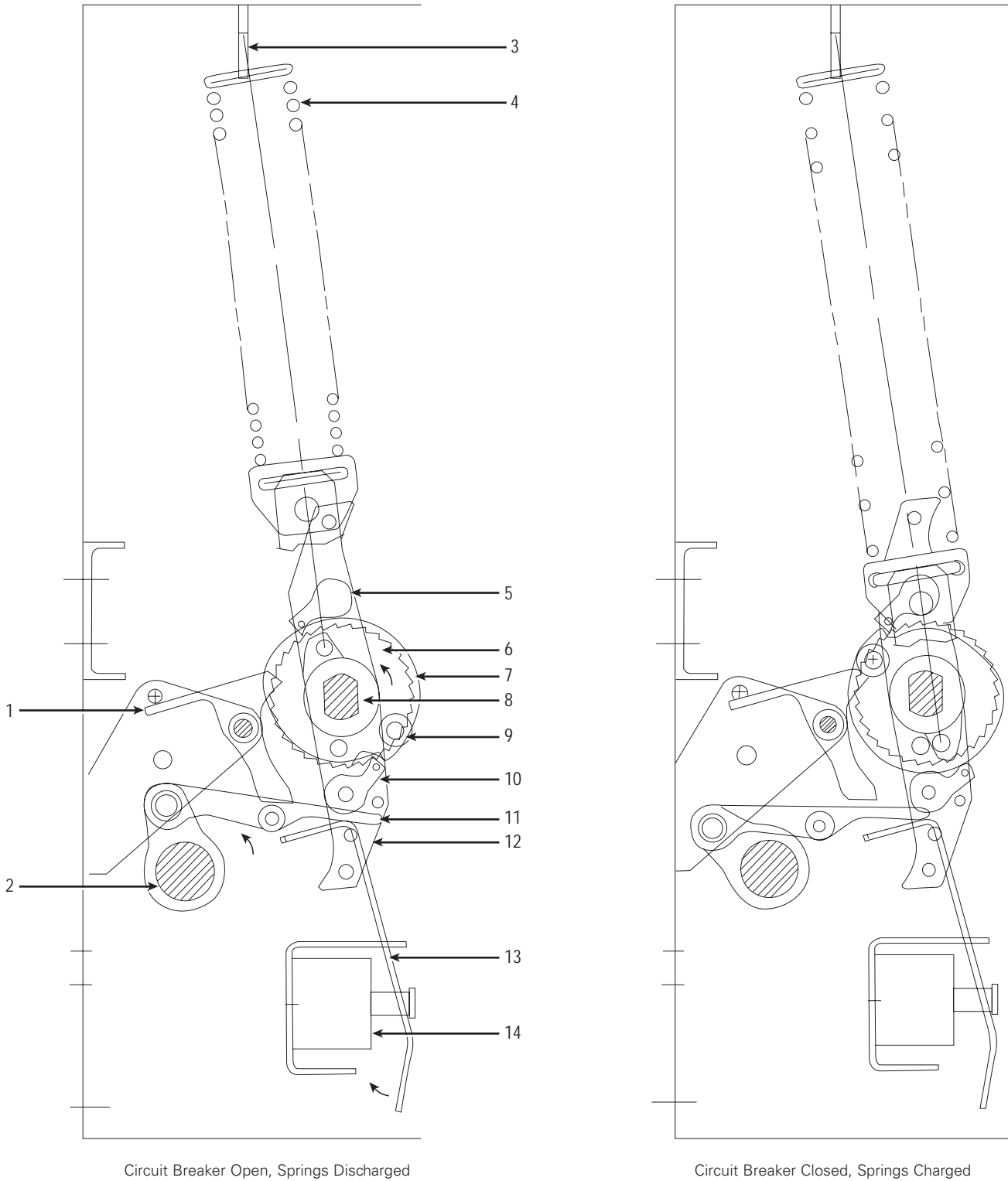

Closing Cam and Trip Linkage

1	Spring Release (Close) Latch	6	Ratchet Wheel	11	Anti-Close Interlock
2	Pole Shaft	7	Spring Crank	12	Motor Ratchet Lever
3	Closing Spring Fixed End	8	Cam Shaft	13	Spring Release (Close) Clapper
4	Closing Spring	9	Spring Release Latch (Close Roller)	14	Spring Release (Close) Coil
5	Holding Pawl	10	Drive Pawl		

Figure 4.8. Charging Schematic

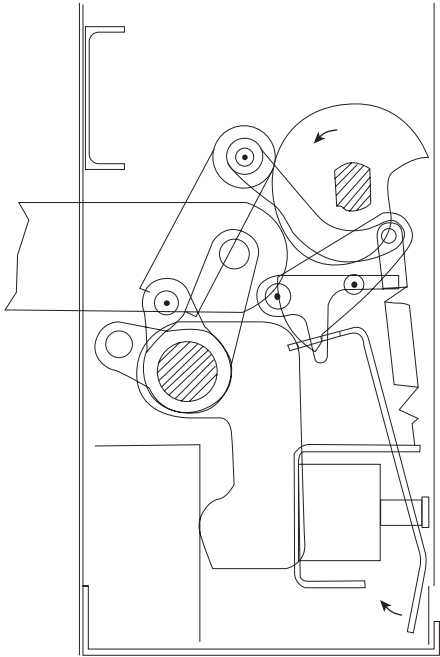

4.8.a. Circuit Breaker Open and Closing Spring Not Charged

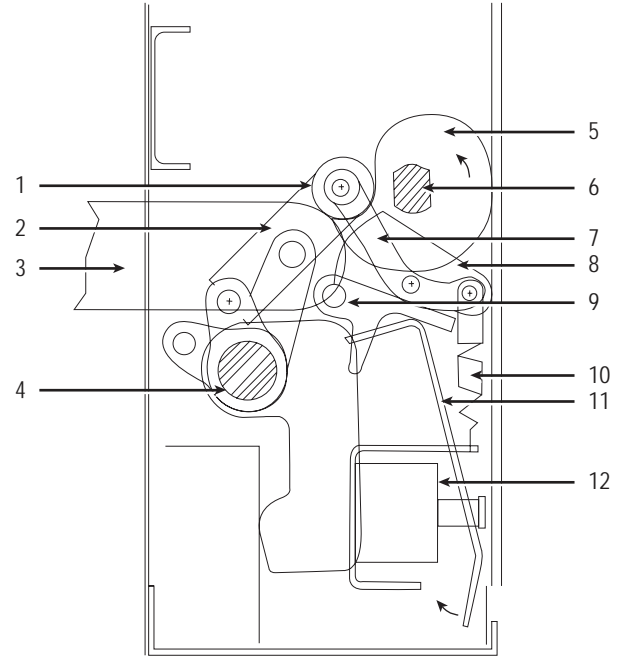

4.8.b. Circuit Breaker Open and Closing Spring Charged

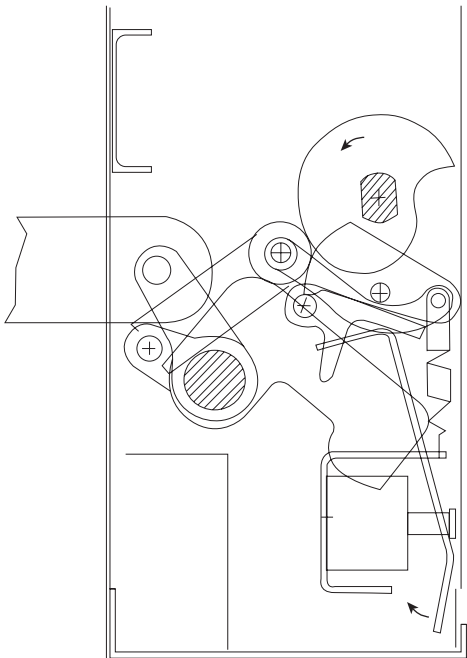

4.8.c. Circuit Breaker Closed and Closing Spring Not Charged

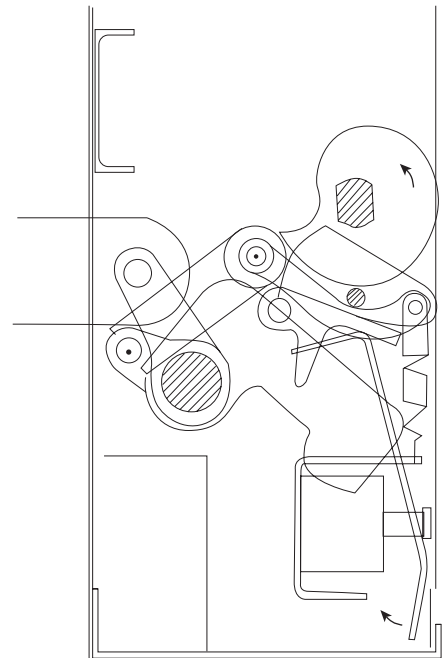

4.8.d. Circuit Breaker Closed and Closing Spring Charged

Charging Schematic

1	Main Link Roller	5	Closing Cam	9	Trip Bar "D" Shaft
2	Main Link	6	Cam Shaft	10	Trip Latch Reset Spring
3	Operating Rod	7	Banana Link	11	Shunt Trip Lever
4	Pole Shaft	8	Trip latch	12	Shunt Trip Coil

SECTION 5: INSPECTION & INSTALLATION

⚠ WARNING

BEFORE PLACING THE CIRCUIT BREAKER IN SERVICE, CAREFULLY FOLLOW THE INSTALLATION PROCEDURE BELOW AND THE SAFE PRACTICES SET FORTH IN SECTION 2. NOT FOLLOWING THE PROCEDURE MAY RESULT IN INCORRECT CIRCUIT BREAKER OPERATION LEADING TO DEATH, BODILY INJURY, AND PROPERTY DAMAGE.

When the circuit breaker is first commissioned into service and each time the circuit breaker is returned to service, it should be carefully examined and checked to make sure it is operating correctly.

5.1 EXAMINATION FOR DAMAGE

Examine the circuit breaker for loose or obviously damaged parts. Never attempt to install nor operate a damaged circuit breaker.

5.1.1 NAMEPLATE VERIFICATION

Verify the information on the new VR-Series+ nameplate matches the information on the purchase order. If any discrepancies exist, notify Eaton's Electrical Services & Systems for resolution prior to proceeding.

⚠ WARNING

ALWAYS DE-ENERGIZE/ISOLATE THE POWER SOURCE FEEDING THE CIRCUIT BREAKERS/SWITCHGEAR AND LOCK-OUT/TAG-OUT THE POWER SOURCE PRIOR TO INSERTION OR REMOVAL OF ANY CIRCUIT BREAKER. NEVER ATTEMPT TO MAINTAIN OR MODIFY A CIRCUIT BREAKER WHILE INSERTED IN A SWITCHGEAR CELL STRUCTURE. ALWAYS REMOVE THE CIRCUIT BREAKER AND MOVE IT TO A SUITABLE AREA FOR MAINTENANCE OR REPAIR.

FOLLOW ALL LOCKOUT AND TAG-OUT REQUIREMENTS OF THE NATIONAL ELECTRIC CODE, OSHA AND ANY OTHER APPLICABLE LOCAL CODES, REGULATIONS AND PROCEDURES.

5.2 CELL CODE / REJECTION PLATE INSTALLATION

Cell code plates and air circuit breaker rejection plates may be required to reject circuit breakers that do not match the electrical rating structure of the existing cell. If the momentary rating of a replacement circuit breaker is increased, a code plate and a cell rejection plate must be installed to accept the new replacement circuit breaker and reject all others of lesser ratings. If momentary ratings of the new replacement circuit breakers are the same as the original circuit breakers, then the original cell code plate may be retained.

Figure 5.1. Cell Code / Rejection Plate Mounting (1200A)

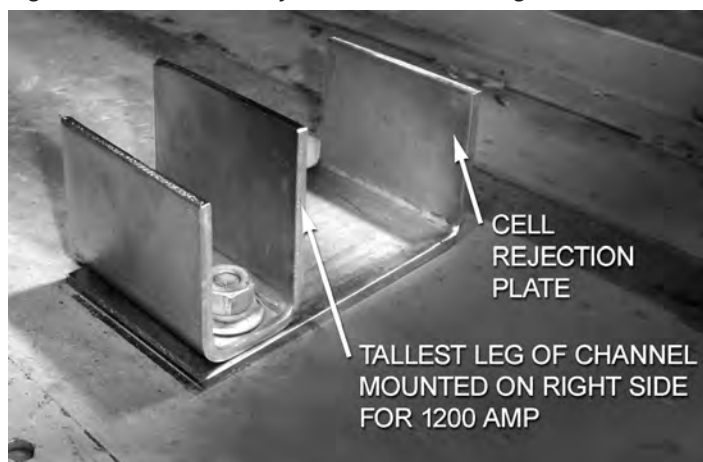
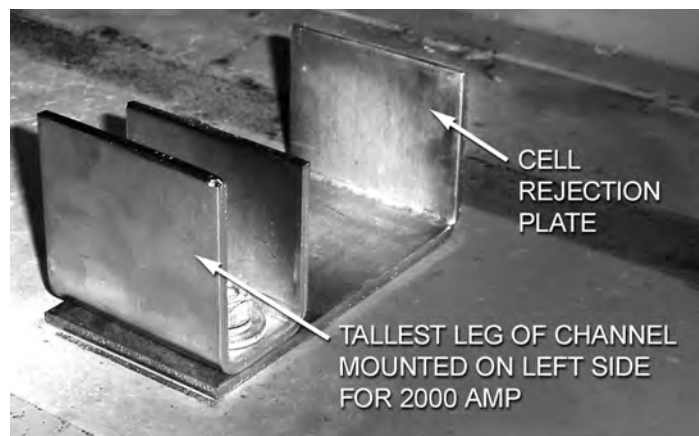

Figure 5.2. Cell Code / Rejection Plate Mounting (2000A)



A circuit breaker code plate is factory installed on VR-Series+ circuit breakers. Cell code plates are automatically furnished with each replacement circuit breaker when increased momentary ratings are supplied. When a cell air circuit breaker rejection plate is not required, a shim plate is provided to space up the cell code plate to the proper height.

The tallest leg of the channel is mounted on the right hand side for the 1200 Amp circuit breakers and on the left hand side for 2000 Amp.

⚠ NOTICE

IF CELL CODE PLATES ARE INSTALLED INCORRECTLY THE INTERLOCKS WILL NOT DISCHARGE AT INSERTION OF THE CIRCUIT BREAKER RESULTING IN INCORRECT CIRCUIT BREAKER OPERATION LEADING TO DEATH, BODILY INJURY, AND PROPERTY DAMAGE.

5.3 SURE CLOSE MECHANISM ADJUSTMENT

⚠ WARNING

FOR ALL TYPE CIRCUIT BREAKER HOUSINGS EQUIPPED WITH MECHANISM OPERATED CELL (MOC) SWITCHES, THE STEPS OUTLINED IN THIS SECTION MUST BE PERFORMED BEFORE INSTALLING A REPLACEMENT VR-SERIES+ CIRCUIT BREAKER. FAILURE TO COMPLY COULD CAUSE SEVERE PERSONAL INJURY, DEATH, EQUIPMENT DAMAGE AND/OR IMPROPER OPERATION

All type MA-VR+ circuit breakers with MOC operators utilize the **SURE CLOSE** mechanism to control kinetic energy transfer and closely mimic the dynamics and velocities of older circuit breakers. It is imperative that this mechanism be adjusted to compensate for the force of the MOC switch mounted in the cell.

The circuit breaker **SURE CLOSE** MOC operator is factory adjusted to a force of 37-52 lbf. This force has been proven to successfully operate a well-maintained Allis-Chalmers 8-9 stage MOC switch provided it does not have excessive pitting or arcing on its contacts. The parameters for the existing MOC switch should be verified and adjustments made to the cell switch mounting location. Do not attempt to insert or operate a MA-VR+ replacement circuit breaker in a cell containing an MOC until after the switch has been properly adjusted. See Figure 5.3.b for cell MOC location dimensions.

⚠ WARNING

MEASUREMENTS AND ADJUSTMENTS SHOULD NEVER BE ATTEMPTED IN AN ENERGIZED STRUCTURE. IF THE STRUCTURE CAN NOT BE DE-ENERGIZED, THEN PROPER PERSONAL PROTECTIVE EQUIPMENT PER NFPA 70E MUST BE WORN AT ALL TIMES WHILE GATHERING MOC SWITCH DATA, ADJUSTING OR SERVICING THE MOC SWITCH. FAILURE TO COMPLY WITH THIS WARNING COULD CAUSE SEVERE PERSONAL INJURY, DEATH, EQUIPMENT DAMAGE AND/OR IMPROPER OPERATION.

Figure 5.3.a. Cell MOC Location

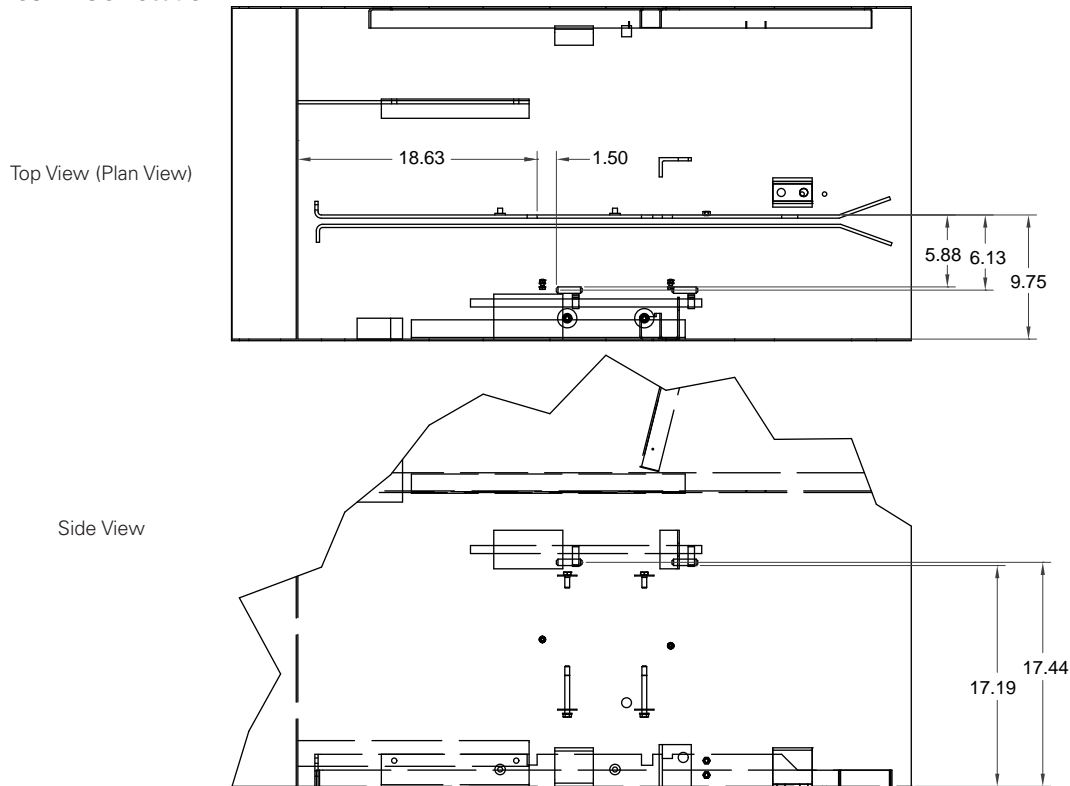

Figure 5.3.b. Cell Mounted MOC Operator



Figure 5.3.c. Cell MOC Force Measurement



Locate the cell mounted MOC. Two functional versions of the MOC interface are known to exist. One operates the MOC switch in the connected position only and the other will operate in either the "TEST" or "CONNECTED" positions. Figures 5.3.a shows the MOC switch that can operate in the "TEST" or "CONNECTED" positions.

To insure the proper operation of the **SURE CLOSE** mechanism, the MOC assembly should be cleaned and inspected for worn parts, lubricated and properly secured in the cell as indicated in Figure 5.3.b before proceeding. A spring force gauge should be used to measure the forces needed to move the switch to the fully closed position prior to inserting the circuit breaker.

Step 1: Attach a spring force gauge to the round operating rod as shown (Figure 5.3.c) and pull vertically until the switch contacts have all changed state. Do not "over-pull" on the gauge. Measure and record the force. It should be approximately 27-32 lbf for a properly maintained and adjusted Allis-Chalmers MOC switch with 8-9 stages. The force will be higher for switches with more stages or if improperly maintained.

Step 2: Place the circuit breaker at a safe distance from the cell structure and on a level surface. If the cell structure is energized,

be sure the circuit breaker is beyond the Arc Flash Boundary. Chock the wells to prevent movement. Use the maintenance tool to charge the stored energy mechanism and manually press the "PRESS TO CLOSE" device to close the circuit breaker.

Step 3: Attach the spring force gauge as shown in Figure 4.14 and pull down vertically (approximately .125 - .25") to measure the **SURE CLOSE** MOC operator force. It should measure between 37-52 lbf. This provides a minimum margin/differential of approximately 10 lbf to operate the MOC switch. If the differential force between the **SURE CLOSE** MOC operator and the MOC switch is less than 10 lbf, then the **SURE CLOSE** MOC operator force should be increased to obtain a 10 lbf differential between the force measure in the cell and the output force of the circuit breaker with the circuit breaker being the greater of the two forces. Proceed with the following steps to increase the circuit breaker **SURE CLOSE** MOC operator force:

Step 4: Open the circuit breaker by depressing the "PUSH TO OPEN" operator. Locate the **SURE CLOSE** MOC drive spring (Figure 3.4). It is located in the lower left portion of the circuit breaker as viewed from the primary bushing side of the circuit breaker.

Figure 5.4. **SURE CLOSE** Spring Compression Setting

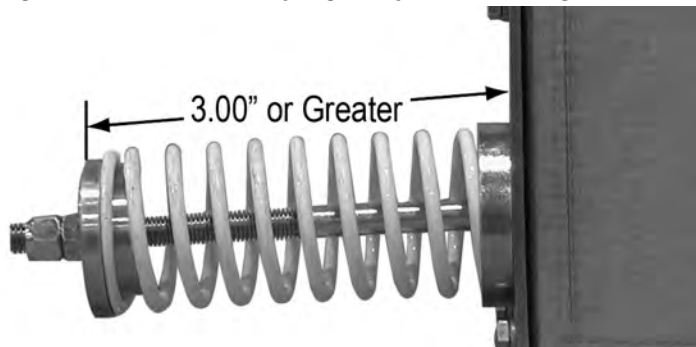

Figure 5.5. **SURE CLOSE** Spring Compression Setting

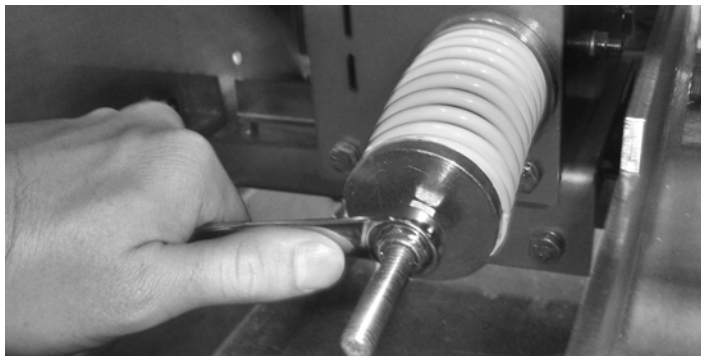

Figure 5.6. Measuring With Spring Force Gauge



Step 5: Loosen the outer jam nut on the **SURE CLOSE** spring and turn the inner nut clockwise to compress the spring an additional .25 inch. Measure and record the length of the compressed length of the spring. It should never be compressed to less than 3.00 inches. Charge the circuit breaker's stored energy mechanism using the "maintenance tool" and close the circuit breaker by depressing the "PUSH TO CLOSE" operator.

Step 6: With the circuit breaker still out of the cell and in the closed position, measure the output of the MOC drive as described in Step 3. The MOC drive force should exceed the MOC cell force requirement by a minimum of 10 lbf. If not, repeat Steps 4 - 6 until the required margin is achieved. Do not compress the spring beyond 3.00 inches as referenced in Figure 4.12 and Step 5.

Step 7: Manually charge and close the circuit breaker 2-3 times to stabilize the reactions of the circuit breaker components. Close the circuit breaker and measure the MOC output force as described in Step 3. If the force margin remains adequate, proceed to the next step. If not, repeat adjustment Steps 4 - 6. Tighten the jam nut (Figure 4.13) when adjustments are completed.

Step 8: Insert into the cell following the instructions for the correct vintage (See Section 4).

Step 9: Operate the circuit breaker to verify the MOC operator force is sufficient when driving all the MOC system components.

Step 10: Repeat Steps 3 - 8 until acceptable operation is achieved.

Step 11: Anytime an adjustment is made, make sure the new compressed spring length (measured in the open position) is recorded if different from the dimension as received from the factory.

Step 12: After an adjustment is made, always verify that all nuts are secured in place, prior to returning to service.

5.4 PRE-INSTALLATION CELL CHECK

5.4.1 SELF-ADJUSTING ANTI-ROTATION SYSTEM ADJUSTMENT (For all MA-VR+ Designs)

All MA-VR+ designs manufactured after March 2007 come with a self-adjusting Anti-rotation system. As long as the cell is equipped with a shutter guide bracket mounted at approximately 12 inches (+/- 0.25") from the cell floor to the bottom of the shutter guide bracket, no adjustments are required (Figure 4.1). If your cell is not within these limits, contact your local Eaton Electrical Services and Systems representative prior to attempting to install any MA-VR+

Figure 5.7. Shutter Guide Bracket

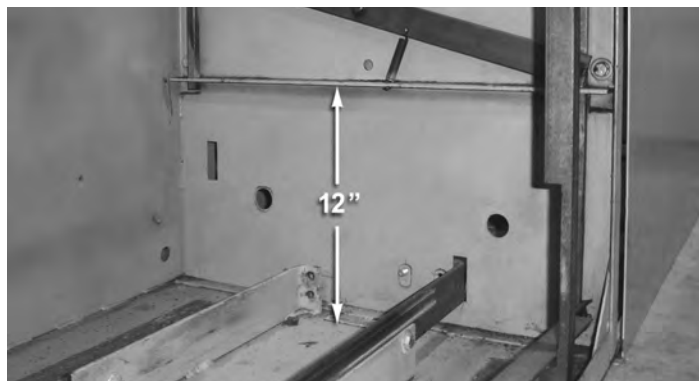

Figure 5.8. Self-Adjusting Anti-Rotation Device



circuit breaker. (See Figure 4.2)

5.5 OPTIONAL SECONDARY CONNECTION BLOCK EXTENSION CABLE

Refer to Appendix B in this manual for proper installation and operation of the optional secondary connection block extension cable.

5.6 OPERATIONAL POSITIONS

The circuit breaker has four basic operational positions:

- (1) Circuit Breaker withdrawn from cell. (Figure 5.9)
- (2) Circuit Breaker in the cell in the disconnect position.
- (3) Circuit Breaker in the test position. (Figure 5.12)
- (4) Circuit Breaker in the connect position. (Figure 5.13)

⚠ WARNING

ARC FLASH INCIDENTS WITH MV SWITCHGEAR CAN OCCUR DURING THE PROCESS OF INSERTING AND REMOVING CIRCUIT BREAKERS IN SWITCHGEAR CUBICLES. IT IS STRONGLY RECOMMENDED THAT PROPER PPE (PERSONAL PROTECTIVE EQUIPMENT) BE WORN BY PERSONNEL WHO RACK CIRCUIT BREAKERS USING THE MANUAL LEVERING HANDLE OR THE ROTARY RACKING HANDLE. EATON CORPORATION PROVIDES A UNIVERSAL REMOTE POWER RACKING SYSTEM (RPR-2) WHICH IS COMPATIBLE WITH THE INTERNAL ROTARY RACKING CIRCUIT BREAKERS. THIS SYSTEM MAY ALLOW PERSONNEL TO WEAR A LOWER LEVEL OF PPE DURING THE INSERTION OR REMOVAL PROCESS AS LONG AS RACKING CAN BE PERFORMED FROM OUTSIDE THE FLASH PROTECTION BOUNDARY.

5.7 INTERNAL ROTARY RACKING

5.7.1 INSERTION PROCEDURE

- a. Place the circuit breaker in the withdrawn position; verify the circuit breaker position indicator indicates the circuit breaker is in the disconnect position.

⚠ WARNING

THE CIRCUIT BREAKER CAN BE OPERATED WHEN WITHDRAWN FROM THE CELL, HOWEVER, THE ROTARY RACKING HANDLE MUST BE USED TO RACK THE CIRCUIT BREAKER TO THE TEST POSITION, AS SHOWN ON THE CIRCUIT BREAKER POSITION INDICATOR. THE CIRCUIT BREAKER MUST BE RACKED TO THE DISCONNECT POSITION, AS SHOWN ON THE CIRCUIT BREAKER POSITION INDICATOR, BEFORE INSERTING IT INTO THE CELL.

- b. From the withdrawn position, align the guide bar of the circuit breaker with the guide rails of the cell.
- c. Check that the closing spring status indicator reads "DISCHARGED" and that the main contact status indicator reads "OPEN".
- d. Push the circuit breaker into the cell until the mechanical stop is reached, this will be indicated by an audible click. At this point the front plunger has fallen into the front slot of the guide rail. In this position the circuit breaker cannot be operated. Verify the circuit breaker position indicator, as well as the cell position indicator, both indicate the circuit breaker to be in the disconnect position. This position can also be verified by the ability to raise the racking access handle.
- e. To further advance the circuit breaker into the cell, raise the racking access handle by pulling it up and over to the right so that it rests in the right hand side of the slot to expose the racking nut. When racking nut is exposed, insert rotary racking handle and turn clockwise. (Figure 5.9) The circuit breaker will travel approximately 1.5 inches to reach the test position. The circuit breaker may be stopped in the test position, as indicated by the circuit breaker

Figure 5.9. Racking Access Handle



and cell position decals, if electrical or mechanical testing is to be performed. Remove rotary racking handle before performing any testing.

⚠ NOTICE

ONCE THE SECONDARY DISCONNECT BLOCK IS ENGAGED IN THE "TEST" POSITION, IT WILL REMAIN CONNECTED THROUGHOUT FURTHER INWARD MOVEMENT AS THE CIRCUIT BREAKER ADVANCES FROM THE "TEST" TO THE "CONNECT" POSITION.

THE SPRING CHARGING MOTOR WILL BEGIN TO RUN, IF THE MOTOR CUT-OFF SWITCH IS IN THE "ON" POSITION (FIGURE 3.4), AND CHARGE THE CLOSING SPRINGS AS THE SECONDARY TEST POSITION IS MADE AS LONG



MA-VR+ VR-Series+ Replacement Circuit Breaker

- f. From the test position, the circuit breaker can be advanced to the connect position by reinserting the rotary racking handle. Rotate racking handle clockwise until the connect position is reached and the handle can no longer be turned. This can be verified by the circuit breaker position indicator, as well as the cell position decal.

**Figure 5.11. Circuit Breaker Position Indicator
(Shown With Circuit Breaker In 'Connect' Position)**

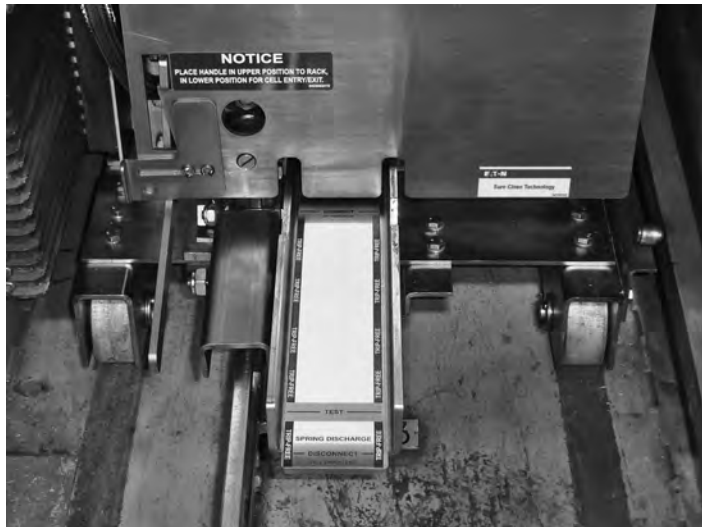

Figure 5.12. Circuit Breaker in the 'Connect' Position



5.7.2 REMOVAL PROCEDURE

- a. To remove the circuit breaker from the cell, it must be in the open position and the racking access handle in the top right slot; interlocking will prevent removal if the circuit breaker is closed. Engage the rotary racking handle into the racking nut. Rotate the rotary racking handle counter-clockwise to move the circuit breaker out of the cell. The shutters will start to close after the primary stabs have cleared, isolating the circuit breaker from its source. Continue rotating racking handle counter-clockwise until the position indicators on the circuit breaker and cell indicate test position. In test position the circuit breaker can be operated either electrically or mechanically. Remove rotary racking handle before performing any testing.
- b. To further remove the circuit breaker to the disconnect position continue turning the rotary racking handle in the counter-clockwise direction. If the circuit breaker was inadvertently left charged in the test position, the springs will discharge as the circuit breaker is racked to the disconnect position, resulting in a loud noise. The circuit breaker will be in the disconnect position when the rotary racking handle can no longer be turned with normal force, and the circuit breaker and cell position decals indicate disconnect position. At this point, the circuit breaker will be open with the springs discharged.
- c. If the circuit breaker is to be withdrawn from the cell, lower the racking access handle then depress the interlock pedal while pulling the circuit breaker out of the cell using the handles on the front of the circuit breaker.

SECTION 6: INSPECTION & MAINTENANCE

⚠ DANGER

DO NOT WORK ON A CIRCUIT BREAKER IN THE 'CONNECT' POSITION.

DO NOT WORK ON A CIRCUIT BREAKER WITH SECONDARY DISCONNECTS ENGAGED.

DO NOT WORK ON A CIRCUIT BREAKER WITH SPRINGS CHARGED OR CONTACTS CLOSED.

DO NOT DEFEAT ANY SAFETY INTERLOCKS.

DO NOT LEAVE MAINTENANCE TOOL IN THE SOCKET AFTER CHARGING THE CLOSING SPRINGS.

STAND AT LEAST ONE METER AWAY FROM THE CIRCUIT BREAKER WHEN TESTING FOR VACUUM INTEGRITY.

⚠ DANGER

FAILURE TO FOLLOW ANY OF THESE INSTRUCTIONS MAY CAUSE DEATH, SEVERE PERSONAL INJURY, EQUIPMENT DAMAGE AND/OR IMPROPER OPERATION. SEE SECTION 2 - SAFE PRACTICES FOR MORE INFORMATION.

6.1 INSPECTION FREQUENCY

The scheduled maintenance interval for the VR-Series+ circuit breaker is once every ten years or ten thousand operations, whichever comes first when applied in normal applications as defined by IEEE C37.04-1999. However, if the circuit breaker is operating in a high level of natural elements or in a corrosive environment, inspection should be performed twice each year. The circuit breaker should also be inspected and a vacuum interrupter integrity test performed (Section 6.3) any time the circuit breaker is transported to another physical location or switchgear assembly. In addition, the circuit breaker should have a full inspection if the circuit breaker interrupts a fault current.

Note: Refer to the table below for maintenance and inspection check points.

6.2 INSPECTION AND MAINTENANCE PROCEDURES

NO. / SECTION	INSPECTION ITEM	CRITERIA	INSPECTION METHOD	CORRECTIVE ACTION IF NECESSARY	
1. Insulation	Stand Off Insulators, Operating Rods, Tie-Bars and Barriers	No dirt	Visual check	Clean with lint-free cloth	
		No cracking	Visual check	Replace cracked unit	
	Vacuum Integrity	Between main circuit with terminals ungrounded	Withstand 27kV 60Hz for 1 Minute	Hi-pot Tester	Clean and retest or replace
	Insulation Integrity	Main circuit to ground	Withstand 15kV, 60Hz for 1 Minute (5kV Rating)	Hi-pot Tester	Clean and retest or replace
Control circuit to ground (Charging Motor disconnected)		Withstand 1125V, 60Hz for 1 Minute	Hi-pot Tester	Clean and retest or replace	
2. Power Element	Vacuum Interrupter Assembly	Contact erosion visibility	Visual - Close the circuit breaker and look for "T" cutout on Vacuum Interrupter Assembly (See Figure 6.1 and 6.2)	If cutout is not visible, replace Vacuum Interrupter Assembly	
		Contact wipe visible	Visual (Figure 6.1 and 6.2)	Replace Vacuum Interrupter Assembly	
		Adequate vacuum	See Section 6.3	Replace Vacuum Interrupter Assembly If vacuum is not adequate	
		Dirt on ceramic body	Visual check	Clean with dry lint-free cloth	
	Primary Disconnects	No burning or damage	Visual check	Replace if burned, damaged or eroded	
3. Control Circuit Parts	Closing and tripping devices including disconnects	Smooth and correct operation by control power	Test closing and tripping of the circuit breaker twice	Replace any defective device - Identify per Trouble-Shooting Chart	
	Wiring	Securely tied in proper place	Visual check	Repair or tie as necessary	
	Terminals	Tight	Visual check	Tighten or replace if necessary	
	Motor	Smooth and correct operation by control power	Test closing and tripping of the circuit breaker twice	Replace brushes or motor	
	Tightness of hardware	No loose or missing parts	Visual and tightening with appropriate tools	Tighten or reinstate if necessary	
4. Operating Mechanism	Dust or foreign matter	No dust or foreign matter	Visual check	Clean as necessary	
	Deformation or excessive wear	No excessive deformation or wear	Visual and operational	Remove cause and replace parts	
	Manual operation	Smooth operation	Manual charging closing and tripping	Correct per Trouble-Shooting Chart if necessary	
	CloSure™ Test	≥ 0.6 inch over travel	CloSure™ Test 6.8.1	If < 0.6 Contact the PBC at 1-877-276-9379	

Note: Contact Eaton for any mechanism maintenance other than adjustment or replacement of control components.

BOLT SIZE	8 - 32	10 - 32	.25 - 20	.31 - 18	.38 - 16	.50 - 13
TORQUE Lbs. In.	24	36	72	144	300	540

MA-VR+ VR-Series+ Replacement Circuit Breaker

6.3 VACUUM INTERRUPTER INTEGRITY TEST

Vacuum interrupters used in Type VR-Series+ circuit breakers are highly reliable interrupting components. Satisfactory performance of these devices is dependent upon the integrity of the vacuum in the interrupter and the internal dielectric strength. Both of these parameters can be readily checked by a one minute ac high potential test. (See Table 6.1 for appropriate test voltage.) During this test, the following warnings must be observed:

⚠ WARNING

APPLYING ABNORMALLY HIGH VOLTAGE ACROSS A PAIR OF CONTACTS IN VACUUM MAY PRODUCE X-RADIATION. THE RADIATION MAY INCREASE WITH THE INCREASE IN VOLTAGE AND/OR DECREASE IN CONTACT SPACING. X-RADIATION PRODUCED DURING THIS TEST WITH RECOMMENDED VOLTAGE AND NORMAL CONTACT SPACING IS EXTREMELY LOW AND WELL BELOW MAXIMUM PERMITTED BY STANDARDS. HOWEVER, AS A PRECAUTIONARY MEASURE AGAINST POSSIBILITY OF APPLICATION OF HIGHER THAN RECOMMENDED VOLTAGE AND/OR BELOW NORMAL CONTACT SPACING, IT IS RECOMMENDED THAT ALL OPERATING PERSONNEL STAND AT LEAST ONE METER AWAY IN FRONT OF THE CIRCUIT BREAKER.

⚠ WARNING

DC HI-POTENTIAL TESTS ARE NOT RECOMMENDED BY EATON. DO NOT APPLY DC AT ANY LEVEL TO VR-SERIES+ CIRCUIT BREAKERS

With the circuit breaker open and securely sitting on the floor, connect all top/front primary studs (bars) together and the high potential machine lead. Connect all bottom/rear studs together and the high potential return lead. Do not ground them to the circuit breaker frame. Start the machine at zero potential, increase to appropriate test voltage and maintain for one minute.

Successful withstand indicates that all interrupters have satisfactory vacuum level. If there is a breakdown, the defective interrupter or interrupters should be identified by an individual test and replaced before placing the circuit breaker in service.

After the high potential is removed, discharge any electrical charge that may be retained, particularly from the center shield of vacuum interrupters. To avoid any ambiguity in the ac high potential test due to leakage or displacement (capacitive) current, the test unit should have sufficient volt-ampere capacity. It is recommended that the equipment be capable of delivering 25 milliamperes for one minute.

The current delivery capability of 25 mA ac applies when all three vacuum interrupters are tested in parallel. If individual vacuum interrupters are tested, current capability may be one third of this value.

Table 6.1. Vacuum Interrupter Integrity Test Voltage

Circuit Breaker Rated Maximum Voltage	Vacuum Interrupter Integrity Test Voltage
	ac 60Hz
Up to and including 15.0 kV	27 kV

6.4 CONTACT EROSION AND WIPE

Since the contacts are contained inside the interrupter, they remain clean and require no maintenance. However, during high current interruptions, or high numbers of operations, it is possible for a minimal amount of erosion on the contact surfaces. It is also possible for further compaction of the conductor electrodes that has been known to reduce the amount of contact wipe. The VR-Series+ vacuum interrupter assembly incorporates both the original vacuum interrupter erosion indicator and the contact-spring wipe into one all-encompassing indicator. The adequacy of the remaining contact erosion and wipe can easily be determined by observing the vacuum interrupter side of the operating rod assembly on a closed circuit breaker. The procedure to determine the adequacy of the "T" cutout on the vacuum interrupter assembly is depicted in Figures 6.1 and 6.2. Some configurations may require the use of a small mirror and

flashlight to clearly see the "T" cutout. As long as any part of the "T" cutout is visible on each pole unit, the contact surfaces and spring pressure are adequate for the circuit breaker to interrupt its full rated nameplate short circuit and carry continuous current without over-heating. If the wipe is inadequate (no part of the "T" cutout is visible) then the vacuum interrupter assembly must be replaced. Field adjustment is not possible.

⚠ WARNING

FAILURE TO REPLACE A VACUUM INTERRUPTER ASSEMBLY WHEN THE "T" CUTOUT IS NOT VISIBLE WILL CAUSE THE CIRCUIT BREAKER TO FAIL TO INTERRUPT AND THEREBY CAUSE PROPERTY DAMAGE OR PERSONAL INJURY.

Figure 6.1. The Arrow Shows The "T" Contact Wipe Indicator - (If the "T" or any portion of its visible as shown with the circuit breaker closed, the wipe is satisfactory)(See next figure for graphic of all possibilities)

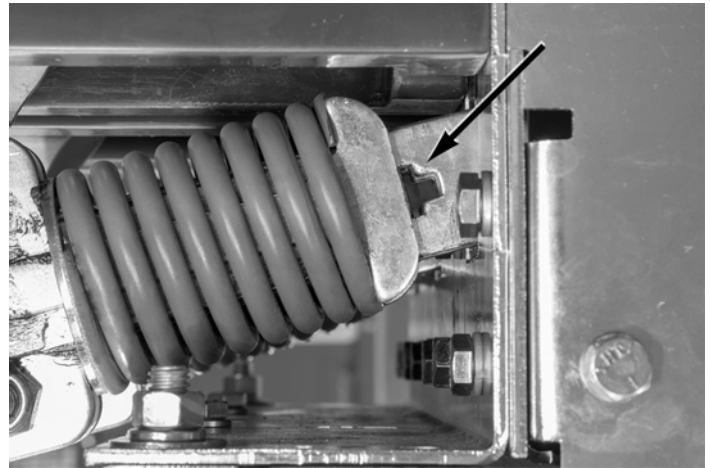
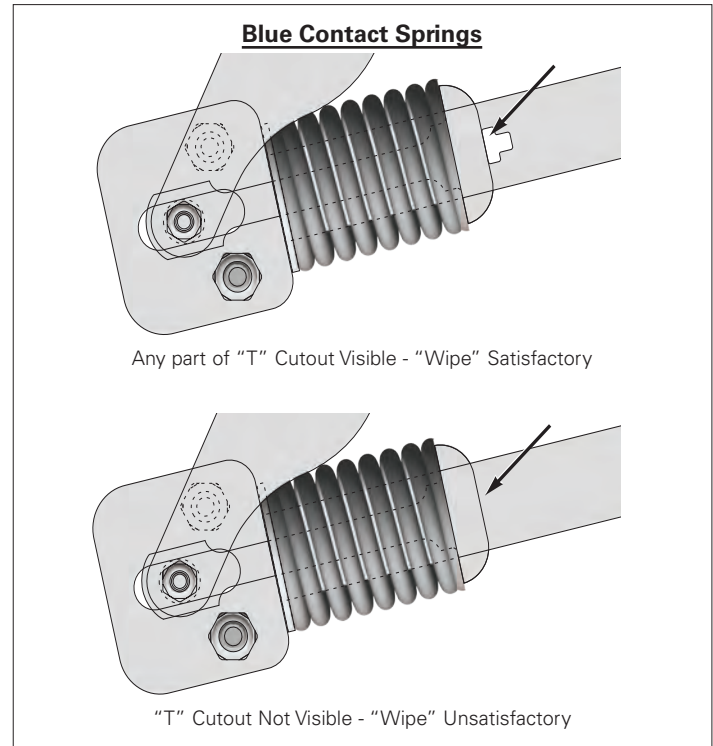

Figure 6.2. Wipe Indication Procedure (Performed Only With Circuit Breaker Closed)



6.5 INSULATION

In VR-Series+ circuit breakers, insulation maintenance primarily consists of keeping all insulating surfaces clean. This can be done by wiping off all insulating surfaces with a dry lint free cloth or dry paper towel. In case there is any tightly adhering dirt that will not come off by wiping, it can be removed with a mild solvent or distilled water. But be sure that the surfaces are dry before placing the circuit breaker in service. If a solvent is required to cut dirt, use Isopropyl Alcohol or commercial equivalent. Secondary control wiring requires inspection for tightness of all connections and damage to insulation.

6.6 INSULATION INTEGRITY CHECK

PRIMARY CIRCUIT:

The integrity of primary insulation may be checked by the ac high potential test. The test voltage depends upon the maximum rated voltage of the circuit breaker. For the circuit breakers rated 4.76 kV the test voltage is 15 kV RMS, 60 Hz. Conduct the test as follows:

Close the circuit breaker. Connect the high potential lead of the test machine to one of the poles of the circuit breaker. Connect the remaining poles and circuit breaker frame to ground. Start the machine with output potential at zero and increase to the test voltage. Maintain the test voltage for one minute. Repeat for the remaining poles. Successful withstand indicates satisfactory insulation strength of the primary circuit.

Open the circuit breaker. Connect the high potential lead of the test machine to one of the terminals of the circuit breaker. Connect the remaining terminals and circuit breaker frame to ground. Start the machine with output potential at zero and increase to the test voltage. Maintain the test voltage for one minute. Repeat for the remaining poles. Successful withstand indicates satisfactory insulation strength of the primary circuit.

SECONDARY CIRCUIT:

Isolate the motor by disconnecting the two motor leads from the terminal block. Connect all points of the secondary disconnect contact pins with a shooting wire. Connect this wire to the high potential lead of the test machine. Ground the circuit breaker frame. Starting with zero, increase the voltage to 1125 RMS, 60 Hz. Maintain the voltage for one minute. Successful withstand indicates satisfactory insulation strength of the secondary control circuit. Remove the shooting wire and reconnect the motor leads.

6.7 PRIMARY CIRCUIT RESISTANCE CHECK

The main contacts of the VR-Series+ circuit breaker are inside the vacuum chamber where they remain clean and require no maintenance at any time.

The dc electrical resistance of the primary circuit may be calculated by measuring the voltage drop across the circuit. This test should be performed with a low voltage, direct current (dc) power supply capable of delivering no less 100A dc.

- To check the primary circuit resistance:
- Remove the circuit breaker from the circuit breaker compartment
- Close the circuit breaker
- Pass at least 100A dc from terminal to terminal of each pole unit in the closed position
- Measure the voltage drop across the terminals.

The resistance can be calculated from Ohm's Law and is expressed in micro-ohms. Repeat for the remaining two poles.

The resistance should not exceed the factory test levels more than 200% as stated in IEEE C37.09. Factory test levels are recorded on the circuit breaker test form, which is included with the circuit breaker. If measurements exceed 200%, contact the manufacturer.

Resistance conversion for Temperature

$$R_{\text{conversion}} = R_{\text{Factory}} (1 + (T_{\text{Field}} - T_{\text{Factory}}) \rho)$$

$R_{\text{conversion}}$ = Resistance correction for temperature based from the factory resistance measurement.

R_{Factory} = Resistance measurement from the factory.

T_{Field} = Temperature measurement in the field.

T_{Factory} = Temperature measurement from the factory.

ρ = Copper resistivity temperature coefficient.

ρ = 0.0039 Copper Resistivity Temperature Coefficient / Deg C

ρ = 0.002167 Copper Resistivity Temperature Coefficient / Deg F

6.8 VR-SERIES+ CIRCUIT BREAKER ELEMENT MECHANISM CHECK

Make a careful visual inspection of the mechanism for any loose parts such as bolts, nuts, pins, rings, etc. Check for excessive wear or damage to the circuit breaker components. Operate the circuit breaker several times manually and electrically. Check the closing and opening times to verify that they are in accordance with the limits in Table 4.

6.8.1 CLOSURE™ TEST

Introduction: The CloSure™ Test is a simple yet extremely effective means to determine and monitor the ability of the mechanism to close the circuit breaker contacts fully. It provides a quantitative measure of the extra energy available in terms of over travel in inches to close the circuit breaker contacts to their full extent. It may be used periodically to monitor the health of the mechanism.

General Information: The CloSure™ Test can be performed on all VR-Series+ circuit breakers. (Refer to Table 6.2.) If the CloSure™ travel obtained is as specified, the mechanism performance is satisfactory. If the CloSure™ travel does not conform as shown in Figure 6.14, contact Eaton's Electrical Services & Systems for further information. (See Step 13).

⚠ DANGER

DO NOT ATTEMPT TO INSTALL OR PERFORM MAINTENANCE OR TESTS ON THE EQUIPMENT WHILE IT IS ENERGIZED. NEVER PUT YOUR HANDS NEAR THE MECHANISM WHEN THE CIRCUIT BREAKER IS IN THE CHARGED OR CLOSED POSITION. DEATH OR SEVERE PERSONAL INJURY CAN RESULT FROM CONTACT WITH ENERGIZED EQUIPMENT. ALWAYS VERIFY THAT NO VOLTAGE IS PRESENT BEFORE PROCEEDING WITH THE TASK, AND ALWAYS FOLLOW GENERALLY ACCEPTED SAFETY PROCEDURES.

Safety Precautions: Read and understand these instructions before attempting any maintenance, repair or testing on the circuit breaker. The user is cautioned to observe all recommendations, warnings and cautions relating to the safety of personnel and equipment.

Note: Hearing protection is recommended as the circuit breaker is opened and closed.

The recommendations and information contained herein are based on Eaton experience and judgment, but should not be considered to be all-inclusive or covering every application or circumstance which may arise. If further information is required, you should consult Eaton's Electrical Services & Systems.

Testing Procedures: Assuming that the circuit breaker is safely removed from the circuit breaker compartment enclosure and positioned in an area outside the arc fault boundary, follow this procedure to perform the CloSure™ test. For further instructions on removal of the circuit breaker from the circuit breaker compartment, refer to the appropriate section of this manual.

MA-VR+ VR-Series+ Replacement Circuit Breaker

Figure 6.3. Status Indicators (“A” shows the spring indication and “B” shows the contact status indication.)

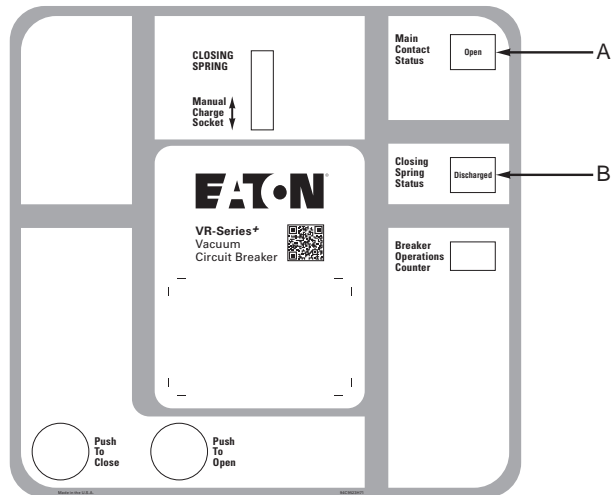

- Step 1** - On the front cover, identify the status indicators. Confirm the closing spring status indicates ‘Discharged’ and the main contact indicator shows ‘Open’ (Figure 6.3).
- Step 2** - Remove the circuit breaker front cover. Be sure to save the original fasteners for reassembly.
- Step 3** - Charge the circuit breaker, close the circuit breaker, then open the circuit breaker. Alternately depress the Open and Close clappers a few times to ensure the circuit breaker is completely discharged.
- Step 4** - Cut a piece of one inch wide drafting / masking tape approximately 8 to 10 inches long.
- Step 5** - Clean the far left cam with a mild solvent such as alcohol. Place the tape around the cam starting from the bottom up. Make certain that the tape adheres well to the cam surface. (Figure 6.4).

Figure 6.4. Wrapping Tape Around Cam

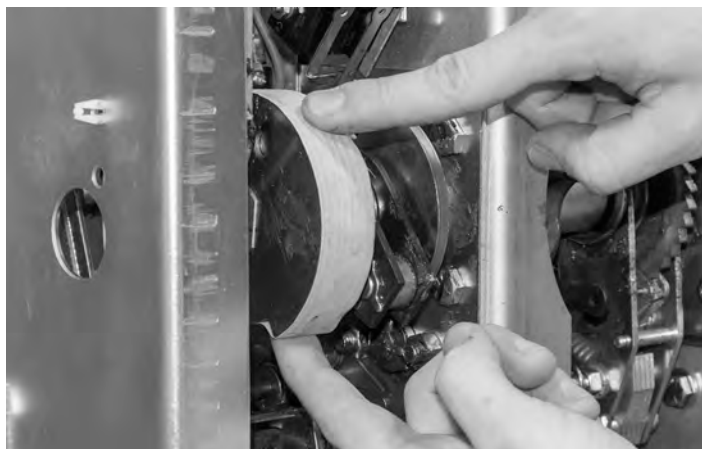

- Step 6** - Mount the transparent CloSure™ Test Tool (Figure 6.5.b) with two bolts and washers. Refer to Figure 6.5.a and Table 6.1 for approximate mounting holes. Hand tighten the bolts.
- Step 7** - Using a red Sanford® Sharpie® fine point permanent marker (or equivalent), place the marker tip in the proper hole (“C”) located over the cam and make a heavy mark on the tape by moving the marker as described in Figures 6.7 and 6.11. Remove the marker from the hole.
- Step 8** - Charge the closing springs with the maintenance tool (Charging handle). Continue charging the closing springs until a “click” is heard and the status indicator shows ‘Charged’ (Figure 6.6).

Figure 6.5.a. Attaching CloSure™ Test Tool

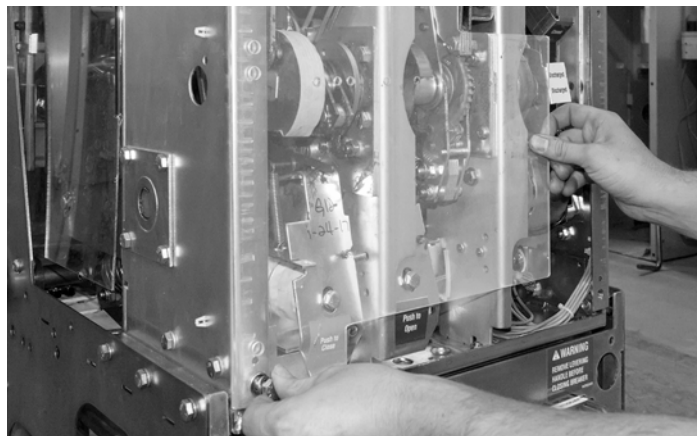

Figure 6.5.b. Front View of CloSure™ Tool Showing Mounting / Testing Hole Locations (6352C49H01)

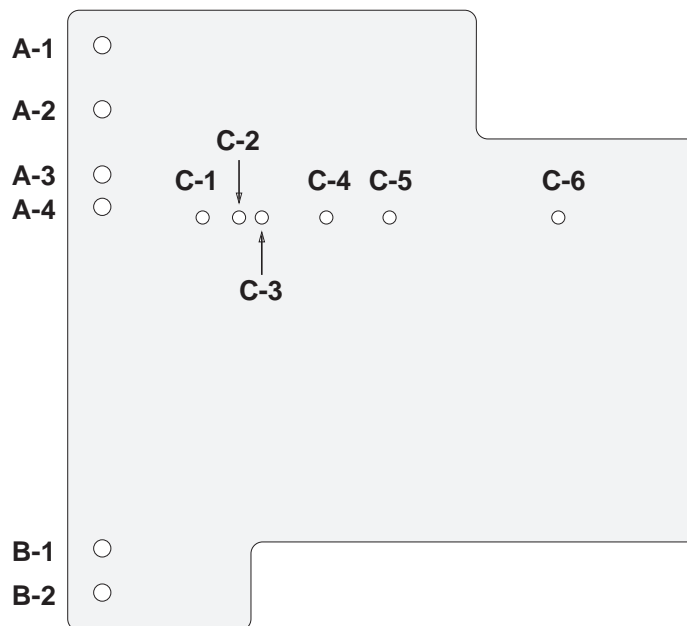

Table 6.2. CloSure™ Tool Mounting / Testing Locations by Circuit Breaker Type

CIRCUIT BREAKER DESIGNATION	APPROXIMATE MECHANISM CHASSIS WIDTH (INCH)	LOWER MOUNTING HOLE	LOWER MOUNTING HOLE	MARKER PLACEMENT HOLE
VR-Series+	18	A1	B2	C1

- Step 9** - Place the marker back in the hole. While holding the marker tip against the tape, close the circuit breaker (Figure 6.8). Remove the marker from the hole.
- Step 10** - While closely observing the pole shaft at the left side of the circuit breaker (Figure 6.9), recharge the closing springs with the maintenance tool. As the circuit breaker is recharged, there should be no movement of the pole shaft. If there is movement of the pole shaft while recharging, this indicates a problem with the circuit breaker - stop the test and consult the factory.
- Step 11** - Open the circuit breaker, then close it, then reopen it. Verify that the mark made in Step 7 is aligned with the pen opening. If it is not aligned, this indicates a problem with the circuit breaker - stop the test and consult the factory.

Figure 6.5.c. Typical Circuit Breaker Front View with CloSure™ Tool Attached (Approximate Mechanism Chassis Width)

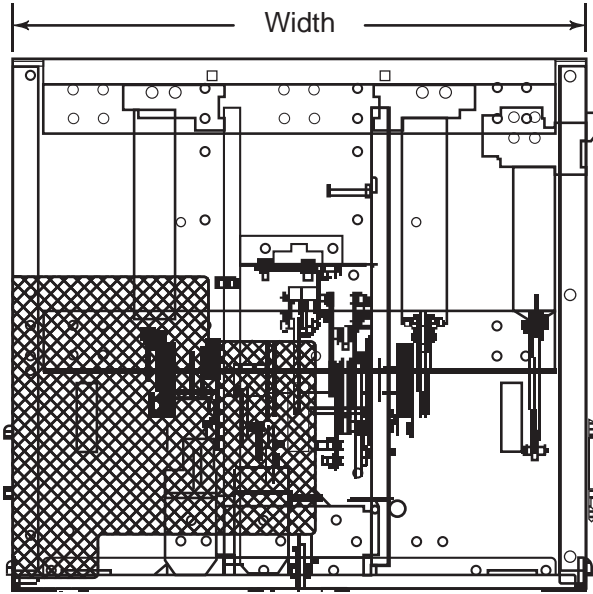

Figure 6.6. Manually Charging Closing Springs

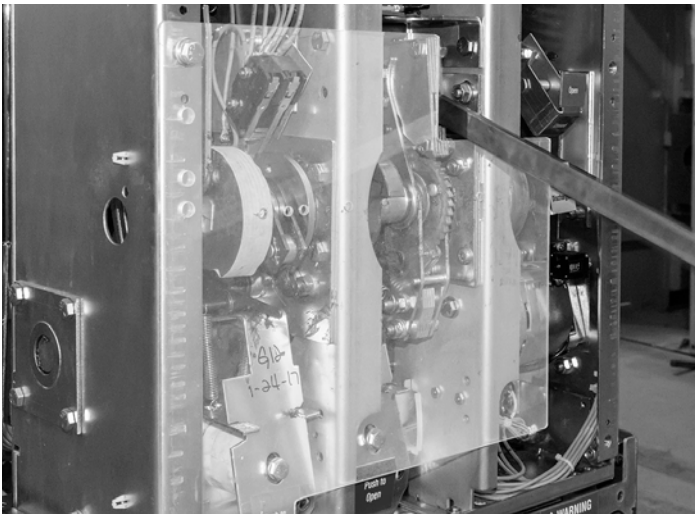
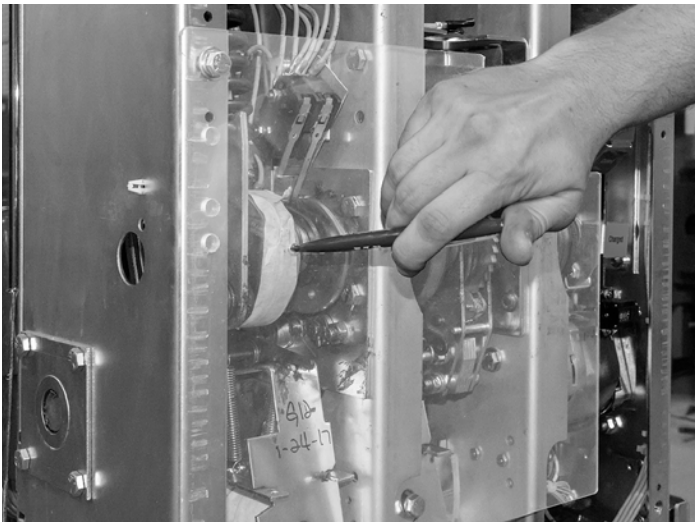

Figure 6.7. Make a Clear and Heavy Mark



Step 12 - Inspect the circuit breaker to assure it is in the open position and the closing springs are discharged. Alternately depress the Open and Close clappers a few times to ensure the circuit breaker is completely discharged. Remove the transparent CloSure™ Tool.

Step 13 - Remove the tape from the cam and place it on a sheet of paper that can be kept as a record of the test. Record the date of the test, person conducting the test, circuit breaker serial number, and the operations counter on the tape or paper (Figures 6.12 and 6.13).

Step 14 - Evaluate the CloSure™ performance by comparing the test tape with the illustration in Figure 6.14. Measure the over travel "X". If "X" is greater than or equal to 0.6", the circuit breaker performance is satisfactory. If "X" is less than 0.6", this indicates a problem with the circuit breaker - consult the Power Breaker Center for technical support.

Step 15 - Reassemble the front cover onto the circuit breaker. Return the circuit breaker to its original configuration and setup.

Figure 6.8. With Marker in Hole "C", While Closing Circuit Breaker



Figure 6.9. Pole Shaft Located On Left Side Of Circuit Breaker



Figure 6.10. Move the Sharpie® 15° Left and Right

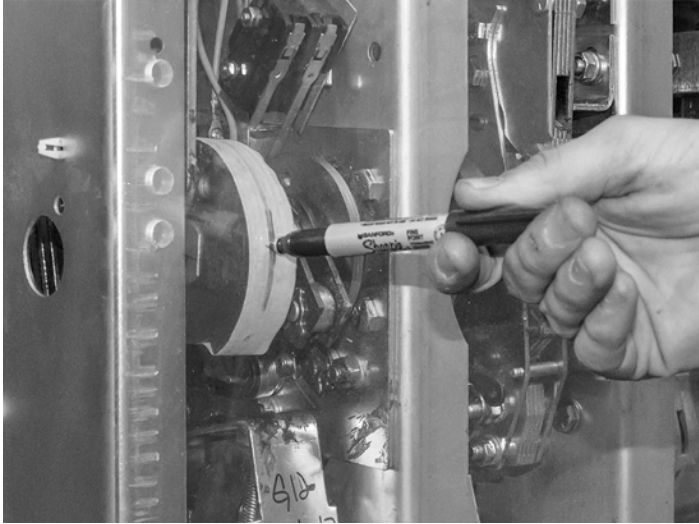

Figure 6.13. Determining the Distance Traveled



Figure 6.11. Top view of Cam and Marker Interface

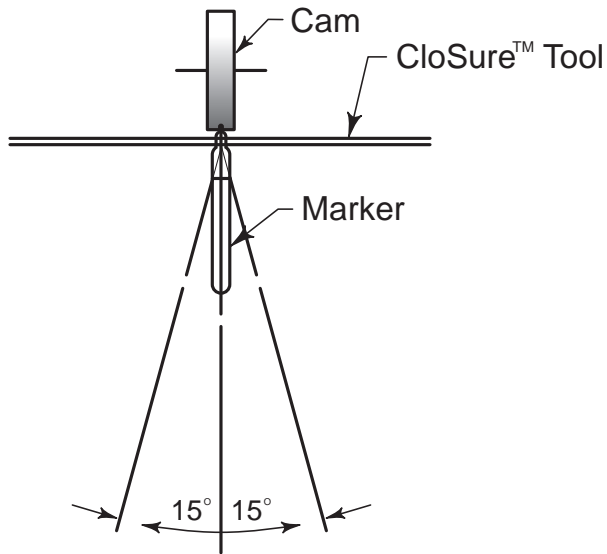
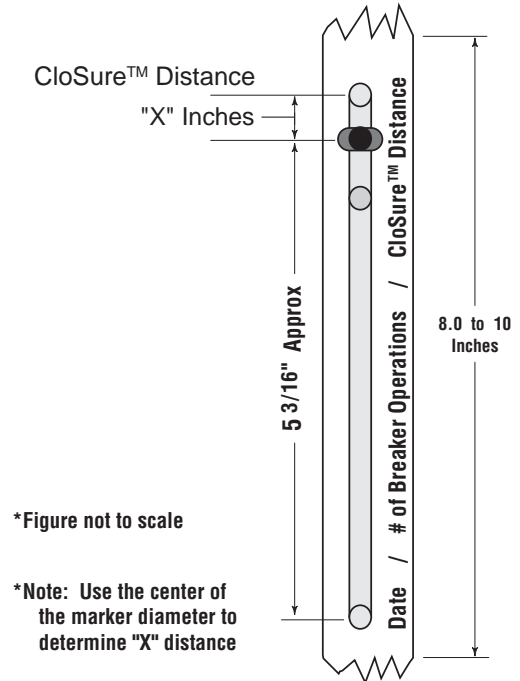

Figure 6.12. Evaluate the CloSure™ Performance



Figure 6.14. Illustrative Testing Tape Sample



6.9 MAINTENANCE RECOMMENDATION

The VR-Series+ circuit breaker is lubricated during assembly with a long lasting synthetic lubricant. When applied in "usual service conditions" as defined by IEEE C37.04-1999, the VR-Series+ circuit breaker element requires maintenance only once every ten years or ten thousand operations, which ever comes first.

After a ten year service interval or when ten thousand operations have been reached, contact your local Eaton representative to arrange for factory recertification.

During the ten year service interval, no supplemental lubrication with light machine oil is recommended. Machine oil may be incompatible with the advanced lubricant in the VR-Series+ vacuum replacement circuit breaker and will damage the components of the stored energy mechanism.

MA-VR+ VR-Series+ Replacement Circuit Breaker

Table 6.3. Troubleshooting Chart

SYMPTOM	INSPECTION AREA	PROBABLE DEFECTS
FAILS TO CLOSE		
Closing Springs Not Charged	Control Circuit	<ul style="list-style-type: none"> Control Power (Fuse blown or switch off) Secondary Disconnect Contacts Motor Cut-off Switch (Poor or burned contacts. Lever not operational.) Terminals And Connectors (Poor or burned contacts) Motor (Brushes worn or commutator segment open)
	Mechanism	<ul style="list-style-type: none"> Pawls (Slipping or broken) Ratchet Wheel (Teeth worn or broken) Cam Shaft Assembly (Sluggish or jammed) Oscillator (Reset Spring off or broken)
Closing Springs Not Charged Circuit Breaker Does Not Close	Control Circuit (Close Coil does not pick up)	<ul style="list-style-type: none"> Control Power (Fuse blown or switch off) Secondary Disconnect Contacts Anti Pump Relay (Y Relay N.C. contact open or burned or relay picks up) Close Coil (Open or burned) Latch Check Switch (Contact open - Bad switch or trip bar not reset) Auxiliary Switch (B Contact open or burned) Motor Cut-Off (Contacts open or burned) Trip Coil Assembly (Clapper fails to reset)
	Closing sound but no close	<ul style="list-style-type: none"> Pole Shaft (Not open fully) Trip Latch Reset Spring (Damaged or missing) Trip Bar-D Shaft (Fail to remain reset) Trip Latch-Hatchet (Fails to remain reset) Trip Floor Tripper (Fails to remain reset) Close Latch (Binding) Close Latch Roller (Binding) Trip Circuit Energized
UNDESIRABLY CLOSES		
	Control Circuit	<ul style="list-style-type: none"> Close Circuit (CS/C getting shorted)
	Mechanism	<ul style="list-style-type: none"> Close Release Latch (Fails to reset) Close Floor Tripper (Fails to reset)
FAILS TO CLOSE		
No Trip Sound	Control Circuit	<ul style="list-style-type: none"> Control Power (Fuse blown or switch off) Secondary Disconnect Contacts Auxiliary Switch (A contact not making poor or burned) Trip Coil (Burned or open) Terminals and connections (Poor or burned or open) Trip Clapper (Jammed)
	Trip Mechanism	
Trip Sound But No Trip	Trip Mechanism	<ul style="list-style-type: none"> Trip Bar, Trip Latch (Jammed) Pole Shaft (Jammed) Operating Rod Assembly (Broken or pins out)
	Vacuum Interrupter (One Or More Welded)	
UNDESIRABLY TRIPS		
	Control Circuit	<ul style="list-style-type: none"> Control power (CS/T Switch, remains made)
	Mechanism	<ul style="list-style-type: none"> Trip Coil Clapper (Not resetting) Trip Bar or Trip Latch (Poor engagement of mating or worm surfaces) Trip Bar Reset Sprint (Loss of torque)

SECTION 7: REPLACEMENT PARTS











7.1 GENERAL

In order to minimize production downtime, it is recommended that an adequate quantity of spare parts be carried in stock. The quantity will vary from customer to customer, depending upon the service severity and continuity requirements. Each customer should develop his own level based on operating experience. However, when establishing a new operating record, it is a good practice to stock one set of control components for every six circuit breakers of the same control voltage. This quantity should be adjusted with time and frequency of operation of the circuit breakers.

7.2 ORDERING INSTRUCTIONS

- The style numbers in Table 7.1 should be sufficient to purchase control components for most applications. Some circuit breakers have special control schemes. Supply complete nameplate information for verification or if additional components are needed.
- Specify the method of shipping desired.
- Send all orders or correspondence to the nearest Eaton sales office or contact the PBC direct at 1-877-276-9379.
- Include negotiation number with order when applicable.

Table 7.1 Common Replacement Parts - Descriptions and Style Numbers

1.	ANTI-PUMP (Y) RELAY	(48Vdc) (125Vdc) (250Vdc) (120Vac) (240Vac)	94C9525H01 94C9525H02 94C9525H03 94C9525H04 94C9525H05	6.	POSITION SWITCH	Circuit Breaker Position Switch PS2	94C9525H07
							
2.	RECTIFIER	Rectifier	94C9525G09	7.	LATCH CHECK SWITCH	Latch Check Switch (LC)	94C9525H08
							
3.	SPRING CHARGING MOTOR	(48Vdc) (125Vdc) (250Vdc / 240Vac)	94C9525G10 94C9525G11 94C9525G12	8.	MOTOR CUTOFF SWITCHES	(LS)	94C9525G15
							
4.	AUXILIARY SWITCH	Circuit Breaker Auxiliary Switch	94C9525G13	9.	SPRING RELEASE COILS / SHUNT TRIPS	24Vdc 48Vdc 125Vdc / 120Vac 250Vdc / 240Vac	94C9525G16 94C9525G17 94C9525G18 94C9525G19
							
5.	POSITION SWITCH	Circuit Breaker Position Switch PS1	94C9525H06	10.	CONTROL COMPONENTS KIT	48Vdc 125Vdc 250Vdc 120Vac-C/M 48Vdc-T 240Vac-C/M 48Vdc-T 120Vac-C/M 120Vac-CT 240Vac-C/M 240Vac-CT	94C9525G01 94C9525G02 94C9525G03 94C9525G04 94C9525G05 94C9525G06 94C9525G07
							

APPENDIX A: LEVERING HANDLE RACKING

A.1 LEVERING HANDLE RACKING SYSTEM

⚠ WARNING

DO NOT USE ANY TOOL TO LEVER THE CIRCUIT BREAKER TO OR FROM THE CONNECTED POSITION OTHER THAN THE LEVERING HANDLE.

A.1.1 INSERTION PROCEDURE

a. Place the circuit breaker in the withdrawn position (Figure 4.3). The levering handle is not required for this position and the levering system interlocks are not automatic outside the cell. The circuit breaker can be operated in this position and extreme care should be exercised to avoid inadvertent operation and possible injury or equipment damage.

⚠ WARNING

THE CIRCUIT BREAKER CAN BE OPERATED IN THE WITHDRAWN POSITION AND EXTREME CARE SHOULD BE EXERCISED TO AVOID INADVERTENT OPERATION AND POSSIBLE INJURY OR EQUIPMENT DAMAGE.

- b. From the withdrawn position, align the guide bar of the circuit breaker with the guide rails of the cell.
- c. Check that the closing spring status indicator reads "DISCHARGED" and that the main contact status indicator reads "OPEN". Manually trip, close, and trip the circuit breaker as needed to obtain this status.
- d. Push the circuit breaker into the cell until all the wheels are on the floor and the spring discharge linkage has not cycled. No mechanical stop will be reached. In this position the circuit breaker can still be operated because there is no interface of the cell floor and circuit breaker interlocks. No cell labeling is provided to verify this position.
- e. Push the circuit breaker further into the cell. The pressing of the interlock pedal will make this operation easier but due to the cell design, pressing of the pedal is not required at this stage.
- f. Once movement has started, the interlock pedal should be released if pressed. An audible click of the interlock pedal engaging the interlock rail will be heard at about 9 inches travel from the withdrawn to the disconnect position. The interlock pedal will travel down at the beginning of movement and rapidly rise a short distance to lock the circuit breaker in the disconnect position at the end of the normal travel from withdrawn to disconnect. The movement of the pedal provides an open signal that remains throughout all intermediate circuit breaker positions and the floor trip will be used during the first 4 inches of inward travel along with a closing signal to discharge the closing springs. The circuit breaker remains tripped until the test position is reached. The disconnect position can be verified by the inability to move the circuit breaker in or out, the interlock pedal has slightly risen, and the cell label "disconnect" is indicated on the right side of the cell. The circuit breaker is still held open with further forward motion halted and rearward motion inhibited by the floor interlock plunger. This is the "disconnect" position and the circuit breaker cannot be operated because of the interface of the interlock plunger and interlock pedal with the circuit breakers trip linkage.
- g. From the disconnect position, depress the interlock pedal and push the circuit breaker another 1.5 inches to reach the test position. The test position can be verified by the inability to move the circuit breaker in or out, the interlock pedal is in the full up position, and the cell label "test" is indicated on the right side of the cell. In the "test" position, the circuit breaker can be operated manually and electrically, thus allowing maintenance tests or checks. The shutter operator will engage the shutter lift pin and begin to raise the shutter in the test position. Although slightly raised, the steel shutters still cover the primary stabs, isolating the circuit breaker from the source. The secondary control block is engaged automatically as the

circuit breaker advances from the disconnect to the test position and remains connected throughout further inward movement. The spring charging motor will begin to run and charge the closing spring as the trip interlock is released. The circuit breaker is now in the "test" position, with control voltage applied, and ready for electrical or manual testing.

⚠ NOTICE

ONCE THE SECONDARY DISCONNECT BLOCK IS ENGAGED IN THE "TEST" POSITION, IT WILL REMAIN CONNECTED THROUGHOUT FURTHER INWARD MOVEMENT AS THE CIRCUIT BREAKER ADVANCES FROM THE "TEST" TO THE "CONNECT" POSITION.

THE SPRING CHARGING MOTOR WILL BEGIN TO RUN, IF THE MOTOR CUT-OFF SWITCH IS IN THE "ON" POSITION, AND CHARGE THE CLOSING SPRING AS THE SECONDARY CONNECTION IS MADE AS LONG AS CONTROL POWER IS AVAILABLE. THE CIRCUIT BREAKER IS NOW IN THE "TEST" POSITION, WITH CONTROL VOLTAGE APPLIED AND READY FOR ELECTRICAL OR MANUAL TESTING.

- h. To advance from the test position, depress the interlock pedal and push the circuit breaker about 7 inches until the cell floor levering angle is visible. During this time, any attempt to mechanically close the circuit breaker will cause a trip-free operation. As you continue to advance the circuit breaker into the cell the primary voltage source shutters will fully open allowing the circuit breaker stabs to engage with the source. To install the circuit breaker in the connected position the levering handle will have to be used. Insure the circuit breaker is open and engage the levering handle with the circuit breaker and floor angle (See Figure A.1).

Figure A.1. Rack-In Position of Levering Handle



i. Lever the circuit breaker into the connect position by shifting the levering handle forward. The closing springs may be in the charged state but the internal PS switch will prevent operation of the close spring release coil (preventing an electrical close).

j. Continue moving the circuit breaker into the cell for about 9 inches of total travel from the test position until a mechanical stop is reached.

This is the fully engaged or connected position. The connect position can be verified by the inability to move the circuit breaker in or out, the interlock pedal is fully up, the trip mechanism and has been released, and the cell label "operate" is indicated on the right side of the cell. The circuit breaker is now ready for service.

⚠ WARNING

DO NOT ATTEMPT TO REMOVE A CLOSED CIRCUIT BREAKER. VERIFY THE CIRCUIT BREAKER IS IN THE OPEN POSITION PRIOR TO PROCEEDING.

A.1.2 REMOVAL PROCEDURE

To remove the circuit breaker from the cell it must be in the open position. Insure the circuit breaker is open and engage the levering handle. The interlock pedal must be depressed which will raise the trip mechanism and trip the circuit breaker. Move the circuit breaker out using the levering handle (Figure A.2) The circuit breaker will start coming out of the cell before the main stabs are disconnected and will be in a non-operable mode. The circuit breaker will go through a trip-free operation if any attempt to close it is made in the intermediate position. The shutters will start to close after the main stabs have cleared, isolating the circuit breaker from its source. Continue removing the circuit breaker until the position indicator on the right side of the cell shows test and the pedal rises to lock the circuit breaker in position. The circuit breaker is in the test position and ready to be operated either electrically or mechanically

Figure A.2. Rack-Out Position of Levering Handle



To remove the circuit breaker to the disconnect position, depress the interlock pedal and pull outward until the disconnect position stop halts outward travel. To further remove the circuit breakers, the interlock pedal must be again depressed. As the circuit breaker travels outward the last 4 inches in the cell, a floor close signal will combine with the trip signal from the interlock pedal to force a trip-free condition. This will cause the charging springs to discharge leaving the circuit breaker in the open position and the closing springs discharged.

Once the circuit breaker is withdrawn past the floor trip activation area, it is in the withdrawn position. The circuit breaker is ready to be removed from the cell if desired.

A.2 RACKING SYSTEM TRIP AND SPRING RELEASE INTERLOCKS

A.2.1 LEVERING HANDLE RACKING

The interlock plunger prevents engaging a closed circuit breaker with energized cell buss work or removing a potentially hazardous circuit breaker from the cell. The foot lever (Interlock Pedal) operates the interlock plunger as well as the trip mechanism. Depressing the lever trips the circuit breaker and raises the plunger sufficiently to release the circuit breaker allowing it to be moved in the cubicle. Reference Table A.1 for interlock adjustment dimensions.

Table A.1. MA-VR Reference Dimensions For Floor Plunger

DIMENSION OF PLUNGER FROM FLOOR	SIGNIFICANCE
1.688	Lower Limit of Free Plunger State, Circuit Breaker Fully Functional
1.813	Upper Limit of Free Plunger, Circuit Breaker Fully Functional
2.000	Lower Limit of Circuit Breaker Becoming Trip-Free
2.062	Upper Limit of Circuit Breaker Becoming Trip-Free
2.062	Lower Limit of Circuit Breaker Tripping Open
2.187	Upper Limit of Circuit Breaker Tripping Open

A.2.2 MA-VR PRIMARY STAB TOLERANCE

Primary Stab Location: +/- 1/8 from nominal vertically and/or horizontally. This measurement must be made with the circuit breaker positioned on a level surface (Due to its unlevel nature, positioning the circuit breaker on a concrete surface is not considered an acceptable level surface.)

APPENDIX B: OPTIONAL SECONDARY CONNECTION BLOCK EXTENSION CABLE

⚠ WARNING

ALL SAFETY CODES, SAFETY STANDARDS AND/OR REGULATIONS MUST BE STRICTLY ADHERED TO.

B.1 INSTALLATION AND REMOVAL

1. De-energize and isolate all control power prior to installing the test jumper. Verify that all control power has been de-energized using appropriate methods.
2. Always install the flat contact end of the test jumper (Figure 3.1.c) to the secondary disconnect on the circuit breaker first.
3. Align the test jumper guide with the guide on the circuit breaker by placing the bends of the test jumper behind the guide of the secondary disconnect on the circuit breaker. (Figures B.1 & B.2)
4. Slide the flat contact end of the test jumper from left to right onto the circuit breaker secondary disconnect. The test jumper will reach an end stop when fully connected. (Figure B.3)
5. Install the spring contact end of the test jumper to the secondary disconnect in the switchgear cubicle.
6. Align the test jumper with the switchgear cubicle secondary disconnect. (Figure B.4)

Figure B.1. Alignment of Test Jumper to Circuit Breaker

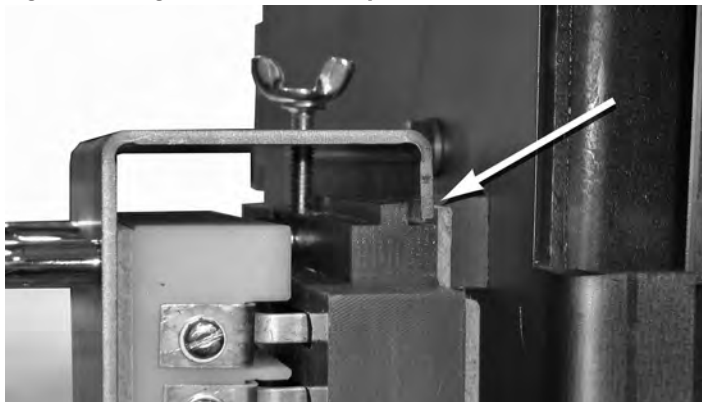
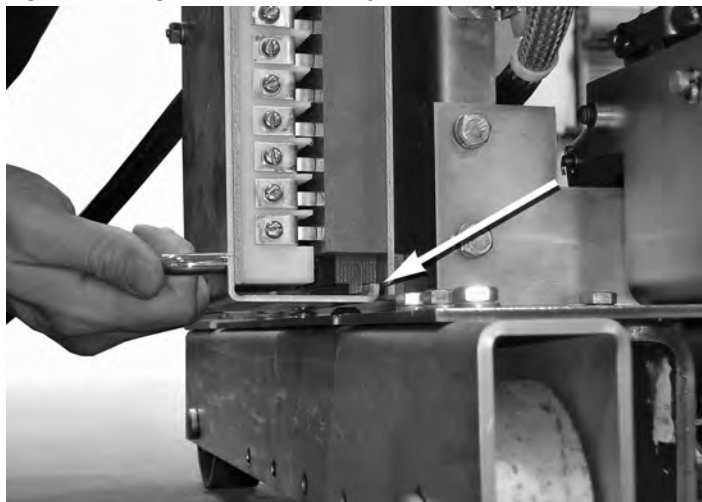

Figure B.2. Alignment of Test Jumper to Circuit Breaker



7. Pull and twist the spring plunger (located on the bottom of the test jumper) 90 degrees to the retracted position. (Figure B.5)
8. Push the spring contact end onto the switchgear cubicle disconnect while retracting the spring plunger (located on the top) (Figure B.6). Then twist the spring plunger (located on the bottom) approximately 90 degrees so that it is released.
9. An audible click will be heard if there is successful engagement of the test jumper to the switchgear cubicle secondary disconnect.
10. Verify the test jumper is installed securely and correctly. (Figure B.7)
11. After successful test jumper installation, connect and energize all control power.
12. The circuit breaker can now operate electrically out of the cell. Extreme care should be exercised to avoid inadvertent operation and possible injury or equipment damage.
13. To remove the test jumper, de-energize and isolate all control power. Verify that all control power has been de-energized using appropriate methods.

Figure B.3. Test Jumper Installed on Circuit Breaker

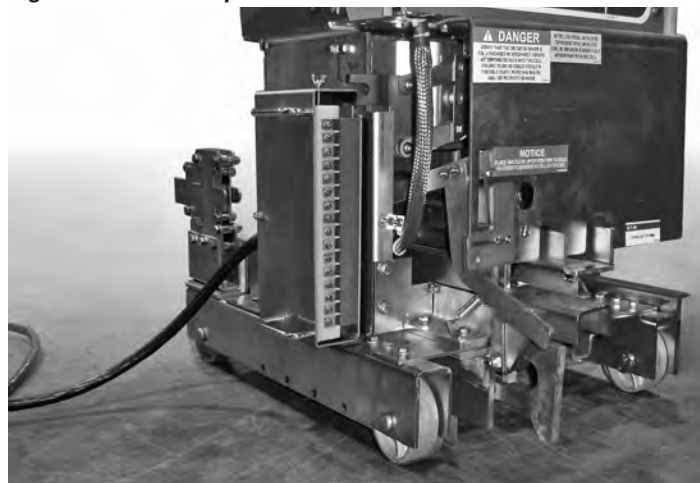

Figure B.4. Test Jumper Installed on Circuit Breaker



Figure B.5. Test Jumper Installed on Circuit Breaker



Figure B.6. Test Jumper Installed on Circuit Breaker

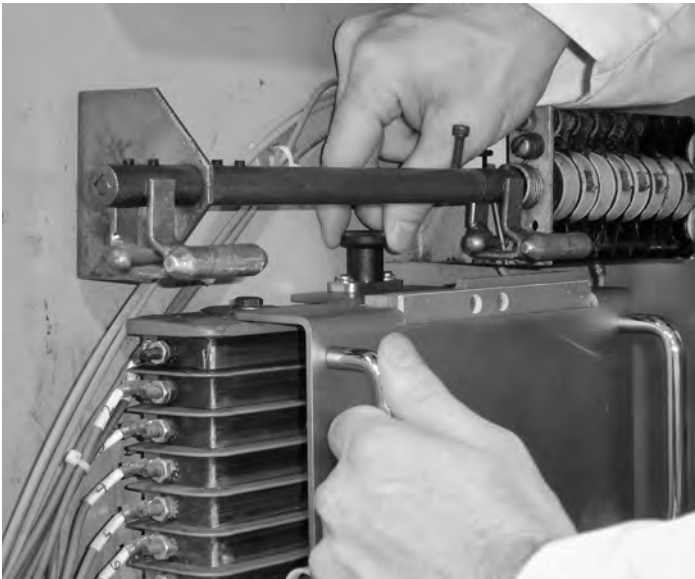

Figure B.7. Test Jumper Installed on Circuit Breaker



Figure B.8. Test Jumper Installed on Circuit Breaker



Figure B.9. Test Jumper Installed on Circuit Breaker



14. Always remove the spring contact end from the switchgear cubicle disconnect first.
15. Simultaneously retract both plungers on the spring contact end of the test jumper. Then the contact end can be removed by pulling outward. (Figure B.8)
16. To remove the flat contact end from the circuit breaker, slide the test jumper from right to left. (Figure B.9)
17. The circuit breaker may have stored energy present. If so, extreme care should be exercised to avoid inadvertent operation and possible injury or equipment damage.

⚠ WARNING

DO NOT PERFORM ELECTRICAL OPERATION CHECKS WITH THE BREAKER IN THE "CONNECT" POSITION BECAUSE OF THE POSSIBILITY OF CONNECTING DE-ENERGIZED LOAD CIRCUITS TO THE ELECTRICAL POWER SOURCE, RESULTING IN DEATH, PERSONAL INJURY OR EQUIPMENT DAMAGE.



Eaton
1000 Eaton Boulevard
Cleveland, OH 44122
United States
Eaton.com

© 2017 Eaton
All Rights Reserved
Printed in USA
Publication No. IB182932EN
September 2017

Eaton is a registered trademark.

All trademarks are property
of their respective owners.