

# AMH-4.76-VR Replacement Circuit Breaker



AMH-4.76-VR 4.76 1200A Shown



*Powering Business Worldwide*

## DISCLAIMER OF WARRANTIES AND LIMITATION OF LIABILITY

The information, recommendations, descriptions and safety notations in this document are based on Eaton's experience and judgment and may not cover all contingencies. If further information is required, an Eaton sales office should be consulted. Sale of the product shown in this literature is subject to the terms and conditions outlined in appropriate Eaton selling policies or other contractual agreement between Eaton and the purchaser.

THERE ARE NO UNDERSTANDINGS, AGREEMENTS, WARRANTIES, EXPRESSED OR IMPLIED, INCLUDING WARRANTIES OF FITNESS FOR A PARTICULAR PURPOSE OR MERCHANTABILITY, OTHER THAN THOSE SPECIFICALLY SET OUT IN ANY EXISTING CONTRACT BETWEEN THE PARTIES. ANY SUCH CONTRACT STATES THE ENTIRE OBLIGATION OF EATON. THE CONTENTS OF THIS DOCUMENT SHALL NOT BECOME PART OF OR MODIFY ANY CONTRACT BETWEEN THE PARTIES.

In no event will Eaton be responsible to the purchaser or user in contract, in tort (including negligence), strict liability or other-wise for any special, indirect, incidental or consequential damage or loss whatsoever, including but not limited to damage or loss of use of equipment, plant or power system, cost of capital, loss of power, additional expenses in the use of existing power facilities, or claims against the purchaser or user by its customers resulting from the use of the information, recommendations and descriptions contained herein. The information contained in this manual is subject to change without notice.

---

### **WARNING**

---

**IMPROPERLY INSTALLING OR MAINTAINING THESE PRODUCTS CAN RESULT IN DEATH, SERIOUS PERSONAL INJURY OR PROPERTY DAMAGE.**

---

**READ AND UNDERSTAND THESE INSTRUCTIONS BEFORE ATTEMPTING ANY UNPACKING, ASSEMBLY, OPERATION OR MAINTENANCE OF THE CIRCUIT BREAKERS.**

---

**INSTALLATION OR MAINTENANCE SHOULD BE ATTEMPTED ONLY BY QUALIFIED PERSONNEL. THIS INSTRUCTION BOOK SHOULD NOT BE CONSIDERED ALL INCLUSIVE REGARDING INSTALLATION OR MAINTENANCE PROCEDURES. IF FURTHER INFORMATION IS REQUIRED, YOU SHOULD CONSULT EATON'S ELECTRICAL SERVICES & SYSTEMS.**

---

**THE CIRCUIT BREAKERS DESCRIBED IN THIS BOOK ARE DESIGNED AND TESTED TO OPERATE WITHIN THEIR NAMEPLATE RATINGS. OPERATION OUTSIDE OF THESE RATINGS MAY CAUSE THE EQUIPMENT TO FAIL, RESULTING IN DEATH, BODILY INJURY AND PROPERTY DAMAGE.**

---

**ALL SAFETY CODES, SAFETY STANDARDS AND/OR REGULATIONS AS THEY MAY BE APPLIED TO THIS TYPE OF EQUIPMENT MUST BE STRICTLY ADHERED TO.**

---

**THESE VACUUM REPLACEMENT CIRCUIT BREAKERS ARE DESIGNED TO BE INSTALLED PURSUANT TO THE AMERICAN NATIONAL STANDARDS INSTITUTE (ANSI). SERIOUS INJURY, INCLUDING DEATH, CAN RESULT FROM FAILURE TO FOLLOW THE PROCEDURES OUTLINED IN THIS MANUAL.**

---

This product was manufactured by Eaton at the Power Breaker Center (PBC): 310 Maxwell Avenue, Greenwood, SC 29646.

All possible contingencies which may arise during installation, operation or maintenance, and all details and variations of this equipment do not purport to be covered by these instructions. If further information is desired by purchaser regarding his particular installation, operation or maintenance of particular equipment, contact an Eaton representative.

**Table of Contents**

<b>SECTION 1: INTRODUCTION</b>	<b>4</b>	<b>SECTION 5: INSPECTION &amp; INSTALLATION</b>	<b>19</b>
1.1 VISUAL INSTRUCTION BOOKLET ESSENTIALS	4	5.1 EXAMINATION FOR DAMAGE	19
1.2 QUICK RESPONSE CODE	4	5.1.1 NAMEPLATE VERIFICATION	19
1.3 AVAILABLE AMH-4.76-VR CIRCUIT BREAKERS	4	5.2 SURE CLOSE MECHANISM ADJUSTMENT	19
<b>SECTION 2: SAFE PRACTICES</b>	<b>6</b>	5.3 MANUAL OPERATION CHECK	20
<b>SECTION 3: RECEIVING, HANDLING, AND STORAGE</b>	<b>7</b>	5.4 VACUUM INTERRUPTER INTEGRITY	20
3.1 RECEIVING	7	5.5 LOW FREQUENCY WITHSTAND TEST (INSULATION CHECK)	20
3.2 HANDLING	7	5.6 CONTACT EROSION AND WIPE	20
3.3 STORAGE	8	5.7 PRIMARY CIRCUIT RESISTANCE	20
3.4 AMH-4.76-VR APPROXIMATE WEIGHTS	8	5.8 ELECTRICAL OPERATIONS CHECK	20
<b>SECTION 4: DESCRIPTION AND OPERATION</b>	<b>11</b>	5.9 DESCRIPTION OF OPERATIONAL POSITIONS	21
4.1 VACUUM INTERRUPTER	11	5.10 INSERTION PROCEDURE	21
4.1.1 THE INTERRUPTER ASSEMBLY	11	5.11 REMOVAL PROCEDURE	22
4.1.2 CONTACT EROSION INDICATOR	11	<b>SECTION 6: INSPECTION &amp; MAINTENANCE</b>	<b>23</b>
4.1.3 CONTACT WIPE AND STROKE	12	6.1 INSPECTION FREQUENCY	23
4.2 PHASE BARRIERS	12	6.2 INSPECTION AND MAINTENANCE PROCEDURES	23
4.3 BUSHINGS AND DISCONNECTING CONTACT ASSEMBLIES	12	6.3 VACUUM INTERRUPTER INTEGRITY TEST	24
4.4 STORED ENERGY MECHANISM	12	6.4 CONTACT EROSION AND WIPE	24
4.4.1 CLOSING SPRING CHARGING	12	6.5 INSULATION	25
4.4.2 CLOSING OPERATION	13	6.6 INSULATION INTEGRITY CHECK	25
4.4.3 TRIPPING OPERATION	13	6.7 PRIMARY CIRCUIT RESISTANCE CHECK	26
4.4.4 TRIP-FREE OPERATION	13	6.8 MECHANISM CHECK	26
4.5 CONTROL SCHEMES	13	6.8.1 CLOSURE™ TEST	26
4.5.1 TIMING	13	6.9 LUBRICATION	29
4.6 SECONDARY CONNECTION BLOCK	13	<b>SECTION 7: REPLACEMENT PARTS</b>	<b>31</b>
4.7 INTERLOCKS	13	7.1 GENERAL	31
4.7.1 ANTI-CLOSE INTERLOCK	13	7.2 ORDERING INSTRUCTIONS	31
4.7.2 RACKING SYSTEM TRIP AND SPRING RELEASE INTERLOCKS	13		
4.8 MISCELLANEOUS ITEMS	15		
4.8.1 MOC OPERATOR	15		
4.8.2 OPERATIONS COUNTER	15		

## SECTION 1: INTRODUCTION

The purpose of this book is to provide instructions for receiving and handling, storage, installation, operation and maintenance of the General Electric type AMH-4.76 VR-Series circuit breaker. The Vacuum Replacement Circuit Breakers (also referred to as VR-Series) are designed to be used in existing AMH-4.76 metal-clad switchgear and provide equal or superior electrical and mechanical performance as compared to the design ratings of the original circuit breaker. VR-Series Circuit Breakers provide reliable control, protection and performance, with ease of handling and maintenance. Like ratings are interchangeable with each other.

This book is intended to be used in conjunction with the technical information provided with the original equipment order which includes, but is not limited to electrical control schematics and wiring diagrams, outline diagrams, installation plans, and procedures for installation and maintenance of accessory items.

Satisfactory performance is dependant upon proper application, correct installation, and adequate maintenance. It is strongly recommended that this instruction book be carefully read and followed in order to realize optimum performance and long useful life of the circuit breaker.

### 1.1 VISUAL INSTRUCTION BOOKLET ESSENTIALS

Eaton provides additional documentation designed to enhance the technical information provided in this instruction booklet for the VR-Series circuit breakers. The Visual Instruction Booklet Essentials (VIBE) is a digital supplemental booklet featuring user interactive content and informative videos intended to assist with the maintenance of the VR-Series circuit breaker. The VIBE document is available for immediate download at [www.eaton.com/VR-Series](http://www.eaton.com/VR-Series).

### 1.2 QUICK RESPONSE CODE

VR-Series circuit breakers have a quick response code (QR Code) on the escutcheon of the circuit breaker cover. This QR Code is a matrix barcode that provides direct access to download VR-Series specific documentation, such as product instruction booklets and the VIBE documentation. See Figure 1.1 for the featured VR-Series QR Code.

**Note:** A smart phone with an adequate QR Code Scanner application must be used. Downloading content may incur data charges from the mobile service provider.

Figure 1.1. Quick Response Code

VR-Series QR Code

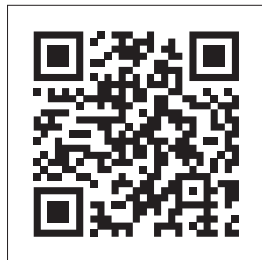

## ⚠ WARNING

**SATISFACTORY PERFORMANCE OF THESE BREAKERS IS CONTINGENT UPON PROPER APPLICATION, CORRECT INSTALLATION AND ADEQUATE MAINTENANCE. THIS INSTRUCTION BOOK MUST BE CAREFULLY READ AND FOLLOWED IN ORDER TO OBTAIN OPTIMUM PERFORMANCE FOR LONG USEFUL LIFE OF THE CIRCUIT BREAKERS. IT IS FURTHER RECOMMENDED THAT THE INSTALLATION BE PERFORMED BY A EATON CORPORATION TRAINED ENGINEER OR TECHNICIAN.**

**VR-SERIES BREAKERS ARE PROTECTIVE DEVICES, AS SUCH, THEY ARE MAXIMUM RATED DEVICES. THEREFORE, THEY SHOULD NOT UNDER ANY CIRCUMSTANCE BE APPLIED OUTSIDE THEIR NAMEPLATE RATINGS.**

**ALL POSSIBLE CONTINGENCIES WHICH MIGHT ARISE DURING INSTALLATION, OPERATION, OR MAINTENANCE, AND ALL DETAILS AND VARIATIONS OF THIS EQUIPMENT ARE NOT COVERED BY THESE INSTRUCTIONS. IF FURTHER INFORMATION IS DESIRED BY THE PURCHASER REGARDING A PARTICULAR INSTALLATION, OPERATION, OR MAINTENANCE OF THIS EQUIPMENT, THE LOCAL EATON REPRESENTATIVE SHOULD BE CONTACTED.**

### 1.3 AVAILABLE AMH-4.76-VR CIRCUIT BREAKERS

Refer to Table 1.

Table 1. AMH-4.76-VR Availability and Interchangeability

Breaker Type	Nominal Voltage Class (kV)	Existing Breaker MVA Rating	Existing Breaker Rated Continuous Current at 60 Hz (Amps)	MVA Designation of VR-Series Breaker	Rated Voltage Factor K	Rated Withstand ANSI Test Voltage		Rated Short-Circuit kA RMS at Rated Max kV	Closing and Latching / Momentary Capabilities kA RMS/Peak
						Low Freq. kV RMS	Impulse kV Crest		
AMH-4.76-VR	4.16	250	1200 / 2000	250	1.24	19	60	29	58 / 97
	4.16	250	1200 / 2000	250U	1.19	19	60	41	78 / 132

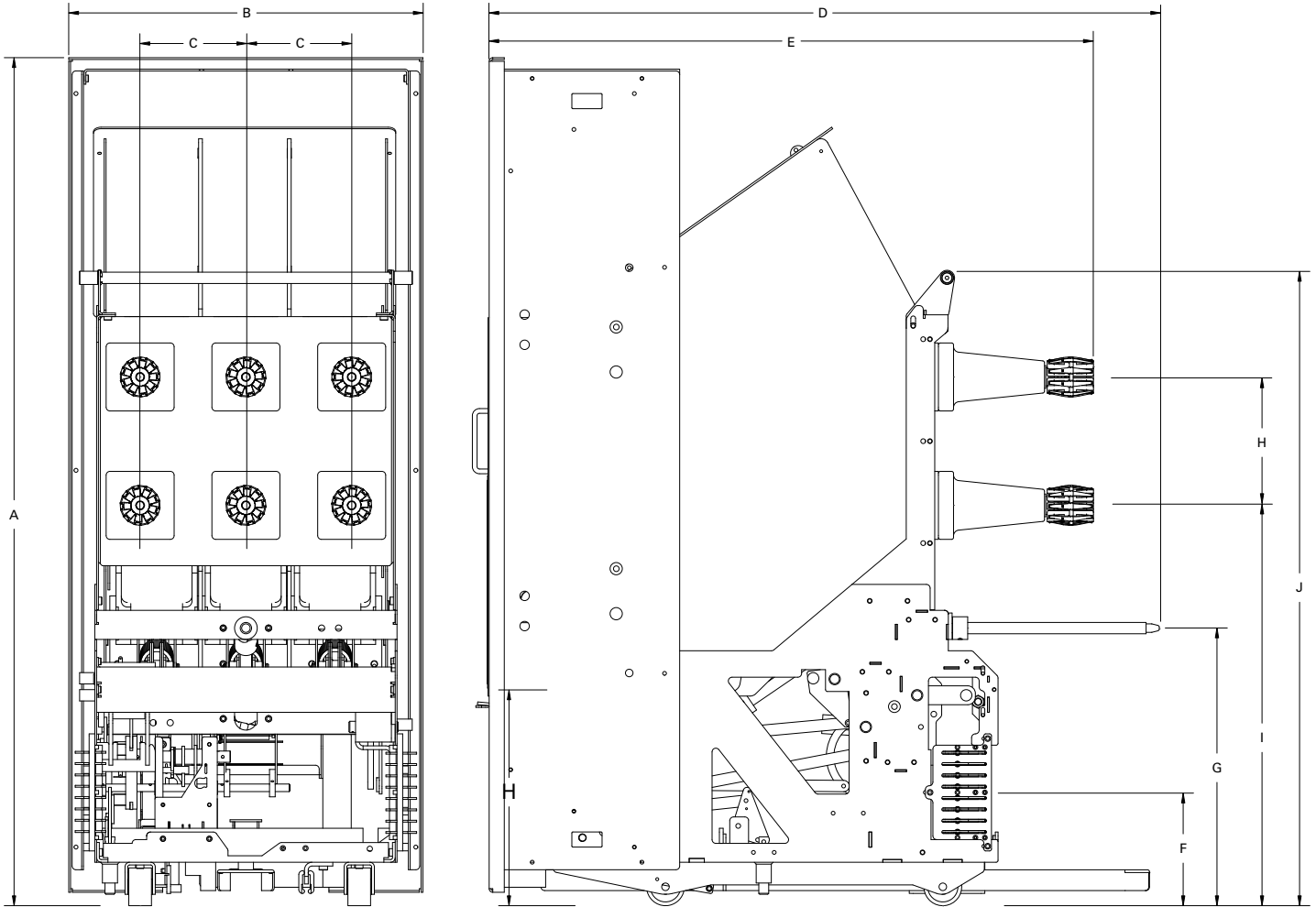

**Table 2. AMH-4.76-VR Dimensions**

Breaker Type	Existing Breaker Rated Continuous Current at 60 Hz (Amps)	A	B	C	D	E	F	G	H	I	J
AMH-4.76-VR 250/250U	1200 / 2000	56.02	23.44	7.00	44.42	40.07	7.50	18.38	26.50	8.50	42.00

## SECTION 2: SAFE PRACTICES

VR-Series breakers are equipped with high speed, high energy operating mechanisms. They are designed with several built-in interlocks and safety features to provide safe and proper operating sequences.

---

### **WARNING**

---

**TO PROTECT THE PERSONNEL ASSOCIATED WITH INSTALLATION, OPERATION, AND MAINTENANCE OF THESE BREAKERS, THE FOLLOWING PRACTICES MUST BE FOLLOWED:**

---

- **Only qualified persons, as defined in the National Electrical Safety Code, who are familiar with the installation and maintenance of medium voltage circuits and equipment, should be permitted to work on these breakers.**
- **Read these instructions carefully before attempting any installation, operation or maintenance of these breakers.**
- **Always remove the breaker from the enclosure before performing any maintenance. Failure to do so could result in electrical shock leading to death, severe personnel injury and/or property damage.**
- **Do not work on a breaker with the secondary test coupler engaged. Failure to disconnect the test coupler could result in an electrical shock leading to death, personnel injury and/or property damage.**
- **Do not work on a closed breaker or a breaker with closing springs charged. The closing spring should be discharged and the main contacts open before working on the breaker. Failure to do so could result in cutting or crushing injuries.**
- **Do not use a circuit breaker by itself as the sole means of isolating a high voltage circuit. Remove the breaker to the Disconnect position and follow all lockout and tagging rules of the National Electrical Code and any and all applicable codes, regulations and work rules.**
- **Do not leave the breaker in an intermediate position in the cell. Always have the breaker either in the Test or Connected position. Failure to do so could result in a flash over and possible death, personnel injury or property damage.**
- **Always remove the maintenance tool from the breaker after charging the closing springs.**
- **Breakers are equipped with safety interlocks. Do not defeat them. This may result in death, bodily injury or equipment damage.**

## SECTION 3: RECEIVING, HANDLING, AND STORAGE

Type AMH-4.76 VR-series circuit breakers are subjected to complete factory production tests and inspection before being packed. They are shipped in packages designed to provide maximum protection to the equipment during shipment and storage and at the same time to provide convenient handling. Accessories such as the maintenance tool, cell code plate, (if applicable) etc. are shipped with the breaker (Figure 3.1).

### 3.1 RECEIVING

Until the breaker is ready to be delivered to the switchgear site for installation, DO NOT remove it from the shipping crate. If the breaker is to be placed in storage, maximum protection can be obtained by keeping it in its crate.

Upon receipt of the equipment, inspect the crates for any signs of damage or rough handling. Open the crates carefully to avoid any damage to the contents. Use a nail puller rather than a crow bar when required.

When opening the crates, be careful that any loose items or hardware are not discarded with the packing material. Check the contents of each package against the packing list.

Examine the breaker for any signs of shipping damage such as broken, missing or loose hardware, damaged or deformed insulation and other components. File claims immediately with the carrier if damaged or loss is detected and notify the nearest Eaton's Electrical Services & Systems office.

#### Tools and Accessories

**Maintenance Tool / Manual Charge Handle:** This tool is used to manually charge the closing spring. One maintenance tool is provided with each vacuum unit replacement breaker. (Style# 94C9506G01)

**Racking Handle:** The racking handle is used to drive the racking mechanism which moves the circuit breaker into and out of the cell. The original OEM racking handle will interface with the VR-Series replacement breaker racking mechanism and is therefore not provided as part of the vacuum replacement breaker. A replacement racking handle may be purchased directly from Eaton. (Style# 5D11330G01)

Figure 3.1.a. Typical Manual Charge Handle



Figure 3.1.b. Rotary Racking Handle



### 3.2 HANDLING

#### **⚠ WARNING**

**DO NOT USE ANY LIFTING DEVICE AS A PLATFORM FOR PERFORMING MAINTENANCE, REPAIR OR ADJUSTMENT OF THE BREAKER OR FOR OPENING, CLOSING THE CONTACTS OR CHARGING THE SPRINGS. THE BREAKER MAY SLIP OR FALL CAUSING SEVERE PERSONAL INJURY. ALWAYS PERFORM MAINTENANCE, REPAIR AND ADJUSTMENTS ON A WORKBENCH CAPABLE OF SUPPORTING THE BREAKER TYPE.**

VR-Series breaker shipping containers are designed to be handled either by use of an overhead lifting device or by a fork lift truck. If containers must be skidded for any distance, it is preferable to use roller conveyors or individual pipe rollers.

Once a breaker has been inspected for shipping damage, it is best to return it to its original shipping crate until it is ready to be installed in the Metal-Clad Switchgear.

When the breaker is ready for installation, a lifting harness in conjunction with an overhead lift or portable floor lift can be used to move the breaker. If the breaker is to be lifted, position the lifting device over the breaker and insert the lifting harness hooks into the breaker side lifting points and secure (lifting straps should have at least a 500lbs lift capacity over the approximate breaker weight). Be sure the hooks are firmly attached before lifting the breaker. Stand a safe distance away from the breaker while lifting and moving.

Figure 3.2. Lifting AMH-4.76-VR



# AMH-4.76-VR Replacement Circuit Breaker

## 3.3 STORAGE

If the circuit breaker is to be placed in storage, maximum protection can be obtained by keeping it in the original shipping crate. Before placing it in storage, checks should be made to make sure that the breaker is free from shipping damage and is in satisfactory operating condition.

The breaker is shipped with its contacts open and closing springs discharged. The indicators on the front panel should confirm this. Insert the maintenance tool in the manual charge socket opening (Figure 3.3, 3.5, & 3.7). Charge the closing springs by pumping the handle up and down about 36 times until a crisp metallic “click” is heard. This indicates that the closing springs are charged and is shown by the closing spring “charged” (yellow) indicator. Remove the maintenance tool. Push the “manual close” button. The breaker will close as shown by the breaker contacts “closed” (red) indicator. Push the “manual trip” button. The breaker will trip as shown by the breaker contacts “open” (green) indicator. After completing this initial check, leave the closing springs “discharged” and breaker contacts “open”.

Outdoor storage is NOT recommended. If unavoidable, the outdoor location must be well drained and a temporary shelter from sun, rain, snow, corrosive fumes, dust, dirt, falling objects, excessive moisture, etc. must be provided. Containers should be arranged to permit free circulation of air on all sides and temporary heaters should be used to minimize condensation. Moisture can cause rusting of metal parts and deterioration of high voltage insulation. A heat level of approximately 400 watts for each 100 cubic feet of volume is recommended with the heaters distributed uniformly throughout the structure near the floor.

Indoor storage should be in a building with sufficient heat and circulation to prevent condensation. If the building is not heated, the same general rule for heat as for outdoor storage should be applied.

## 3.4 AMH-4.76-VR APPROXIMATE WEIGHTS

Refer to Table 3.

**Table 3. Maximum Weight by Type**

Type	Amperes	LBs
AMH-4.76-VR 250	1200	535
	2000	785
AMH-4.76-VR 250U	1200	535
	2000	785



Figure 3.3. Front External View of AMH-4.76-VR

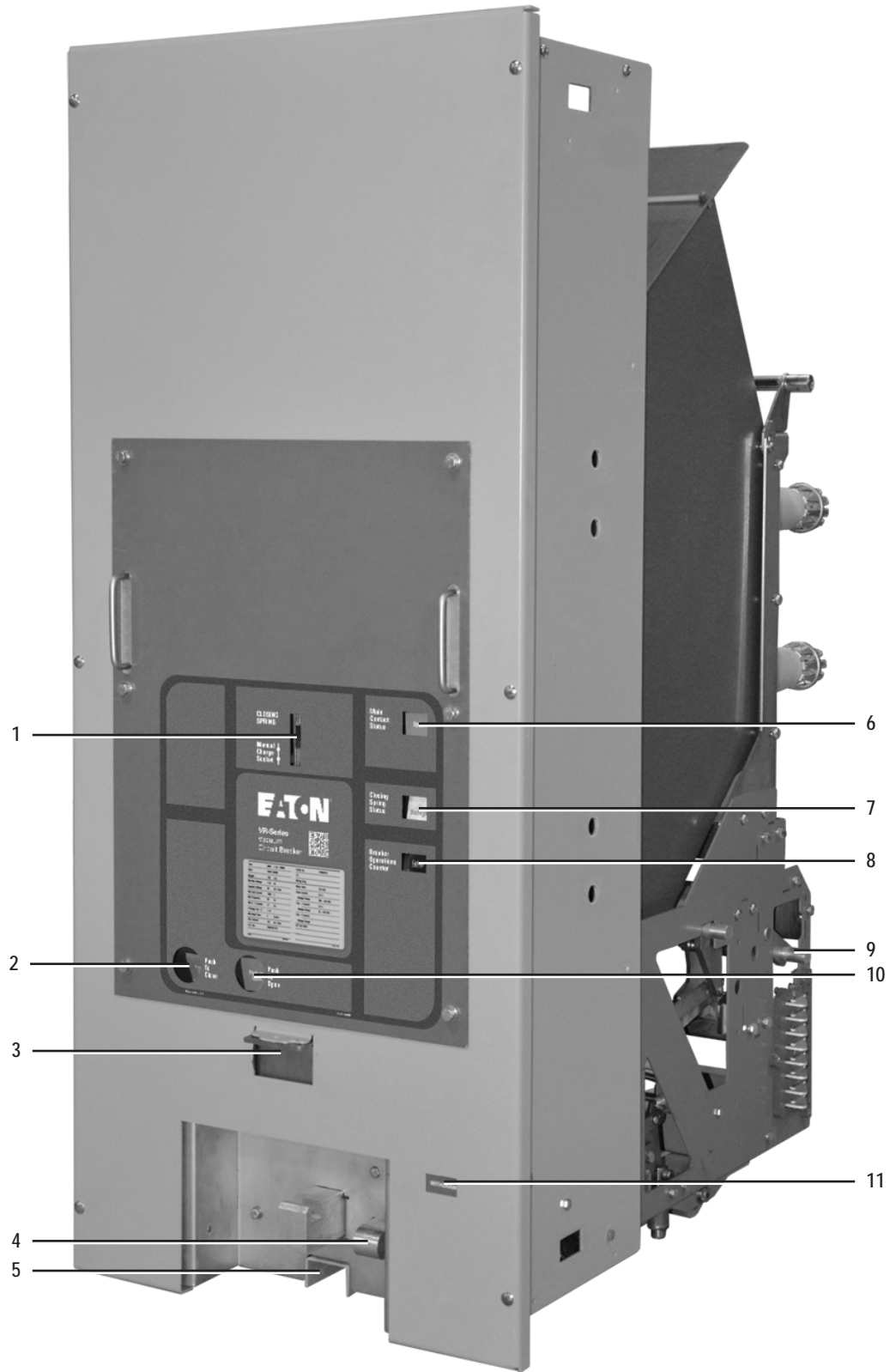

**Front External View**

1	Manual Charging Socket	5	Guide Bar	9	MOC Actuator
2	Push To Close Button	6	Breaker Contacts Indicator	10	Push To Open Button
3	Racking Access Door	7	Springs Charge/Discharge	11	Position Indicator
4	Foot Pedal	8	Operations Counter		

AMH-4.76-VR  
Replacement Circuit Breaker

Figure 3.4. Rear External View of AMH-4.76-VR

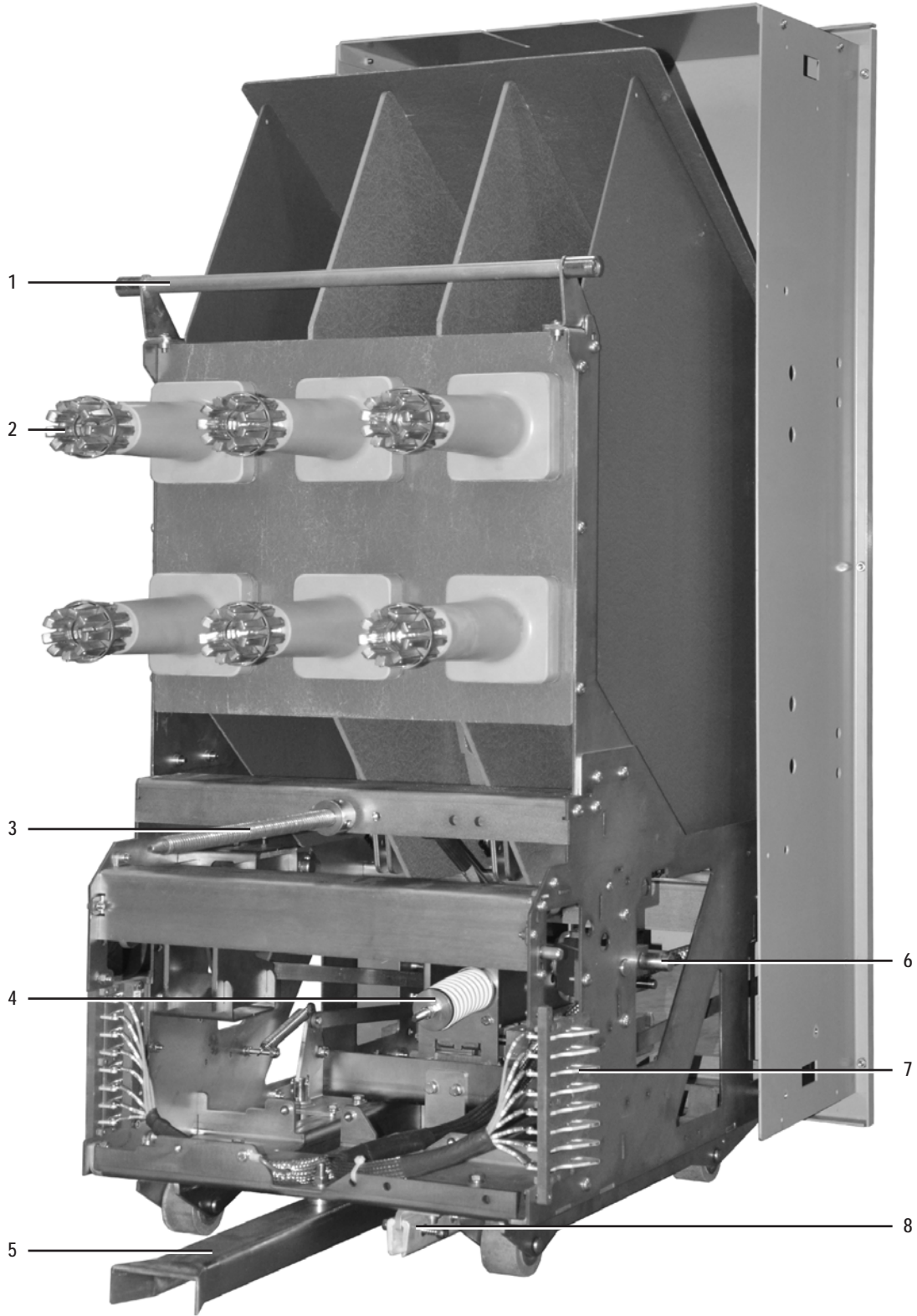

**Rear External View**

1 Shutter Actuator

4 SURE CLOSE Spring

7 Secondary Disconnect

2 Primary Disconnect

5 Guide Rail

8 Ground Contact

3 Racking Screw

6 Racking Access Door Interlock

## SECTION 4: DESCRIPTION AND OPERATION

VR-Series vacuum replacement breakers are designed to be used with existing installations of equivalent air-magnetic metal-clad switchgear breakers. The front mounted spring type stored energy mechanism facilitates inspection and provides improved access to components for servicing. The long life characteristics of the vacuum interrupters and proven high reliability of spring-type stored energy mechanisms assure long, trouble-free service with minimum maintenance.

VR-Series element designation is easily identified by the mechanism chassis width. See Table below.

VR-SERIES ELEMENT DESIGNATION	APPROXIMATE MECHANISM CHASSIS WIDTH (INCH)
18WR	18
20WR	20
29WR	27

### 4.1 VACUUM INTERRUPTER

Vacuum interrupters offer the advantages of enclosed arc interruption, small size and weight, longer life, reduced maintenance, minimal mechanical shock, and elimination of contact degradation caused by environmental contamination.

In the closed position, current flows through the interrupter moving and fixed stems and the faces of the main contacts. As the contacts part, an arc is drawn between the contact surfaces. The arc is rapidly moved away from the main contacts to the slotted contact surfaces by self-induced magnetic effects. This minimizes contact erosion and hot spots on the contact surfaces. The arc flows in an ionized metal vapor and as the vapor leaves the contact area, it condenses into the metal shield which surrounds the contacts.

At current zero, the arc extinguishes and vapor production ceases. Very rapid dispersion, cooling, recombination, and deionization of the metal vapor plasma and fast condensation of metal vapor causes the vacuum to be quickly restored and prevents the transient recovery voltage from causing a restrike across the gap of the open contacts.

#### 4.1.1 THE INTERRUPTER ASSEMBLY

Each interrupter is assembled at the factory as a unit to assure correct dimensional relationships between working components. The interrupter assembly consists of a vacuum interrupter, a molded glass polyester stand-off insulator, upper and lower clamps, flexible shunts, bell crank, operating rod, and contact load spring. The vacuum interrupter is mounted vertically with the fixed stem upward and the moving stem downward. The upper and lower glass polyester stand-off insulator and clamps support the interrupter and are fastened to the breaker's stored energy mechanism frame. Upper and lower flexible shunts provide electrical connections from each interrupter to the breaker's primary bushings while providing isolation from mechanical shock and movement of the interrupter's moving stem. The operating rod, loading spring, and bell crank transfer mechanical motion from the breaker's operating mechanism to the moving stem of the interrupter. A vacuum interrupter contact erosion indicator is located on the moving stem of the interrupter. It is visible when the breaker is withdrawn and is viewed from the rear of the breaker. (See Figure 6.1 and Figure 6.2)

#### 4.1.2 CONTACT EROSION INDICATOR

The purpose of the contact erosion indicator is to monitor the erosion of the vacuum interrupter contacts, which is very minimal over time with Eaton vacuum interrupters utilizing copper-chrome contact material. A contact erosion indicator mark is located on the moving stem of the interrupter (Figure 6.1 and 6.2).

In order to determine if the contacts have eroded to the extent that the interrupter must be replaced, close the breaker and observe the erosion mark placed on each moving stem from the rear of the

Figure 4.1. 18WR Interrupter Assembly



Figure 4.2. 18WR Interrupter Assembly (All Three Pole Units)



## AMH-4.76-VR Replacement Circuit Breaker

breaker. If the mark on the interrupter stem is visible, the interrupter is satisfactory. If the mark is no longer visible, the interrupter assembly must be replaced.

The erosion indicator is easily viewed from the rear on the 5kV, 7.5kV or 15kV designs.

---

### **⚠ WARNING**

**FAILURE TO REPLACE THE INTERRUPTER ASSEMBLY WHEN INDICATED BY THE CONTACT EROSION INDICATOR COULD CAUSE THE BREAKER TO FAIL, LEADING TO DEATH, PERSONAL INJURY OR PROPERTY DAMAGE.**

---

#### 4.1.3 CONTACT WIPE AND STROKE

Contact wipe is the indication of the force holding the vacuum interrupter contacts closed and the energy available to hammer the contacts open with sufficient speed for interruption.

Stroke is the gap between fixed and moving contacts of a vacuum interrupter with the breaker open.

The circuit breaker mechanism provides a fixed amount of motion to the operating rods. The first portion of the motion is used to close the contacts (i.e. stroke) and the remainder is used to further compress the preloaded wipe spring. This additional compression is called wipe. Wipe and stroke are thus related to each other. As the stroke increases due to the erosion of contacts, the wipe decreases. A great deal of effort and ingenuity has been spent in the design of VR-Series breakers, in order to eliminate any need for field adjustment of wipe or stroke.

---

### **⚠ WARNING**

**THERE IS NO PROVISION FOR IN-SERVICE ADJUSTMENTS OF CONTACT WIPE AND STROKE. ALL SUCH ADJUSTMENTS ARE FACTORY SET AND SHOULD NOT BE ATTEMPTED IN THE FIELD.**

---

#### 4.2 PHASE BARRIERS

Phase barriers are sheets of insulation located between the interrupter pole assemblies and on the sides of the breaker frame. The phase barriers are designed to isolate energized conductor components in each phase from the adjacent phase and ground.

---

### **⚠ WARNING**

**ALL PHASE BARRIERS MUST BE IN PLACE BEFORE PLACING THE CIRCUIT BREAKER INTO SERVICE. FAILURE TO HAVE THEM IN POSITION CAN CAUSE DEATH, SERIOUS PERSONNEL INJURY AND/OR PROPERTY DAMAGE.**

---

#### 4.3 BUSHINGS AND DISCONNECTING CONTACT ASSEMBLIES

The line and load bushing assemblies, which are the primary circuit terminals of the circuit breaker, consist of six silver plated conductors. Solid stab type primary disconnecting contacts at the ends of the conductors provide means for connecting and disconnecting the breaker to the bus terminals in the switchgear compartment.

#### 4.4 STORED ENERGY MECHANISM

The spring-type stored energy operating mechanism is mounted on the breaker frame and in the front of the breaker. Manual closing and opening controls are at the front panel (Figure 3.3). They are accessible while the breaker is in any of its four basic positions. (See Section 5 in this manual)

The mechanism stores the closing energy by charging the closing springs. When released, the stored energy closes the breaker, charges the wipe and resets the opening springs. The mechanism may rest in any one of the four positions shown in Figure 4.6 as follows:

- a. Breaker open, closing springs discharged.
- b. Breaker open, closing springs charged.
- c. Breaker closed, closing springs discharged.
- d. Breaker closed, closing springs charged.

The mechanism is a mechanically “trip-free” design. Trip-free is defined later in this section.

In normal operation the closing spring is charged by the spring charging motor, and the breaker is closed electrically by the switchgear control circuit signal to energize the spring release coil. Tripping is caused by energizing the trip coil through the control circuit.

For maintenance inspection purposes the closing springs can be charged manually by using the maintenance tool and the breaker can be closed and tripped by pushing the “Push to Close” and “Push to Open” buttons on the front panel.

---

### **⚠ WARNING**

**KEEP HANDS AND FINGERS AWAY FROM BREAKER'S INTERNAL PARTS WHILE THE BREAKER CONTACTS ARE CLOSED OR THE CLOSING SPRINGS ARE CHARGED. THE BREAKER CONTACTS MAY OPEN OR THE CLOSING SPRINGS DISCHARGE CAUSING CRUSHING INJURY. DISCHARGE THE SPRINGS AND OPEN THE BREAKER BEFORE PERFORMING ANY MAINTENANCE, INSPECTION OR REPAIR ON THE BREAKER.**

---

**THE DESIGN OF THIS CIRCUIT BREAKER ALLOWS MECHANICAL CLOSING AND TRIPPING OF THE BREAKER WHILE IT IS IN THE “CONNECT” POSITION. HOWEVER, THE BREAKER SHOULD BE CLOSED MECHANICALLY ONLY IF THERE IS POSITIVE VERIFICATION THAT LOAD SIDE CONDITIONS PERMIT. IT IS RECOMMENDED THAT CLOSING THE BREAKER IN THE “CONNECT” POSITION ALWAYS BE DONE WITH THE CUBICLE DOOR CLOSED. FAILURE TO FOLLOW THESE DIRECTIONS MAY CAUSE DEATH, PERSONAL INJURY, OR PROPERTY DAMAGE.**

---

**ELECTRICAL TRIPPING CAN BE VERIFIED WHEN THE BREAKER IS IN THE “TEST” POSITION.**

---

#### 4.4.1 CLOSING SPRING CHARGING

Figure 4.5 shows schematic section views of the spring charging parts of the stored energy mechanism.

The major component of the mechanism is a cam shaft assembly which consists of a shaft to which are attached two closing spring cranks (one on each end), the closing cam, drive plate, and a free-wheeling ratchet wheel.

The ratchet wheel (6) is actuated by an oscillating ratchet lever (12) and drive pawl (10) driven by the motor eccentric cam. As the ratchet wheel rotates, it pushes the drive plates which in turn rotate the closing spring cranks and the closing cam on the cam shaft. The motor will continue to run until the limit switch “LS” contact disconnects the motor.

The closing spring cranks have spring ends connected to them, which are in turn coupled to the closing springs. As the cranks rotate, the closing springs get charged.

The closing springs are completely charged, when the spring cranks go over dead center and the closing stop roller (9) comes against the spring release latch (1). The closing springs are now held in the fully charged position.

The closing springs may also be charged manually as follows: Insert the maintenance tool in the manual charging socket. Move it up and down several times (about 36) until a clicking sound is heard and closing spring status indicator shows “charged” (Figure 3.3). Any further motion of the maintenance tool will result in free wheeling of the ratchet wheel and will not result into advance of charging.

#### 4.4.2 CLOSING OPERATION

Figure 4.6 shows the positions of the closing cam and tripping linkage for four different operational states. In Figure 4.6.a the breaker is open and the closing springs are discharged. In this state, the trip latch is disengaged from the trip “D” shaft (unlatched). After the closing springs become charged, the trip latch snaps into the fully reset or latched position (Figure 4.6.b)

When the spring release clapper (Figure 4.5, Item 13) moves into the face of the spring release coil (electrically or manually), the upper portion of the clapper pushes the spring release latch (1) upward. When the spring release latch moves, the cam shaft assembly is free to rotate. The force of the closing cam (Figure 4.6.b, Item 5), moving the main link (2), rotating the pole shaft (4) (which charges the opening spring). This moves the three operating rods (3), closes the main contacts and charges the contact loading springs (not shown). The operational state immediately after the main contacts close but before the spring charging motor recharges the closing springs is illustrated in Figure 4.6.c. Interference of the trip “D” shaft with the trip latch prevents the linkage from collapsing, and holds the breaker closed.

Figure 4.6.d shows the breaker in the closed state after the closing springs have been recharged. The recharging of the spring rotates the closing cam one half turn. In this position the main link roller rides on the cylindrical portion of the cam, and the main link does not move out of position.

#### 4.4.3 TRIPPING OPERATION

When the trip bar “D” shaft (Figure 4.6.b, Item 9) is turned by movement of the shunt trip clapper (11), the trip latch will slip past the straight cut portion of the trip bar shaft and will allow the banana link and main link roller to rise. The energy of the opening spring and contact loading springs is released to open the main contacts. The mechanism is in the state illustrated (Figure 4.6.b) after the breaker is tripped open.

#### 4.4.4 TRIP-FREE OPERATION

When the manual trip button is held depressed, any attempt to close the breaker results in the closing springs discharging without any movement of the pole shaft or vacuum interrupter stem.

#### 4.5 CONTROL SCHEMES

There are two basic control schemes for each series of Type VCP-VR breakers, one for DC control and one for AC control voltages (Figure 4.3). Specific wiring schematics and diagrams are included with each breaker.

There may be different control voltages or more than one tripping element, but the principal mode of operation is as follows:

As soon as the control power is applied, the spring charging motor automatically starts charging the closing spring. When the springs are charged, the motor cut off LS1/bb switch turns the motor off. The breaker may be closed by making the control switch close (CS/C) contact. Automatically upon closing of the breaker, the motor starts charging the closing springs. The breaker may be tripped any time by making the control switch (CS/T) contacts.

Note the position switch (PS1) contact in the spring release circuit in the scheme. This contact remains made while the breaker is being racked between the TEST and CONNECTED positions for appropriately retrofitted breakers. Consequently, it prevents the breaker from closing automatically, even though the control close contact may have been made while the breaker is racked to the CONNECTED position.

When the CS/C contact is made, the SR closes the breaker. If the CS/C contact is maintained after the breaker closes, the Y relay is picked up. The Y/a contact seals in Y until CS/C is opened. The Y/b contact opens the SR circuit, so that even though the breaker would subsequently open, it could not be reclosed before CS/C was released and remade. This is the anti-pump function.

#### 4.5.1 TIMING

The opening and closing times for the circuit breakers vary depending upon the control voltage, power rating, environment and test equipment. Differences in timing are expected between initial factory measurements and field inspections. Circuit breaker timing can be measured by service personnel using available equipment before installation and in conjunction with regular maintenance periods to assist in tracking the general health of the breaker. Typical ranges as observed using nominal control voltages are listed in Table 4.

**Table 4. Time Per Event**

Event	Milliseconds / Maximum
Closing Time (From Initiation of Close Signal to Contact Make)	75
Opening Time (Initiation of Trip Signal to Contact Break)	45
Reclosing Time (Initiation of Trip Signal to Contact Make)	190

#### 4.6 SECONDARY CONNECTION BLOCK

The breaker control circuit is connected to the switchgear control through secondary connection block, located at the lower left rear of the breaker. The contacts engage automatically when the breaker is racked into the “test” and “connect” positions. The socket half of the connection is located in the cubicle and a jumper of multiconductor cable can complete the control connections (for testing) when the breaker is withdrawn from the cell.

#### 4.7 INTERLOCKS

### **⚠ WARNING**

**INTERLOCKS ARE PROTECTIVE DEVICES FOR PERSONNEL AND EQUIPMENT. DO NOT BYPASS, MODIFY, OR MAKE INOPERATIVE ANY INTERLOCKS. DOING SO COULD CAUSE DEATH, SERIOUS PERSONAL INJURY, AND/OR PROPERTY DAMAGE.**

There are several interlocks built into the VR-Series vacuum replacement breakers. Each of these interlocks, though different in form, duplicate or exceed in function that of the original breaker. These interlocks exist to safeguard personnel and equipment. The basic premise behind the interlocking arrangement on the vacuum replacement breaker is that the breaker must not be inserted into or removed from a live circuit while the main contacts are closed. Also considered in the interlocking is that the breaker should pose no greater risk than necessary to the operator in or out of the cell. In addition to the original interlocks, VR-Series breakers provide an anti-close interlock.

#### 4.7.1 ANTI-CLOSE INTERLOCK

The anti-close interlock prevents discharging of the closing springs if the breaker is already closed (Figure 4.5, Item 11). When the breaker is closed, the interlock component moves away from the spring release clapper so that it cannot lift the spring release latch (9).

#### 4.7.2 RACKING SYSTEM TRIP AND SPRING RELEASE INTERLOCKS

The racking interlock prevents engaging or disconnecting a shut breaker with live cell buss work or removing a mechanically hazardous breaker from the cell. The basic premise of this interlock is that no breaker should be connected to or removed from cell primary circuitry when shut and no breaker should be removed from the cell with charged open or closing springs. The racking

Figure 4.3. Typical AC/DC Schematic

### VR-Series Circuit Breaker dc Control Schematic

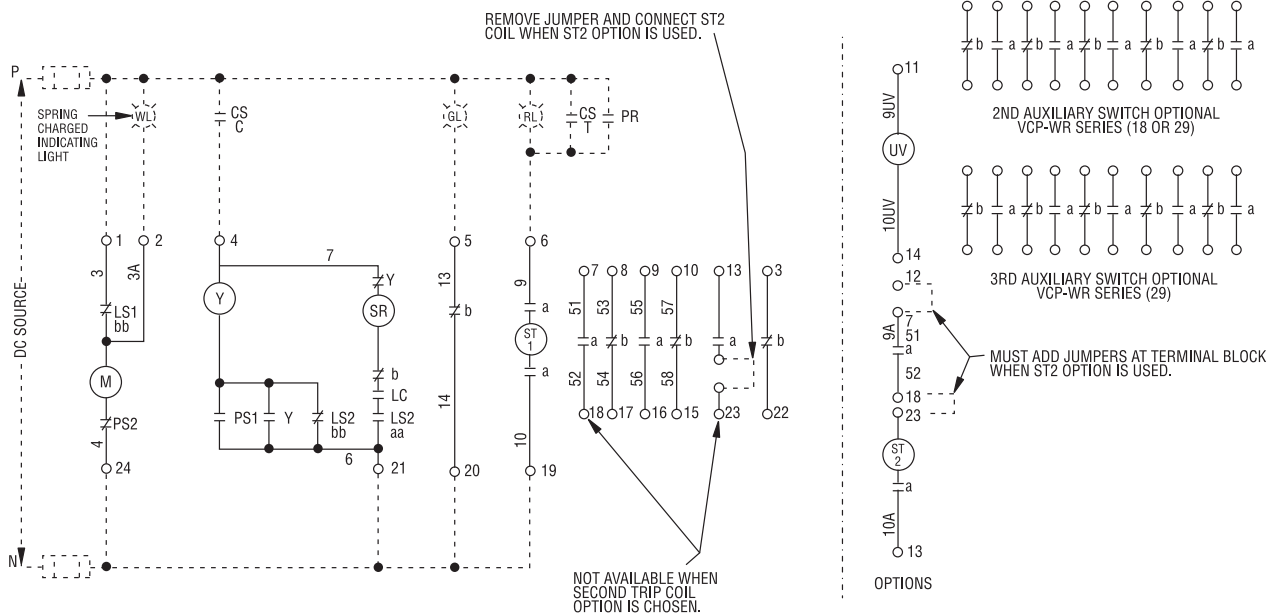

### VR-Series Circuit Breaker ac Control Schematic

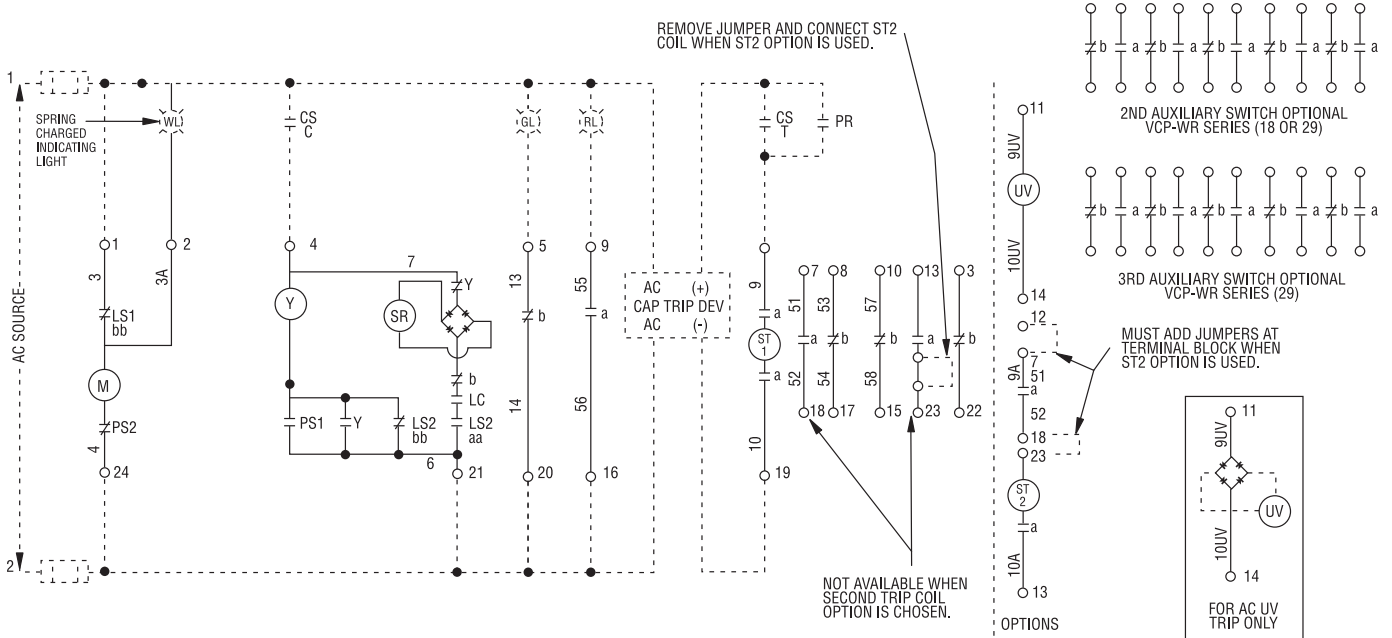

#### OPERATION

CS - Breaker Control Switch - close  
C

CS - Breaker Control Switch - trip  
T

Y - Anti Pump Relay

SR - Spring Release Coil (Close Coil)

M - Spring Charging Motor

ST - Shunt Trip Coil

PR - Protective Relay

O - Terminal Block or Accessible Terminal

PS1 - Position Switch 1

PS2 - Position Switch 2

LS1 bb - Closed until springs are fully charged

LS2 aa - Open until springs are fully charged

LS2 bb - Closed until springs are fully charged

LC - Open until mechanism is reset

PS1 - Open in all except between 'Test' and 'Connect' positions

PS2 - Closed in all except between 'Test' and 'Connect' positions

#### SWITCH TERMINAL

'C' and 'NO' - Brown Switch

'C' and 'NC' - Black Switch

'C' and 'NO' - Black Switch

'C' and 'NO' - Black Switch

'C' and 'NO' - Brown Switch

interlock accomplishes this by providing a trip signal to the breaker automatically from the racking mechanism interlock cams whenever the breaker is in an intermediate position in the cell and adding a close signal between the DISCONNECT and WITHDRAWN positions to render the breaker trip-free prior to leaving the cell (close and open springs discharged).

---

**⚠ WARNING**

**DO NOT FORCE THE BREAKER INTO THE CELL. DOING SO MAY DAMAGE PARTS THEREBY RISKING DEATH, PERSONAL INJURY, AND/OR PROPERTY DAMAGE.**

---

## 4.8 MISCELLANEOUS ITEMS

### 4.8.1 MOC OPERATOR

The MOC switch is external to the circuit breaker and mounted within the confines of the switchgear cubicle. The breaker's MOC operator interfaces with the cell MOC switch in the same manner as the original breaker being replaced. All VR-Series breakers, which are supplied with MOC operators, are engineered with patented **SURE CLOSE** Technology. This technology decouples the MOC operator from the main breaker operating mechanism. This prevents the MOC switch from stalling the circuit breaker during a closing operation, preventing damage to the cell MOC components, and extends the life of the MOC switch.

---

**⚠ WARNING**

**EXTREME CARE SHOULD BE TAKEN TO AVOID PERSONNEL OR EQUIPMENT CONTACT WITH THE MOC SYSTEM WHEN OPERATING THE BREAKER DUE TO THE ASSOCIATED MECHANICAL FORCE. CONTACT WITH THE MOC OPERATOR DURING OPERATION COULD RESULT IN INJURY.**

---

### 4.8.2 OPERATIONS COUNTER

All AMH-4.76-VR breakers are equipped with a mechanical operations counter (Figures 3.3). As the breaker opens, the linkage connected to the pole shaft lever advances the counter reading by one.

AMH-4.76-VR  
Replacement Circuit Breaker

Figure 4.4. 18WR Vacuum Element - Front Faceplate Removed

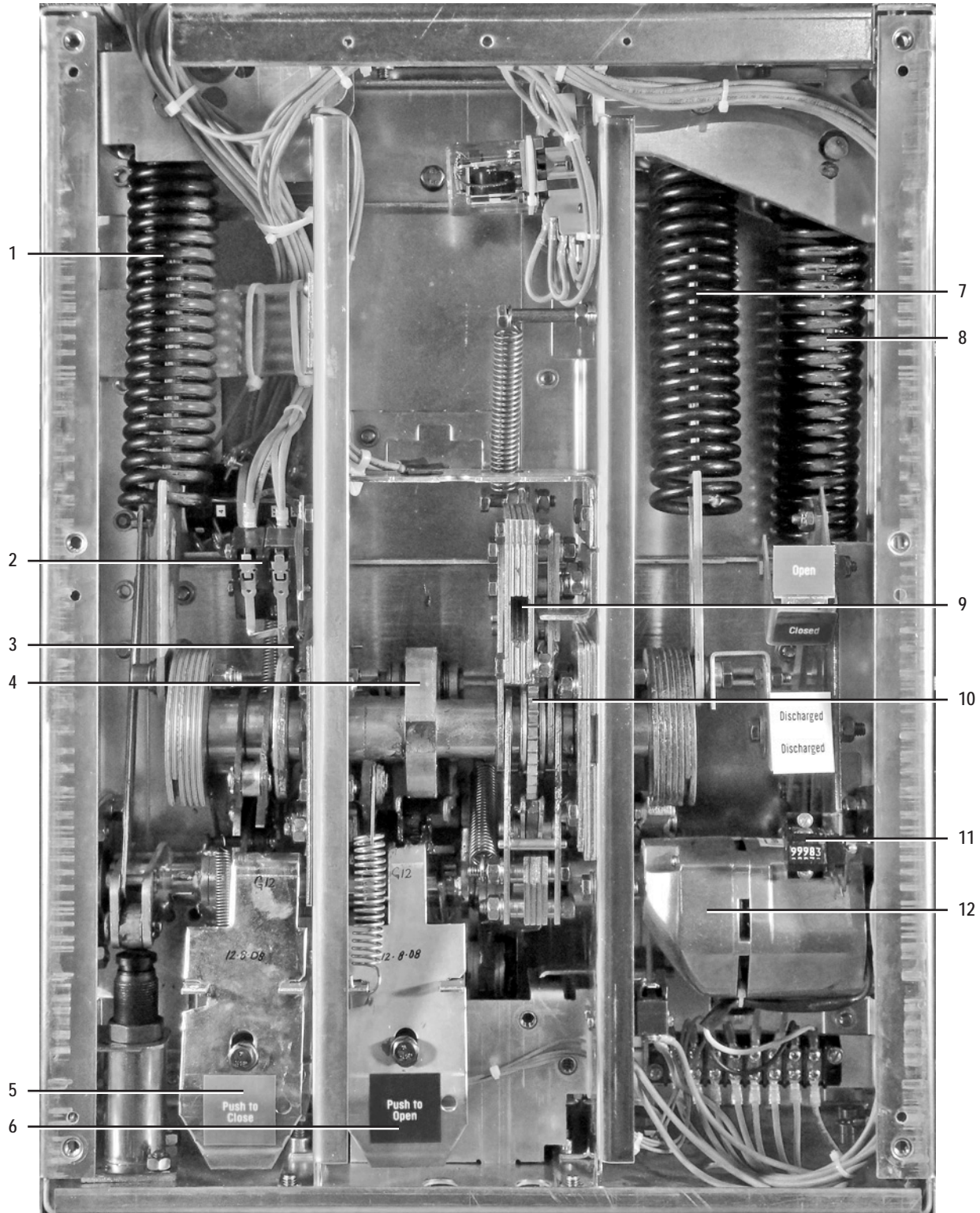

**18WR Vacuum Element**

1	LH Closing Spring	5	Spring Release Assembly	9	Manual Charge Socket
2	Motor Cutoff Switch	6	Shunt Trip Assembly	10	Ratchet wheel
3	Latch Check Switch (Rear)	7	RH Closing Spring	11	Operations Counter
4	Closing Cam	8	Reset / Opening Spring	12	Charging Motor



Figure 4.5. Closing Cam and Trip Linkage

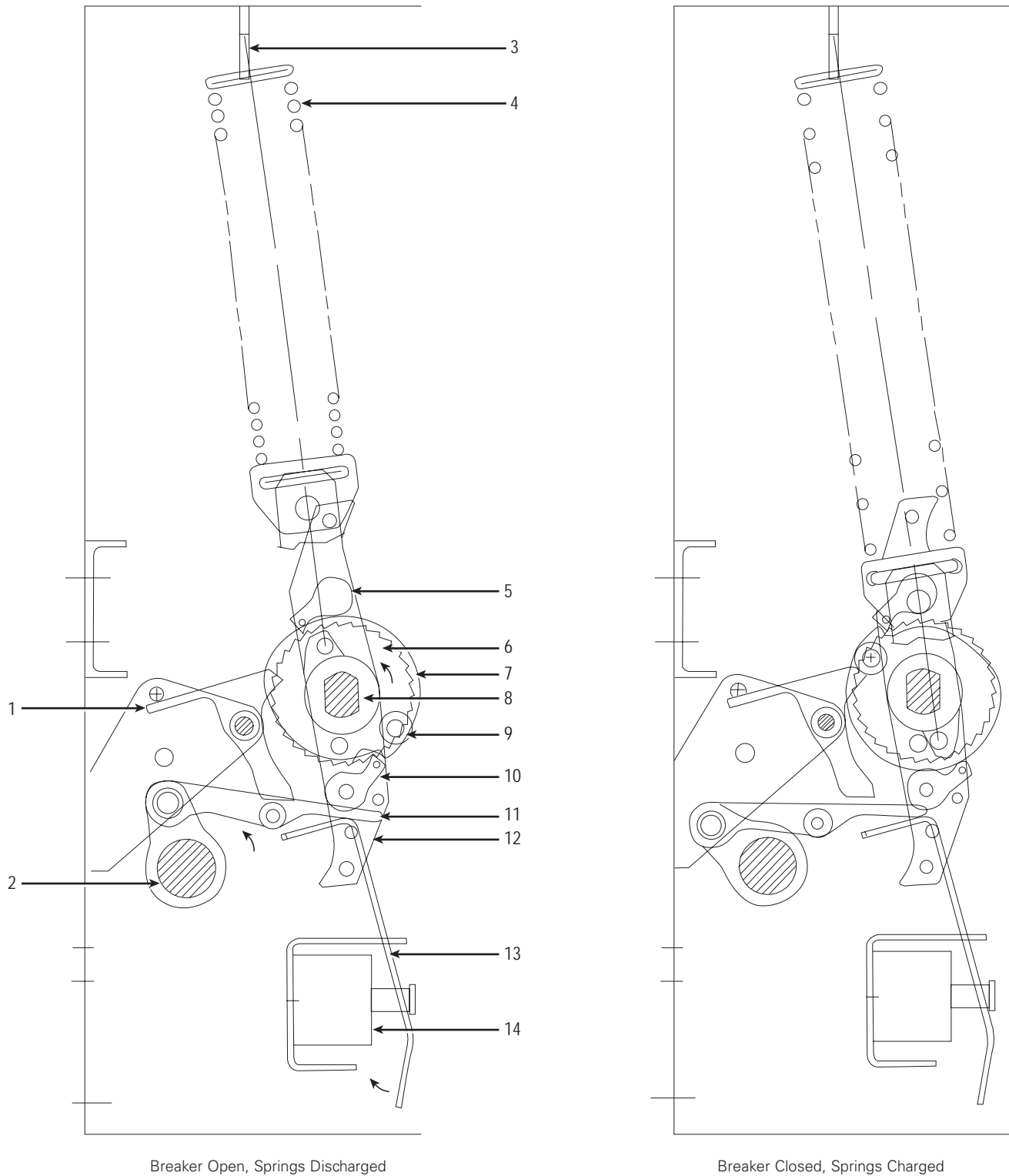

Breaker Open, Springs Discharged

Breaker Closed, Springs Charged

**Closing Cam and Trip Linkage**

1	Spring Release (Close) Latch	6	Ratchet Wheel	11	Anti-Close Interlock
2	Pole Shaft	7	Spring Crank	12	Motor Ratchet Lever
3	Closing Spring Fixed End	8	Cam Shaft	13	Spring Release (Close) Clapper
4	Closing Spring	9	Spring Release Latch (Close Roller)	14	Spring Release (Close) Coil
5	Holding Pawl (Electrical Charging) / Drive Pawl (Manual Charging)	10	Drive Pawl (Electrical Charging) / Holding Pawl (Manual Charging)		

# AMH-4.76-VR Replacement Circuit Breaker

Figure 4.6. Charging Schematic

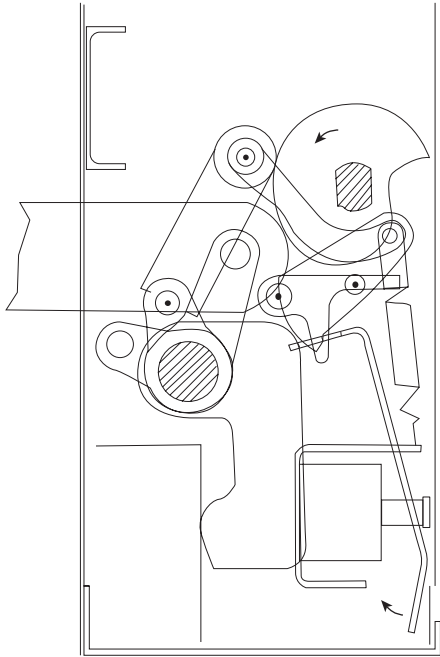

4.9.a. Breaker Open and Closing Spring Discharged

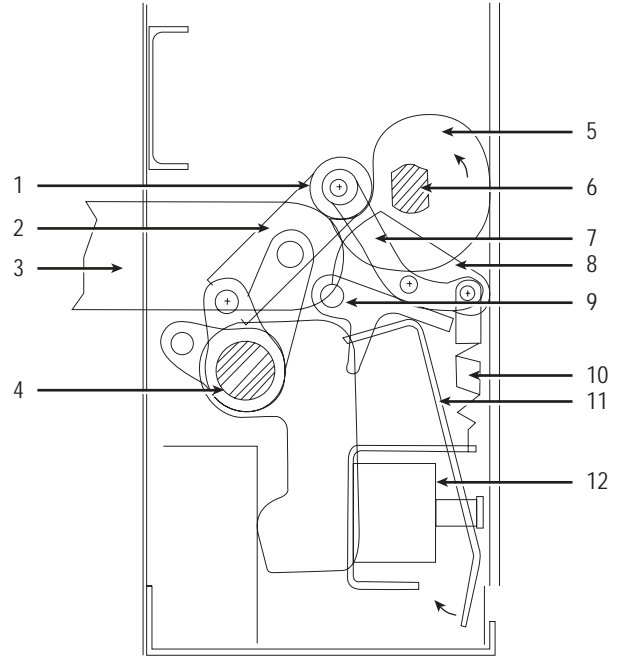

4.9.b. Breaker Open and Closing Spring Charged

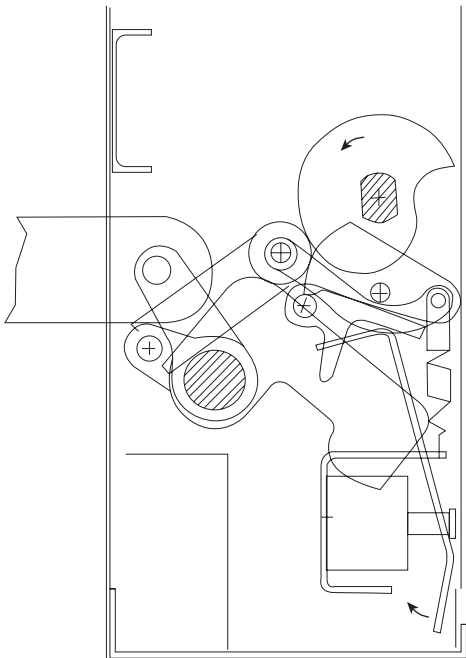

4.9.c. Breaker Closed and Closing Spring Discharged

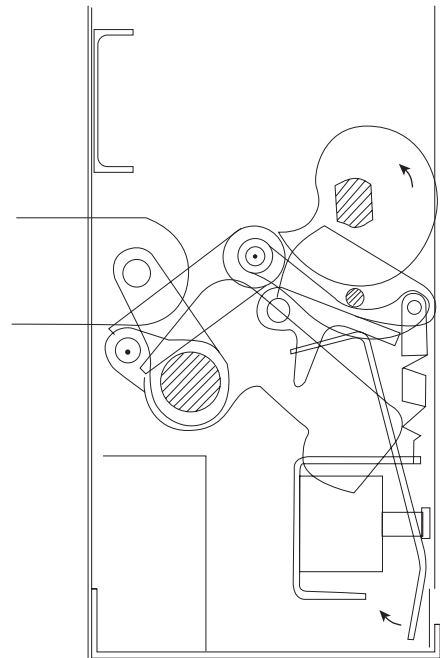

4.9.d. Breaker Closed and Closing Spring Charged

### Charging Schematic

1	Main Link Roller	5	Closing Cam	9	Trip Bar "D" Shaft
2	Main Link	6	Cam Shaft	10	Trip Latch Reset Spring
3	Operating Rod	7	Banana Link	11	Shunt Trip Lever
4	Pole Shaft	8	Trip latch	12	Shunt Trip Coil

## SECTION 5: INSPECTION & INSTALLATION

### **⚠ WARNING**

**BEFORE PLACING THE BREAKER IN SERVICE, CAREFULLY FOLLOW THE INSTALLATION PROCEDURE BELOW AND THE SAFE PRACTICES SET FORTH IN SECTION 2. NOT FOLLOWING THE PROCEDURE MAY RESULT IN INCORRECT BREAKER OPERATION LEADING TO DEATH, BODILY INJURY, AND PROPERTY DAMAGE.**

When the breaker is first commissioned into service and each time the breaker is returned to service, it should be carefully examined and checked to make sure it is operating correctly.

### 5.1 EXAMINATION FOR DAMAGE

Examine the breaker for loose or obviously damaged parts. Never attempt to install nor operate a damaged breaker.

#### 5.1.1 NAMEPLATE VERIFICATION

Verify the information on the new VR-Series nameplate matches the information on the purchase order. If any discrepancies exist, notify Eaton's Electrical Services & Systems for resolution prior to proceeding.

### **⚠ WARNING**

**ALWAYS DE-ENERGIZE/ISOLATE THE POWER SOURCE FEEDING THE POWER CIRCUIT BREAKERS/SWITCHGEAR AND LOCK-OUT/TAG-OUT THE POWER SOURCE PRIOR TO INSERTION OR REMOVAL OF ANY POWER CIRCUIT BREAKER. NEVER ATTEMPT TO MAINTAIN OR MODIFY A CIRCUIT BREAKER WHILE INSERTED IN A SWITCHGEAR CELL STRUCTURE. ALWAYS REMOVE THE POWER CIRCUIT BREAKER AND MOVE IT TO A SUITABLE AREA FOR MAINTENANCE OR REPAIR.**

**FOLLOW ALL LOCKOUT AND TAG-OUT REQUIREMENTS OF THE NATIONAL ELECTRIC CODE, OSHA AND ANY OTHER APPLICABLE LOCAL CODES, REGULATIONS AND PROCEDURES.**

### 5.2 SURE CLOSE MECHANISM ADJUSTMENT

### **⚠ WARNING**

**FOR ALL TYPE BREAKER HOUSINGS EQUIPPED WITH MECHANISM OPERATED CELL (MOC) SWITCHES, THE STEPS OUTLINED IN THIS SECTION MUST BE PERFORMED BEFORE INSTALLING A REPLACEMENT VR-SERIES CIRCUIT BREAKER. FAILURE TO COMPLY COULD CAUSE SEVERE PERSONAL INJURY, DEATH, EQUIPMENT DAMAGE AND/OR IMPROPER OPERATION**

All type AMH-4.76-VR breakers utilize the AMH-4.76-VR **SURE CLOSE** mechanism to control kinetic energy transfer and closely mimic the dynamics and velocities of older breakers. It is imperative that this mechanism be adjusted to compensate for the force of the MOC switch mounted in the cell.

The breaker has been factory adjusted to operate one mechanism operated cell (MOC) switch in the cell. This means that for applications with either no MOC switch or one MOC switch, no field adjustments are required.

Finally, the **SURE CLOSE** mechanism provides an effective way to evaluate the condition of the MOC in the cell. If the **SURE CLOSE** drive spring is properly adjusted, but the MOC does not fully open or close, it is time to maintain the MOC in the cell. Maintenance usually means cleaning and lubricating the MOC mechanism. If the MOC has seen a large number of cycles, however, worn components may have to be replaced.

To insure the proper operation of the **SURE CLOSE** mechanism, the MOC assembly should be cleaned and inspected for worn parts and then lubricated. A spring force gauge should be used to measure the

Figure 5.1. **SURE CLOSE** Spring Compression Setting

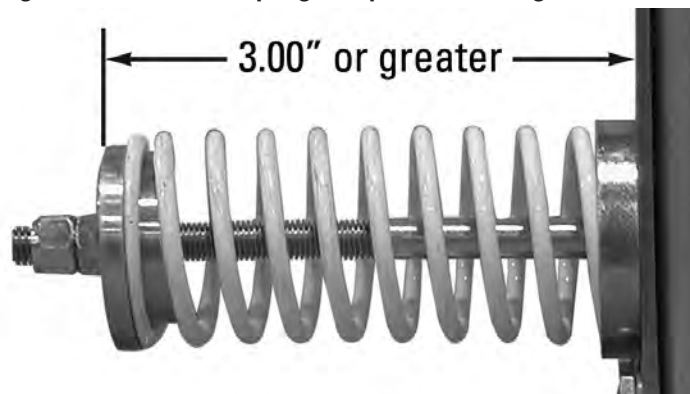

forces needed to move the switch to the fully closed position prior to inserting the breaker. The differential force of the assembly and the breaker should be a minimum of 10 lbs. with the breaker having the higher recorded force. Should the forces be less than that, proceed with the following steps to increase the breaker force:

### **⚠ WARNING**

**MEASUREMENTS AND ADJUSTMENTS SHOULD NEVER BE ATTEMPTED IN AN ENERGIZED STRUCTURE. IF THE STRUCTURE CAN NOT BE DE-ENERGIZED, THEN PROPER PERSONAL PROTECTIVE EQUIPMENT PER NFPA 70E MUST BE WORN AT ALL TIMES WHILE GATHERING MOC SWITCH DATA, ADJUSTING OR SERVICING THE MOC SWITCH. FAILURE TO COMPLY WITH THIS WARNING COULD CAUSE SEVERE PERSONAL INJURY, DEATH, EQUIPMENT DAMAGE AND/OR IMPROPER OPERATION.**

To adjust the **SURE CLOSE** drive spring for a specific number of MOC switches, proceed with the following steps:

- Step 1:** Locate the **SURE CLOSE** drive spring (Figure 3.3). It is located in the left lower portion of the breaker as viewed from the rear of the breaker.
- Step 2:** From the factory, the drive spring comes set with adequate force to operate one MOC switch, however, more force can be generated. Refer to Figure 5.1 to see how that adjustment would look. Notice that there is a nut and a jam nut on the threaded rod to make the adjustment easy.
- Step 3:** Using a spring gauge, measure the force required to operate the MOC to the fully closed position in the cell at the interface with the breaker.
- Step 4:** With the breaker out of the cell, close the breaker and measure the output of the MOC drive with a spring gauge. Open the breaker. The MOC drive force should exceed the MOC cell force required by 10 - 15lbs. If not, an adjustment is required.
- Step 5:** Loosen the jam nut on the **SURE CLOSE** spring and compress the spring an additional .25 inches. Close the breaker.

### **⚠ WARNING**

**WITH THE BREAKER IN THE OPEN POSITION, THE SPRING COMPRESSION SHOULD NEVER BE SET TO A DIMENSION LESS THAN 3 INCHES AS MEASURED IN FIGURE 5.1.**

- Step 6:** Remeasure the MOC output spring force in the closed position. Repeat until the MOC forces are adequate.
- Step 7:** Insert into the cell.
- Step 8:** Operate the breaker to verify the new setting.
- Step 9:** Repeat steps 3 - 7 until acceptable operation is achieved.
- Step 10:** Anytime an adjustment is made, make sure the new compressed spring length (measured in the open position) is recorded if different than the dimension in this instruction book.

## AMH-4.76-VR Replacement Circuit Breaker

**Step 11:** After an adjustment is made, make sure that all nuts are secured in place, prior to returning to service.

### 5.3 MANUAL OPERATION CHECK

Manual operational checks must be performed before the breaker is connected to an energized circuit. Tests must be performed with the breaker withdrawn from the cell or in the disconnect position. While the breaker is withdrawn or in the disconnect position, place the maintenance tool into the manual charge socket opening and charge the closing springs with about 36 up and down strokes of the handle. When charging is complete, the closing crank goes over center with an audible “click” and the springs Charged / Discharged Indicator shows “Charged”. Remove the maintenance tool.

---

#### **⚠ NOTICE**

**IF THE SPRINGS ARE TO BE CHARGED ON A CLOSED BREAKER, NO CLICK IS HEARD AT THE END OF CHARGING OPERATION. DISCONTINUE CHARGING AND REMOVE THE MAINTENANCE TOOL AS SOON AS “CHARGED” FLAG IS FULLY VISIBLE. CONTINUE ATTEMPTS TO FURTHER CHARGE MAY RESULT IN DAMAGE TO THE MECHANISM.**

---

---

#### **⚠ WARNING**

**ALWAYS REMOVE THE MAINTENANCE TOOL AFTER CHARGING THE SPRING. FAILURE TO REMOVE THE MAINTENANCE TOOL FROM THE BREAKER COULD CAUSE INJURY TO PERSONNEL AND/OR EQUIPMENT DAMAGE IF THE BREAKER WAS TO CLOSE.**

---

Close and trip the breaker by pushing the close lever then the trip lever (Figure 3.3).

### 5.4 VACUUM INTERRUPTER INTEGRITY

Using a dry lint-free cloth or a paper towel, clean all the insulating surfaces of the pole units. Conduct a vacuum interrupter integrity check as described in Section 6.

### 5.5 LOW FREQUENCY WITHSTAND TEST (INSULATION CHECK)

Check breaker primary and secondary insulation per Section 6.

### 5.6 CONTACT EROSION AND WIPE

Manually charge the closing springs and close the breaker. Check contact erosion and wipe as described in Section 6.

### 5.7 PRIMARY CIRCUIT RESISTANCE

Check the primary circuit resistance as described in Section 6. The resistance should not exceed the values specified. Record the values obtained for future reference.

### 5.8 ELECTRICAL OPERATIONS CHECK

After going through the above steps, the breaker is now ready to be operated electrically. It is preferred that this check be made with the breaker in the Test position in the breaker compartment.

Since the Type AMH-4.76-VR Circuit Breaker is for use in existing AMH Metal-Clad Switchgear, installation procedures are similar. If it is necessary to reference anything in the breaker compartment, refer to the original instruction books supplied with the assembly.

---

#### **⚠ WARNING**

**EXAMINE THE INSIDE OF THE CELL BEFORE INSERTING THE BREAKER FOR EXCESSIVE DIRT OR ANYTHING THAT MIGHT INTERFERE WITH THE BREAKER TRAVEL.**

---

---

#### **⚠ WARNING**

**KEEP HANDS OFF THE TOP EDGE OF THE FRONT BARRIER WHEN PUSHING A BREAKER INTO A CELL. FAILURE TO DO SO COULD RESULT IN BODILY INJURY, IF FINGERS BECOME WEDGED BETWEEN THE BREAKER AND THE CELL. USE THE HANDLES PROVIDED ON THE FRONT OF THE BREAKER FACEPLATE, OR USE BOTH FULLY OPENED HANDS FLAT ON THE FRONT OF THE FACEPLATE.**

---

These checks can be performed with the breaker in its withdrawn or disconnect position and connecting the breaker to a test cabinet or to the switchgear cell's secondary receptacle using the special extension cable designed for this purpose and described in Section 3.

Perform electrical operations checks. Close and trip the circuit breaker electrically several times to verify that the operation is reliable and consistent. Check that the operation of the spring charging motor is reasonably prompt and that the motor makes no unusual noise.

---

#### **⚠ WARNING**

**DO NOT PERFORM ELECTRICAL OPERATION CHECKS WITH THE BREAKER IN THE “CONNECT” POSITION BECAUSE OF THE POSSIBILITY OF CONNECTING DE-ENERGIZED LOAD CIRCUITS TO THE ELECTRICAL POWER SOURCE, RESULTING IN DEATH, PERSONNEL INJURY OR EQUIPMENT**

---

Figure 5.2. AMH-VR in the Disconnect Position



## 5.9 DESCRIPTION OF OPERATIONAL POSITIONS

This section of the instructional manual covers the AMH line of Eaton vacuum replacement breakers. The AMH-4.76-VR has four basic operational positions:

- (1) Breaker withdrawn from the cell.
- (2) Breaker in the cell in the disconnect position. (Figure 5.2)
- (3) Breaker in the test position. (Figure 5.4)
- (4) Breaker in the connect position. (Figure 5.6)

## 5.10 INSERTION PROCEDURE

### **⚠ WARNING**

**ARC FLASH INCIDENTS WITH MV SWITCHGEAR CAN OCCUR DURING THE PROCESS OF INSERTING AND REMOVING POWER CIRCUIT BREAKERS IN SWITCHGEAR CUBICLES. IT IS STRONGLY RECOMMENDED THAT PROPER PPE (PERSONAL PROTECTIVE EQUIPMENT) BE WORN BY PERSONNEL WHO RACK BREAKERS USING THE MANUAL LEVERING HANDLE OR THE ROTARY RACKING HANDLE. EATON CORPORATION PROVIDES A UNIVERSAL REMOTE POWER RACKING SYSTEM (RPR-2) WHICH IS COMPATIBLE WITH THE INTERNAL ROTARY RACKING BREAKERS. THIS SYSTEM MAY ALLOW PERSONNEL TO WEAR A LOWER LEVEL OF PPE DURING THE INSERTION OR REMOVAL PROCESS AS LONG AS RACKING CAN BE PERFORMED FROM OUTSIDE THE FLASH PROTECTION BOUNDARY.**

- a. Place the breaker in the withdrawn position; verify the breaker position indicator indicates the breaker is in the “withdrawn” position.
- b. From the withdrawn position, align the guide bar of the breaker with the guide rails of the cell. (Figure 5.2)
- c. Check that the closing spring status indicator reads “DISCHARGED” and that the main contact status indicator reads “OPEN”.
- d. Push the circuit breaker into the cell until the mechanical stop is reached, this will be indicated by an audible click. At this point the side plunger has fallen into the front slot of the guide rail. In this position the breaker cannot be operated. Verify the breaker position indicator reads “disconnect”.
- e. To further advance the breaker into the cell, step on foot pedal, and open racking access shutter. (Figure 5.3) When racking nut is exposed, insert rotary racking handle and turn clockwise. The breaker will travel approximately 1.5 inches to reach the test position. (Figure 5.5) The breaker may be stopped in the test position, as indicated by the breaker and cell position decals, if electrical or mechanical testing is to be performed. Remove rotary racking handle before performing any testing.

**Figure 5.3. Advancing the AMH-VR Into the Cell**



**Figure 5.4. AMH-VR in the Test Position**



**Figure 5.5. Racking the AMH-VR Into the Cell**



### **⚠ NOTICE**

**ONCE THE SECONDARY DISCONNECT BLOCK IS ENGAGED IN THE “TEST” POSITION, IT WILL REMAIN CONNECTED THROUGHOUT FURTHER INWARD MOVEMENT AS THE BREAKER ADVANCES FROM THE “TEST” TO THE “CONNECT” POSITION.**

**THE SPRING CHARGING MOTOR WILL BEGIN TO RUN, IF THE MOTOR CUT-OFF SWITCH IS IN THE “ON” POSITION (FIGURE 3.4), AND CHARGE THE CLOSING SPRINGS AS THE SECONDARY CONNECTION IS MADE AS LONG AS CONTROL POWER IS AVAILABLE.**

- f. From the test position, the breaker can be advanced to the connect position by reinserting the rotary racking handle and stepping on the interlock pedal. Rotate racking handle clockwise until the connect position is reached and the handle can no longer be turned. This can be verified by the breaker position indicator. (Figure 5.6)

## AMH-4.76-VR Replacement Circuit Breaker

Figure 5.6. AMH-VR in the Connect Position



### 5.11 REMOVAL PROCEDURE

- a. To remove the breaker from the cell, it must be in the open position and the racking access handle in the top right slot; interlocking will prevent removal if the breaker is closed. Engage the rotary racking handle into the racking nut. Rotate the rotary racking handle counter-clockwise to move the breaker out of the cell. The shutters will start to close after the primary stabs have cleared, isolating the breaker from its source. Continue rotating racking handle counter-clockwise until the position indicators on the breaker and cell indicate test position. In test position the breaker can be operated either electrically or mechanically. Remove rotary racking handle before performing any testing.
- b. To further remove the breaker to the disconnect position continue turning the rotary racking handle in the counter-clockwise direction. If the breaker was inadvertently left charged in the test position, the springs will discharge as the breaker is racked to the disconnect position, resulting in a loud noise. The breaker will be in the disconnect position when the rotary racking handle can no longer be turned with normal force, and the breaker and cell position decals indicate disconnect position. At this point, the breaker will be open with the springs discharged.
- c. If the breaker is to be withdrawn, press the interlock pedal while pulling the breaker out of the cell using the handles on the front of the breaker. (Figure 3.3)

## SECTION 6: INSPECTION & MAINTENANCE

### WARNING

**DO NOT WORK ON A BREAKER IN THE "CONNECTED" POSITION.**

**DO NOT WORK ON A BREAKER WITH SECONDARY DISCONNECTS ENGAGED.**

**DO NOT WORK ON A BREAKER WITH SPRINGS CHARGED OR CONTACTS CLOSED.**

**DO NOT DEFEAT ANY SAFETY INTERLOCKS.**

**DO NOT LEAVE MAINTENANCE TOOL IN THE SOCKET AFTER CHARGING THE CLOSING SPRINGS.**

### WARNING

**STAND AT LEAST ONE METER AWAY FROM THE BREAKER WHEN TESTING FOR VACUUM INTEGRITY.**

**FAILURE TO FOLLOW ANY OF THESE INSTRUCTIONS MAY CAUSE DEATH, SERIOUS BODILY INJURY, OR PROPERTY DAMAGE. SEE SECTION 2 - SAFE PRACTICES FOR MORE INFORMATION.**

#### 6.1 INSPECTION FREQUENCY

Inspect the breaker once a year when operating in a clean, non corrosive environment. For a dusty and corrosive environment, inspection should be performed twice a year. Additionally, it is recommended to inspect the breaker every time it interrupts fault current.

**Note:** Refer to the table below for maintenance and inspection check points.

#### 6.2 INSPECTION AND MAINTENANCE PROCEDURES

NO. / SECTION	INSPECTION ITEM	CRITERIA	INSPECTION METHOD	CORRECTIVE ACTION IF NECESSARY	
1. Insulation	Stand Off Insulators, Operating Rods, Tie-Bars and Barriers	No Dirt	Visual Check	Clean With Lint-Free Cloth	
		No Cracking	Visual Check	Replace Cracked Unit	
	Vacuum Integrity	Between Main Circuit With Terminals Ungrounded	Withstand 27k 60Hz For 1 Minute	Hipot Tester	Clean And Retest Or Replace
	Insulation Integrity	Main Circuit To Ground	Withstand 15kV, 60Hz For 1 Minute (5kV Rating) 27kV, 60Hz For 1 Minute (15kV Ratings)	Hipot Tester	Clean And Retest Or Replace
Control Circuit To Ground (Charging Motor Disconnected)		Withstand 1125V, 60Hz For 1 Minute	Hipot Tester	Clean And Retest Or Replace	
2. Power Element	Vacuum Interrupters	Contact Erosion Visibility Of Mark	Visual - Close The Breaker And Look For Green Mark On Moving Stem From The Rear Of The Breaker (See Figure 6.1 and 6.2)	If Mark Is Not Visible, Replace Interrupter Assembly	
		Contact Wipe Visible	Visual (Figure 6.3 and 6.4)	Replace VI Assembly	
		Adequate Vacuum	See Section 6.3	Replace Interrupter Assembly If Vacuum Is Not Adequate	
		Dirt On Ceramic Body	Visual Check	Clean With Dry Lint-Free Cloth	
	Primary Disconnects	No Burning Or Damage	Visual Check	Replace If Burned, Damaged Or Eroded	
3. Control Circuit Parts	Closing And Tripping Devices Including Disconnects	Smooth And Correct Operation By Control Power	Test Closing And Tripping Of The Breaker Twice	Replace Any Defective Device-Identify Per Trouble-Shooting Chart	
	Wiring	Securely Tied In Proper Place	Visual Check	Repair Or Tie As Necessary	
	Terminals	Tight	Visual Check	Tighten Or Replace If Necessary	
	Motor	Smooth And Correct Operation By Control Power	Test Closing And Tripping Of The Breaker Twice	Replace Brushes Or Motor	
	Tightness Of Hardware	No Loose Or Missing Parts	Visual And Tightening With Appropriate Tools	Tighten Or Reinstall If Necessary	
4. Operating Mechanism	Dust Or Foreign Matter	No Dust Or Foreign Matter	Visual Check	Clean As Necessary	
	Lubrication	Smooth Operation And No Excessive Wear	Sight And Feel	Lubricate Very Sparingly With Light Machine Oil	
	Deformation Or Excessive Wear	No Excessive Deformation Or Wear	Visual And Operational	Remove Cause And Replace Parts	
	Manual Operation	Smooth Operation	Manual Charging Closing And Tripping	Correct Per Trouble-Shooting Chart If Necessary	
	CloSure™ Test	≥ 0.6 Inch Over Travel	CloSure™ Test 6.8.1	If < 0.6 Contact P.B.C. At 1-877-276-9379	

<b>BOLT SIZE</b>	8 - 32	10 - 32	.25 - 20	.31 - 18	.38 - 16	.50 - 13
<b>TORQUE Lb. In.</b>	24	36	72	144	300	540

# AMH-4.76-VR Replacement Circuit Breaker

## 6.3 VACUUM INTERRUPTER INTEGRITY TEST

Vacuum interrupters used in Type VR-Series circuit breakers are highly reliable interrupting elements. Satisfactory performance of these devices is dependent upon the integrity of the vacuum in the interrupter and the internal dielectric strength. Both of these parameters can be readily checked by a one minute AC high potential test. (See Table 6.1 for appropriate test voltage.) During this test, the following warning must be observed:

### **⚠ WARNING**

**APPLYING ABNORMALLY HIGH VOLTAGE ACROSS A PAIR OF CONTACTS IN VACUUM MAY PRODUCE X-RADIATION. THE RADIATION MAY INCREASE WITH THE INCREASE IN VOLTAGE AND/OR DECREASE IN CONTACT SPACING. X-RADIATION PRODUCED DURING THIS TEST WITH RECOMMENDED VOLTAGE AND NORMAL CONTACT SPACING IS EXTREMELY LOW AND WELL BELOW MAXIMUM PERMITTED BY STANDARDS. HOWEVER, AS A PRECAUTIONARY MEASURE AGAINST POSSIBILITY OF APPLICATION OF HIGHER THAN RECOMMENDED VOLTAGE AND/OR BELOW NORMAL CONTACT SPACING, IT IS RECOMMENDED THAT ALL OPERATING PERSONNEL STAND AT LEAST ONE METER AWAY IN FRONT OF THE BREAKER.**

With the breaker open and securely sitting on the floor, connect all top/front primary studs (bars) together and the high potential machine lead. Connect all bottom/rear studs together and the high potential return lead. Do not ground them to the breaker frame. Start the machine at zero potential, increase to appropriate test voltage and maintain for one minute.

Successful withstand indicates that all interrupters have satisfactory vacuum level. If there is a breakdown, the defective interrupter or interrupters should be identified by an individual test and replaced before placing the breaker in service.

After the high potential is removed, discharge any electrical charge that may be retained, particularly from the center shield of vacuum interrupters. To avoid any ambiguity in the AC high potential test due to leakage or displacement (capacitive) current, the test unit should have sufficient volt-ampere capacity. It is recommended that the equipment be capable of delivering 25 milliamperes for one minute.

Although an AC high potential test is recommended, a DC test may be performed if only a DC test unit is available, but is not recommended.

In this case the equipment must be capable of delivering 5 milliamperes for one minute to avoid ambiguity due to field emission or leakage currents and the test voltage shall be as shown in Table 6.1.

The current delivery capability of 25 mA AC and 5 mA DC apply when all three VI's are tested in parallel. If individual VI's are tested, current capability may be one third of these values.

### **⚠ WARNING**

**SOME DC HIGH POTENTIAL UNITS, OPERATING AS UNFILTERED HALF-WAVE RECTIFIERS, ARE NOT SUITABLE FOR USE TO TEST VACUUM INTERRUPTERS BECAUSE THE PEAK VOLTAGE APPEARING ACROSS THE INTERRUPTERS CAN BE SUBSTANTIALLY GREATER THAN THE VALUE READ ON THE METER.**

Breaker Rated Maximum Voltage	Vacuum Interrupter Integrity Test Voltage	
	AC 60Hz	DC
Up to and including 15.0 kV	27 kV	40 kV

## 6.4 CONTACT EROSION AND WIPE

Since the contacts are contained inside the interrupter, they remain clean and require no maintenance. However, during high current interruptions there may be a minimal amount of erosion from the contact surfaces. To determine contact erosion, close the breaker and observe the vacuum interrupter moving stem from the rear of the breaker. If the mark on each stem is visible, erosion has not reached maximum value thus indicating satisfactory contact surface of the interrupter. If the mark is not visible, the vacuum interrupter assembly must be replaced (Figure 6.1 and 6.2).

The adequacy of contact wipe can be determined by simply observing the vacuum interrupter side of the operating rod assembly on a closed breaker. Figures 6.3 and 6.4 show the procedure for determining the contact wipe. It maybe necessary to use a small mirror and flashlight to clearly see the "T" shape indicator. If the wipe is not adequate, the vacuum interrupter assembly (Pole Unit) must be replaced. Field adjustment is not possible.

### **⚠ WARNING**

**FAILURE TO REPLACE A VACUUM INTERRUPTER ASSEMBLY WHEN CONTACT EROSION MARK IS NOT VISIBLE OR WIPE IS UNSATISFACTORY, WILL CAUSE THE BREAKER TO FAIL TO INTERRUPT AND THEREBY CAUSE PROPERTY DAMAGE OR PERSONNEL INJURY.**

**Figure 6.1. Vacuum Interrupter Showing Contact Erosion Indicator With Breaker Open (Shown here for clarity purposes only)**



**Figure 6.2. Vacuum Interrupter Showing Contact Erosion Indicator With Breaker Closed (Indicators are checked only when breaker is closed.)**

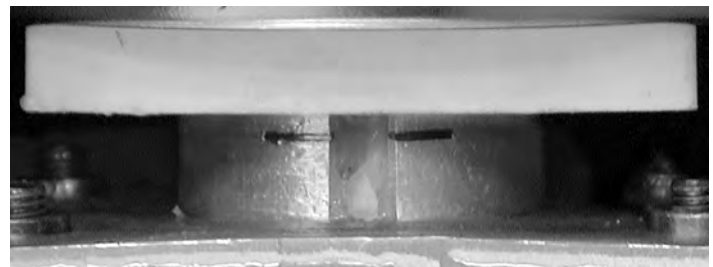



**Figure 6.3. The Arrow Shows The “T” Contact Wipe Indicator - Example with Blue Spring (If the “T” or any portion of its visible as shown with the breaker closed, the wipe is satisfactory) (See Next Figure for Graphic of All Possibilities)**



### 6.5 INSULATION

In VR-Series breakers, insulation maintenance primarily consists of keeping all insulating surfaces clean. This can be done by wiping off all insulating surfaces with a dry lint free cloth or dry paper towel. In case there is any tightly adhering dirt that will not come off by wiping, it can be removed with a mild solvent or distilled water. But be sure that the surfaces are dry before placing the breaker in service. If a solvent is required to cut dirt, use Isopropyl Alcohol or commercial equivalent. Secondary control wiring requires inspection for tightness of all connections and damage to insulation.

### 6.6 INSULATION INTEGRITY CHECK

#### PRIMARY CIRCUIT:

The integrity of primary insulation may be checked by the AC high potential test. The test voltage depends upon the maximum rated voltage of the breaker. For the breakers rated 4.76 kV, 8.25 kV and 15 kV the test voltages are 15 kV, 27 kV and 27 kV RMS, 60 Hz respectively. Conduct the test as follows:

Close the breaker. Connect the high potential lead of the test machine to one of the poles of the breaker. Connect the remaining poles and breaker frame to ground. Start the machine with output potential at zero and increase to the test voltage. Maintain the test voltage for one minute. Repeat for the remaining poles. Successful withstand indicates satisfactory insulation strength of the primary circuit.

Open the breaker. Connect the high potential lead of the test machine to one of the poles of the breaker. Connect the remaining poles and breaker frame to ground. Start the machine with output potential at zero and increase to the test voltage. Maintain the test voltage for one minute. Repeat for the remaining poles. Successful withstand indicates satisfactory insulation strength of the primary circuit.

If a DC high potential machine is used, make certain that the peak voltage does not exceed the peak of the corresponding AC RMS test voltage.

#### SECONDARY CIRCUIT:

Isolate the motor by disconnecting the two motor leads from the terminal block. Connect all points of the secondary disconnect pins with a shooting wire. Connect this wire to the high potential lead of the test machine. Ground the breaker frame. Starting with zero, increase the voltage to 1125 RMS, 60 Hz. Maintain the voltage for one minute. Successful withstand indicates satisfactory insulation strength of the secondary control circuit. Remove the shooting wire and reconnect the motor leads.

**Figure 6.4. Wipe Indication Procedure (Performed Only With Breaker Closed)**

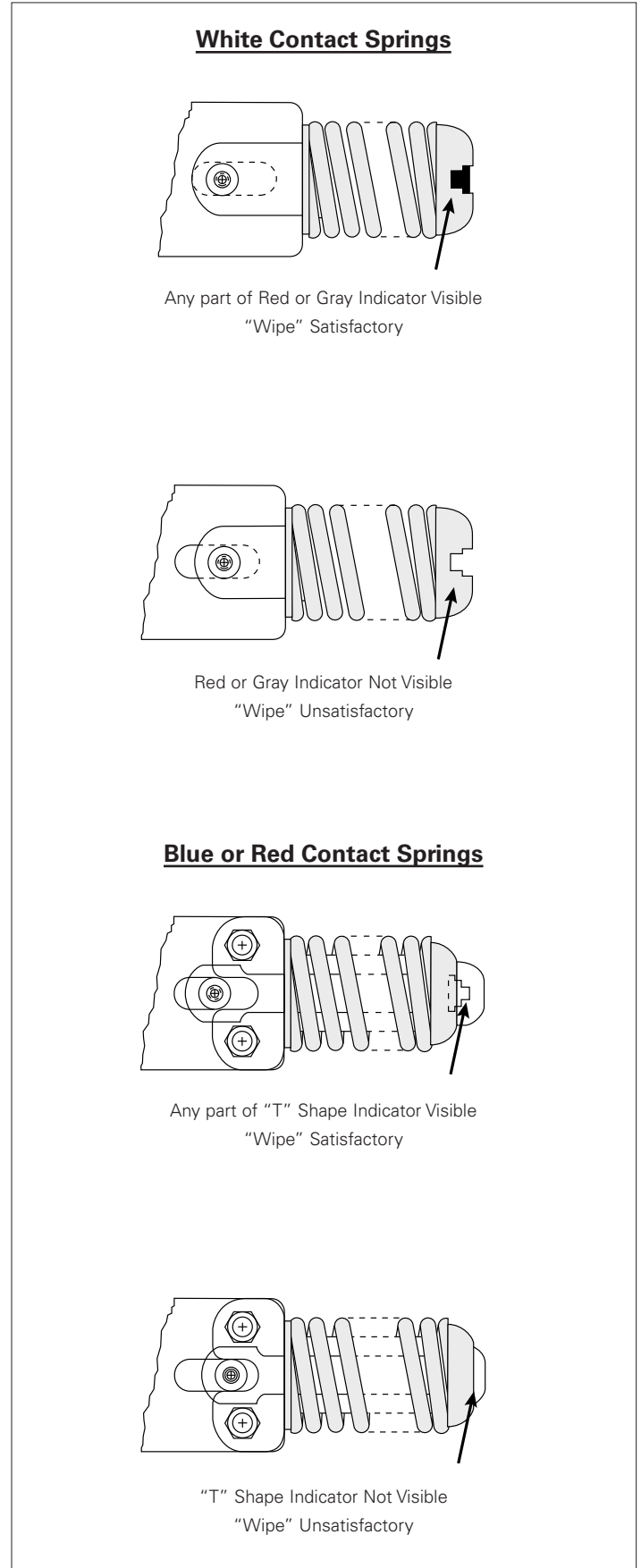

# AMH-4.76-VR Replacement Circuit Breaker

## 6.7 PRIMARY CIRCUIT RESISTANCE CHECK

The main contacts of the VR-Series circuit breaker are inside the vacuum chamber where they remain clean and require no maintenance at any time. Unlike most typical circuit breaker designs, the VR-Series design uses a highly reliable and unique flexible clamp design that eliminates the need for lubrication and inspection for wear.

The DC electrical resistance of the primary circuit may be calculated by measuring the voltage drop across the circuit. This test should be performed with a low voltage, direct current (DC) power supply capable of delivering no less 100A DC.

- To check the primary circuit resistance:
- Remove the circuit breaker from the switchgear
- Close the breaker
- Pass at least 100A DC from terminal to terminal of each pole unit in the closed position
- Measure the voltage drop across the terminals.

The resistance can be calculated from Ohm's Law and is expressed in micro-ohms. Repeat for the remaining two poles.

The resistance should not exceed the factory test levels more than 200%. Factory test levels are recorded on the circuit breaker test form, which is included with the breaker. If measurements exceeds 200%, contact the manufacturer.

### Resistance conversion for Temperature

$$R_{\text{conversion}} = R_{\text{Factory}}(1 + (T_{\text{Field}} - T_{\text{Factory}})\rho)$$

$R_{\text{conversion}}$  = Resistance correction for temperature based from the factory resistance measurement.

$R_{\text{Factory}}$  = Resistance measurement from the factory.

$T_{\text{Field}}$  = Temperature measurement in the field.

$T_{\text{Factory}}$  = Temperature measurement from the factory.

$\rho$  = Copper resistivity temperature coefficient.

$\rho$  = 0.0039 Copper Resistivity Temperature Coefficient / Deg C

$\rho$  = 0.002167 Copper Resistivity Temperature Coefficient / Deg F

## 6.8 MECHANISM CHECK

Make a careful visual inspection of the mechanism for any loose parts such as bolts, nuts, pins, rings, etc. Check for excessive wear or damage to the breaker components. Operate the breaker several times manually and electrically. Check the closing and opening times to verify that they are in accordance with the limits in Table 4.1.

### 6.8.1 CLOSURE™ TEST

**Introduction:** The CloSure™ Test is a simple yet extremely effective means to determine and monitor the ability of the mechanism to close the breaker contacts fully. It provides a quantitative measure of the extra energy available in terms of over travel in inches to close the breaker contacts to their full extent. It may be used periodically to monitor the health of the mechanism.

**General Information:** The CloSure™ Test can be performed on all VR-Series circuit breakers. (Refer to Table 6.1.) If the CloSure™ travel obtained is as specified, the mechanism performance is satisfactory. If the CloSure™ travel does not conform as shown in Figure 6.15, contact Eaton's Electrical Services & Systems for further information. (See Step 13).

### **⚠ WARNING**

**DO NOT ATTEMPT TO INSTALL OR PERFORM MAINTENANCE OR TESTS ON THE EQUIPMENT WHILE IT IS ENERGIZED. NEVER PUT YOUR HANDS NEAR THE MECHANISM WHEN THE CIRCUIT BREAKER IS IN THE CHARGED OR CLOSED POSITION. DEATH OR SEVERE PERSONAL INJURY CAN RESULT FROM CONTACT WITH ENERGIZED EQUIPMENT. ALWAYS VERIFY THAT NO VOLTAGE IS PRESENT BEFORE PROCEEDING WITH THE TASK, AND ALWAYS FOLLOW GENERALLY ACCEPTED SAFETY PROCEDURES.**

**Figure 6.5. Status Indicators ("A" shows the contact status indication and "B" shows the spring indication.)**

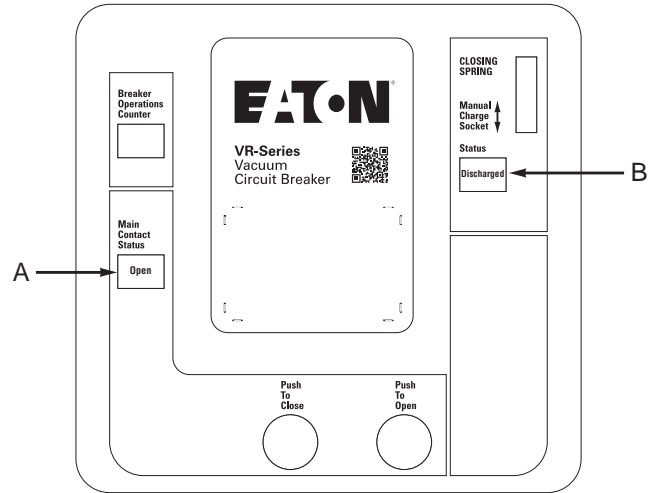

**Safety Precautions:** Read and understand these instructions before attempting any maintenance, repair or testing on the breaker. The user is cautioned to observe all recommendations, warnings and cautions relating to the safety of personnel and equipment.

The recommendations and information contained herein are based on Eaton Electrical experience and judgment, but should not be considered to be all-inclusive or covering every application or circumstance which may arise. If further information is required, you should consult Eaton's Electrical Services & Systems.

**Testing Procedures:** Assuming that the circuit breaker is safely removed from the switchgear enclosure and positioned in an area outside the arc fault boundary, follow this procedure to perform the CloSure™ test. For further instructions on removal of the circuit breaker from the switchgear, refer to the appropriate section of this manual.

**Step 1 -** On the front cover, identify the status indicators. Make sure the closing spring status indicates "DISCHARGED" and the main contact indicator shows "OPEN" (Figure 6.5).

**Step 2 -** Remove the circuit breaker front cover. Be sure to save the original fasteners for reassembly.

**Step 3 -** Charge the circuit breaker, close the circuit breaker, then open the circuit breaker. Alternately depress the Open and Close clappers a few times to ensure the circuit breaker is completely discharged.

**Step 4 -** Cut a piece of one inch wide drafting / masking tape approximately 8 to 10 inches long.

**Figure 6.6. Wrapping Tape Around Cam**



- Step 5** - Clean the far left cam with a mild solvent such as alcohol. Place the tape around the cam starting from the bottom up. Make certain that the tape adheres well to the cam surface. (Figure 6.6).
- Step 6** - Mount the transparent CloSure™ Test Tool (Figure 6.7b) with two bolts and washers. Refer to Figure 6.7a and Table 6.1 for approximate mounting holes. Hand tighten the bolts.
- Step 7** - Using a red Sanford® Sharpie® fine point permanent marker (or equivalent), place the marker tip in the proper hole ("C") located over the cam and make a heavy mark on the tape by moving the marker as described in Figures 6.9, 6.11, and 6.12. Remove the marker from the hole.
- Step 8** - Charge the closing springs with the maintenance tool (Charging handle). Continue charging the closing springs until a "click" is heard and the status indicator shows "CHARGED" (Figure 6.8).
- Step 9** - Place the marker back in the hole. While holding the marker tip against the tape, close the breaker (Figure 6.10). Remove the marker from the hole.
- Step 10** - While closely observing the pole shaft at the right side of the circuit breaker (Figure 6.11), recharge the closing springs with the maintenance tool. As the circuit breaker is recharged, there should be no movement of the pole shaft. If there is movement of the pole shaft while recharging, this indicates a problem with the circuit breaker - stop the test and consult the factory.
- Step 11** - Open the circuit breaker, then close it, then reopen it. Verify that the mark made in Step 7 is aligned with the pen opening. If it is not aligned, this indicates a problem with the circuit breaker - stop the test and consult the factory.
- Step 12** - Inspect the circuit breaker to assure it is in the open position and the closing springs are discharged. Alternately depress the Open and Close clappers a few times to ensure the circuit breaker is completely discharged. Remove the transparent CloSure™ Tool.
- Step 13** - Remove the tape from the cam and place it on a sheet of paper that can be kept as a record of the test. Record the date of the test, person conducting the test, circuit breaker serial number, and the operations counter on the tape or paper (Figures 6.14 and 6.15).
- Step 14** - Evaluate the CloSure™ performance by comparing the test tape with the illustration in Figure 6.16. Measure the over travel "X". If "X" is not greater than or equal to 0.6", this indicates a problem with the circuit breaker - consult the factory.
- Step 15** - Reassemble the front cover onto the circuit breaker. Return the circuit breaker to its original configuration and setup.

**Figure 6.7. Attaching CloSure™ Test Tool at Hole "A" & "B"**

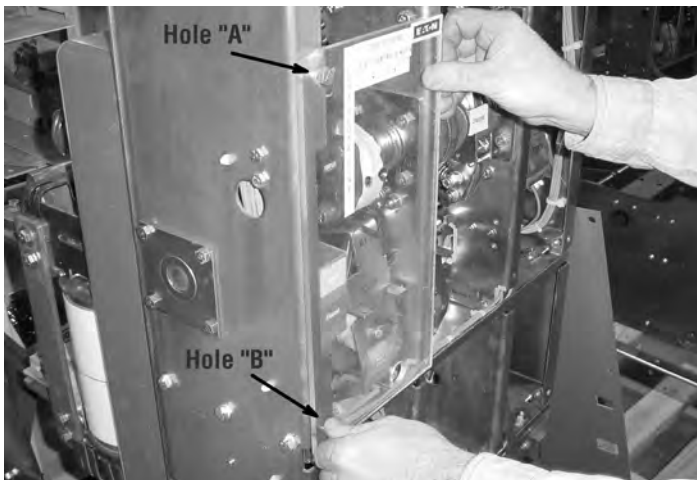

**Figure 6.7.b. Front View of CloSure™ Tool Showing Mounting / Testing Hole Locations (6352C49H01)**

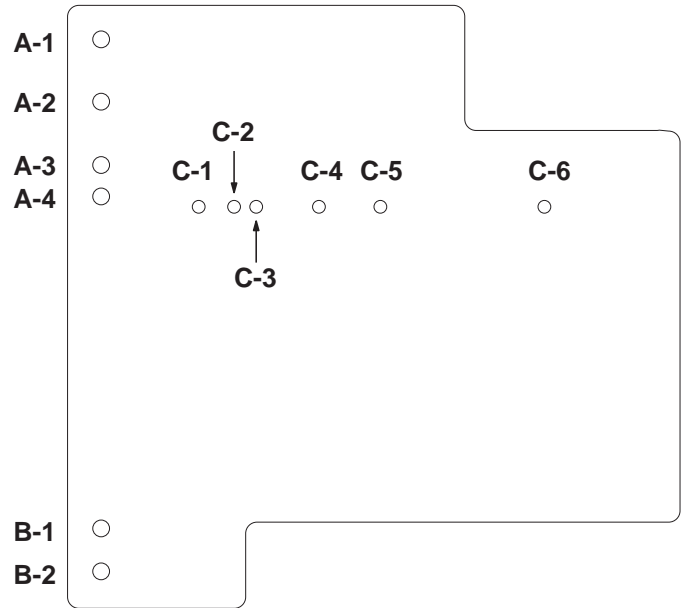

**Table 6.1. CloSure™ Tool Mounting / Testing Locations by Circuit Breaker Type**

ELEMENT DESIGNATION	APPROXIMATE MECHANISM CHASSIS WIDTH (INCH)	UPPER MOUNTING HOLE	LOWER MOUNTING HOLE	MARKER PLACEMENT HOLE
18WR	18	A1	B2	C1
20WR	20	A1	B2	C2
29WR	27	A1	B2	C5

**Figure 6.7.c. Typical Circuit Breaker Front View with CloSure™ Tool Attached (Approximate Mechanism Chassis Width)**

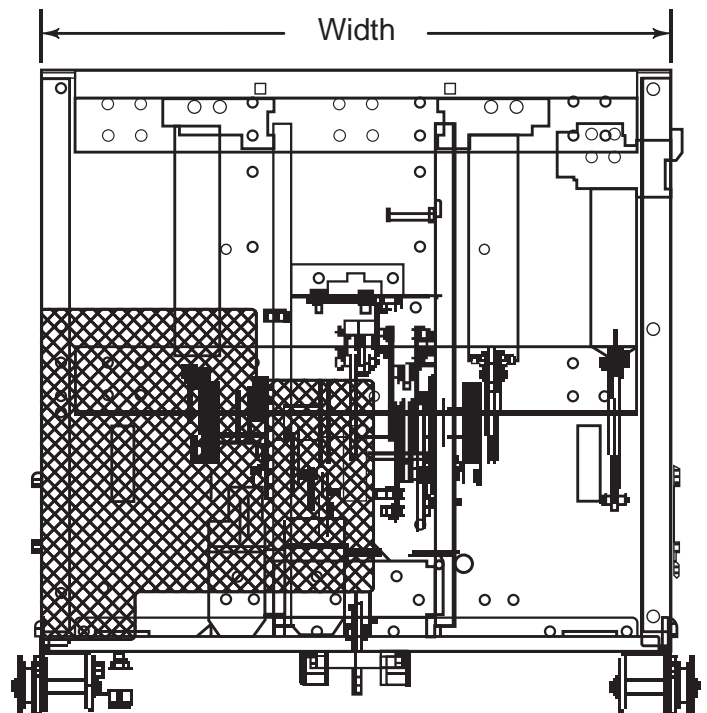

Figure 6.8. Manually Charging Closing Springs

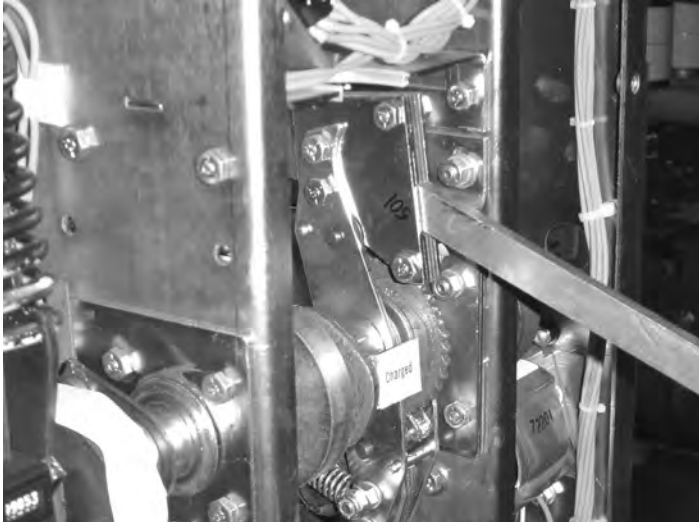

Figure 6.9. Make a Clear and Heavy Mark



Figure 6.10. With Marker in Hole "C", While Closing Breaker



Figure 6.11. Pole Shaft Located On Right Side Of Circuit Breaker

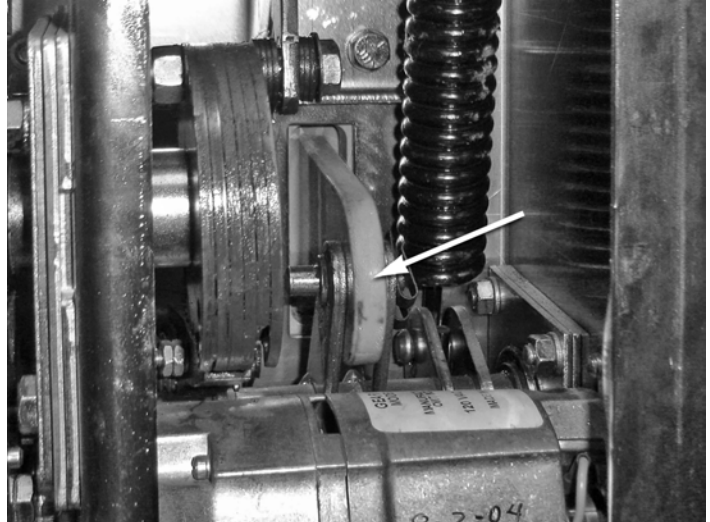

Figure 6.12. Move the Sharpie® 15° Left and Right



Figure 6.13. Top view of Cam and Marker Interface

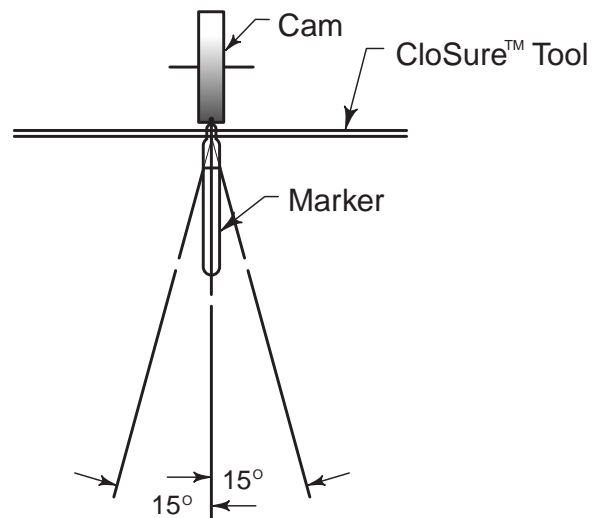

Figure 6.14. Evaluate the CloSure™ Performance

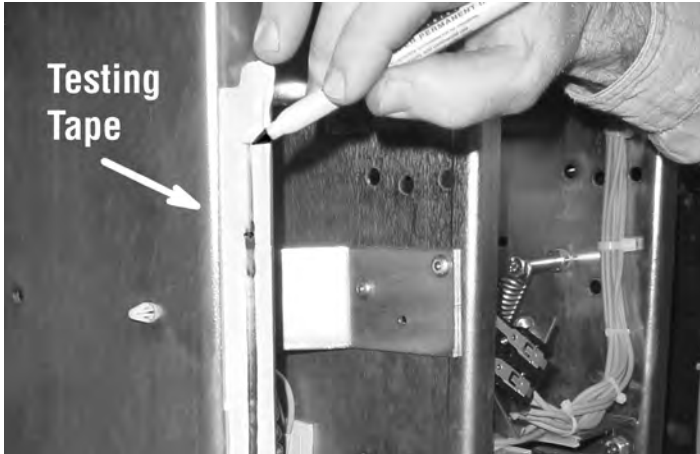
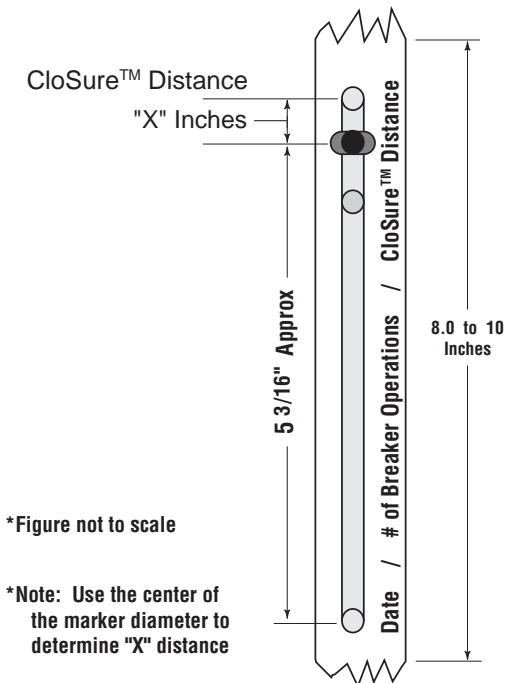

Figure 6.15. Determining the Distance Traveled



Figure 6.16. Illustrative Testing Tape Sample



## 6.9 LUBRICATION

All parts that require lubrication have been lubricated during the assembly with molybdenum disulphide grease. Eaton No. 53701QB. Over a period of time, this lubricant may be pushed out of the way or degrade. Proper lubrication at regular intervals is essential for maintaining the reliable performance of the mechanism. **The breaker should be relubricated once a year or per the operations table (Table 6.2), which ever comes first.** The locations shown in Figure 6.17 should be lubricated with a drop of light machine oil.

After lubrication, operate the breaker several times manually and electrically.

Roller bearings are used on the pole shaft, the cam shaft, the main link and the motor eccentric. These bearings are packed at the factory with a top grade slow oxidizing grease which normally should be effective for many years. They should not be disturbed unless there is definite evidence of sluggishness, dirt or parts are dismantled for some reason.

If it becomes necessary to disassemble the mechanism, the bearings and related parts should be thoroughly cleaned, remove old grease in a good grease solvent. Do not use carbon tetrachloride. They should then be washed in light machine oil until the cleaner is removed. After the oil has been drawn off, the bearings should be packed with Eaton Grease 53701 QB or equivalent.

Table 6.2. Lubrication Per Number of Operations

RATINGS	OPERATIONS
29kA and below	750
Above 29kA	400
3000 Amp	400

Figure 6.17. General Lubrication Areas

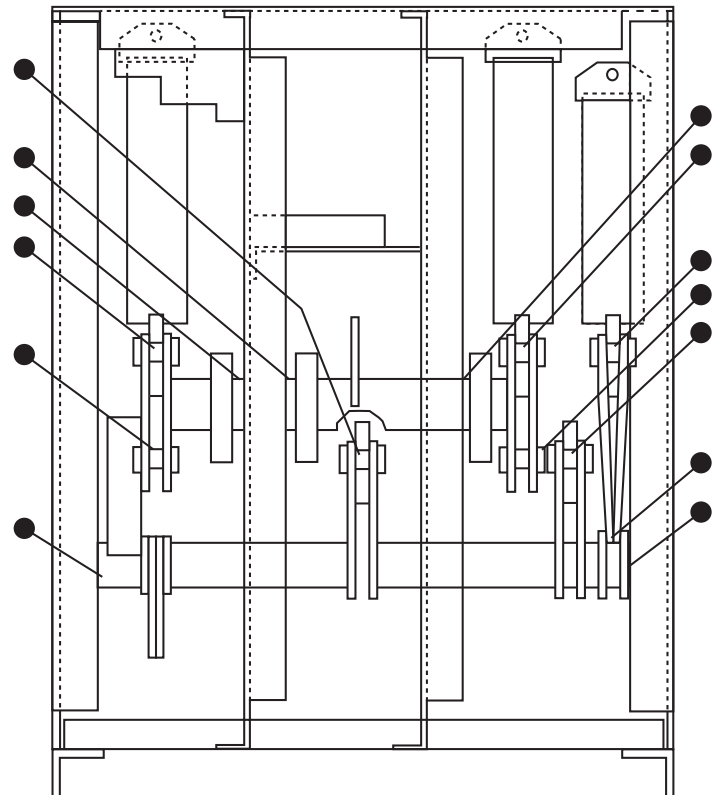

● Apply one drop of non-synthetic light machine oil at locations shown.

# AMH-4.76-VR Replacement Circuit Breaker

**Table 6.3. Troubleshooting Chart**

SYMPTOM	INSPECTION AREA	PROBABLE DEFECTS
<b>FAILS TO CLOSE</b>		
Closing Springs Not Charged	Control Circuit	<ul style="list-style-type: none"> <li>Control Power (Fuse Blown Or Switch Off)</li> <li>Secondary Disconnects</li> <li>Motor Cut-off Switch (Poor Or Burned Contacts. Lever Not Operational.)</li> <li>Terminals And Connectors (Poor Or Burned Contacts)</li> <li>Motor (Brushes Worn Or Commutator Segment Open)</li> </ul>
	Mechanism	<ul style="list-style-type: none"> <li>Pawls (Slipping Or Broken)</li> <li>Ratchet Wheel (Teeth Worn Or Broken)</li> <li>Cam Shaft Assembly (Sluggish Or Jammed)</li> <li>Oscillator (Reset Spring Off Or Broken)</li> </ul>
Closing Springs Not Charged Breaker Does Not Close	Control Circuit (Close Coil Does Not Pick Up)	<ul style="list-style-type: none"> <li>Control Power (Fuse blown or switch off)</li> <li>Secondary Disconnects</li> <li>Anti Pump Relay (Y Relay N.C. Contact Open Or Burned Or Relay Picks Up)</li> <li>Close Coil (Open Or Burned)</li> <li>Latch Check Switch (Contact Open - Bad Switch Or Trip Bar Not Reset)</li> <li>Auxiliary Switch (B Contact Open Or Burned)</li> <li>Motor Cut-Off (Contacts Open Or Burned)</li> <li>Trip Coil Assembly (Clapper Fails To Reset)</li> </ul>
	Closing Sound But No Close	<ul style="list-style-type: none"> <li>Pole Shaft (Not Open Fully)</li> <li>Trip Latch Reset Spring (Damaged Or Missing)</li> <li>Trip Bar-D Shaft (Fail To Remain Reset)</li> <li>Trip Latch-Hatchet (Fails To Remain Reset)</li> <li>Trip Floor Tripper (Fails To Remain Reset)</li> <li>Close Latch (Binding)</li> <li>Close Latch Roller (Binding)</li> <li>Trip Circuit Energized</li> </ul>
<b>UNDESIRABLY CLOSES</b>		
	Control Circuit	<ul style="list-style-type: none"> <li>Close Circuit (CS/C Getting shorted)</li> </ul>
	Mechanism	<ul style="list-style-type: none"> <li>Close Release Latch (Fails To Reset)</li> <li>Close Floor Tripper (Fails To Reset)</li> </ul>
<b>FAILS TO CLOSE</b>		
No Trip Sound	Control Circuit	<ul style="list-style-type: none"> <li>Control Power (Fuse Blown Or Switch Off)</li> <li>Secondary Disconnects</li> <li>Auxiliary Switch (A Contact Not Making Poor Or Burned)</li> <li>Trip Coil (Burned Or Open)</li> <li>Terminals And Connections (Poor Or Burned Or Open)</li> <li>Trip Clapper (Jammed)</li> </ul>
	Trip Mechanism	
Trip Sound But No Trip	Trip Mechanism	<ul style="list-style-type: none"> <li>Trip Bar, Trip Latch (Jammed)</li> <li>Pole Shaft (Jammed)</li> <li>Operating Rod Assembly (Broken Or Pins Out)</li> </ul>
	Vacuum Interrupter (One Or More Welded)	
<b>UNDESIRABLY TRIPS</b>		
	Control Circuit	<ul style="list-style-type: none"> <li>Control Power (CS/T Switch, remains made)</li> </ul>
	Mechanism	<ul style="list-style-type: none"> <li>Trip Coil Clapper (Not Resetting)</li> <li>Trip Bar or Trip Latch (Poor Engagement Of Mating Or Worm Surfaces)</li> <li>Trip Bar Reset Sprint (Loss Of Torque)</li> </ul>

## SECTION 7: REPLACEMENT PARTS











### 7.1 GENERAL

In order to minimize production downtime, it is recommended that an adequate quantity of spare parts be carried in stock. The quantity will vary from customer to customer, depending upon the service severity and continuity requirements. Each customer should develop his own level based on operating experience. However, when establishing a new operating record, it is a good practice to stock one set of control components for every six circuit breakers of the same control voltage. This quantity should be adjusted with time and frequency of operation of the circuit breakers.

### 7.2 ORDERING INSTRUCTIONS

- The style numbers in Table 7.1 should be sufficient to purchase control components for most applications. Some breakers have special control schemes. Supply complete nameplate information for verification or if additional components are needed.
- Specify the method of shipping desired.
- Send all orders or correspondence to the nearest Eaton sales office or contact the PBC direct at 1-877-276-9379.
- Include negotiation number with order when applicable.

**Table 7.1 Common Replacement Parts - Descriptions and Style Numbers**

1.	ANTI-PUMP (Y) RELAY	(48vDC) (125vDC) (250vDC) (120vAC) (240vAC)	94C9525H01 94C9525H02 94C9525H03 94C9525H04 94C9525H05	6.	BREAKER POSITION SWITCH	Breaker Position Switch PS2	94C9525H07
							
2.	RECTIFIER	Rectifier	94C9525G09	7.	LATCH CHECK SWITCH	Latch Check Switch (LC)	94C9525H08
							
3.	SPRING CHARGING MOTOR	(48vDC) (125vDC) (250vDC / 240vAC)	94C9525G10 94C9525G11 94C9525G12	8.	MOTOR CUTOFF SWITCHES	(LS) (20WR/29WR) (LS) (18WR)	94C9525G14 94C9525G15
							
4.	BREAKER AUXILIARY SWITCH	Breaker Auxiliary Switch	94C9525G13	9.	SPRING RELEASE COILS / SHUNT TRIPS	24vDC 48vDC 125vDC / 120vAC 250vDC / 240vAC	94C9525G16 94C9525G17 94C9525G18 94C9525G19
							
5.	BREAKER POSITION SWITCH	Breaker Position Switch PS1	94C9525H06	10.	CONTROL COMPONENTS KIT	48vDC 125vDC 250vDC 120vAC-C/M 48vDC-T 240vAC-C/M 48vDC-T 120vAC-C/M 120vAC-CT 240vAC-C/M 240vAC-CT	94C9525G01 94C9525G02 94C9525G03 94C9525G04 94C9525G05 94C9525G06 94C9525G07
							



**Eaton**  
1000 Eaton Boulevard  
Cleveland, OH 44122  
United States  
Eaton.com

© 2013 Eaton  
All Rights Reserved  
Printed in USA  
Publication No. IB182023EN  
March 2016

Eaton is a registered trademark.

All trademarks are property  
of their respective owners.