

# GROUNDING AND GROUND FAULT PROTECTION OF MULTIPLE GENERATOR INSTALLATIONS ON MEDIUM-VOLTAGE INDUSTRIAL AND COMMERCIAL POWER SYSTEMS

## PART 2: GROUNDING METHODS

An IEEE/IAS Working Group Report

[Working Group Members] - Prafulla Pillai (Chair), Alan Pierce, Bruce Bailey, Bruce Douglas, Charles Mozina, Clifford Normand, Daniel Love, David Shipp, Gerald Dalke, James R. Jones, Jay Fischer, Jim Bowen, Lorraine Padden, Louie Powell, Neil Nichols, Ralph Young, Norman T. Stringer

Working Group Chair:  
Prafulla Pillai  
Kellogg Brown & Root, Inc.  
Houston, Texas 77002

**Abstract** - The paper discusses typical grounding practices and ground fault protection methods for medium voltage generator stators, highlighting their merits and drawbacks. Particular attention is given to applications of multiple generators connected to a single bus. The paper also provides an overview of the generator damage mechanism during stator ground faults. Problem areas associated with each method of grounding are identified and solutions are discussed. The paper also provides a list of references on the topic. The paper is intended as a guide to aid engineers in selecting adequate grounding and ground fault protection schemes for medium voltage industrial and commercial generators for new installations, for evaluating existing systems, and for future expansion of facilities, to minimize generator damage from stator ground faults. These topics are presented in four separate parts, Part 1 through Part 4. Part 1 covers scope, introduction, user examples of stator ground failure, and theoretical basis for the problem. Part 2 discusses various grounding methods used in industrial applications. Part 3 describes protection methods for the various types of grounding and Part 4 provides a conclusion and bibliography of additional resource material.

### I. GENERAL

There are several methods of power system grounding. These include low-resistance grounded (LRG), effectively grounded, reactance grounded, high-resistance grounded (HRG), and ungrounded. Source grounding may be accomplished by the grounding of the generator(s) and/or power transformer(s). Grounding transformers may be utilized in lieu of source grounding. A brief overview of each of these grounding methods is given below.

### II. LOW-RESISTANCE GROUNDED SYSTEM

In low-resistance grounding of the source generator, the generator neutral is connected to ground through a resistor, as shown in Fig. 1, Part 1. The resistor limits the ground fault current to several hundred amperes (typically 200 – 600 A). The fault current is selected to minimize fault damage but at the same time allow sufficient current for selective tripping of the protective devices. The lower limit was historically based on electro-mechanical relay sensitivity and the upper limit is based on resistor losses during a ground fault and damage to cable shields.

With multiple sources, the total ground fault current can be very high. Low-resistance grounding is generally used for generators connected to a common bus where relaying selective with feeder relaying is required. For bus-connected generators operated in parallel with transformers, connecting the wye-connected winding of the transformer to the generator bus would allow the transformer neutral to provide one ground when the generator is out of service.

There are many advantages which can be attained by using low-resistance grounding. These include sufficient fault current magnitudes to allow sensitive and selective relaying with feeders and bus-tie breakers, easy inclusion of additional sources, limitation of transient overvoltages to moderate values, and potential cost savings over other grounding methods.

There are some disadvantages associated with low-resistance grounding. The main disadvantage is the possibility of significant burning of the generator stator iron laminations from high ground fault currents, as explained in Part 1. Also, with multiple ground sources, high currents due to parallel sources can cause severe fault damage, and large variations

of available fault current can cause relay coordination problems. Consideration should be given to selecting appropriate surge arresters for the grounding method.

For a system with multiple sources, some of the variations in the low-resistance grounding method are discussed below.

#### **a) Single Point Grounding**

Single point grounding requires that only one source be grounded at any given time. This is the simplest method of low-resistance grounding. Since there is only one ground source, it provides lower ground fault current than with multiple point grounding. Also, relay coordination is simple since there is no variation in ground current. In addition, third-harmonic circulating currents are eliminated.

The principle disadvantage of single point grounding is that if the grounded power source is out of service, the system will operate ungrounded unless an alternate ground is established. This requires special operating procedures. Grounding the system neutral through a neutral deriving transformer on the bus is an effective means of overcoming this disadvantage.

#### **b) Multiple Point Grounding**

In this method, the neutrals of individual sources (transformers and generators) are each grounded through a separate resistor with ground fault current from each source limited to the selected value. Multiple point grounding offers simplified operation and is most commonly used with low-resistance grounding, assuring that the system will always be grounded. However, resistor selection can be difficult.

When several sources are paralleled, the total ground fault current can increase to high values, causing severe fault damage. In such cases, the grounding resistance should be high enough to limit the fault current to a safe value when all of the parallel sources are in service, and should be low enough so that when source(s) are removed, sufficient fault current flows for relay operation.

Addition or removal of parallel sources causes wide variations in fault current and makes relay coordination difficult. Another problem is that the parallel paths to ground introduce the possibility of circulating third harmonic currents, which can cause overheating of the generators at less than full load.

#### **c) Common Ground with Neutral Switching (not Recommended):**

Here, each source is connected to a common neutral point through a switching device and the neutral point is grounded through the low resistance. The advantages include low ground fault current due to single ground, known maximum ground current, minimizing of the problems of varying ground current with addition or removal of generators, and simplified relay coordination. This is a previously adopted

method but no longer being used due to safety issues as explained below.

There are several disadvantages with this method of grounding. The most significant is a safety issue i.e., attempting to switch the neutral at the same instant a ground fault occurs could be extremely hazardous to operating personnel, unless adequate switching devices and safety precautions are provided. Also, cost is increased due to the need for several neutral switches or circuit breakers. In addition, unless a key-interlock system is used, special operating procedures are required to close another operating ground point prior to taking the first one out. This may introduce operator errors causing ungrounded operation.

All ground sources should be in close proximity in order to allow quick interchanging of neutral switching operations, to minimize conductor length of neutral bus connection for effective grounding, and to avoid inadvertent opening of interconnection thereby preventing ungrounded operation. If the neutral is left connected when a generator is taken out of service, all the phase voltages will be elevated in magnitude during a ground fault. Also, there is a possibility of accidental contact with an energized bus that leads to the ground bus.

For these reasons, the practice of employing a common ground with neutral switching should be avoided.

### **III. EFFECTIVELY GROUNDED SYSTEM**

For effectively grounded systems, the neutral is connected to ground through a sufficiently low impedance, intentionally inserted such that the ratio  $X_0/X_1$  is positive and less than 3, and the ratio  $R_0/X_1$  is positive and less than 1. These specific criteria are to limit the build-up of voltages in excess of limits established for apparatus, circuits, or systems so grounded. "Solidly grounded" systems have no impedance inserted intentionally between neutral and ground.

Since the natural zero sequence impedance of a synchronous generator is typically about half the subtransient positive sequence reactance, the ground fault current that wants to flow from a solidly grounded generator is greater than the three-phase fault current. However, NEMA standards [1] do not require that standard generators be braced for the mechanical stresses associated with unbalanced fault currents in excess of the magnitude of a three-phase fault at the terminals of the generator. Therefore, the neutrals of standard generators should not be connected to ground without some limiting impedance.

There are, however, instances in which the generator will be applied on 4-wire systems. Low-voltage emergency generators are typically designed with sufficient bracing to permit them to be solidly grounded, but medium-voltage generators almost always must have impedance inserted into the neutral to limit the ground fault current through the generator to less than the bolted three-phase magnitude.

#### IV. REACTANCE GROUNDED SYSTEM

Low-reactance grounding of generators is normally reserved for special applications such as those unusual instances in which the generator is connected to a bus that serves distribution loads directly at the generator terminal voltage, and where some of the loads on the distribution feeders are single-phase and connected phase-to-ground. In this special case, natural unbalances between the loads on an individual phase results in a current flow through the generator neutral. Any significant impedance between the generator neutral and ground would inhibit this current flow and thereby interfere with the ability of the generator to serve this unbalanced load. Therefore, there is a need to minimize any neutral impedance in these applications.

At the same time, NEMA standard generators cannot be effectively grounded for reasons described above [1]. These opposing objectives can be satisfied by a compromise minimum selection criterion for a generator neutral grounding reactor. That minimum reactor is one that will limit the available phase-to-ground fault current to no greater than the available three-phase fault current. In addition, generator grounding reactors must have a short time current rating sufficient for the available magnitude of phase-to-ground fault current. Standards provide for a minimum continuous thermal capability of a neutral grounding reactor equal to 10% of the short-time current rating of the reactor [2]. One of the checks that the application engineer must make is to verify that this continuous capability is sufficient for the maximum anticipated unbalanced load current.

A more challenging problem in applying neutral grounding reactors is that generators do not produce a perfectly smooth sinusoid of voltage, and any triplen harmonic content in this voltage will result in a circulating harmonic current. In most cases, the third harmonic is of concern. It is necessary to predict by some means the magnitude of harmonic voltage produced by each generator on the system in order to determine the worst-case circulating current. This is necessary to verify that the reactor has sufficient thermal capacity to withstand this current [3]. Fortunately this problem is not frequently encountered. If the problem does occur it can be prevented by the use of a 2/3 pitch winding for the generator.

Reactance grounding based on limiting the phase-to-ground fault current to the level of the three-phase fault current generally does not result in protection problems because there is ample fault current to be detected by conventional relays. In fact, a common problem is the presence of unbalanced load current that may limit the ability to employ traditional ground relays to measure residual current.

One little-known practice that is still used in some areas is to apply high-inductance neutral grounding reactors on unit-connected generators. These "Petersen Coil" or ground-

fault neutralizers are selected with an inductance to match the magnitude of distributed zero sequence capacitance in the generator and the bus work up to the delta-connected generator step-up transformer winding. The advantage of this application is that fault current will be negligibly small for a system phase-to-ground fault compared to other methods [4, 5, 6].

However, it should be noted that this practice has its own problems. When the current associated with single-phase-to-ground faults is limited by neutral impedance, the consequence is that the voltage triangle shifts and there is a sustained overvoltage on the unfaulted phases. If this voltage stress is not relieved, it can accelerate insulation failure.

To be effective, the inductance of Petersen Coils must be tuned to the distributed capacitance in the system. This sometimes presents insurmountable problems in instances in which switching causes the distributed capacitance to change with various operating conditions of the system.

#### V. HIGH-RESISTANCE GROUNDED SYSTEM

A key advantage of high-resistance grounding is that transient overvoltages can be substantially reduced from that present on an ungrounded system.

##### a) System High-resistance Grounding

In high-resistance grounding, the ground current magnitude is typically limited to 10 A or less, a value equal to the normal maximum charging current magnitude for an industrial power system. Industry practice through the years has shown that ground fault currents limited to less than 10 A produce minimal damage at the fault point. Therefore, the faulted circuit need not be tripped off-line immediately when the fault first occurs. This low level of ground current requires protection schemes that are especially developed for unit-connected high-resistance grounded generators. However, if significantly greater ground fault currents are allowed to flow continuously, then unacceptable damage is sustained. For systems rated 11kV or higher, practice requires tripping due to arcing effects at this voltage.

##### b) Generator High-resistance Grounding

When a generator is connected to the plant distribution bus at the medium voltage level, high-resistance grounding can be a good solution for grounding the generator neutral. The generator can be high-resistance grounded regardless of the grounding method used to ground the system. While high-resistance grounding is a good choice for minimizing damage to a generator, it does not lend itself to large systems where it may not be possible to keep ground fault currents to less than 10 A. Particular attention should be given such that all system components should be rated for continuous duty at line-to-line voltage, including cable and voltage transformers. Another aspect of high-resistance grounding is that corona starts playing a significant part towards damage

for systems with line-to-line voltages greater than about 7.2 kV, if continuous duty is desired (i.e., continue operating indefinitely under ground fault conditions).

### c) Unit-Connected Generator Grounding

High-resistance grounding of a generator neutral is illustrated in Fig. 11. Even though this method of grounding is typically utilized on unit-connected generators, it is gaining acceptance in the industrial arena. This scheme can be economically attractive since it allows the generator to have the optimum voltage for its size.

High-resistance grounding of the generator utilizes a distribution transformer with a primary voltage rating greater than or equal to the line-to-neutral voltage rating of the generator and a secondary rating of 120V or 240V. The distribution transformer should have sufficient overvoltage capability so that it does not saturate on single-line-to-ground (SLG) faults with the generator operated at 105% of rated voltage. The secondary resistor is usually selected so that for a SLG fault at the terminals of the generator, the power dissipated in the resistor is approximately equal to the reactive volt-amperes of the zero sequence capacitive reactance of the generator windings, its leads, the windings of any transformers connected to the generator terminals, and any surge capacitors installed in this area.

For high-resistance grounding to be effective, the size of the resistor must be carefully selected for each system [7]. IEEE Standard C37.101 [8] provides a detailed example of how to determine the size of the ground resistor to meet the requirements cited above, as well as calculate the resulting ground currents and voltages. Under ground fault conditions, the resistive current must dominate over the system capacitive current but not to the point of permitting excessive current to flow and thereby, excluding continuous operation.

## VI. UNGROUNDED SYSTEM

A close look at all the electrical parameters in the following ungrounded system example, will illustrate the effect grounding has on current and voltage under "bolted" ground fault conditions.

In Fig. 12, a sustained ground fault occurs on a 4.16 kV ungrounded system. Fig. 13a illustrates the system voltage profile prior to the ground fault condition. Since the system is capacitively coupled to ground through relatively high impedance, a phase-to-ground fault causes the entire system to be displaced above ground as indicated in Fig. 13b. The system will remain in this position until the fault is cleared, or another phase breaks down to form a phase-to-ground-to-phase fault.

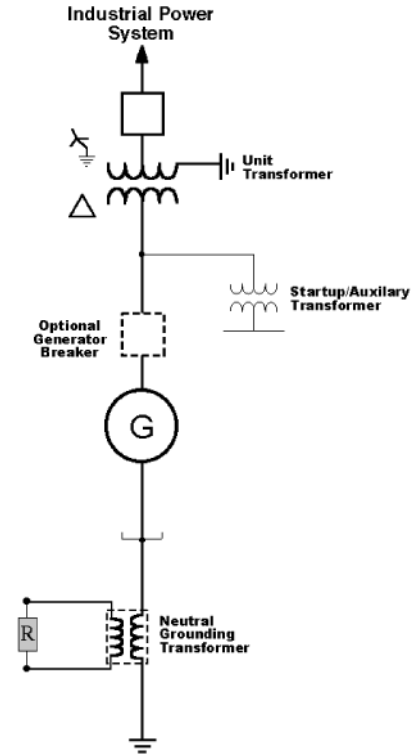

Fig. 11. High-Resistance Grounding of Unit-Connected Generator Configuration

As shown in Fig. 12, the ground fault current returns through the distributed capacitance (insulation system) of the unfaulted phases. As indicated, only 5.2 A will flow. The dashed lines in Fig. 13 represent the phase-to-phase voltage relationship so that a delta system can also be visualized.

$$|I_{A(0)}| = |I_{B(0)}| = (4160 \text{ V}) / -j1387\Omega = 3 \text{ A}$$

$$I_{GF} = 3I_0 = 3A \times \cos\angle 30^\circ + 3A \times \cos\angle 30^\circ = 5.2 \text{ A}$$

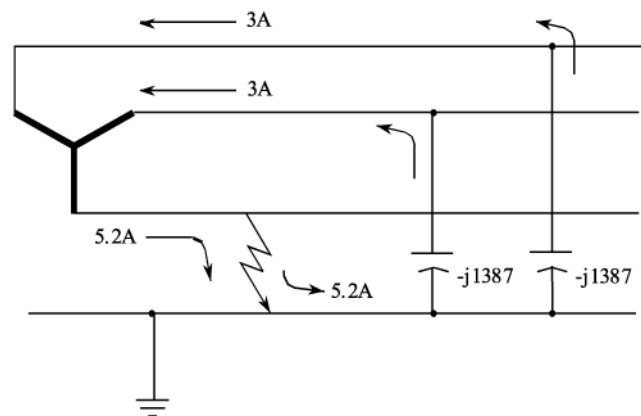

Fig. 12. Ground Faults on Ungrounded Systems

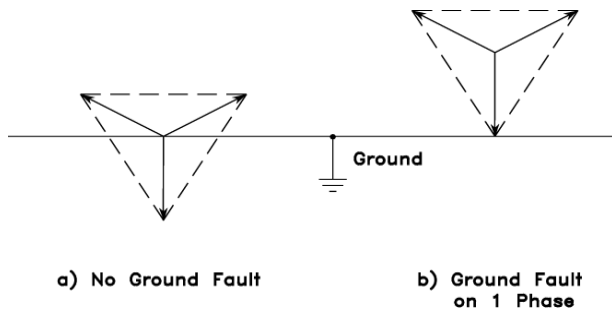

Fig. 13. Voltages During Ground Fault on Ungrounded System

Before about 1960, an ungrounded system was frequently selected for medium-voltage systems rated 5 kV or less if service continuity was of primary concern. The perception was that ungrounded systems have higher service continuity. This was based on the argument that the ground fault current is low and that negligible burning or heating will occur if the fault is not cleared. Therefore, phase-to-ground faults could be left on the system until it was convenient to find and clear them. This perception has some validity if the criterion is limited to "bolted" or "hard" faults. However, in the real world the vast majority of faults start as low level arcing ground faults. When arcing ground faults are considered, the following conditions are seldom addressed:

- 1) Multiple Ground Faults
- 2) Resonant Conditions
- 3) Transient Overvoltage

Multiple ground faults can and do occur on ungrounded systems. While a ground fault on one phase of an ungrounded system may not initiate an automatic trip, the longer the ground is allowed to remain the greater is the likelihood of a second ground occurring on another phase, because the unfaulted phases have phase-to-phase voltage impressed on their phase-to-ground insulation. In other words, the insulation is over-stressed by 73%. Also, there is an accelerated degradation of the insulation system due to the collective overvoltage impinged upon it through successive ground-faults over a period of several years. If the system insulation has not been selected for this duty, insulation degradation can accelerate even faster over time.

Although not that common, resonant conditions may result in ungrounded systems when one phase is grounded through an inductance, for example, a ground within the winding of an instrument transformer. When this happens, the high circulating currents result in high voltages across the unfaulted phases.

Transient overvoltage due to restriking or intermittent ground faults can and do develop substantial overvoltage on ungrounded electrical systems with respect to ground. The mechanism explaining how this occurs is best explained in many available publications [7, 9, 10, 11, 12, 13, 14, 15].

There have been many documented cases within industry where multiple equipment failures (e.g.-motors) over an entire 480 V system have occurred while trying to locate a ground fault. Measured line-to-ground voltages of 1,500 V or higher in these instances are not that uncommon. In all instances, the cause has been traced to a low-level intermittent arcing ground fault on an ungrounded system. Similar failures have been documented for medium-voltage (2.4 kV - 13.8 kV) systems. Fig. 14 shows the picture of a 3600 V submersible pump motor that failed due to this mechanism of voltage build-up. Two phases failed simultaneously to ground (grounded shaft).

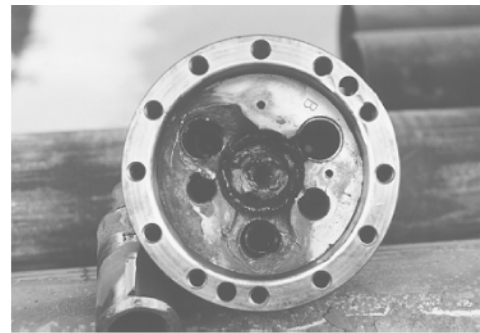

Fig. 14. Failed Motor due to Ground Fault Transient Overvoltage Build-Up

For these reasons, industry within North America is increasingly avoiding application of ungrounded systems. The ungrounded system would not be a good choice for any medium voltage system, especially those with expensive generation.

## VII. GENERATOR AND SYSTEM SOLUTIONS

The design engineer faced with the dilemma of protecting the generator for internal ground faults and providing grounding for the system has traditionally chosen one system and lived with the risks. The traditional choice for medium-voltage systems has been low-resistance grounding. This is an excellent choice for medium-voltage power systems, except for the generator itself under internal ground faults. The various solutions for grounding and protecting generators are discussed below.

### a) Generator Ungrounded and System Low-resistance Grounded

One solution to the above drawback would be to leave the generator ungrounded and low-resistance ground the external power system, as shown in Fig. 15. For ground faults external to the generator, the system would normally function as a low-resistance grounded system. However, if the ground fault occurred internal to the generator, the system would backfeed current into the ground fault and the generator protection would trip the generator breaker off-

line. Once the generator breaker is opened, the generator would be left ungrounded with an arcing ground fault present, and subjected to the transient overvoltage condition as mentioned earlier. The generator excitation system cannot reduce the field excitation fast enough to eliminate damage. Also, if the generator alone is operating without the external source, then the system will be functioning as an ungrounded system. Because of these risks, this method of system grounding is not recommended.

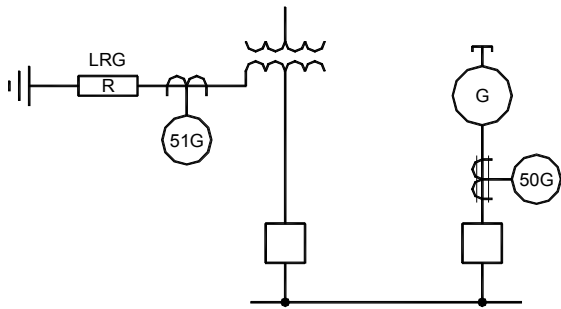

Fig. 15. Generator Ungrounded and System Low-Resistance Grounded

**b) Generator High-resistance Grounded and System Low-resistance Grounded**

Fig. 16 shows another example where the external power system is low-resistance grounded and the generator neutral is high-resistance grounded. For ground faults internal to the generator, the power system will provide current until the generator breaker opens. Once the breaker opens, the generator will remain high-resistance grounded; thereby, preventing transient overvoltages from damaging the generator. This grounding method provides the best of both worlds; the system is low-resistance grounded allowing quick tripping and isolation of any ground faults while the generator is high-resistance grounded, essentially eliminating ground fault damage and transient overvoltage damage. Where the number of cables or size of bus makes zero sequence (core-balance) CT's impracticable, 87GN protection must be substituted for the 50G function shown. See Part 3 paper for 87GN protection.

While this appears to be a good solution, it does have its limitations. The system will be high-resistance grounded when the generator is operating alone. System ground faults will not be easily detected. However, if the generator will never be operated alone without being synchronized to the external power source (which is low-resistance grounded), then this is a good choice.

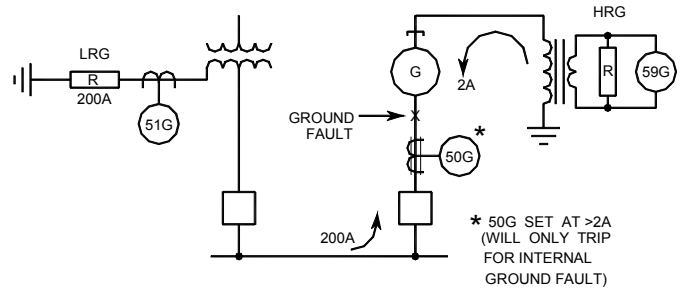

Fig. 16. Generator High-Resistance Grounded and System Low-Resistance Grounded

**c) Hybrid System**

If the power system is designed to operate either with both sources in parallel or with either source being independent, then the hybrid system shown in Fig. 17 provides a good alternative. The generator is both low-resistance grounded and high-resistance grounded. Under normal conditions, the low-resistance path prevails and controls the magnitude of fault current available from the generator. If the ground fault is in the generator zone itself, the 87GN and/or 51G protection simultaneously trips the generator breaker and the switching device in series with the low-resistance resistor. This leaves the generator high-resistance grounded during the ensuing interval as the field flux decays, thereby limiting the fault current to a level that will do significantly less damage. At the same time, the continuous presence of the high-resistance grounding equipment prevents any excessive transient overvoltage excursions during the fault clearing period.

This hybrid solution is a novel approach that has received only limited attention in the technical literature. It should be noted that the requirements imposed on the components involved in this hybrid solution are stringent, and it is very important that careful consideration be given to selecting appropriate component ratings for the application.

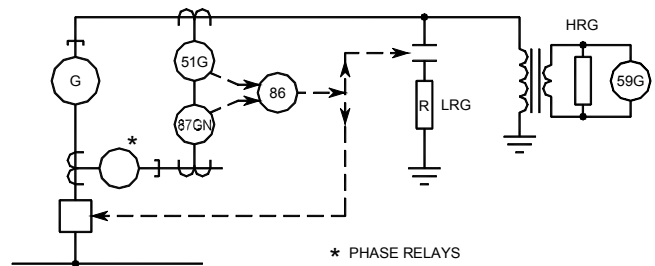

Fig. 17. Hybrid System

**d) Generator and External Source High-resistance Grounded, and Bus Low-resistance Grounded**

A variation of the above options is shown in Fig. 18 where the external source and the generator are high-resistance grounded with the bus being low-resistance grounded via a grounding transformer. This approach can be made to work equally well provided it can be assured that the bus ground will be present at all times.

This grounding method would allow the system to continue to operate with the uncleared high-resistance ground fault present if the condition is alarmed and the personnel are available to respond and locate the fault for clearing it in a timely manner (bus ground off-line or for an extremely low level ground fault). Otherwise, it would need to operate as a conventional low-resistance grounded system. This operational consideration would only be practicable for very small systems less than 7.2 kV.

For larger or higher voltage systems that cannot be adequately high-resistance grounded, the 51G relay must trip the generator and source transformer breakers rather than the grounding transformer breaker when there is an uncleared ground fault downstream. Careful consideration must be given to all potential normal and abnormal operating scenarios, including those configurations that may be called upon under unplanned contingencies to permit plant operation to continue in the event of some unexpected component failure.

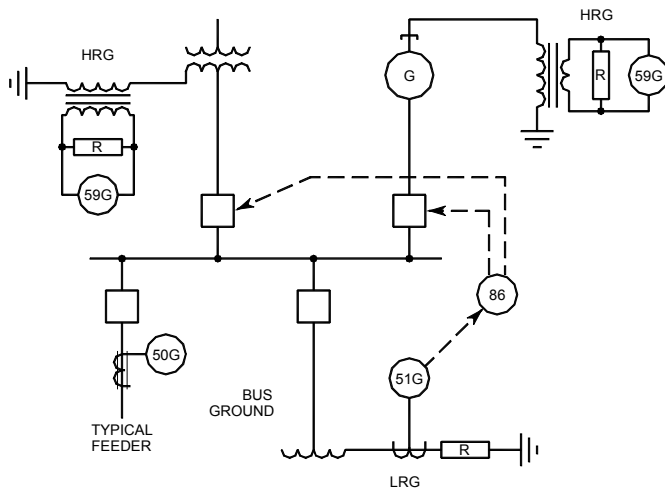

Fig. 18. A Variation of Hybrid System

**e) All Sources High-resistance Grounded**

Another approach would be to employ high-resistance grounding of all sources on the system, thereby limiting the total system ground fault current to a few tens of amperes. A more difficult challenge at higher voltages (above 7.2 kV) is the need to quickly detect and clear faults before a single-

line-to-ground fault can escalate and involve other phases. In all instances, selective fault clearing is more difficult when the available fault current is severely limited. There are technologies available that will address this problem at the expense of greater complexity in the protection system.

For those systems with existing delta connected generators and transformers, the grounding solutions as illustrated in figures 16, 17 and 18 can be realized using grounding transformers to derive the neutral grounding point. Three single-phase transformers or a zig-zag grounding transformer can be employed to create either high-resistance grounding or low-resistance grounding, depending on the system design [12, 16].

**VIII. SUMMARY**

This paper presented Part 2 of a four-part Working Group Report on generator grounding and ground fault protection. Part 2 discussed the various grounding methods used in industrial installations, reviewing their advantages and limitations. The intent of this paper was to present alternative ways of minimizing medium-voltage generator damage from internal ground faults as identified in Part 1. The schemes as presented in figures 16, 17 and 18, are meant to provide the primary concepts of maintaining a low-resistance grounded power system and the benefits of a high-resistance grounded generator, under several possible scenarios. Using some form of these hybrid system grounding techniques will allow power system engineers to both protect the generator and provide reliable power system protection using proven low-resistance grounding designs. It is this committee's recommendation that some form of these choices be selected but with the understanding that no part of the system should be ever left completely ungrounded, especially the costly generator itself.

Part 1 of this Working Group Report provided an introduction and discussion of the generator damage mechanism during stator ground faults. Part 3 describes the protection methods for the various types of grounding and Part 4 includes a conclusion and bibliography of additional reference material on the subject of generator grounding and ground fault protection.

**IX. REFERENCES**

- [1] *NEMA Standard for Motors and Generators*, NEMA Standard MG1-1998 (Rev. 1, 2000).
- [2] *IEEE Standard Requirements, Terminology and Test Procedures for Neutral Grounding Devices*, IEEE Standard 32, 1972 (Reaff 1997).
- [3] L. J. Powell, "Influence of third harmonic circulating currents in selecting neutral grounding devices," *IEEE Transactions on Industry Applications*, vol. IA-9, Nov./Dec. 1973, pp. 672-679.
- [4] E. M. Gulachenski and E. W. Courville, "New England Electric's 39 years of experience with resonant neutral

- grounding of unit-connected generators," *IEEE Transactions on Power Delivery*, vol. 6, Jul. 1991, pp. 1016-1024.
- [5] K. J. S. Khunkhun, J. L. Koepfinger, and M. V. Haddad, "Resonant grounding (ground fault neutralizer) of a unit connected generator," *IEEE Transactions on Power Apparatus Systems*, vol. PAS-96, 1977, pp. 550-559.
- [6] H. R. Tomlinson, "Ground-fault neutralizer grounding of unit connected generators," *AIEE Transactions on Power Apparatus Systems*, vol. 72, Part III, Oct. 1953, pp. 953-966.
- [7] *Industrial Power Systems Data Book*. Schenectady, NY: General Electric Company, 1956.
- [8] *IEEE Guide for Generator Ground Protection*, IEEE Standard C37.101, 1993.
- [9] *Industrial Power System Hand Book*. D. Beeman, Editor, New York: McGraw-Hill, 1955.
- [10] *Electric Transmission and Distribution Reference Book*, 4<sup>th</sup> edition, East Pittsburgh, PA: Westinghouse Electric Corporation, 1964.
- [11] Harold A. Peterson, *Transients in Power Systems*. New York: Dover Publications, Inc., 1966.
- [12] D. Shipp and F. Angelini, "Characteristics of different power systems neutral grounding techniques: fact & fiction," in *Conference Record of IEEE IAS Annual Meeting*, 1988.
- [13] J. R. Dunki-Jacobs, "The escalating arcing ground fault phenomenon," *IEEE Transactions on Industry Applications*, Nov./Dec., 1986.
- [14] C. L. Wagner, "Effect of grounding impedance on the magnitude of transient overvoltage due to arcing grounds," *Westinghouse Transmission and Distributions Systems*, 1960.
- [15] E. Clarke, S. B. Crary, and H. A. Peterson, "Overvoltages during power-system faults," *AIEE Transactions on Power Apparatus Systems*, vol. 58, August 1939, pp. 377-385.
- [16] *IEEE Recommended Practice for Grounding of Industrial and Commercial Power Systems (The Green Book)*, IEEE Standard 142, 1992.