

**NBR/NSR SERIES, MODEL M83  
ENCLOSED CIRCUIT BREAKERS/ SAFETY  
SWITCHES WITH INTERLOCKED  
ARKTITE® RECEPTACLES**

**Installation and Maintenance  
Information — IF980 8/83**

**APPLICATION**

NSR Series enclosed safety switches with interlocked ARKTITE receptacles are designed to provide connection and distribution of secondary electrical power (600 volts or less) between a power source and portable or stationary electrical equipment. Fusible type NSR safety switches also provide short circuit protection.

NSR Series enclosures are supplied in both 3-wire, 3-pole fusible and non-fusible arrangements with Style 1 grounding where ground is connected through the shell; and 3-wire, 4-pole fusible and non-fusible arrangements with Style 2 grounding where ground is connected through an extra pole and the shell. Both Style 1 and Style 2 arrangements are supplied in 30, 60, or 100 ampere ratings at 600VAC/250VDC or 240VAC/250VDC.

NBR Series enclosed circuit breakers with interlocked ARKTITE receptacles are designed to supply secondary electrical power (600VAC or less) and provide short circuit protection, thermal overload protection, and a disconnect means to portable or stationary electrical equipment.

NBR Series enclosures are supplied in both 3-wire, 3-pole arrangements with Style 1 grounding where ground is connected through the shell; and 3-wire, 4-pole arrangements with Style 2 grounding where ground is connected through an extra pole and the shell. Both Style 1 and Style 2 arrangements are supplied in 30, 60 and 100 ampere receptacle ratings. NBR

Series enclosures provide a 100 ampere frame size with non-interchangeable trip breakers rated 20 through 100 amperes available.

NBR and NSR Series enclosures are interlocked both with the enclosure door and ARKTITE receptacle. The plug cannot be withdrawn or inserted unless the switch/breaker is open (OFF). The enclosure door cannot be opened when plug is engaged and the switch/breaker is closed (ON). When the switch/breaker is open (OFF) the switch/breaker cannot be put in a closed (ON) position with the door open.

The ARKTITE receptacles supplied with the NBR and NSR Series enclosures are polarized to prevent mis-matching. Each enclosure is used with specific Crouse-Hinds APJ, NPJ, CPH and CPP Series ARKTITE plugs with the same electrical ratings, grounding style and contact configurations. Refer to Crouse-Hinds 4000 series catalogs for a complete listing of compatible NBR and NSR Series Interlocked ARKTITE receptacles and matching ARKTITE Plugs.

NBR and NSR Series products are designed for use in non-hazardous industrial areas that are subjected to corrosion, dust, dirt, chemical vapors or moisture, both indoors and outdoors.

The NBR and NSR Series enclosures must be installed, inspected, operated and maintained by qualified and competent personnel.

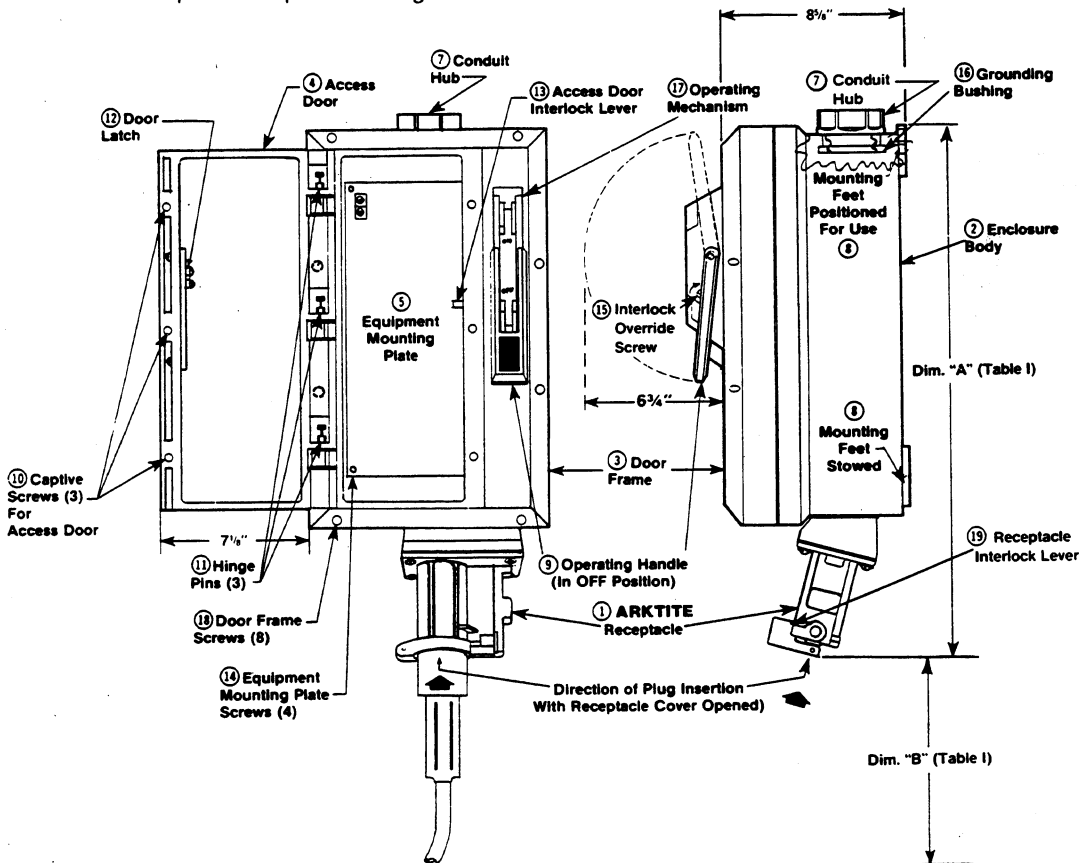

## GENERAL DESCRIPTION

NBR and NSR interlocked receptacles are provided with either a circuit breaker or safety disconnect switch installed in an enclosure made of KRYDON® material. These enclosures consist of a body ② and a two-piece cover assembly made up of a frame ⑬ mounted with a circuit breaker or safety switch operating mechanism ⑰ and a hinged access door ④.

Adjustable mounting feet ⑧ and a conduit hub ⑦ both made of KRYDON material, are provided with each enclosure.

The ARKTITE® interlocked receptacle ① is attached externally to the bottom of the enclosure so that a matching ARKTITE plug is inserted in an upward direction.

NBR/NSR Dimensions (in.)		
Amp Rating	Dim. A	Dim. B*
30	31-7/8	10
60	33-3/8	12
100	34-1/8	14

\*Dim. B is the minimum clearance required below receptacle for plug insertion and removal.

Table I. (See Figure 1.)

## ENCLOSURE DISASSEMBLY

### WARNING

Electrical power must be turned OFF before and during installation and maintenance.

1. Place operating handle in OFF (downward) position so black indicator is visible.
2. Loosen three captive screws in access door and open door.  
Note: If door will not open and is being held by the internal door latch, locate the interlock override screw on the right side of the operator housing. Lift operating handle slightly to expose the screw, then rotate screw clockwise with screwdriver while simultaneously lifting the access door to open.
3. Slide hinge pins into upper portion of hinge retainers, then remove door and carefully set it aside.

## CONDUIT HUB INSTALLATION

NBR and NSR Enclosures are furnished without conduit opening. Refer to the installation instructions furnished with conduit hub for proper installation procedure.

All machining should be done prior to installation of enclosure.

The preferred conduit entrance location is at the top of the enclosure where more adequate field wiring space is available.

Note: Crouse-Hinds NHUB Series conduit hubs are recommended for use with NBR and NSR enclosures.

1. Locate and drill conduit hub opening, then install conduit hub. While making hole in enclosure body, protect circuit breaker/safety switch with a clean cloth so particles will not enter the device. Clean all foreign material out of enclosure after hub installation.

### 2. Grounding and Bonding:

The bonding and grounding of the conduit and equipment is required by the National Electrical Code. All internal mounting plates must be bonded to the conduit. See Table II. Ground continuity between conduit and mounting plate must be maintained through proper bonding. A grounding conductor, if used, must be connected to the conduit bonding system.

Use Crouse-Hinds Type GB grounding bushing provided.



Conduit Size	Grounding Bushing Cat. #	Conduit Hub Cat. #
3/4"	GB1042	NHUB2
1-1/4"	GB1044	NHUB4
2"	GB1046	NHUB6

Figure 2.  
Grounding Bushing/Conduit Hub.

Minimum Size Grounding Conductor (copper wire)	Rating or Setting Device in Circuit Ahead of Equipment
#10 AWG	30 Amps
#10 AWG	60 Amps
# 8 AWG	100 Amps

Table II.  
1982 NEC Table 250-95

### WARNING

NBR/NSR receptacle housings must be securely attached into a permanently grounded system in accordance with Article 250 of the National Electrical Code.

Determine the type of distribution system to be used that will comply with NEC requirements and ensure grounding continuity.

Proper grounding of systems and circuit conductors is required to limit hazardous voltages caused by lightning, line surges or unintentional contact with higher voltage lines and to stabilize the voltage to ground during normal operation. All conductive materials that enclose the electrical conductors or attached equipment or forming part of such equipment must be grounded. A permanent conducting connection must be made between all such equipment and the earth.

Typical distribution systems are illustrated below:

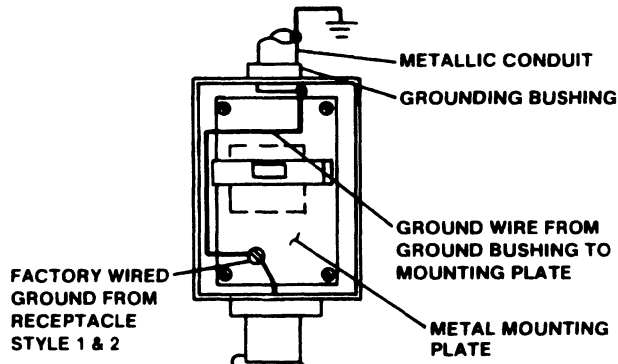

**METALLIC CONDUIT SYSTEM**

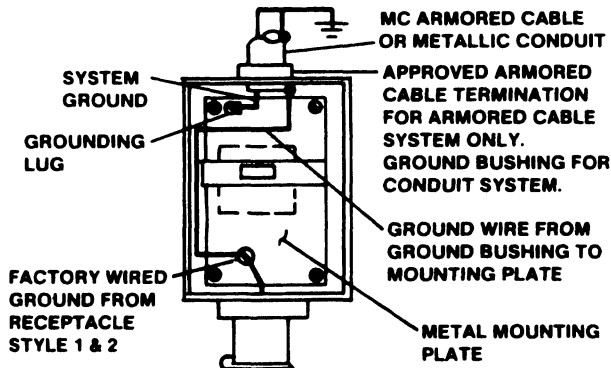

**MC METALLIC ARMORED CABLE OR METALLIC CONDUIT WITH SEPARATE GROUNDING CONDUCTOR**

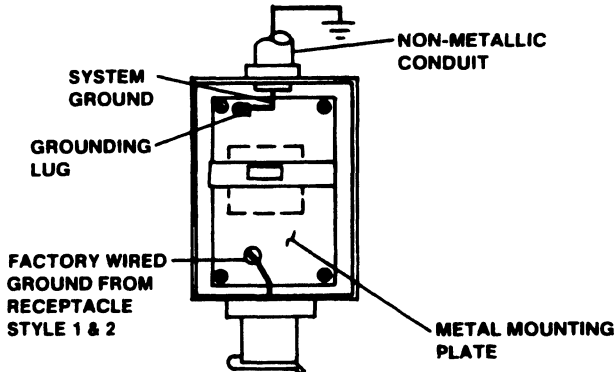

**NON-METALLIC CONDUIT SYSTEM**

**Figure 3.  
Grounding Systems**

**ENCLOSURE INSTALLATION**

1. Select mounting location that will provide suitable strength and rigidity for supporting the enclosure and all contained wiring. The mounting dimensions for the four mounting feet for lag screws or mounting bolts are shown in Figure 4.

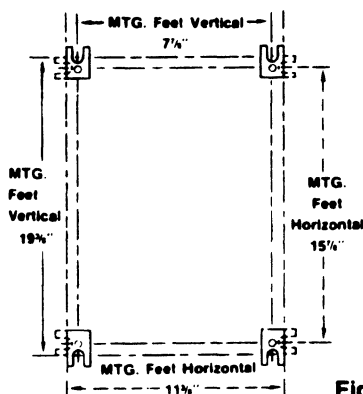

**Figure 4.**

- Enclosure is shipped with feet stowed inwardly. Screws holding feet must be loosened and the feet then turned outward to desired vertical or horizontal position. Make sure feet are seated firmly in recess before tightening down holding screws.

Note: Do not exceed 30-35 in. lbs. torque.

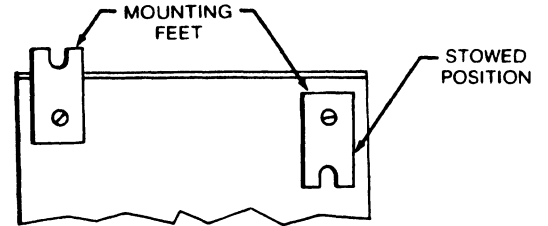

**Figure 5.  
Mounting Feet**

- Slots in mounting feet allow the use of mounting bolts up to 1/2 inch diameter, however, 3/8 inch diameter mounting bolts are recommended.
- A flat washer must be installed under the heads of all four mounting fasteners.

**CAUTION**

Use only corrosion resistant mounting hardware.

- Always locate enclosure in vertical position with receptacle contacts pointing downward.
  - The recommended mounting height from ground to floor level to the bottom of the receptacle is 42 to 52 inches.
2. Securely fasten enclosure in desired location.
  3. Install conduit in entrance hubs following instructions supplied with each hub.

**WIRING CONNECTIONS**

1. Establish a wiring pattern for your system.

**WARNING**

Before installing a NBR/NSR Series enclosed safety switch/circuit breaker and interlocked ARKTITE receptacle, a wiring pattern must be established for your system. Locations having different voltages, frequencies or types of current (AC or DC) **MUST NOT** have interchangeable attachment plugs as stated in paragraph 210-7F of the National Electrical Code.

2. Connect grounding conductor. Pull all phase conductors into enclosure and make connections to the line side pressure connector terminations following the wiring pattern established for your system.

3. Check plug/receptacle polarization.

The ARKTITE receptacles on the NBR/NSR enclosure are polarized so that mating plugs can enter the receptacle only one way. Also, the mating contacts in the receptacle and corresponding plug are identified by numbers on the insulating recesses. **Note:** Some ARKTITE plugs manufactured prior to 1982 identify the mating contacts by color. Contact members in the receptacle must always mate with those in a plug identified by the same number (or color). This assures proper polarity or phase rotation of conductors through receptacle and plug.

Usually the conductors in a cable or conduit system are identified by the color of the insulation covering each individual conductor. We assume that these colors agree with those given in Section 210-5 of the National Electrical Code for multi-wire branch circuits; also, that there is an additional wire in the cable or conduit system that is uninsulated or identified green that is for equipment grounding and complies with Sections 250-42 and 250-45 of the National Electrical Code. If the conductors are not identified with exactly these colors, these colors may be assumed when making proper connections.

For each system the same colored wire must be attached to the same numbered (or color coded) contact on all plugs and receptacles in that system. This will assure correct system polarity and reduce the possibility of equipment damage and/or personal injury due to misphasing or electrical shorts.

If all conductor colors are alike except one, that one may be assumed to be white and all the others will probably be in the same relative location from the white wire at the other end of the same cable. **However**, lacking positive color identification of each conductor, **ALWAYS** test them out electrically.

Assuming conductor color identification as described earlier, connect conductors identified by color in the proper column in Table III through corresponding contacts in the plug and receptacle identified by number (or color) listed. The white wire should always be connected through the #2 contact (or white color code).

NBR/NSR Style	Color of Conductors	Plug and Receptacle Contact Identification	
		Number	Color***
3-Wire 3-Pole Style I	White*	Contact #2	White
	Black	Unidentified	Unidentified
	Red	Contact #1	Red
3-Wire, 4-Pole Style II	Green**	Grounding Lug Only	Grounding Lug Only
	White*	Contact #2	White
3-Wire, 4-Pole Style II	Black	Contact #3	Orange
	Red	Contact #1	Red
	Green**	GR (Grounding Contact)	Unidentified

\*White wire or terminal must not be used for grounding. If one conductor is uninsulated, or identified green, this wire is for grounding the portable device. If no green or bare wire is available, another wire may be connected through plug and receptacle connections to conduit or some other non-current-carrying conductor permanently grounded in accordance with Article 250 of the 1981 National Electrical Code.

\*\*Use pressure type termination

\*\*\*ARKTITE\* plugs manufactured prior to 1982.

Table III

STYLE I GROUNDED THROUGH RECEPTACLE SHELL

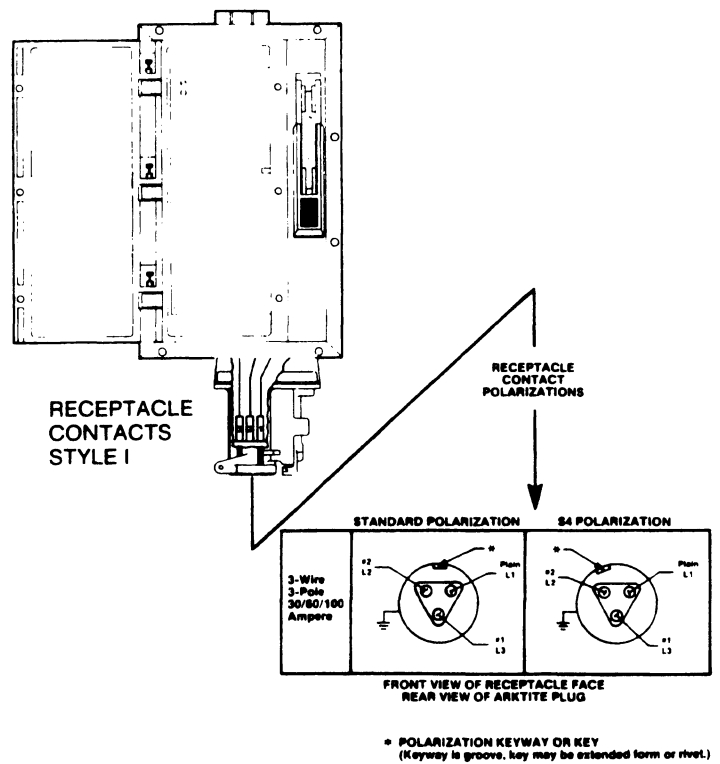

STYLE II GROUNDED THROUGH EXTRA GROUND CONTACT

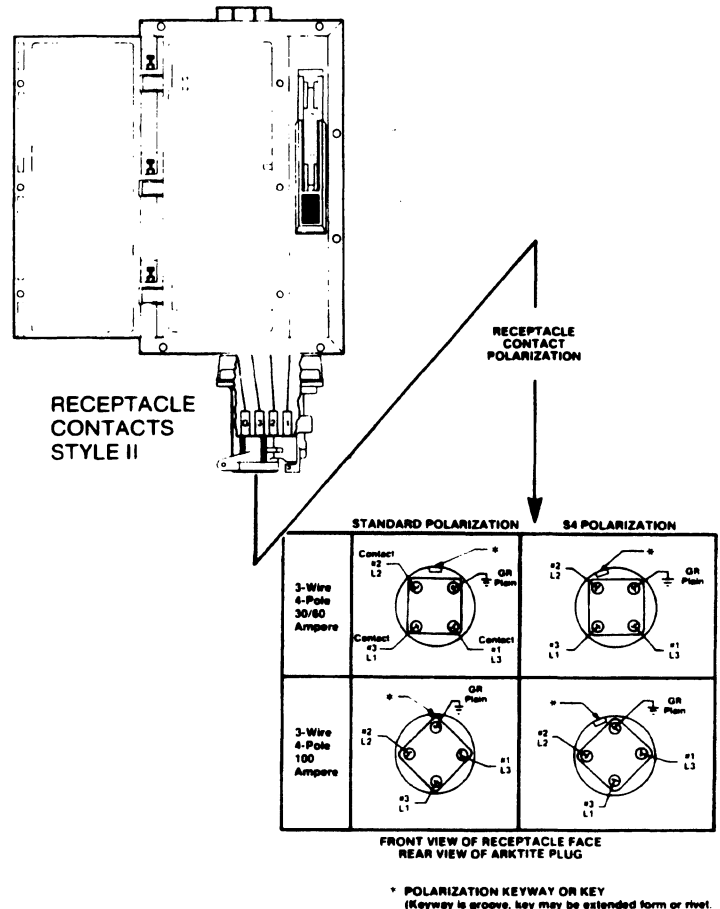

Figure 6. Contact Polarization

4. Install proper rated cartridge fuses (not included with unit) where used. Refer to warning label located in enclosure for fuse type and National Electrical Code® class arrangement.
5. Test wiring for correctness with continuity check and also for unwanted grounds with an insulation resistance check.
6. Place operating handle in open (OFF) position. Reinstall door on hinges, sliding hinge pins into lower portion of hinge. Close door, but do not tighten captive screws yet.

**CAUTION**

Clean all dirt or foreign material from mating surfaces of access door and enclosure body before closing.

**OPERATIONAL TESTING**

1. Before turning on power to NBR/NSR enclosure, check safety interlock mechanism for proper operation.

**CAUTION**

Forcing the operating handle mechanism without using proper ARKTITE plug or with enclosure door open will damage safety interlocks.

NBR/NSR receptacle assembly is designed with an access door interlock and receptacle interlock to prevent a plug from being mated or withdrawn while energized. The access door interlock prevents operator handle actuation when the access door is open and potentially live electrical components are exposed. It is automatically released by a closed door or may be manually released (overridden) with access door open by depressing the access door interlock lever towards the receptacle.

The receptacle interlock prevents insertion of an ARKTITE plug unless the switch/circuit breaker is deenergized. After the plug is inserted, the unit may be turned ON. With the unit ON, the inserted plug is locked into the receptacle and cannot be withdrawn.

2. With operating handle in the OFF position, close access door and insert proper ARKTITE plug fully into receptacle. Interlock lever will automatically rotate forward.
3. After inserting plug, place operating handle in ON position using reasonable force on the handle. Check safety interlock mechanism for proper operation:
  - Plug cannot be withdrawn
  - Access door cannot be opened (make sure that screws are loose)

If plug can be withdrawn, discontinue use immediately and return enclosure to factory.

If access door opens, refer to Adjustments section of instructions.

4. Place operating handle in OFF position and check to see if access door can be opened. If door cannot be opened, refer to Adjustments section of instructions.
5. Close access door and retighten the three captive screws. Turn on power to unit.

**ADJUSTMENTS**

**Access Door Interlock Latch:**

If unit cannot be turned "ON" with access door closed, open door and loosen two door latch adjusting screws. Move latch up approximately 1/16" then retighten screws (to 20-25 lb. in. torque) and close door. Repeat this procedure until unit can be turned ON.

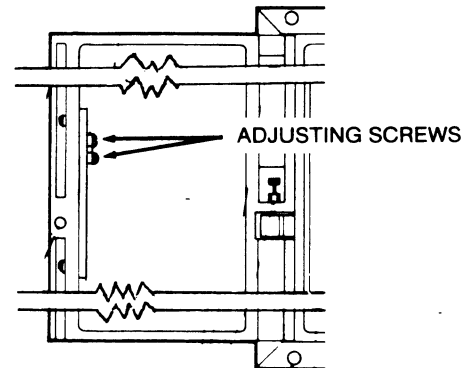

**Figure 7.  
Door Latch Adjusting Screws**

If access door can be opened while unit is turned ON, open door and loosen two door latch adjusting screws. Move latch down approximately 1/16" then retighten screws (to 20-25 lb. in. torque) and close door. Repeat this procedure until door latches and unit can be turned ON.

**Tripped Circuit Breaker (NBR Enclosures):**

The operating handle will remain in the "ON" position when the breaker "trips". After correcting the cause for the tripped breaker, reset by briskly turning the operating handle to the "OFF/RESET" position and then returning it back to the "ON" position.

## MAINTENANCE

### WARNING

Always disconnect primary power source before opening enclosure for inspection or service.

1. Frequent inspection should be made. A schedule for maintenance check should be determined by the environment and frequency of use. It is recommended that it should be at least once a year. We recommend an Electrical Preventive Maintenance program as described in the National Fire Protection Association Bulletin NFPA No. 70B.
2. Perform visual, electrical, and mechanical checks on all components on a regular basis.
  - Visually check for undue heating evidenced by discoloration of wires or other components, damaged or worn parts, or leakage evidenced by water corrosion in the interior.
  - Electrically check to make sure that all connections are clean and tight, and that contacts make or break as required.
  - Mechanically check that all parts are properly assembled, interlocks working, and operating mechanisms move freely.

### WARNING

If any part of the switch, receptacle and/or plug appears to be broken or damaged,

#### **DISCONTINUE USE IMMEDIATELY.**

Replace, or properly repair the item before continuing service.

3. Test wiring for correctness with continuity checks and for unwanted grounds with insulation resistance tester.
4. Place operating handle in open (OFF) position then close cover and secure with three captive screws.
5. Before turning on power to NBR/NSR enclosure, check safety interlock mechanism for proper operation.
  - The plug cannot be inserted or withdrawn unless the switch is open (OFF).
  - The enclosure door cannot be opened when the plug is inserted and the switch closed (ON). When the switch is open (OFF), it cannot be put in a closed (ON) position with the door open.

### CAUTION

Forcing the operating handle mechanism without using proper ARKTITE plug or with enclosure door open will damage safety interlocks.

---

*All statements, technical information and recommendations contained herein are based on information and tests we believe to be reliable. The accuracy or completeness thereof are not guaranteed. In accordance with Crouse-Hinds "Terms and Conditions of Sale", and since conditions of use are outside our control, the purchaser should determine the suitability of the product for his intended use and assumes all risk and liability whatsoever in connection herewith.*

---

 **COOPER** Crouse-Hinds

CONSTRUCTION MATERIALS PRODUCTS DIVISION • P.O. Box 4999, Wolf & Seventh North St. • Syracuse, New York 13221

©1983, Cooper Industries, Inc.

IF980 8/83  
New Issue