



**Arktite® Heavy Duty Plug  
Made of Krydon® Material  
NPJ Series, Model M1  
Style 2; 30, 60 & 100 Ampere**

**SAVE THESE INSTRUCTIONS  
FOR FUTURE REFERENCE**

**IF865**

**Installation &  
Maintenance Information**

**APPLICATION**



NPJ Series ARKTITE® heavy duty plugs are designed to provide connection and distribution of secondary electrical power (600 volts or less) between power source and portable or stationary electrical equipment. NPJ Series plugs are supplied in 3 and 4 pole designs. They are capable of carrying a maximum continuous current of 30, 60 or 100 amperes at a rated voltage of 600 volts AC from 50 through 400 Hertz, or 250 volts DC. NPJ Series plugs are style 2, in which the extra (grounding) pole connection is made before line and load poles engage and is broken after line and load poles disengage.

NPJ Series plugs are designed for use in hazardous and non-hazardous areas — indoors or outdoors. When properly maintained and installed, NPJ plugs are designed to provide safe and reliable operation in wet, damp, dirty and corrosive industrial environments.

Third Party Approval — NPJ 30, 60 and 100 ampere plugs with pressure termination type contacts are UL listed for use in Class I, Division 1, Groups C, D and Class II, Division 1, Groups F, G hazardous (classified) areas as defined by the National Electrical Code®.

**NOTE:** Crouse-Hinds Krydon Arktite plugs are intended for use with the following flexible cord or cable, per the National Electrical Code®, Article 400:

- Portable Power Cable
- Thermoset Jacketed Heater Cord
- Hard Service Cord
- Flexible Stage & Lighting Power Cable
- Junior Hard Service Cord

These plugs may also be used with the following cord and cable identified in the Canadian Electrical Code, Section 4-010:

- Flexible Cord (for hard or extra hard usage)
- Outdoor Flexible Cord
- Portable Power Cord

**INSTALLATION**

**CAUTION**

To reduce the risk of ignition of hazardous atmospheres, do not use NPJ Series plugs in Class II, Group F locations that contain electrically conductive dusts.

NPJ Series plugs are used with Crouse-Hinds NR Series receptacles and the NPR Series cord connectors. NPJ plugs can also be

used in AAP, AEQ, AR, APR, DBR, DR, EPC, EPCB, FAR, FSQ, NBR, NSR, WSRD AND WSR receptacles.

Refer to Crouse-Hinds Product catalogs for a complete listing of compatible ARKTITE heavy duty receptacle housings and connectors.

For proper operation of NPJ plugs in DR receptacles remove both clamping nut and plug flange gasket from NPJ assembly.

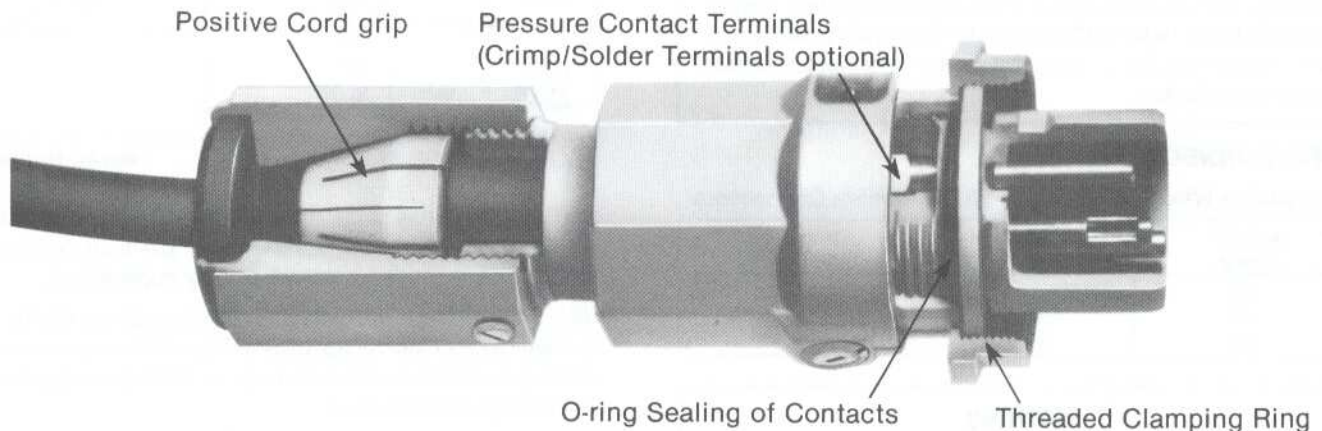

**Figure 1. Cutaway View - NPJ Plug (4 pole style shown)**

©National Electrical Code is a Registered Trademark of the National Fire Protection Association.  
©ARKTITE and KRYDON are Registered Trademarks of Crouse-Hinds ECM.

## PLUG DISASSEMBLY

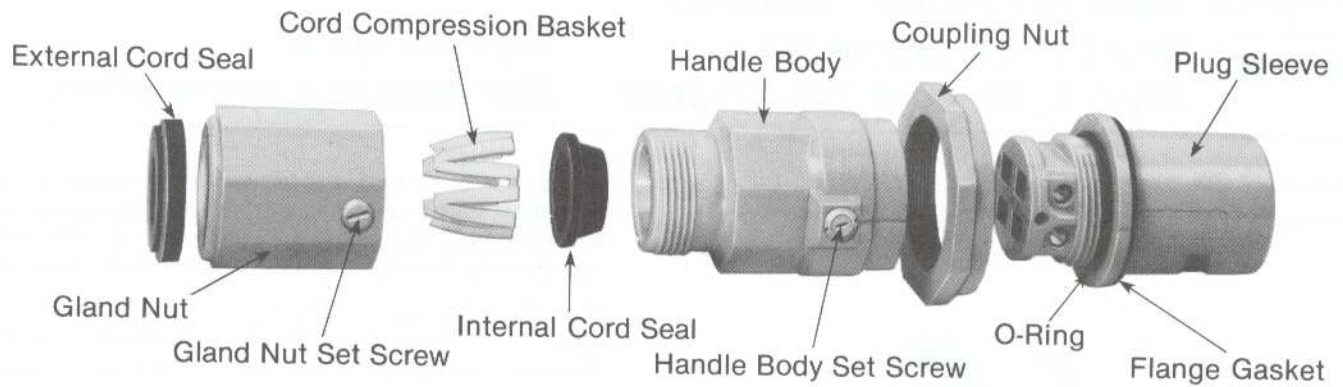

Figure 2. NPJ Series ARKTITE Plug

### CAUTION

NPJ plugs may be mated with ARKTITE receptacles in both hazardous and ordinary locations. However, the equipment and the attached NPJ plug **MUST** be approved for use in the intended location. ARKTITE receptacles will accept NPJ plugs which may be used with equipment not suitable for hazardous locations. If ordinary location equipment to which NPJ's are attached must be used in a normally hazardous area, that area **MUST** be purged of the hazard and declared non-hazardous.

NPJ Series plugs should be installed, inspected, maintained, and operated only by qualified and competent personnel.

1. Loosen gland nut set screw and unscrew gland nut from handle body.
2. Remove the cord compression basket and internal elastomeric cord seal.
3. Loosen the handle body set screw approximately 1/4 inch, then unscrew handle body from plug sleeve. Remove clamping nut.
4. **Do not remove** pressure termination type contacts from plug sleeve.

### CAUTION

NPJ Series plugs, identified by the addition of suffix T to the catalog number, are supplied with crimp or solder termination type contacts. Refer to Crimp/Solder Termination section of the instructions for proper installation information before proceeding further.

## CORD CONNECTION

### Acceptable Wire Sizes For Use With Pressure Connectors

Ampere Rating	Diameter of Recess	Wire Sizes Extra Flex
30	0.281	#10 - #8
60	0.312	#8 - #4
100	0.390	#4 - #2

### WARNING

Electrical power must be turned **OFF** before and during installation and maintenance.

1. Establish a wiring pattern.

### WARNING

Before assembling an NPJ Series plug, a wiring pattern must be established for your system. Locations having different voltages, frequencies or types of current (AC or DC) **MUST NOT** have interchangeable attachment plugs per section 210-7F of National Electrical Code and/or per rule 26-700(4) of Canadian Electrical Code.\* For each system the same colored wire must be put into the same numbered contact on all plugs and receptacles in that system. This will assure correct system polarity and eliminate the possibility of equipment damage and/or personal injury due to misphasing or shorts.

ARKTITE plugs and receptacles are polarized so plug enters receptacle only one way. Contact recesses in insulating bodies are identified by number. This provides for proper polarity of conductors through plug and receptacle or cord connector.

Figure 3. Standard Polarization

Figure 4. S4 Polarization

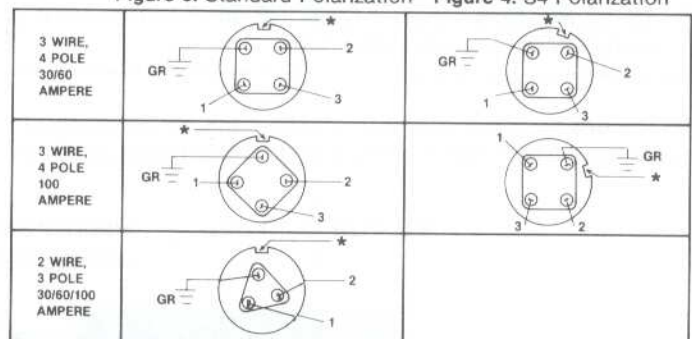

FRONT VIEW OF ARKTITE PLUGS

\*POLARIZATION KEYWAY

**NOTE:** NPJ Series plugs, identified by the addition of suffix S4 to the catalog number, are supplied with the plug contact pattern rotated 22½ degrees for special polarity applications.

NPJ Series plugs with rotated contact patterns (Suffix S4) are compatible only with receptacles and cord connectors built with the same special feature. Always compare catalog numbers located on unit nameplates if in doubt.

To ensure uniformity of the system, follow these instructions or use your own established standards. Electrical continuity testing is required to verify proper polarization.

\*Canadian Electrical Code — A voluntary code for Adoption and Enforcement by Regulatory Authorities.



- Select the internal and external elastomeric seal and cord compression basket that are compatible with the diameter of the cord to be attached to the NPJ Series plug. The cord diameter range of each elastomeric seal and cord compression basket is marked on them. Refer to Table 1 following for the NPJ Series plug catalog number and the corresponding cord diameter, internal and external seal part numbers, and cord compression basket part number.

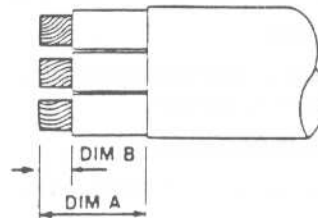

NPJ Plug	Dimensions (in.)	
	A	B
30 amp	2-15/16	1/2
60 amp	2-5/8	3/4
100 amp	3-1/4	7/8

Figure 6. Cord Insulation

UL1010 strain relief values of 150 pounds (30 ampere NPJ plug) or 300 pounds (60 and 100 ampere NPJ plug) are produced when: (1) the gland nut is torqued to the values indicated in Step 3 of Plug Assembly section following; (2) the cord diameter is within the range indicated in Table 1 and; (3) the minimum cord conductor size is as follows: #10 AWG or 30 ampere plugs, #6 AWG for 60 ampere plugs and #2 AWG for 100 ampere plugs.

TABLE 1

NPJ Plug Ampere Rating	NPJ Plug Catalog Number	Cord Grip Range Diameter (In.)	Internal Cord Seal Part Number	External Cord Seal Part Number	Cord Compression Basket Part Number
30	NPJ3383	.55- .70	0401817	0401828-1	0401808
	NPJ3384	.70- .85	0401818	0401828-2	0401809
	NPJ3483	.55- .70	0401817	0401828-1	0401808
	NPJ3484	.70- .85	0401816	0401828-2	0401809
60	NPJ6384	.75- .93	0402114	0401828-3	0401810
		.93- 1.07	0402115	0401828-4	0401811
	NPJ6385	1.07-1.21	0402116	0401828-4	0401812
		1.21-1.35	0402117	0401828-5	0402108
	NPJ6484	.75- .93	0402114	0401828-3	0401810
		.93-1.07	0402115	0401828-4	0401811
NPJ6485	1.07-1.21	0402116	0401828-4	0401812	
	1.21-1.35	0402117	0401828-5	0402108	
100	NPJ10386	* .93-1.07	0402124	0401828-6	0401811
		* 1.07-1.21	0402125	0401828-7	0401812
	NPJ10387	* 1.21-1.35	0402126	0401828-7	0402119
		* 1.35-1.50	0402127	0401828-8	0402119
	NPJ10486	* .93-1.07	0402124	0401828-6	0401811
		* 1.07-1.21	0402125	0401828-7	0401812
	NPJ10487	* 1.21-1.35	0402126	0401828-7	0402119
		* 1.35-1.50	0402127	0401828-8	0402119

\* Cord grip range of .93-1.35 requires use of 0402123 gland nut insert which is snapped into gland nut. Remove gland nut insert to accommodate 1.35-1.50 cord grip range.

- Connect wires, identified by color in center column of Table 2, to contacts identified by number noted in column to the right. White wire is connected to contact identified by #2. Connect other contacts in accordance with color of wires.

Conductors are identified by the color of insulation on each individual conductor. These colors agree with those given in Section 210-5 of National Electrical Code and/or Rule 4-036 of Canadian Electrical Code for multi-wire branch circuits; an additional wire in the cord, uninsulated or identified green, is for grounding and complies with Sections 250-42 and 250-45 of National Electrical Code, and/or Rules 10-400 and 10-408 of Canadian Electrical Code. If conductors are not identified with exactly these colors, these colors may be assumed in making proper connections.

If the conductors are all alike except one, that one is to be assumed to be white and the others to be in the same relative locations at the other end of same cord. Lacking positive color identifications, test by checking electrical continuity.

TABLE 2

Plug Style	Color of Wire In Cord	Numbers On Plug Sleeve
3 Pole	White*	Contact #2
	Black	Contact #1
	Green* *	GR (Grounding Contact)
4 Pole	White*	Contact #2
	Black	Contact #3
	Red	Contact #1
	Green* *	GR (Grounding Contact)

**NOTE:** All installations must be electrically tested to assure proper polarity of conductors between plugs, receptacles and connectors.

\* White wire or terminal must not be used for grounding. The portable cord must contain an uninsulated wire, or one identified green, this wire is for grounding the portable device in accordance with Article 250 of the 1981 National Electrical Code, and Section 8 of Canadian Electrical Code.

\*\*Use pressure type termination.

- Loosen (but do not remove) pressure connector screws on contacts then insert conductors into wire wells according to your established wiring pattern. Conductors must bottom in contact wire well and insulation must extend below surface of plug sleeve. Tighten contact pressure connector screws securely to the torque values listed in Table 3.

TABLE 3

Assembly Amperage	Minimum Required Contact Screw Torque (In.-Lbs)
30	30
60	40
100	50

**CAUTION**

Do not cut into the individual conductor insulation when removing the outer cord jacket. Do not damage the conductor when removing its insulation.

- Slide external cord seal, gland nut (elastomeric seal end first), cord compression basket (tapered end first, internal elastomeric seal, handle body and clamping nut over cord. See Figure 5.



Figure 5. Gland Nut, Cord Compression Basket Detail

- Strip outer cord jacket and then conductor insulation to the dimensions shown in Figure 6. A conductor strip gage is also located on the plug sleeve. These dimensions will permit the conductor to bottom in the contact wire well and the conductor insulation to extend into the insulated plug sleeve recesses.



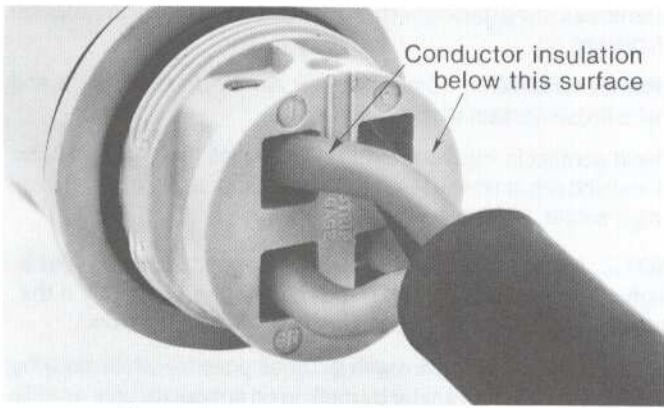

Figure 7. Conductor Installation

### PLUG ASSEMBLY

1. Slide clamping nut over plug sleeve then rethread handle body onto plug sleeve until body seats firmly against O-ring seal and alignment notches on handle body and plug sleeve are aligned. Tighten handle body set screw securely to 7 in. lbs. torque.

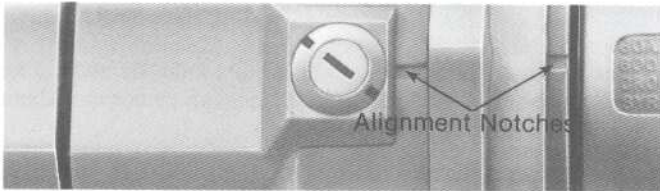

Figure 8. Alignment Notches

2. Slide internal elastomeric cord seal down cord until it seats into the handle body. Slide cord compression basket against inner seal.
3. Rethread gland nut onto handle body tight enough to firmly squeeze the cord compression basket against the cord. While tightening the gland nut, push in on the cord to relieve strain at the contact terminals. Tighten 30 amp gland nut to 12 ft. lbs. torque, 60 amp gland nut to 20 ft. lbs. torque and 100 amp gland nut to 25 ft. lbs. torque. Tighten gland nut set screw securely to 7 in. lbs. torque.

**NOTE:** While tightening the gland nut you will feel a "ratcheting" action. This action is built into the gland nut/cord compression basket fit to resist turning once the plug is assembled.

4. Slide external cord seal down cord and insert into recessed groove in gland nut.

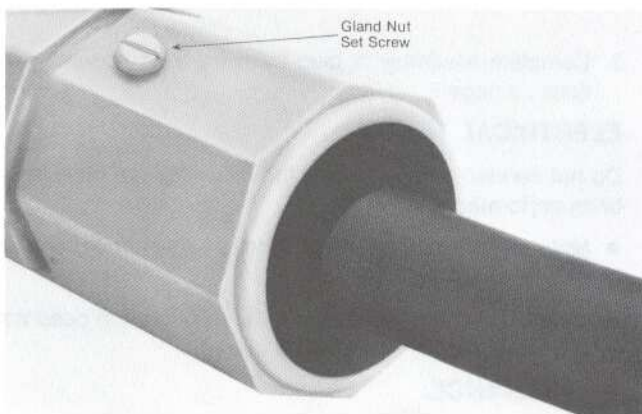

Figure 9. External Cord Seal

### CRIMP/SOLDER TERMINATION

NPJ Series plugs with Crimp/Solder Termination are identified through the addition of a suffix T to the Catalog Number. See Table 4 for proper wire sizes.

1. Remove all contacts (except the grounding contact) from the plug sleeve in NPJ plugs that require crimp or solder contact terminations. To remove the contacts, insert a flat blade screwdriver into the contact recess, depressing the contact retaining clip. While depressing the retaining clip, push on the contact from the opposite end removing the contact. Remove retaining clips from contacts and retain for reassembly. See Figure 10.

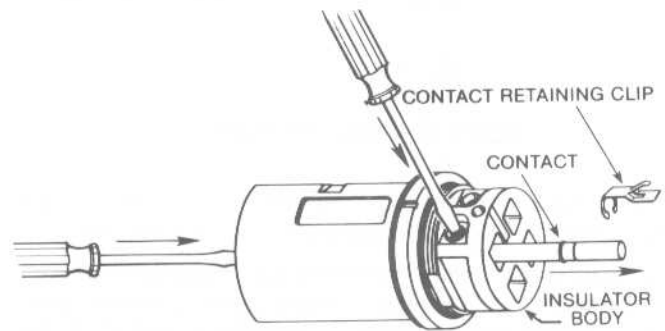

Figure 10. Contact Removal (Crimp or Solder Contacts)

2. Follow steps 1 through 6 of Cord Connection Instructions on pages 2 and 3.
3. Connect the conductors into each contact wire well by either crimp or solder connection, following the established system wiring pattern. Grounding conductors are not crimped or soldered but held securely with pressure connector screw.

### Crimp Connection:

Proper crimp termination may require the use of a wire well reducer to ensure a complete metal fill in the crimped joint. Table 4 lists the various wire well reducers and crimping dies to be used with each wire well contact and conductor size.

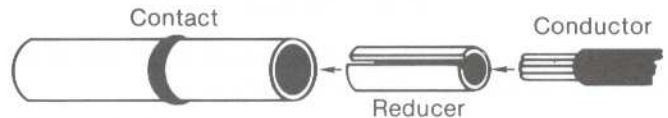

Figure 11. Wire Well Reducer

- Select the proper wire well reducer (supplied with NPJ Series plugs ordered with a "T" suffix on the catalog number), and insert into the contact wire well.
- Insert the conductor and crimp the connection. The recommended Thomas and Betts Company hex crimp dies are listed in Table 4.

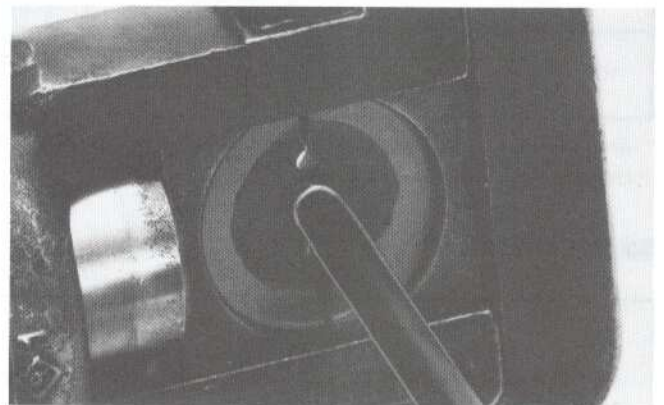

Figure 12.

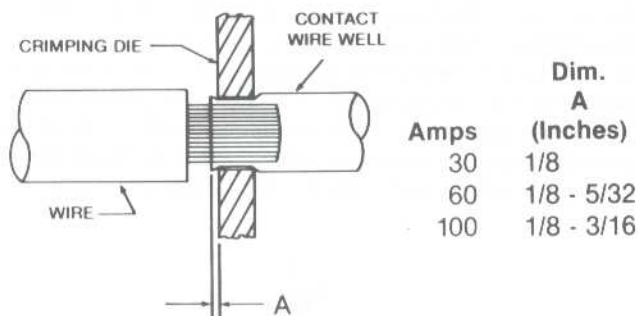

Figure 13. Crimp Connection

- Inspect the crimp connection. The contact should securely grip the conductor without any cracks or tears in the wire well.
- Lubricate contact with silicone grease (e.g. Dow Corning® #111 or General Electric Company Insulgrease® Dielectric Compound #640) making sure that O-ring gasket is intact and free of any dirt or foreign materials.

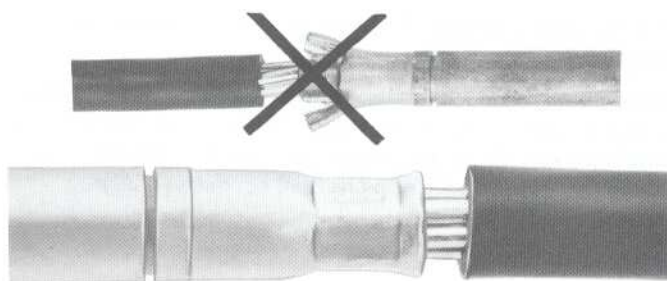

Figure 14. Crimp Connection

TABLE 4  
Crimp Chart for All ARKTITE Plugs & Cord Connectors  
30, 60 & 100 Amp

NOTE: Use Only flexible cord or cables described in the APPLICATION section of this Instruction Sheet

Rating (Amp)	Wire Size (AWG)	Nominal Wire Diameter	Reducer Required		Thomas & Betts Co. Crimp Dies*	
			OD	ID	Code No.	Crimp No.
30	#10	.116	.180	.137	21	11732
	#8	.167	None		21	11732
60	#8	.167	.270	.190	29	11734
	#6	.210	.250	.216	29	11734
100	#4	.266	None		29	11734
	#4	.266	.375	.312	42	11737
	#2	.336	.375	.343	42	11737
	#1**	.378	None		42	11737

\* Use in Thomas & Betts Crimp Tools, Catalog #13642 (Head) #13604 (Pump)

\*\* Use conductor classes G, H, I & M only.

Solder Connection:

**CAUTION**

Do not solder pressure connection type contacts. Use only crimp type contacts for soldering.

- Remove O-ring gasket from the contact and wipe off the silicone lubricant.
- Remove insulation from conductor as shown in Figure 6 and wire brush contact wire well.
- Hold contact in insulated vise with wire well in upright position. Heat and pre-tin the wire well and conductor using a 60-40 rosin core solder. Do not fill well with solder.

NOTE: A high heat source is required for good soldering. Use a high current resistance type. A torch may be used only if the surrounding conductor insulation is adequately protected.

- Insert conductor into wire well as far as possible while applying heat to the well. Add solder by melting on conductor until well fills and a smooth concave surface of solder forms between the cable and well lip.



Figure 15. Solder Connection

- Remove heat but continue to hold the conductor and contact rigid until solder solidifies. A good solder connection is indicated by a bright shiny solder surface.
  - After contact has cooled completely, replace O-ring gasket and relubricate with silicone grease (e.g. Dow Corning® #111 or General Electric Company Insulgrease® Dielectric Compound #640).
4. Following the system wiring pattern, reinstall the contact retaining clip onto each contact, then push each contact through the rear of the plug insulator until the retaining clip snaps into position in the contact recess. Insert the green or grounding conductor into the grounding contact wire well at the same time and securely tighten the pressure connector screw to 30 in. lbs. torque.



Figure 16.

- 5. Complete assembly of plug following Plug Assembly Instructions on page 3.

**ELECTRICAL TESTING**

Do not connect to power until the following electrical tests have been performed.

- Make continuity checks of wiring to verify correct phasing and grounding connections.
- Check insulation resistance to be sure system does not have any short circuits or unwanted grounds.

**MAINTENANCE**

Electrical and mechanical inspection of all components must be performed on a regular schedule determined by the environment and frequency of use. It is recommended that inspection be performed a minimum of once a year.



### WARNING

If any parts of the plug, receptacle or connectors appear to be missing, broken, or shows signs of damage,

#### DISCONTINUE USE IMMEDIATELY.

Replace with the proper replacement part(s) before continuing service.

1. Inspect all contact wire terminals for tightness. Discoloration due to excessive heat is an indicator of a possible problem and should be thoroughly investigated and repaired as necessary.
2. Check grounding and bonding for correct installation and secure connection.
3. Check gaskets for deterioration and replace if necessary.

4. Clean exterior surfaces making sure nameplates remain legible.
5. Inspect gland nut tightness to ensure proper cord gripping.
6. Check tightness of all screws before using.
7. Inspect housings and replace those which are broken.
8. Check contacts for signs of excessive arcing or burning and replace if necessary.

In addition to these required maintenance procedures, we recommend an Electrical Preventive Maintenance program as described in the National Fire Protection Association Bulletin NFPA No. 70B.

### ELECTRICAL RATING

Maximum Voltages: 600 VAC @ 50-400 Hz, 250VDC

Maximum Continuous Current: 30, 60 or 100 Amperes.

---

*All statements, technical information and recommendations contained herein are based on information and tests we believe to be reliable. The accuracy or completeness thereof are not guaranteed. In accordance with Crouse-Hinds "Terms and Conditions of Sale", and since conditions of use are outside our control, the purchaser should determine the suitability of the product for his intended use and assumes all risk and liability whatsoever in connection therewith.*

---

  
**COOPER**

**Crouse-Hinds**

Quality from  
Cooper Industries

Cooper Industries Inc.  
Crouse-Hinds Division  
PO Box 4999  
Syracuse, New York 13221 • U.S.A.

IF865  
Revision 1/93

Copyright © 1992, Cooper Industries, Inc.