

**EPC SERIES  
CIRCUIT BREAKER ENCLOSURE  
WITH INTERLOCKED  
ARKTITE® RECEPTACLE**



**Installation and Maintenance Information  
IF267 5/83**

**APPLICATION**

EPC Series circuit breakers with interlocked ARKTITE receptacle are designed for use as a service outlet to portable electric equipment with the circuit breaker providing overcurrent and short circuit protection. EPC Series circuit breakers are rated at 20, 30, 40, 50, 70, 90 and 100 amperes. The ARKTITE receptacles are rated at 30, 60 and 100 amperes, and provided in 2-wire, 3-pole and 3-wire, 4-pole designs. The receptacles provide attachment of the grounding wire to an extra grounding pole and direct connection between plug and receptacle housings and grounding pole. The polarized receptacle is compatible with APJ, NPJ and CPH Series Style 2 plugs with the same style, current rating and number of poles. EPC Series circuit breakers with interlocked ARKTITE receptacle are designed for use in Class I, Groups C, D; Class II, Groups F, G; and Class III hazardous (classified) areas as defined by the National Electrical Code® (NEC) as well as in damp, wet, or corrosive locations.

30, 60 and  
100-ampere  
size EPC

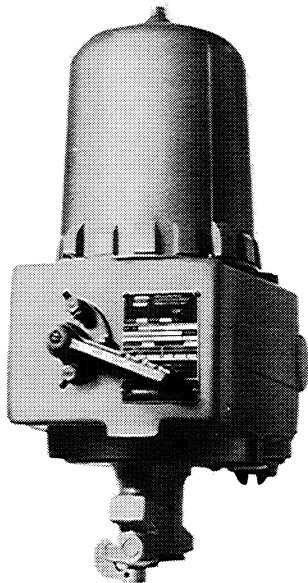

**CAUTION**

To reduce the risk of ignition of hazardous atmospheres, do not use in Class II, Group F locations that contain electrically conductive dusts.

The interlocked receptacle and mating plug cannot be made or broken under load.

The circuit breaker cannot be closed until the plug is fully inserted into the receptacle. When the plug is fully inserted and the circuit breaker closed, the plug cannot be removed until the breaker is opened.

**ENCLOSURE INSTALLATION**

**WARNING**

Electrical power must be **off** before and during installation and maintenance.

1. Install conduit sealing fittings into EPC enclosure hubs before fastening unit to mounting location for installation of conduit and power supply wires.

**CAUTION**

- Hazardous location information specifying class and group listing of each device is marked on the nameplate of each enclosure.
- All unused conduit openings must be plugged. Plug must engage a minimum of five full threads and be a minimum of 1/8 inch thick.
- Conduit sealing fittings must be installed in each attached conduit run to comply with the latest edition of the NEC Section 501-5 and/or 502-5 plus any other applicable code.

2. Select mounting location that will provide suitable strength and rigidity for supporting the unit and all contained wiring. Be sure to provide adequate space for insertion and removal of the plug.
3. Fasten unit to mounting location: Position top keyway slot onto 5/16 inch diameter bolt or lag screw; level unit; then secure bottom at two open slots with 5/16 inch diameter bolts or lag screws. Refer to DIMENSIONS section of these instructions.
4. Depress locking tab and remove top cover using a standard pinch bar or similar tool as a pry between the notches on the rim of the cover and the lug attached to the center section of the enclosure.
5. Install circuit breaker into units supplied without one.
  - Select the proper circuit breaker from Table I.
  - Secure circuit breaker to mounting plate in location indicated on mounting plate label.
  - Secure upper operating rod guide with two upper circuit breaker mounting screws.
  - Adjust operating rod bracket as necessary to captivate circuit breaker toggles.

®National Electrical Code is a Registered Trademark of the National Fire Protection Association.

®ARKTITE is a Registered Trademark of the Crouse-Hinds Company.

6. Install wiring. Refer to WIRING CONNECTION section of these instructions.
7. Check wiring per ELECTRICAL TESTING section of these instructions.
8. Replace top cover.

**CAUTION**

Check for dirt, grit or other foreign material on the threads. If any such material settles on these threads, clear them with kerosene or Stoddard solvent\*, then lubricate with Crouse-Hinds Company Type STL thread lubricant.

(\*To avoid the possibilities of an explosion, oxidation and corrosion, do not use gasoline or similar solvents.)

**WIRING CONNECTION**

**WARNING**

EPC Series enclosures must be securely attached into a permanently grounded conduit system in accordance with Article 250 of the National Electrical Code.

Determine the type of distribution system to be used that will comply with NEC requirements and ensure grounding continuity.

Proper grounding of systems and circuit conductors is required to limit hazardous voltages caused by lightning, line surges or unintentional contact with higher voltage lines and to stabilize the voltage to ground during normal operation. All conductive materials that enclose the electrical conductors or attached equipment or forming part of such equipment must be grounded. A permanent conducting connection must be made between all such equipment and the earth.

Pull all power supply conductors into enclosure and make connections to the line side of the circuit breaker following the wiring pattern established for your system.

**WARNING**

Before installing an EPC Series enclosure with interlocked ARKTITE receptacle, a wiring pattern must be established for your system. Locations having different voltages, frequencies or types of current (AC or DC) **MUST NOT** have interchangeable attachment plugs as stated in paragraph 210-7F of the National Electrical Code.

The ARKTITE receptacles on the EPC enclosures are polarized so that mating plugs can enter the receptacle only one way. Also, the mating contacts in the receptacle and corresponding plug are identified by numbers on the insulating recesses. **Note:** Some ARKTITE plugs manufactured prior to 1982 identify the mating contacts by color. Contact members in the receptacle always mate with those in a plug identified by the same number (or color). This assures proper polarity or phase rotation of conductors through receptacle and plug.

Usually the conductors in a cable or conduit system are identified by the color of the insulation covering each individual conductor. We assume that these colors agree with those given in Section 210-5 of the National Electrical Code for multi-wire branch circuits; also, that there is an additional wire in the cable or conduit system that is uninsulated or identified green that is for grounding and complies with Sections 250-42 and 250-45 of the National Electrical Code. If the conductors are not identified with exactly these colors, these colors may be assumed when making proper connections.

**WARNING**

For each system the same colored wire must be attached to the same numbered (or color coded) contact on all plugs and receptacles in that system. This will assure correct system polarity and reduce the possibility of equipment damage and/or personal injury due to mis-phasing or electrical shorts. Always test before energizing.

**Table I. EPC ENCLOSURE**

EPC ENCLOSURE w/RECEPTACLE				CIRCUIT BREAKER		
Receptacle Style	Receptacle Rating	Catalog Number	Hub Size (In.)	Rating* (Amp.)	Westinghouse "EHB" Catalog Number	General Electric "TED" Catalog Number
30 amp. 2-wire, 3-pole, Style 2	2-pole, 480 VAC or 250 VDC	EPC43032	1-1/4	20	EHB2020L	TED124020-WL
				30	EHB2030L	TED124030-WL
				40*	EHB2040L	TED124040-WL
				50*	EHB2050L	TED124050-WL
30 amp. 3-wire, 4-pole, Style 2	3-pole, 480 VAC or 250 VDC	EPC43042	1-1/4	20	EHB3020L	TED134020-WL
				30	EHB3030L	TED134030-WL
				40*	EHB3040L	TED134040-WL
				50*	EHB3050L	TED134050-WL
60 amp. 2-wire, 3-pole, Style 2	2-pole, 480 VAC or 250 VDC	EPC46032	1-1/4	50	EHB2050L	TED124050-WL
		EPC66032	2	70*	EHB2070L	TED124070-WL
				90*	EHB2090L	—
60 amp. 3-wire, 4-pole, Style 2	3-pole, 480 VAC or 250 VDC	EPC46042	1-1/4	50	EHB3050L	TED134050-WL
		EPC66042	2	70*	EHB3070L	TED134070-WL
				90*	EHB3090L	—
100 amp. 2-wire, 3-pole, Style 2	2-pole, 480 VAC or 250 VDC	EPC61032	2	100*	EHB2100L	TED124100-WL
				70	EHB2070L	TED124070-WL
				90	EHB2090L	—
100 amp. 3-wire, 4-pole, Style 2	3-pole, 480 VAC or 250 VDC	EPC1042	2	100	EHB2100L	TED124100-WL
				70	EHB3070L	TED134070-WL
				90	EHB3090L	—
				100	EHB3100L	TED134100-WL

**\*CAUTION**

Selecting a circuit breaker with an ampere rating exceeding that of the ARKTITE® receptacle must only be done where a momentary in-rush current can be caused by heavy, slow-starting loads, but where the normal continuous operating current is less than the receptacle rating.

If all conductors are alike except one, that one may be assumed to be white and all the others will probably be in the same relative location from the white wire at the other end of the same cable. **However**, lacking positive color identification of each conductor, **ALWAYS** test them out electrically.

Assuming conductor color identification as described earlier, connect conductors identified by color in the proper column in Table II through corresponding contacts in the plug and receptacle identified by number (or color) listed. The white wire should always be connected through the #2 contact (or white color code).

**Table II.**

Receptacle Style	Color of Conductors	Receptacle and Plug Contact Identification		Circuit Breaker Line Connections
		by Number	by Color***	
2-wire, 3-pole	White*	Contact #2	White	L1
	Black	Contact #1	Red	L2
	Green**	GR (grounding contact)	Unidentified	Ground
3-wire, 4-pole	White*	Contact #2	White	L2
	Black	Contact #3	Orange	L1
	Red	Contact #1	Red	L3
	Green**	GR (grounding contact)	Unidentified	Ground

\*White wire or terminal must not be used for grounding. If one conductor is uninsulated, or identified green, this wire is for grounding the portable device. If no green or bare wire is available, another wire may be connected through plug and receptacle connections to conduit or some other non-current-carrying conductor permanently grounded in accordance with Article 250 of the 1981 National Electrical Code.

\*\*Use pressure type termination.

\*\*\*AKRTITE® plugs manufactured prior to 1982.

**NOTE:** EPC enclosures identified with the addition of Suffix S4 to catalog number are supplied with receptacle contacts rotated 22-1/2 degrees for special polarity applications. They are compatible only with plugs built with the same special feature.

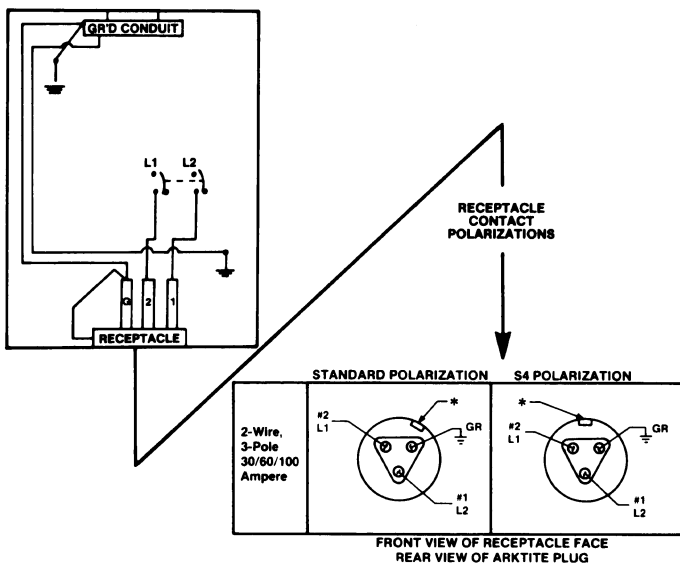

\* POLARIZATION KEYWAY OR KEY  
(Keyway is groove, key may be extended form or rivet.)

**Figure 1.**  
2-wire, 3-pole, Style 2 Contact Identification

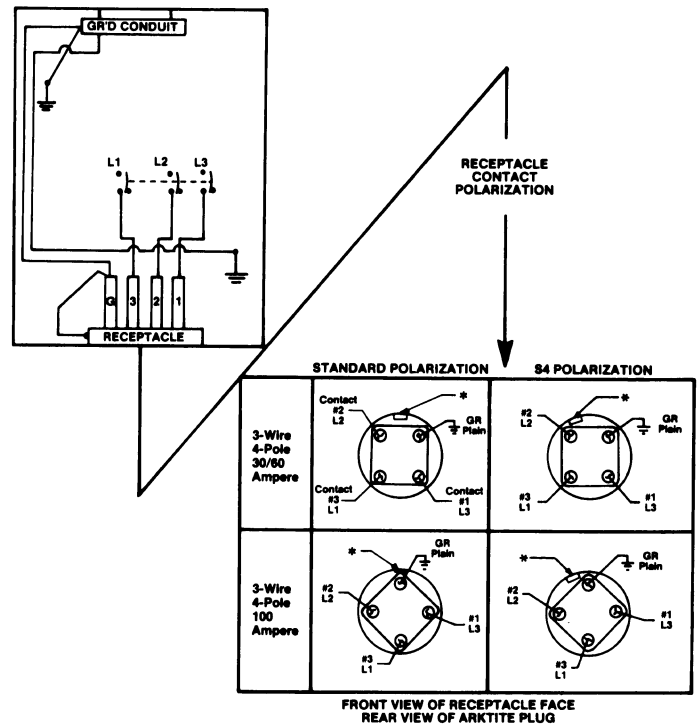

\* POLARIZATION KEYWAY OR KEY  
(Keyway is groove, key may be extended form or rivet.)

**Figure 2.**  
3-wire, 4-pole, Style 2 Contact Identification

**DIMENSIONS**

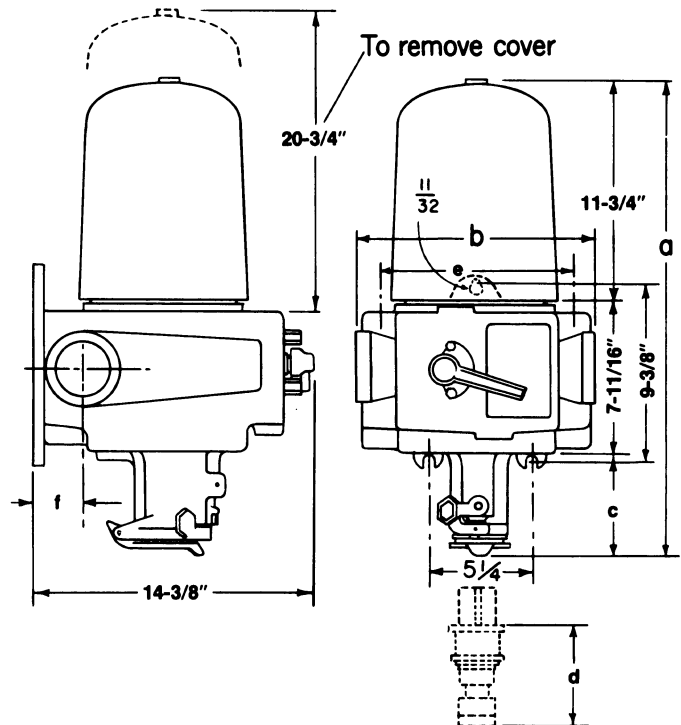

Recept.	Breaker	a	b	c	d	e	f
30 Amp.	20-50 Amp.	24	10-5/8	4-9/16	4-3/4	7-3/8	2-1/16
60 Amp.	50 Amp.	24-1/2	10-5/8	5-1/16	5-1/4	7-3/8	2-1/8
60 Amp.	70-100 Amp.	24-1/2	12-13/16	5-1/16	5-1/4	9-1/4	2-5/8
100 Amp.	70-100 Amp.	25-1/4	12-13/16	5-13/16	7-1/4	9-1/4	2-5/8

Dimension "d" is exposed portion of plug when engaged with receptacle.

## ENCLOSURE DISASSEMBLY

### WARNING

Electrical power must be turned **off** before and during disassembly or maintenance.

1. Remove top cover.
2. Disconnect supply conductors attached to line side of circuit breaker and those connecting the receptacle to load side of circuit breaker.
3. Remove two screws attaching upper operating rod guide to the upper circuit breaker mounting bracket.
4. Loosen **BUT DO NOT REMOVE**, the four set screws holding the two mounting bracket shoes to the center section of the enclosure until the shoes are free to pivot. Remove circuit breaker mounting bracket assembly.
5. Remove operating rod assembly by pressing assembly towards receptacle and rotating clockwise until it is free from operating arm shaft.
6. Align square hole with interlock shaft and then remove operating rod assembly.

### CAUTION

Note depth that receptacle housing enters EPC enclosure housing for reference when reassembling later.

7. Remove the aligning and locking plate fastened to flat surface on right side of the receptacle. Unscrew receptacle assembly from EPC enclosure.

## ENCLOSURE ASSEMBLY

1. Replace receptacle assembly. Be sure that receptacle is rethreaded into enclosure to the original depth noted previously.
2. Place aligning and locking plate over 1/4 inch pin on center section of enclosure and fasten plate to receptacle assembly using the two slotted hex head screws.
3. With release lever in the depressed position, replace the circuit breaker operating rod assembly.
4. Replace the circuit breaker mounting frame, circuit breaker and operating rod guide.
5. Test the interlock mechanism, complete all wiring connections and replace upper cover.

## INTERLOCK TEST

With the ARKTITE® plug removed from the receptacle it should be impossible to move operating handle to "on" position.

Insert plug into receptacle. This should actuate the interlocking mechanism and allow the operating handle to be moved to ON position. The plug at this time should resist all normal efforts to withdraw it from the receptacle even while pressing the release lever.

Move operating handle to OFF position, press release lever and withdraw the plug. It should again be impossible to move the operating handle to the ON position.

## ELECTRICAL TESTING

Do not connect to power until the following electrical tests have been performed:

- Make continuity check of wiring to verify correct phasing and grounding connections.
- Check insulation resistance to be sure system does not have any short circuits or unwanted grounds.

## MAINTENANCE

Electrical and mechanical inspection of all components must be performed on a regular schedule determined by the environments and frequency of use. It is recommended that inspection be performed a minimum of once a year.

### WARNING

If any parts of the plug, receptacle or connectors appear to be missing, broken, or show signs of damage, **DISCONTINUE USE IMMEDIATELY**. Replace with the proper replacement part(s) before continuing service.

1. Inspect all wire terminals for tightness. Discoloration due to excessive heat is an indicator of a possible problem and should be thoroughly investigated and repaired as necessary.
2. Check grounding and bonding for correct installation and secure connection.
3. Clean exterior surfaces making sure nameplates remain legible.
4. Inspect housings and replace those which are broken.
5. Check receptacle contacts for signs of excessive arcing or burning and replace if necessary.

In addition to these required maintenance procedures, we recommend an Electrical Preventive Maintenance program as described in the National Fire Protection Association Bulletin NFPA No. 70B.

All statements, technical information and recommendations contained herein are based on information and tests we believe to be reliable. The accuracy or completeness thereof are not guaranteed. In accordance with Crouse-Hinds

"Terms and Conditions of Sale", and since conditions of use are outside our control, the purchaser should determine the suitability of the product for his intended use and assumes all risk and liability whatsoever in connection herewith.

**This instruction sheet should be retained for future use in maintenance.**