

# GFS-K1 & GFS-K2 Replacement Ground Fault Circuit Interrupters

## Installation & Maintenance Information

**IF 1411**

SAVE THESE INSTRUCTIONS FOR FUTURE REFERENCE

### IMPORTANT INFORMATION

A GFS ground fault circuit interrupter reduces the hazards of ground fault currents that can cause loss of life. Upon detecting a ground fault current (exceeding 5 milliamps) in the protected branch circuit, the GFS unit will trip, interrupting power. Even with GFS unit limiting ground fault current, some electrical shock may be felt. Such shock will normally be of less than dangerous duration. However, persons with heart problems or other medical conditions that may make that person susceptible to the effects of electrical shock may still be seriously injured. While the GFS ground fault circuit interrupter provides a significant level of protection, there is no known device that can provide complete protection from all hazards of electrical accidents under all conditions.

The GFS unit will not protect against short circuits or overloads. A circuit breaker or fuse controlled switching system that supplies power to the branch circuit must provide that protection.

When the GFS unit has interrupted a ground fault current caused by faulty insulation, defective equipment or wet wiring, the fault must be repaired before the GFS unit is reset. The GFS unit must be tested upon completion of initial installation and at regular intervals in an established testing program.

### APPLICATION

GFS ground fault circuit interrupter is used with portable electrical equipment to protect against possible injury due to unwanted ground faults, meeting the requirements for personnel protection as defined by the National Electrical Code® (NEC) and the Canadian Standards Association. When mounted on proper body, no additional sealing is required. A factory sealed chamber encloses the unit in a housing with explosion-proof ground joints. GFS Interrupter is suitable for use in Class I, Groups C and D, Class II, Groups E, F, and G, and Class III hazardous (classified) areas as defined by the National Electrical Code.

GFS ground fault interrupter is a feed through type to serve receptacles in a branch circuit of 15 to 20 ampere at 125 volts AC. They are intended for use with Crouse-Hinds ENR or CPS152 receptacles.

**⚠ CAUTION**

Do not install in corrosive areas or areas exposed to rain, hosedown or water runoff.

®National Electrical Code is a Registered Trademark of the National Fire Protection Association

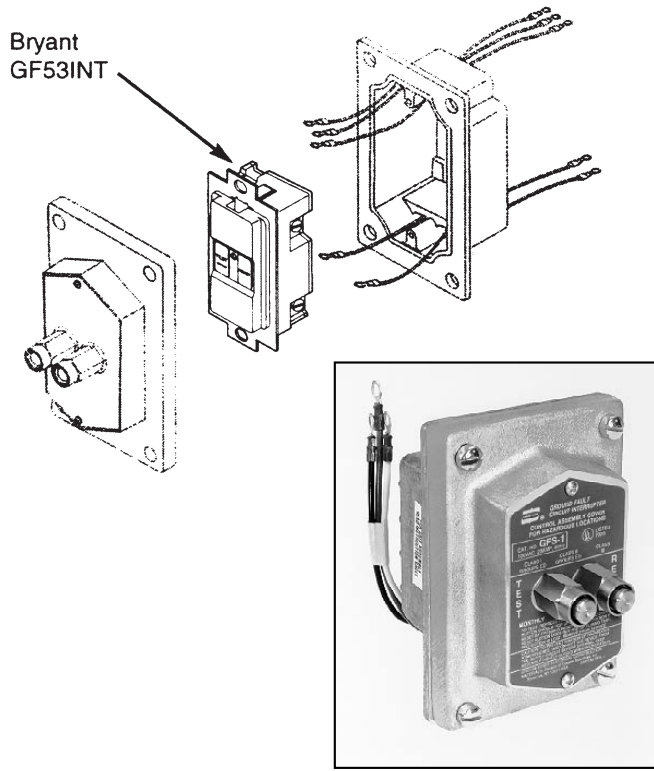

**GFS-K1**

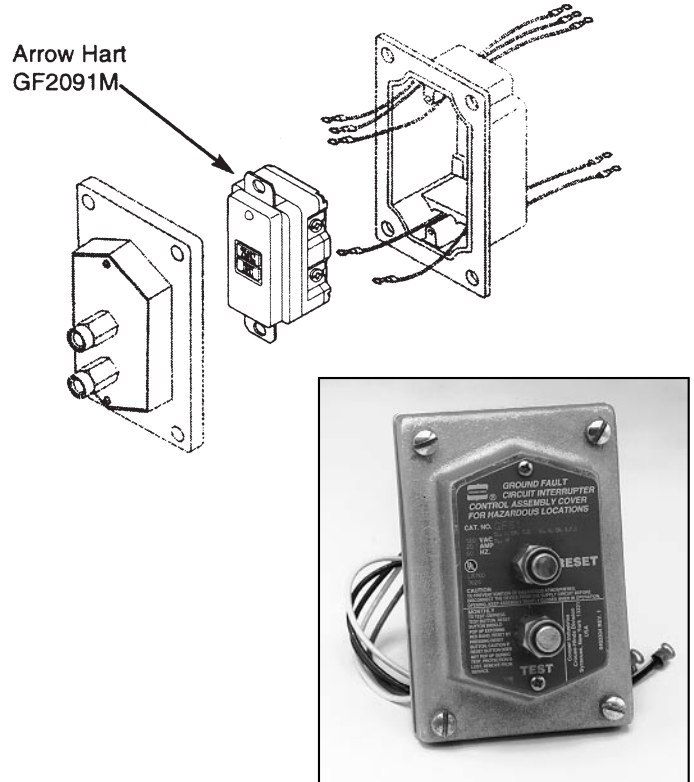

**GFS-K2**

## INSTALLATION

Before starting, read all instructions contained in this installation and maintenance information sheet.

### CAUTION

Be sure all electrical power is OFF before starting installation and maintenance.

Install on 120 VAC grounded circuit only that is protected by properly rated circuit breaker or fuse.

1. Remove four cover screws and set cover assembly aside carefully to avoid damaging ground-joint surface.
2. Remove two screws retaining GFCI device in sealing chamber and set aside.
3. Holding sealing chamber in device body, pull GFCI device out of the sealing chamber. Attached wires were looped in chamber to facilitate GFCI replacement.
4. Before removal of wires, note orientation of test/reset buttons in chamber. They must align with "test" and "reset" pushbuttons on front of cover – either side-by-side or top and bottom positions.
5. Remove break-off tabs on GFCI device to be installed.
6. Caution: Line and load terminations on replacement GFCI device may not be the same as device in sealing chamber with relation to front buttons.
7. Before installing device, refer to installation instructions provided with GFCI device.
8. Attach wires to device and securely tighten terminal & ground screws to 14 in/lb.
9. Reinstall device into sealing chamber, pushing device inward carefully to avoid damaging wires. Securely tighten device using the screws provided.
10. Insert wiring, then factory sealed chamber into device box with internal TEST and RESET buttons positioned correctly. TEST button on external cover MUST be lined up with TEST button of device in sealing well (clearly marked).
11. Place external cover over factory sealed chamber per Step 10 and attach with the four screws provided. Tighten screws to 30 inch-pounds torque.

### CAUTION

Clean both ground-joint surfaces of cover, internal sealing chamber and device box before tightening screws. Dirt or foreign material must not accumulate on flat ground-joint surfaces. Surfaces must fully seat against each other to form a proper explosion-proof seal.

12. Do not use GFS unit until it has been fully and successfully tested as specified in TESTING PROCEDURE.

## TESTING PROCEDURE

### WARNING

If receptacle to be tested is located in a normally hazardous area, that area must be purged of the hazard and declared nonhazardous before starting testing procedure.

1. Turn power ON to branch circuit receptacle protected by GFS unit.
2. Press the TEST button on GFS unit, the RESET button should extend outward displaying a red O-ring.
3. Plug a test lamp or meter into a protected receptacle. If the test lamp lights (or meter indicates a voltage reading), this indicates that the connections have been wired incorrectly. Turn off power to circuit and correct wiring before proceeding further. If the test lamp does not go on, or meter indicates zero voltage reading, proceed to the next step.
4. Press the RESET button firmly until an audible click is heard. The test lamp should now turn on. Press the TEST button again. The Test lamp should go OFF and RESET button extend outward. This indicates proper wiring connection to that receptacle.
5. With the RESET button extended, test the other receptacles in the branch circuit protected by the GFS unit. If the test lamp lights or the meter indicates a voltage reading, this indicates that the receptacle is NOT protected by the GFS unit. Turn power OFF to circuit and correct the wiring. Test all receptacles protected by the GFS unit.
6. Attach the self-adhesive "GROUND FAULT PROTECTED" label to each receptacle protected by the GFS unit.
7. Establish and maintain a regular monthly testing schedule.

---

*All statements, technical information and recommendations contained herein are based on information and tests we believe to be reliable. The accuracy or completeness thereof are not guaranteed. In accordance with Crouse-Hinds "Terms and Conditions of Sale", and since conditions of use are outside our control, the purchaser should determine the suitability of the product for his intended use and assumes all risk and liability whatsoever in connection therewith.*

---