

WSR Series, Model M94 Enclosed Switches with Interlocked Arktite™ Receptacles

Installation & Maintenance Information

SAVE THESE INSTRUCTIONS FOR FUTURE REFERENCE

APPLICATION

WSR Series enclosed disconnect switches with interlocked ARKTITE receptacles are designed to provide connection and distribution of secondary electrical power (600 volts or less) between a power source and portable or stationary electrical equipment. Fusible Type WSR switches also provide short circuit protection. WSR Series switches with interlocked ARKTITE receptacles are supplied in both 3-wire, 3-pole fusible and non-fusible arrangements with Style 1 grounding where ground is connected through the shell; and 3-wire, 4-pole fusible and non-fusible arrangements with Style 2 grounding where ground is connected through an extra pole and the shell. Refer to Crouse-Hinds Product Catalog for a detailed description of these grounding methods.

WSR Series switches are interlocked both with the enclosure door and ARKTITE receptacle. The plug cannot be withdrawn or inserted unless the switch is open (OFF). The enclosure cover cannot be opened when plug is engaged and the switch is closed (ON). When the switch is open (OFF) the switch cannot be put in a closed (ON) position with the door open.

The ARKTITE receptacles supplied with the WSR series enclosures are polarized to prevent mis-matching. Each enclosure is used with specific Crouse-Hinds APJ, NPJ, CPH, and CPP Series ARKTITE plugs with the same electrical ratings, grounding style and contact configurations. Refer to CrouseHinds Product Catalog for a complete listing of compatible WSR Series Interlocked ARKTITE receptacles and matching ARKTITE plugs.

WSR Series enclosed disconnect switches and Interlocked ARKTITE receptacles may be pole mounted or installed on flat vertical surfaces. WSR Series products are designed for use in industrial areas that are subjected to dust, dirt, chemical vapors or moisture, both indoors or outdoors.

⚠ CAUTION
The WSR Series enclosure should be installed, inspected, operated and maintained by qualified and competent personnel.

DIMENSIONS

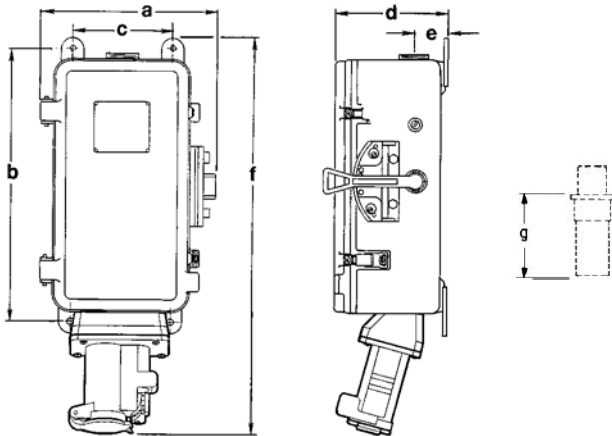

WSR Dimensions (In.)			
Amps	30	60	100
a	11-3/4	11-3/4	14-7/8
b	20-1/16	20-1/16	26-5/16
c	6-9/16	6-9/16	9-9/16
d	7-1/4	7-1/4	8-1/4
e	2-15/32	2-15/32	2-7/8
f	27-11/16	28-11/16	35-3/8
g	4-3/4	5-1/4	7-1/4
Mtg. Holes	3/8	3/8	7/16
Dim. "g" is exposed portion of plug when engaged with receptacle			

INSTALLATION

⚠ WARNING
Electrical power must be turned **OFF** before and during installation and maintenance.

- Select a mounting location that will provide suitable strength and rigidity for supporting the enclosure. Fasten unit to mounting location with the four mounting lugs using 3/8 inch diameter mounting bolts or screws. The mounting lugs may be rotated 90 degrees or moved to the vertical center line position for pole mounting.
- Always locate enclosure in vertical position with receptacle contacts pointing downward.
- The recommended mounting height from ground or floor level to the bottom of the receptacle is 42 to 52 inches.

⚠ WARNING
WSR receptacle housing must be securely attached into a permanently grounded system in accordance with Article 250 of the national Electrical Code.

- Determine the type of distribution system to be used that will comply with NEC requirements and ensure grounding continuity.

Proper grounding of systems and circuit conductors is required to limit hazardous voltages caused by lightning, line surges or unintentional contact with higher voltage lines and to stabilize the voltage to ground during normal operation. All conductive materials that enclose the electrical conductors or attached equipment or forming part of such equipment must be grounded. A permanent conducting connection must be made between all such equipment and the earth. Typical distribution systems are illustrated in Figure 1.

Typical distribution systems are illustrated below:

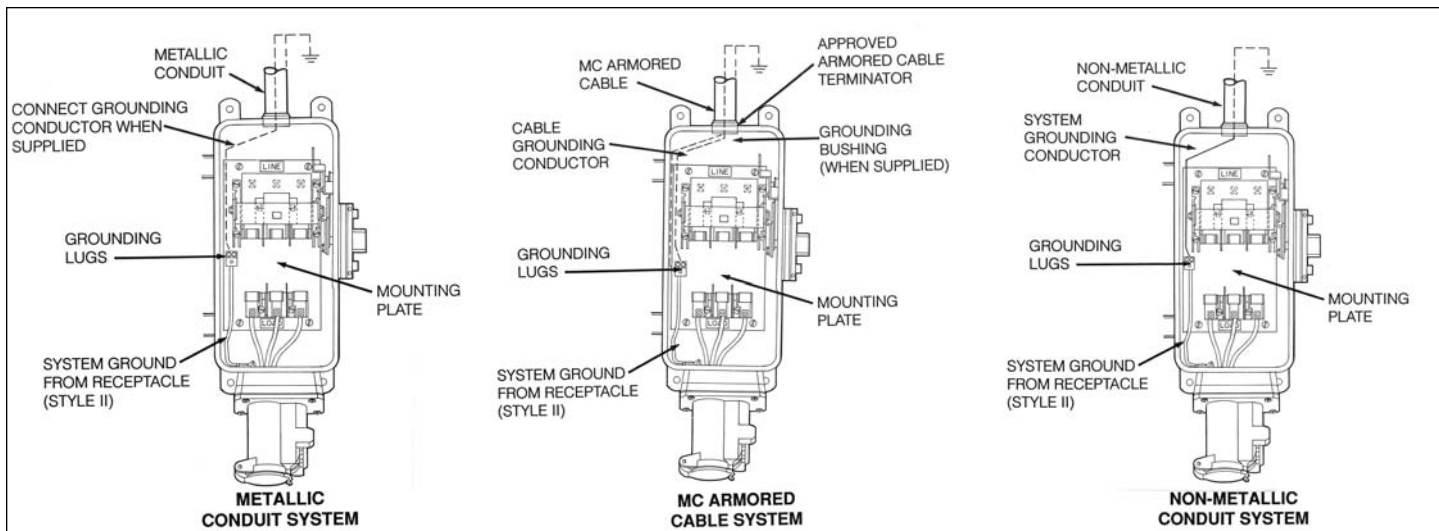

Figure 1. Grounding Systems

- Attach enclosure into electrical distribution system to ensure equipment grounding continuity. See Table 1 for conduit opening sizes. Conduit openings are furnished with a reducer which may be removed to obtain a larger opening. The locknut and bushing must meet the requirements of the National Electrical Code.

WSR Rating (amp)	Conduit Openings	
	with reducer	without reducer
30	1	1-1/2
60	1-1/4	1-1/2
100	1-1/2	2

Table 1 Conduit Openings

WIRING CONNECTIONS

- Establish a wiring pattern for your system.

⚠ WARNING

Before installing a WSR Series enclosed disconnect switch and interlocked ARKTITE receptacle, a wiring pattern must be established for your system. Locations having different voltages, frequencies or types of current (AC or DC) **MUST NOT** have interchangeable attachment plugs as stated in paragraph 406.4(6)(F) of the National Electrical Code.

- Connect grounding conductor when used. Pull all phase conductors into enclosure and make connections to the line side pressure connector terminations following the wiring pattern established for your system. See Figure 2.
- Check plug/receptacle polarization.

The ARKTITE receptacles on the WSR enclosures are polarized so that mating plugs can enter the receptacle only one way. Also, the mating contacts in the receptacle and corresponding plug are identified by numbers on the insulating recesses. Note: Some ARKTITE plugs manufactured prior to 1982 identify the mating contacts by color. Contact members in the receptacle must always mate with those in plug identified by the same number (or color).

This assures proper polarity or phase rotation of conductors through receptacle and plug.

Before energizing this system, verify polarity correctness with a continuity check. Correct polarity **MUST** be ascertained

before using the equipment. Check insulation resistance to be sure system does not have any short circuits or unwanted grounds.

- Install proper rated cartridge fuses (not included with unit) where used. The units are arranged for National Electrical Code Class H fuses, however, the 60 ampere rated units only may be field converted to Class J fuses.
- Test wiring for correctness with continuity checks and for unwanted grounds with insulation resistance tester.
- Place operating handle in open (OFF) position then close cover and secure with two compression spring draw pull catches.

Line Pressure Connection Terminations

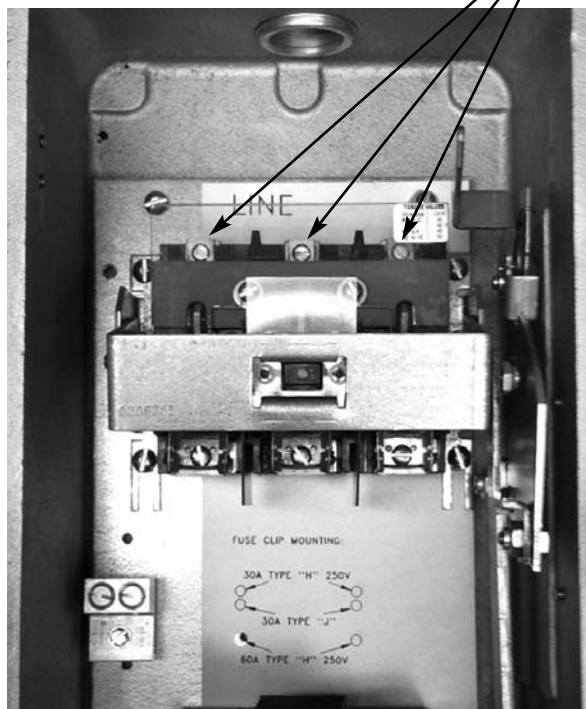

Figure 2. WSR Interior (Fusible Type Shown)

- Before turning on power to WSR enclosure, check safety interlock mechanism for proper operation.
- The plug cannot be inserted or withdrawn unless the switch is open (OFF).
 - The enclosure door cannot be opened when the plug is inserted and the switch closed (ON). When the switch is open (OFF), it cannot be put in a closed (ON) position with the door open.

⚠ CAUTION
Forcing the switch operator handle mechanism without using proper ARKTITE plug or with enclosure door open will damage safety interlocks.

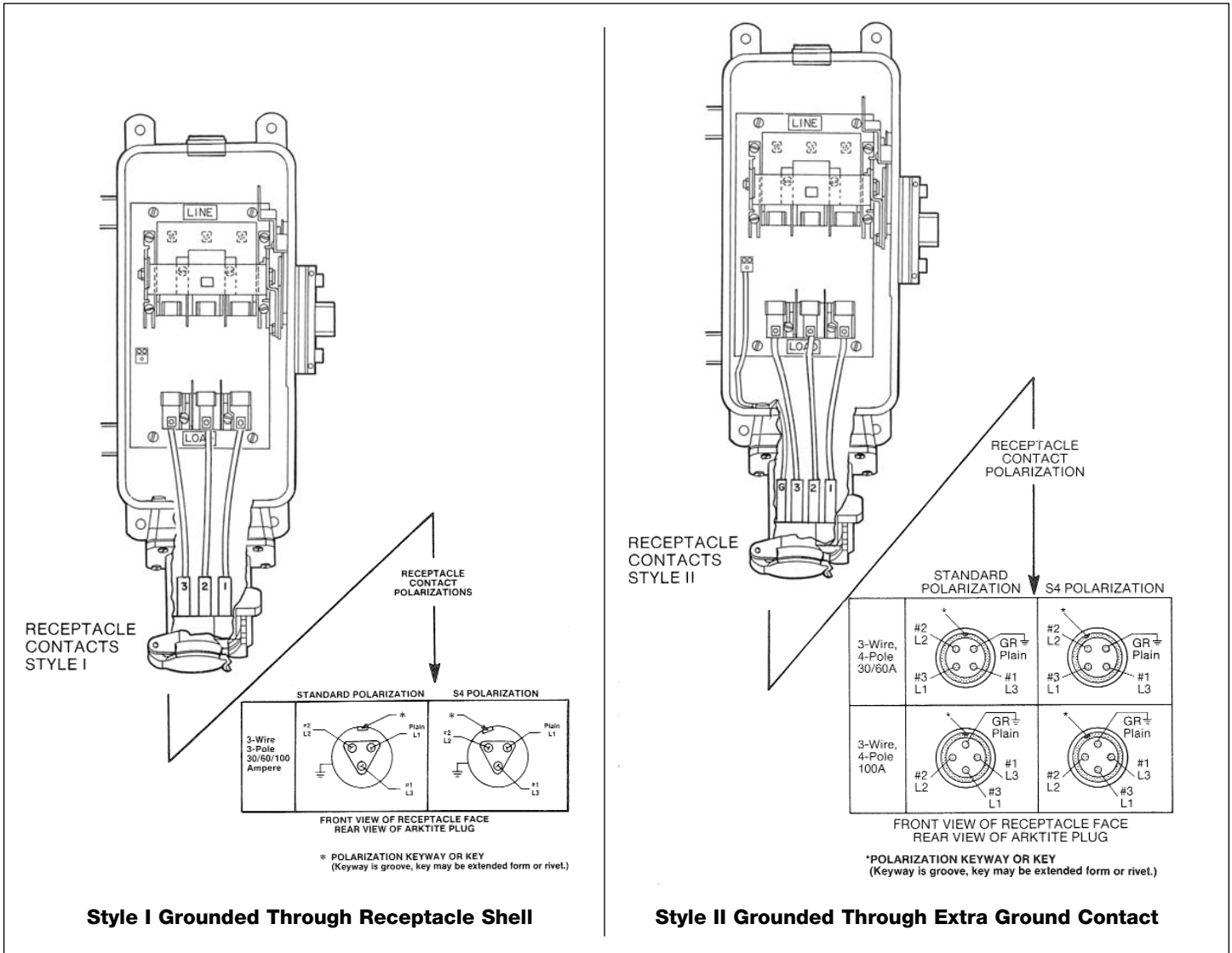

Figure 3. Contact Polarization

MAINTENANCE

⚠ WARNING
Always disconnect primary power source before opening enclosure for inspection or service.

- Frequent inspection should be made. A schedule for maintenance check should be determined by the environment and frequency of use. It is recommended that it should be at least once a year. We recommend an Electrical Preventive Maintenance program as described in the National Fire Protection Association Bulletin NFPA No. 70B.
 - Perform visual, electrical, and mechanical checks on all components on a regular basis.
- Visually check for undue heating evidenced by discoloration of wires or other components, damaged or worn parts, or leakage evidenced by water or corrosion in the interior.

- Electrically check to make sure that all connections are clean and tight, and that blade contacts make of break as required.
- Mechanically check that all parts are properly assembled, interlocks working, and operating mechanisms move freely.

⚠ WARNING
If any part of the switch, receptacle and/or plug appears to be broken or damaged,
DISCONTINUE USE IMMEDIATELY.
Replace, or properly repair the item before continuing service.

All statements, technical information and recommendations contained herein are based on information and tests we believe to be reliable. The accuracy or completeness thereof are not guaranteed. In accordance with Crouse-Hinds "Terms and Conditions of Sale", and since conditions of use are outside our control, the purchaser should determine the suitability of the product for his intended use and assumes all risk and liability whatsoever in connection therewith.
