



EPC SERIES (200 AMP) CIRCUIT BREAKER INTERLOCKED RECEPTACLE REPLACEMENTS

Receptacle Parts Pg. 3,
Enclosure Parts Pg. 3-4

Installation and Maintenance Information

APPLICATION

EPC Series circuit breakers with interlocked receptacles are designed for use as a service outlet to portable electric equipment with the circuit breaker providing overcurrent and short circuit protection. EPC Series circuit breakers are rated at 125, 150, 175, and 200 amperes. The receptacle is rated at 200 amperes, and provided in 3-wire, 4-pole design. The receptacle provides attachment of the grounding wire to an extra grounding pole and direct

connection between plug and receptacle housings and grounding pole. The polarized receptacle is compatible with a DP20468 Style 2 plug. EPC Series circuit breakers with interlocked receptacles are designed for use in Class I, Group D; Class II, Groups F, G; and Class III hazardous (classified) areas as defined by the National Electrical Code® (NEC) as well as in damp, wet, or corrosive locations.

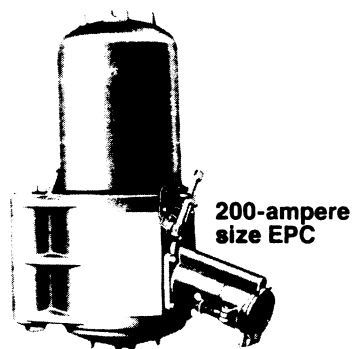

CAUTION:

- To reduce the risk of ignition of hazardous atmospheres, do not use in Class II, Group F locations that contain electrically conductive dusts.

The receptacle and plug are provided with a mechanical interlock to prevent withdrawing the plug when the breaker is turned "ON" and to prevent turning the breaker "ON" if a plug is not inserted into the receptacle.

WARNING

- Forcibly overriding this interlock can result in explosion or electrocution.

INSTRUCTIONS FOR REPLACEMENT OF EPC602-2042R RECEPTACLE ON EPC604-2042/EPC605-2042 SERIES ENCLOSURES

WARNING

- Electrical power supply to breaker must be OFF before and during installation and maintenance.

1. To remove EPC602-2042R receptacle.
 - Remove covers from each end of EPC enclosure.
 - Disconnect receptacle conductors to circuit breaker.
 - Disconnect receptacle ground conductor, wrench off 1/2-13 hex nut holding ground lug (inside enclosure attached to receptacle mounting bolt).

- Wrench off jam nut that was under ground lug.
- Remove the four 1/2-13 hex head bolts which hold the EPC602-2042R receptacle to the enclosure.

CAUTION

- Hammers or prying tools must not be allowed to damage the flat ground joint surfaces. Do not damage or scratch the flat ground joint surfaces of the enclosure or receptacle.

2. Replacement receptacle assembly is factory adjusted. **DO NOT ADJUST**; no adjustments to receptacle are required.

3. Inspect replacement receptacle.

- Examine ground joint surfaces.

CAUTION

- Clean both ground joint surfaces of enclosure and receptacle. Dirt or foreign material must not accumulate on flat ground joint surfaces. Surfaces must seat fully against each other to provide a proper explosionproof seal.

- Push and release interlock rod to verify free, non-binding operation.

4. Install Replacement Receptacle.

- Be sure circuit breaker operating handle is in "OFF" position.
- Position receptacle on enclosure. Replace four 1/2-13 hex bolts. The longest bolt is located in the upper right hand corner of the receptacle flange. Start all threads by hand before wrenching any bolts tight. Torque to 40-45 ft-lbs.
- Wrench jam nut onto longest bolt. Prevent bolt from turning while doing so.
- Replace receptacle ground conductor lug on long bolt, inside enclosure. Secure with 1/2-13 hex nut.

5. Engage plug fully, and switch breaker to "ON" position.

WARNING

- Electrical power supply to breaker must be OFF before and during installation and maintenance.

6. Check receptacle interlocked rod end clearance to cam (See Fig. 1). Clearance should be $1/16$ to $3/16$ ". If not, adjust cam according to INSTRUCTIONS FOR CAM ADJUSTMENT below. (DO NOT ADJUST RECEPTACLE)

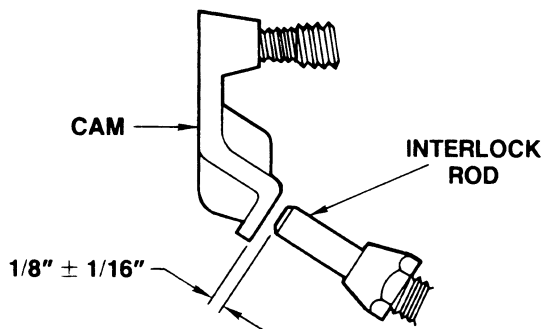

Figure 1 CAM to Interlock Rod Spacing

INSTRUCTIONS FOR CAM ADJUSTMENT

1. Insert plug and switch breaker to "ON" position.
2. Estimate distance between cam and end of interlock rod. (See Fig. 1)
3. Remove circuit breaker operating handle (exterior) by wrenching off 5/16-18 bolt securing handle to shaft.
4. Remove cam from operating shaft by wrenching off 1/4-20 bolt securing cam to shaft.
5. Rotate shaft in or out to set distance between cam and interlock rod to $1/16$ " to $3/16$ " (cam adjustment will move $3/32$ inch for each full turn of shaft).
6. Replace cam on end of shaft (casting part number on cam faces shaft). Recheck spacing between cam and end of interlock rod. Repeat above procedure if measurement is not $1/16$ " to $3/16$ ".
7. Reattach operating handle on operating shaft in "ON" position against left stop. Be sure handle "ON" marking is to the left. Secure with 5/16-18 x 5/8 hex bolt and lock washer.
8. Turn breaker "OFF" and withdraw plug. Move breaker operating bail to take up all linkage slack; this will rotate the cam as close as possible to the interlock rod. The side of the cam should be close to, but not quite touching the interlock rod.
9. If necessary, adjust length of operating rod. To adjust length of operating rod, remove retaining ring on end of operating rod and slip rod from hole in cam. Loosen locking nut at eyebolt. Turn rod to adjust for length and reinsert into cam. Tighten locking nut and reinstall retaining ring. (See Fig. 7 on page 4)
10. Examine breaker operating bail to ensure it nests snugly against the eyebolts in which it is mounted. If not, spread the sides sufficiently to make a snug fit.
11. Check operation by switching breaker "ON" and "OFF", and by tripping and resetting breaker. Adjust operating handle stops, if necessary. The operating handle should hit the stop to prevent undue stress on the circuit breaker handle.

NOTE: When checking for RESET function, be sure the trip trigger of the breaker has returned to its original position.

WARNING

- EPC Series enclosures must be securely attached into a permanently grounded conduit system in accordance with Article 250 of the National Electrical Code.

- Be sure the system is properly grounded in accordance with the National Electrical Code. Inadequate grounding can result in electrocution.

WARNING

- Be sure that all receptacles that will accept interchangeable plugs, on the same premises, are wired to the same voltage, frequency and type of current (AC or DC). This requirement is in accordance with paragraph 210-7F of the National Electrical Code.

NOTE: The receptacles on the EPC enclosures are polarized so that mating plugs can enter the receptacle only one way. Also the pigtail leads on the receptacles and the contact silos in the plug insulator are identified by corresponding numbers. This assures proper polarity or phase rotation of conductors through receptacle and plug.

- Connect receptacle phase leads to breaker and ground lead to the ground conductor plug. Tighten breaker connections to recommended torque marked on circuit breaker. Refer to Table I and Figure 2, below.

WARNING

- For each system the same phase wire must be attached to the same numbered contact on all plugs and receptacles in that system. This will assure correct system polarity and reduce the possibility of equipment damage and/or personal injury due to misphasing or electrical shorts. ALWAYS TEST BEFORE ENERGIZING.

Table I

Receptacle Style	Receptacle and Plug Contact Identification by Number	Circuit Breaker Line Connections
3-wire 4-pole	Contact #2	L2
	Contact #3	L1
	Contact #1	L3
	GR (grounding contact)	Ground

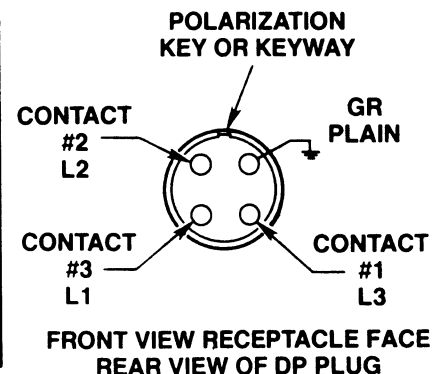
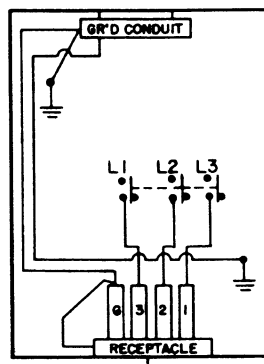

Figure 2
3-wire, 4-pole, Style 2 Contact Identification

INSTRUCTIONS FOR REPLACEMENT OF RECEPTACLE PARTS

1. Replacement of EPC-K35 (includes interlock rod, bushing, spring, hardware, and Loctite® Removable Threadlocker 290).

- Remove receptacle assembly following "INSTRUCTIONS FOR REPLACEMENT OF EPC602-2042R".
- Remove interlock rod and spring from receptacle housing by wrenching the tapered bushing counterclockwise. Bushing threads have been treated with a thread locker (removable), and will present a slight resistance to removal.

CAUTION

- Do not damage or scratch ground joint surfaces.

- Lubricate EPC-K35 KIT, interlock rod with Crouse-Hinds STL lubricant. DO NOT GET LUBRICANT ON BUSHING THREADS.
- Slide new washer and spring in new interlock rod to snap ring.

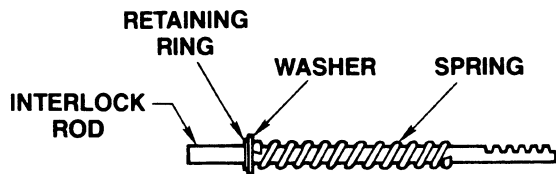

Figure 3

- Place new interlock rod with spring in receptacle.

CAUTION

- Alignment of rod rack teeth and pinion is required to fully insert rod. Do not force rod.

- Slide bushing over interlock rod, thread into receptacle housing.
- Adjust interlock rod length by rotating bushing. Set interlock rod length to face of receptacle. See illustration:

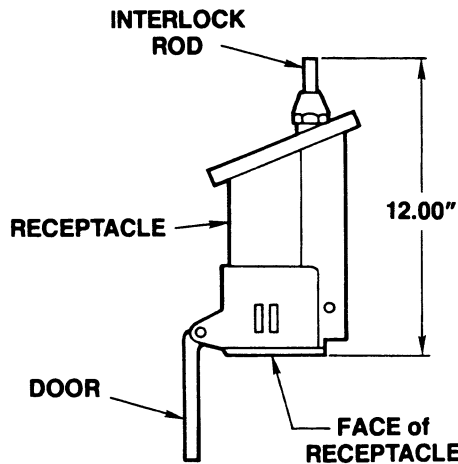

Figure 4

- Final adjustment, if required, is made by inserting plug. Plug should easily be fully inserted to plug flange surface with no resistance due to rack and pinion teeth interfacing. If interference condition exists, remove plug, rotate bushing clockwise 1/8 turn max. Repeat test inserting plug.

- Apply two drops Loctite Removable Threadlocker 290 between bushing and receptacle housing thread.

CAUTION

- CAUTION DO NOT allow Loctite to enter joint between interlocking rod and bushing, or on ground flange of receptacle.

- Replace receptacle assembly in enclosure following "INSTRUCTIONS FOR REPLACEMENT OF EPC602-2042R".

2. Replacement of EPC-K36 pinion and hardware.

(If pinion requires replacement, it is recommended the interlock rod and spring (EPC-K35) also be replaced.)

WARNING

- Electrical power supply to breaker must be OFF before and during installation and maintenance.

- Refer to Replacement of EPC-K35 (interlock rod, bushing, spring, etc.) for removal of rod.
- Remove spiral pin holding pinion, with a drift pin and hammer.

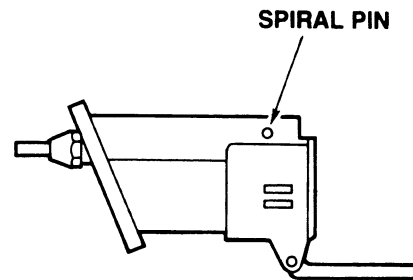

Figure 5

- Remove pinion and 2 spacers from inside receptacle housing; discard parts.
- If interlock rod has not been removed, inspect rod for binding and for damaged teeth. Replace if required. See "INSTRUCTIONS FOR REPLACEMENT OF EPC-K35 ASSEMBLY".
- Lubricate replacement pinion and spacers with Crouse-Hinds STL lubricant.
- Replace pinion and 2 spacers inside receptacle and secure with new spiral pin.

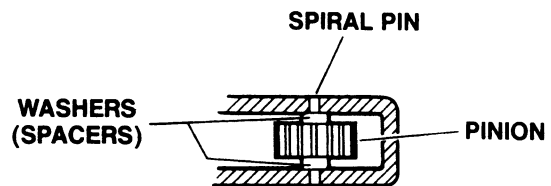

Figure 6

INSTRUCTIONS FOR REPLACEMENT OF ENCLOSURE PARTS

1. Replacement of EPC-K30, operating handle assembly (includes handle, shaft, bushing, cam and hardware).

WARNING

- Electrical power supply to breaker must be OFF before and during installation and maintenance.

- Insert plug and switch breaker to "ON" position.
- Remove large cover from top end of EPC enclosure.
- Disconnect bail operating rod from cam by removing retaining ring from end of rod. Set aside.
- Remove cam inside enclosure by wrenching off 1/4-20 bolt securing cam to shaft.
- Remove breaker operating handle (exterior) by wrenching off 5/16-18 bolt securing handle to shaft.
- Remove shaft from bushing, rotate counterclockwise.
- To remove bushing, bend back lock tab on indicating plate, rotate bushing counterclockwise.
- Secure indicating plate with replacement bushing. Bend up one lock tab on indicating plate across bushing hex flat.
- Replace shaft, lubricate with STL lubricant. Preliminary adjustment, set outside end of shaft approximately 11/16" from top of bushing.
- Reconnect circuit breaker operating arm to cam. Secure with retaining ring.
- Replace cam on end of shaft (cast in part number on cam faces shaft). Secure with 1/4-20 bolt.
- Refer to INSTRUCTIONS FOR CAM ADJUSTMENT on page 2.

DO NOT ADJUST INTERLOCK ROD

- Mechanically check that all parts are properly assembled, and operating mechanisms move freely.

CAUTION

- (POWER OFF) Plug must be fully seated in receptacle to actuate interlock before operating handle will move.
DO NOT FORCE breaker operating handle to "ON" position. Such action will damage mechanism and prevent proper operation. When plug is fully inserted, breaker operating handle should move freely to the "ON" position.

- Replace top cover; thread cover into body until fully seated.
- Turn operating handle to "OFF" position, disengage plug from receptacle.

2. Replacement of EPC-K33 (bail operating rod and retaining ring)

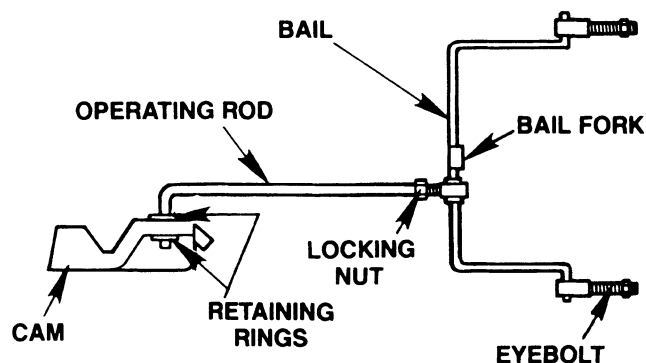

Figure 7

- Remove retaining ring on end of bail operating rod, remove from cam.
- Loosen locking nut at eyebolt on bail assembly. Remove bail operating rod by unthreading from eyebolt.
- Install new bail operating rod to bail eyebolt.
- Turn rod to adjust for length. Insert end of bail operating rod in cam and reinstall retaining ring.
- Tighten locking nut.

3. Replacement of EPC-K34 (bail assembly with hex nut and lock washer)

- Remove retaining ring from bail operating rod.
- Remove bail by pressing side of bail towards center and off eyebolts. Disconnect bail from bail operating rod.
- Position new bail fork over breaker operating handle. Replace bail in eyebolts.

To adjust bail height, remove bail and adjust the two bail eyebolts on the circuit breaker frame. Replace bail.

NOTE: Be sure bail is positively engaged in eyebolts; spread bail legs slightly if necessary to insure positive engagement.

- Thread operating rod on bail assembly. Turn rod to adjust for proper alignment between bail and cam; and insert in cam. Tighten locking nut. Reinstall retaining clip.

All statements, technical information and recommendations contained herein are based on information and tests we believe to be reliable. The accuracy or completeness thereof are not guaranteed. In accordance with Crouse-Hinds "Terms and Conditions of Sale", and since conditions of use are outside our control, the purchaser should determine the suitability of the product for his intended use and assumes all risk and liability whatsoever in connection therewith.



**CROUSE-HINDS
ELECTRICAL
CONSTRUCTION
MATERIALS**

Division of Cooper Industries, Inc. • Syracuse, New York 13221 • U.S.A.

IF1239