

2P Ark•Gard® ENR Series

Premier and Value Series

Ark•Gard® Premier Series:

- The premier line of ENR Receptacles (M4) come equipped with exclusive features that increase the life of the product, reduce maintenance costs, and eliminate the need to purchase costly replacement parts. There is no other product offering on the market today that comes equipped with time-saving saddle clamp terminals or the added safety of a lockout/tagout hole. The premier ENR Receptacle Series is the ideal solution for applications where increased safety and reliability are critical.

Ark•Gard® Value Series:

- The value line of ENR Receptacles is the ideal solution for rugged and industrial NEMA configured applications up to 20 amperes. Like the premier line, this product comes equipped with built-in safety features that reject standard NEMA configuration plugs that could cause an arc in hazardous areas.

FEATURES AND BENEFITS - Premier Solution (M4)

Gasketed Screw Cap Cover Design:

- Offers superior protection from harsh environments for increased product life
- Eliminates the need to purchase a separate environmental cover for added protection

Complies with OSHA lockout/tagout requirements:

- Lockout/tagout hole in cover gives users the ability to lock the cover closed while not-in-use

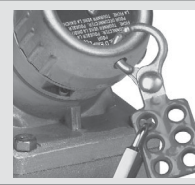

Spring-Loaded Sliding Key Offers Increased Safety:

- Rejects standard NEMA/EEMAC configuration plugs that could cause an arc in a hazardous area.
- Also prevents the receptacle faceplate from being rotated until the ENP plug is fully inserted.

Protected Hinge:

- Cap design provides 360° of protection around cover hinge to reduce damage from dirt and corrosion

Saddle Clamp Terminals:

- Reduce installation and maintenance costs – easy to wire, time-saving terminals

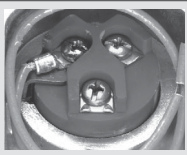

Integral Bushings:

- Taper tapped hubs protect wire installation during wire-pulling

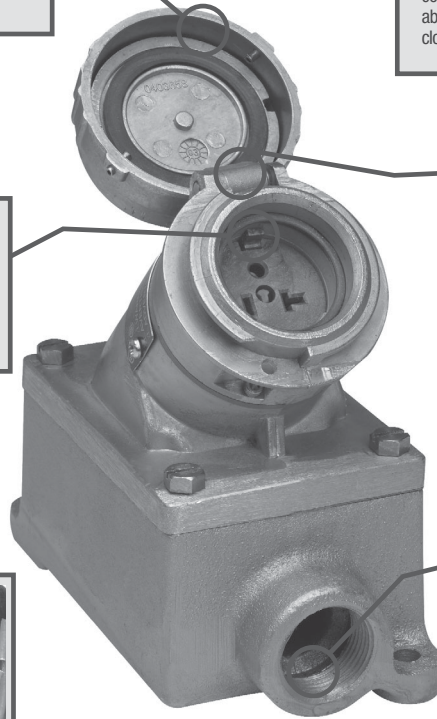

FEATURES AND BENEFITS - Traditional Value Solution

- To make connection, simply insert the ENP plug and rotate to close the circuit
- Built-in features cause the ENP plug to become locked in the receptacle and cannot be accidentally disengaged while in use

- Top hinged cover design with 45° downward angle provides protection in damp, wet and dirty locations

- Molded-in contact design provides for superior interior contact reliability
- Incorporates three spring-loaded slide keys that prevent the receptacle face plate from being rotated until the ENP plug is fully inserted into the receptacle.

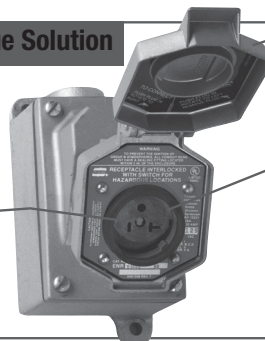

ENR Premier Series Dead Front Interlocked Circuit Breaking Receptacles

Cl. I, Div. 1 & 2, Groups B*, C, D
Cl. II, Div. 1 & 2, Groups F, G
Cl. III
NEMA 3, 3R, 7BCD, 9FG, 12

Explosionproof
Dust-Ignitionproof
Raintight
Wet Locations

2P

ENP Plugs

Applications:

Ark•Gard® products are used:

- In applications that require additional environmental protection
- With portable or fixed electrical equipment such as motor generator units, welders, pumps, compressors, heating and cooling units, cellular relay stations, conveyors, lighting systems, and similar equipment
- In areas made hazardous by the presence of flammable vapors and gases or combustible dusts
- When power requirements do not exceed 20 amperes

Certifications and Compliances:

- NEC:
 - Class I, Division 1, Groups B*, C, D
 - Class II, Groups F, G
 - Class III
 - NEMA 3, 3R
- CEC‡:
 - Class I, Division 1, Groups B*, C, D
 - Class II, Group G
 - Class III
 - NEMA 3, 3R

Standard Materials:

- Receptacle housing, spring door and plug body – die cast copper-free aluminum
- Interiors: receptacle – *Krydon*® fiberglass-reinforced polyester material; plug – nylon 100
- Contacts: receptacle blade – brass; receptacle switch – silver; plug – brass
- Receptacle cover hinge pin and spring – stainless steel
- Receptacle gasket – neoprene
- Plug bushing – neoprene
- Back boxes – copper-free aluminum

Standard Finishes:

- Copper-free aluminum – aluminum acrylic paint
- Brass – natural

Options:

Description

Corro-free™ epoxy powder finish for added corrosion resistance

Suffix

S752

Electrical Rating Ranges:

- Receptacles:
 - 15 amperes; 125 VAC and 250 VAC, 50–400 hertz
 - 20 amperes; 125 VAC and 250 VAC, 50–400 hertz
- Plugs:
 - 15 amperes; 125 VAC and 250 VAC, 50–400 hertz
 - 20 amperes; 125 VAC and 250 VAC, 50–400 hertz

Grounding:

- NEC Article 501 and CEC Section 18 requires that metal frames or exposed non-current-carrying metal parts of portable devices used in hazardous locations be grounded through an extra conductor in the portable cord. ENR Receptacles and ENP Plugs are provided with an extra grounding pole.

Dimensions In Inches:

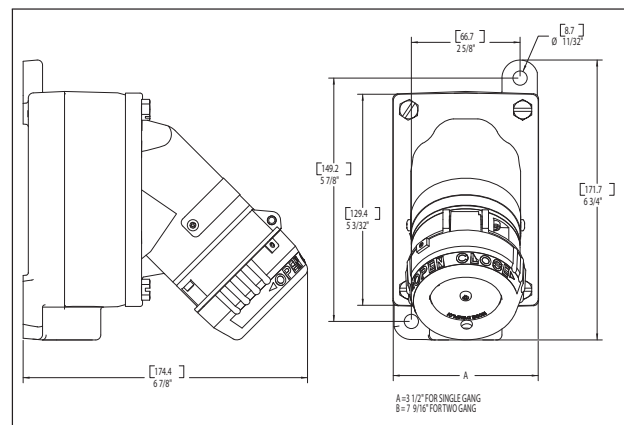

Type

Single Gang
Double Gang

Dimension A

3 1/2"
7 9/16"

*Single gang assemblies purchased with an EFS back box are suitable for Class I, Group B.
‡15A units are CSA Listed only.

ENR Premier Series Dead Front Interlocked Circuit Breaking Receptacles ENP Plugs

Cl. I, Div. 1 & 2, Groups B*, C, D
Cl. II, Div. 1 & 2, Groups F, G
Cl. III
NEMA 3, 3R, 7BCD, 9FG, 12

Explosionproof
Dust-Ignitionproof
Raintight
Wet Locations

Ordering Information:

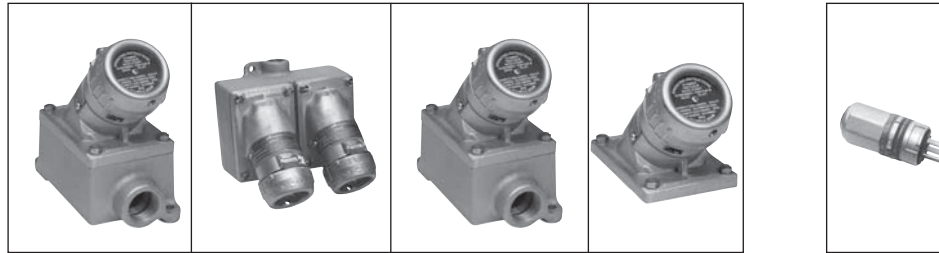

15 A	15 A Receptacle Rating	Description	Hub Size	Single Gang* Receptacle Assembly Cat. #	Two Gang** Receptacle Assembly Cat. #	Group B Listed‡ Single Gang Assembly Cat. #	Receptacle§ Unit Only Cat. #	NEMA Config.	15 A Plug†† Cat. #	NEMA Config.
SP	15 Amp 125 Volt	Dead End	1/2"	ENR11151 M4	ENR12151 M4	ENRB11151 M4	ENR5151 M4		ENP5151	
			3/4"	ENR21151 M4	ENR22151 M4	ENRB21151 M4				
			1"	ENR31151 M4	ENR32151 M4	ENRB31151 M4				
		Through Feed	1/2"	ENRC11151 M4	ENRC12151 M4	ENRCB11151 M4				
3/4"	ENRC21151 M4		ENRC22151 M4	ENRCB21151 M4						
1"	ENRC31151 M4		ENRC32151 M4	ENRCB31151 M4						
UL	15 Amp 250 Volt	Dead End	1/2"	ENR11152 M4	ENR12152 M4	ENRB11152 M4	ENR6152 M4		ENP6152	
			3/4"	ENR21152 M4	ENR22152 M4	ENRB21152 M4				
			1"	ENR31152 M4	ENR32152 M4	ENRB31152 M4				
		Through Feed	1/2"	ENRC11152 M4	ENRC12152 M4	ENRCB11152 M4				
3/4"	ENRC21152 M4		ENRC22152 M4	ENRCB21152 M4						
1"	ENRC31152 M4		ENRC32152 M4	ENRCB31152 M4						
UL	20 Amp 125 Volt	Dead End	1/2"	ENR11201 M4	ENR12201 M4	ENRB11201 M4	ENR5201 M4		ENP5201	
			3/4"	ENR21201 M4	ENR22201 M4	ENRB21201 M4				
			1"	ENR31201 M4	ENR32201 M4	ENRB31201 M4				
		Through Feed	1/2"	ENRC11201 M4	ENRC12201 M4	ENRCB11201 M4				
3/4"	ENRC21201 M4		ENRC22201 M4	ENRCB21201 M4						
1"	ENRC31201 M4		ENRC32201 M4	ENRCB31201 M4						
SP	20 Amp 250 Volt	Dead End	1/2"	ENR11202 M4	ENR12202 M4	ENRB11202 M4	ENR6202 M4		ENP6202	
			3/4"	ENR21202 M4	ENR22202 M4	ENRB21202 M4				
			1"	ENR31202 M4	ENR32202 M4	ENRB31202 M4				
		Through Feed	1/2"	ENRC11202 M4	ENRC12202 M4	ENRCB11202 M4				
3/4"	ENRC21202 M4		ENRC22202 M4	ENRCB21202 M4						
1"	ENRC31202 M4		ENRC32202 M4	ENRCB31202 M4						

*Single gang assemblies purchased with an EDS back box are suitable for Class I, Groups C, D only. For self-certified Class I, Group B rating, add the suffix "GB" to the catalog number (i.e. ENR21201 M4 GB).

**Dual gang assemblies purchased with an EDS back box are suitable for Class I, Groups C, D only. For self-certified Class I, Group B rating, add the suffix "GB" to the catalog number (i.e. ENR22201 M4 GB).

‡Single gang assemblies purchased with an EFS back box are suitable for Class I, Group B.

§Receptacle units alone (i.e. ENR5201) are not suitable for Class I, Group B.

††ENP plugs use #12 or #14 AWG type S, SO, ST or STO cord with range of .540 to .635 inches diameter.

Note: Assemblies standard with copper-free aluminum EDS, EDSC, EFS, EFSC back boxes.