

Board-to-Board Configurable Connectors

MIL-C-28754



SOURIAU
Connection Technologies

8602 NAFI



Applications

Military airborne computer

Standards

According to MIL-C 28754 and NAVORD WS 6157



Description

- NAFI board-mounted connectors are used as interface between daughter-boards and back planes or between two adjacent daughter-boards.

- The connector support is of light alloy. It is drilled to a 2.54 x 2.54 mm (.100 x .100) matrix accommodating contacts housed in modular insulators with one, two or four contacts. On assembly, the blocks form inter-connections of different length and width.

- The daughter board is generally associated with a male header. The male header is an aluminum alloy extrusion holding blade contacts for solder angle and straight spill termination.

- The system is highly flexible. Aluminum alloy is robust, light, simple and may be machined accurately.

- The association of blade and tuning fork contacts is a simple design, highly efficient under severe vibration.

- Contact numbers : from 10 to 300.

Characteristics

Mechanical

- Contact insertion and extraction forces per contact pair :
 - mating ≤ 0.45 N average
 - unmating > 0.25 N
- Block retention in support ≥ 35 N
- Contact retention in insulator ≥ 35 N
- Contact endurance : mating/unmating cycles ≥ 500

Electrical

- Signal contacts :
 - maximum current rating per contact 3 A
 - DWV 1000 V
 - insulation resistance ≥ 5000 M Ω
 - contact resistance $\leq 6,7$ m Ω
- Coaxial contacts for cable impedance 50 Ω , 75 Ω , 95 Ω
- Power contacts current rating 10 A, 15 A, 20 A
- Fibre optic contact attenuation at 850 nm = 1,5 dB typical

Physical

As per MIL-C 28754

- Tests as per MIL-C 1344
 - damp heat method 1002
 - thermal shock method 1003
 - salt spray method 1001
 - physical shock method 2004
 - vibration method 2005
- Working temperature :
 - polyimide insulator series MIL-C 28754 - 55°C + 105°C

Materials and finishes

components	materials	finishes
Modular insulators	<ul style="list-style-type: none"> • polyimide 6 x 6 self extinguishing natural colour 	
Male contacts	brass	<ul style="list-style-type: none"> • active area : gold over nickel
Female contacts	copper alloy	<ul style="list-style-type: none"> • termination area : standard tinlead OR pure tin (RoHS) over nickel
Extruded supports and back planes	aluminum alloy	<ul style="list-style-type: none"> • Surtec (RoHS/REACH) • optional black anodized
Polarizing keys <ul style="list-style-type: none"> • non removable male • removable male • non removable female • removable female 	stainless steel nickel copper aluminum alloy nickel copper	

8602 NAFI



Ordering information

basic series		8602 - 100 - 22 - 13 - 2 - 10				26 -	000
number of contacts							
connector type		2 rows	3 rows	4 rows			
male		22	24	26			
female	with stand off	11	13	15			
	without stand off	31	33	35			
contact termination		13 - angle spill Pwb (.063) (male contacts only) 14 - straight spill Pwb (.063) to (.126) 15 - 2 wire wraps } female contacts only 25 - 3 wire wraps 27 - flex cable spill XX - others please consult us					
contact plating		1 - lead-free tin / gold 0.4µm 2 - lead-free tin / gold 1.25µm 8 - tin lead / gold (according to MIL-C 28754) - only for female contacts					
polarization		- fixed key guides Coding see table below		End A - key shape End B - key shape			
		Coding example 10 - End A : male D shape key orientation 26 - End B : male V shape key orientation 4040 - removable key guides Example : 8602 - 100 - 22 - 13 - 5 - 4040 - 000					
suffix		000 - standard 031 - DIN 41612 interchangeable connector - others please consult us 008 - with fixing version					

MIL key guides coding

shape	male-orientation								★	★	female-orientation							
D																		
V																		
O																		

★ 18 - 28 - 38 are corresponding to key guides delivered separately

8602 NAFI



Female connector wire wrap or straight spill terminations

without fixing version (standard) 000 suffix

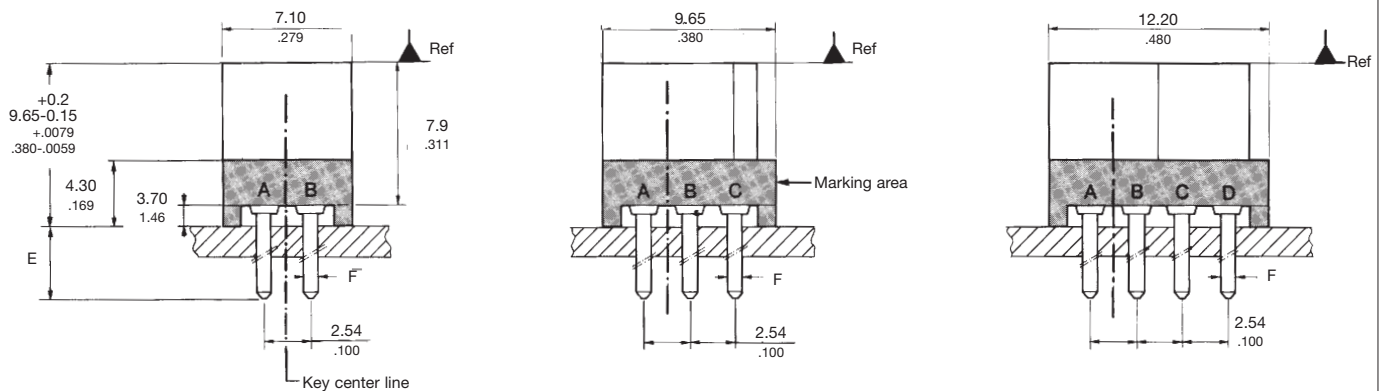

▲ Mating datum plane

* Please, consult us

Note : A, B, C, D, row marking at the request

straight spills			wire wraps		
PWB thickness	E	FØ	nb wraps	E	FØ
1.6 (.062)	*	*	1	*	*
2.4 (.095)	4.45 (.175)	0.43 (.017)	2	12.85 (.505)	0.87 (.034)
3.2 (.126)	4.45 (.175)	0.43 (.017)	3	16.05 (.632)	0.87 (.034)
-	-	-	4	*	*

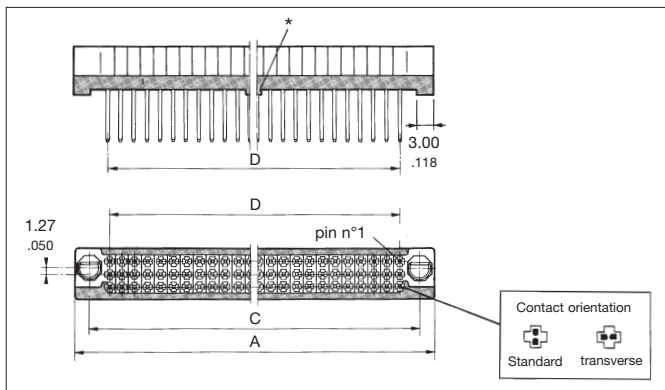

formula	ex : 100 contacts / 2 rows
$D = \left(\frac{n}{r} - 1\right) \times 2,54$	$\left(\frac{100}{2} - 1\right) \times 2,54 = 124,46$
$D = \left(\frac{n}{r} - 1\right) \times (.100)$	$\left(\frac{100}{2} - 1\right) \times (.100) = (4.900)$
$A = D + 13,54$	$124,46 + 13,54 = 138,00$
$A = D + (.533)$	$(4.900) + (.533) = (5.433)$
$C = D + 7,62$	$124,46 + 7,62 = 132,06$
$C = D + (.300)$	$(4.900) + (.300) = (5.200)$

n : number of contacts
r : number of rows

* Center mounting stand off is used only in contact arrangement over 50 per row.

with fixing version - 008 specification

Dimensions : see male connector straight spill termination

8602 NAFI



Female connector angled spill terminations for card extender

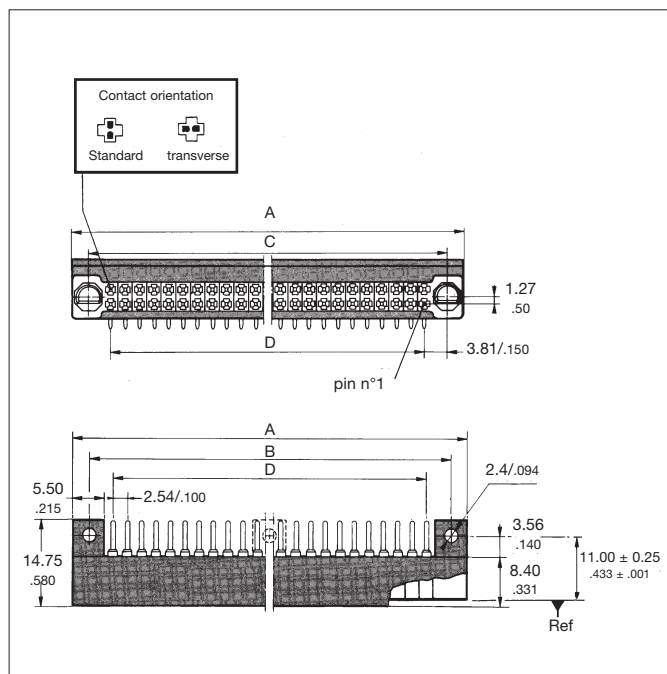
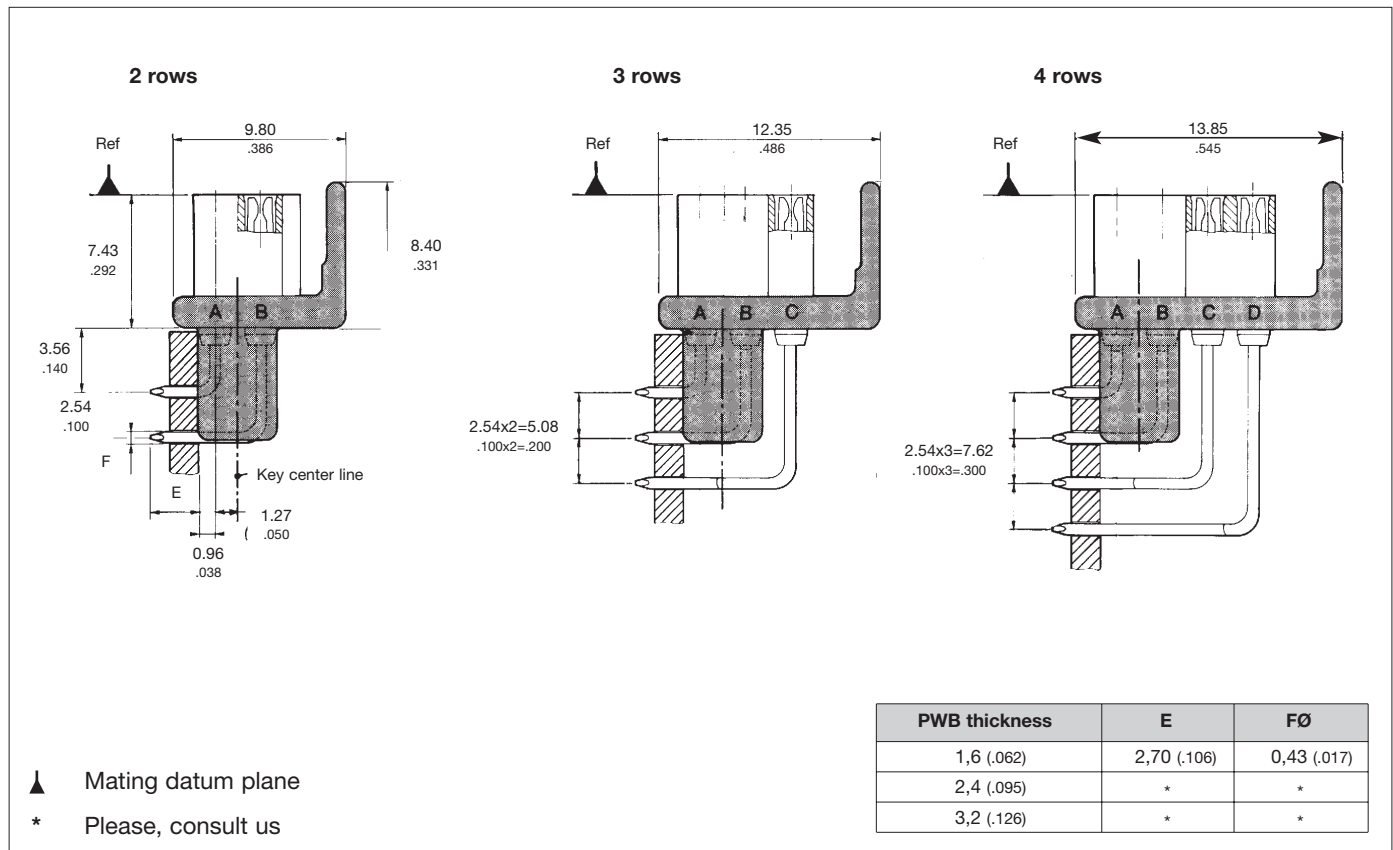

formula	ex : 100 contacts / 2 rows
$D = \left(\frac{n}{r} - 1\right) \times 2,54$	$\left(\frac{100}{2} - 1\right) \times 2,54 = 124,46$
$D = \left(\frac{n}{r} - 1\right) \times (.100)$	$\left(\frac{100}{2} - 1\right) \times (.100) = (4.900)$
$A = D + 15,24$	$124,46 + 15,24 = 139,70$
$A = D + (.600)$	$(4.900) + (.600) = (5.500)$
$C = D + 7,62$	$124,46 + 7,62 = 132,09$
$C = D + (.300)$	$(4.900) + (.300) = (5.200)$
$B = D + 10,16$	$124,46 + 10,16 = 134,62$
$B = D + (.400)$	$(4.900) + (.400) = (5.300)$

n : number of contacts
 r : number of rows

8602 NAFI



Male connector angle spill terminations

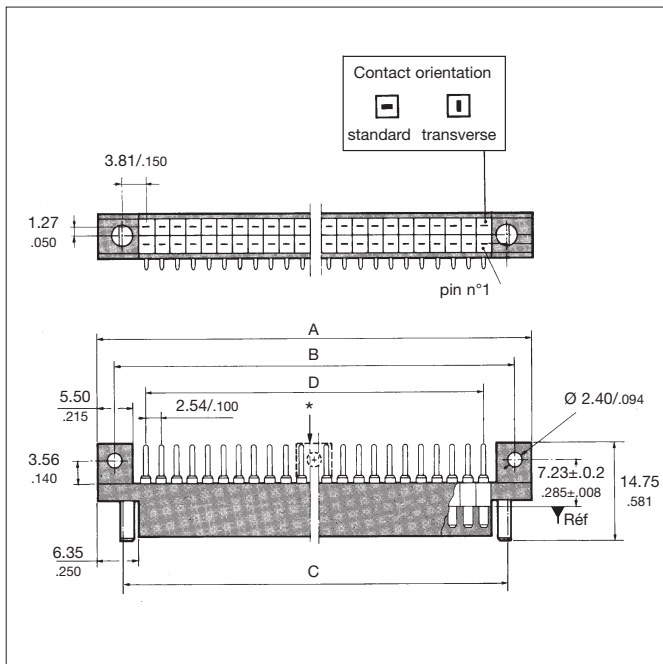
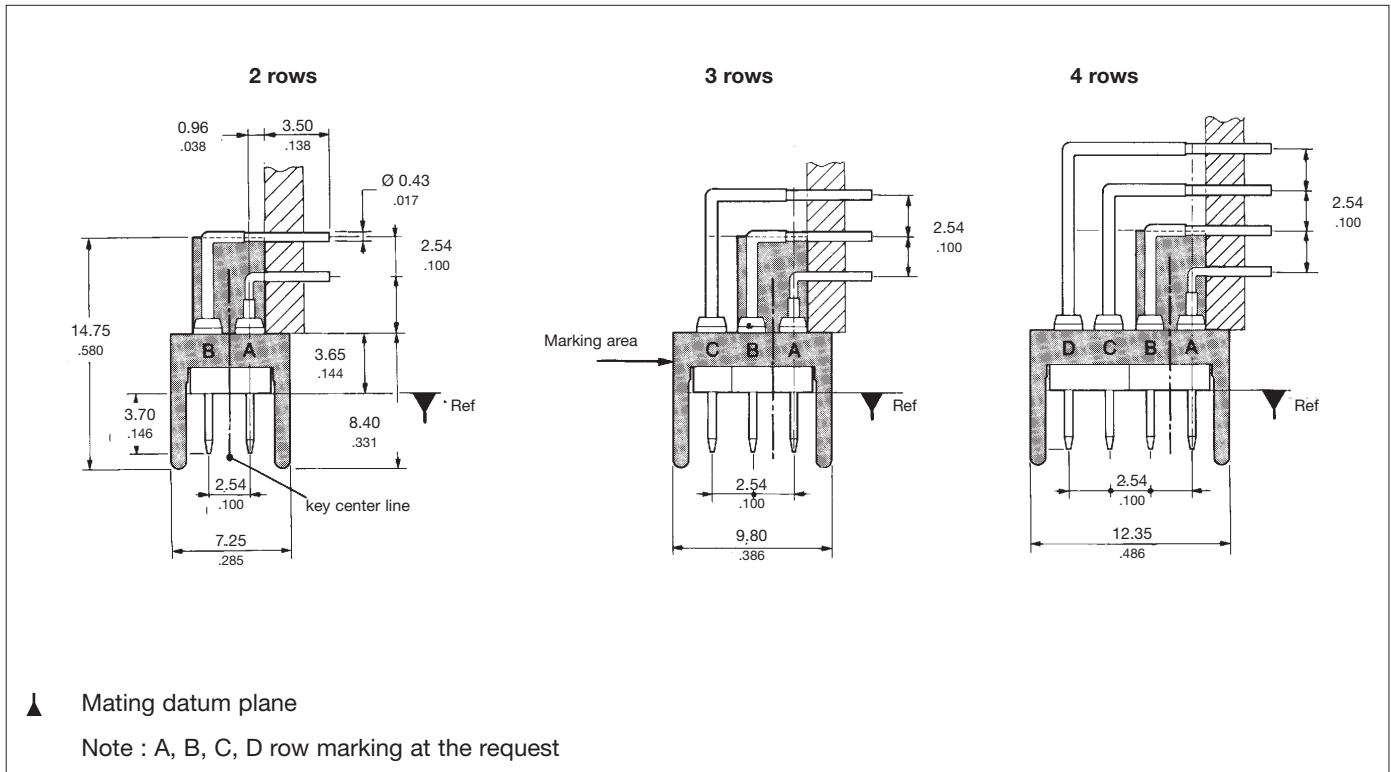

formula	ex : 100 contacts / 2 rows
$D = \left(\frac{n}{r} - 1\right) \times 2,54$	$\left(\frac{100}{2} - 1\right) \times 2,54 = 124,46$
$D = \left(\frac{n}{r} - 1\right) \times (.100)$	$\left(\frac{100}{2} - 1\right) \times (.100) = (4.900)$
$A = D + 15,24$	$124,46 + 15,24 = 139,70$
$A = D + (.600)$	$(4.900) + (.600) = (5.500)$
$C = D + 7,62$	$124,46 + 7,62 = 132,09$
$C = D + (.300)$	$(4.900) + (.300) = (5.200)$
$B = D + 10,16$	$124,46 + 10,16 = 134,62$
$B = D + (.400)$	$(4.900) + (.400) = (5.300)$

n : number of contacts
r : number of rows

* Center fixing recommended from 50 contacts per row.

8602 NAFI



Male connector straight spill terminations

without fixing version (standard) - 000 suffix

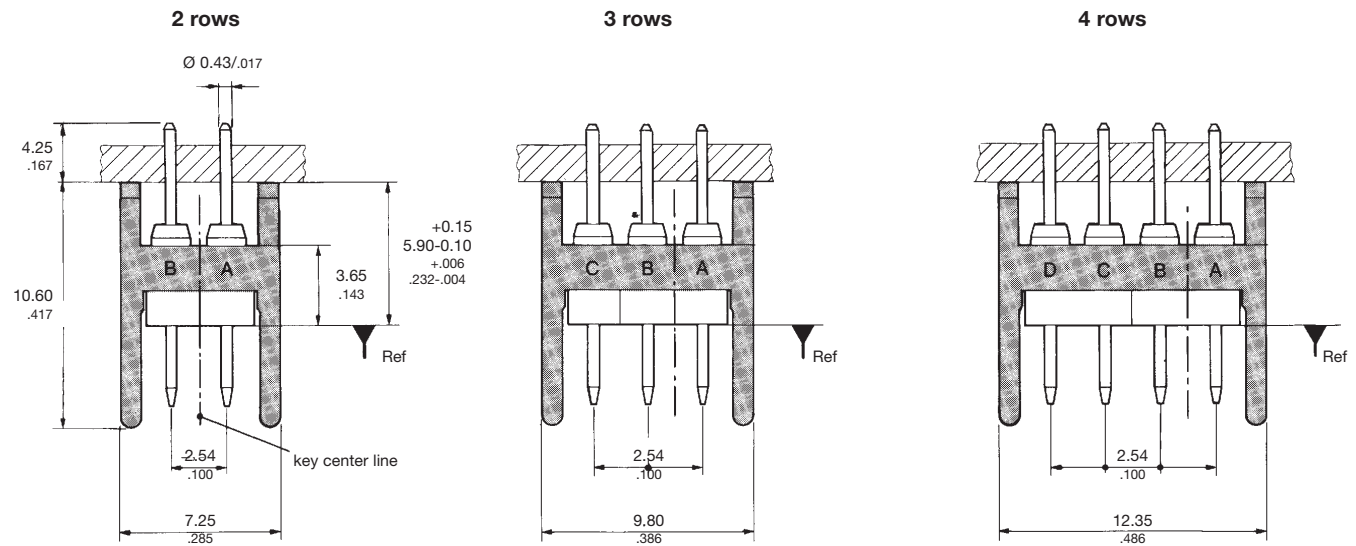

▲ Mating datum plane

with fixing version - 008 specification

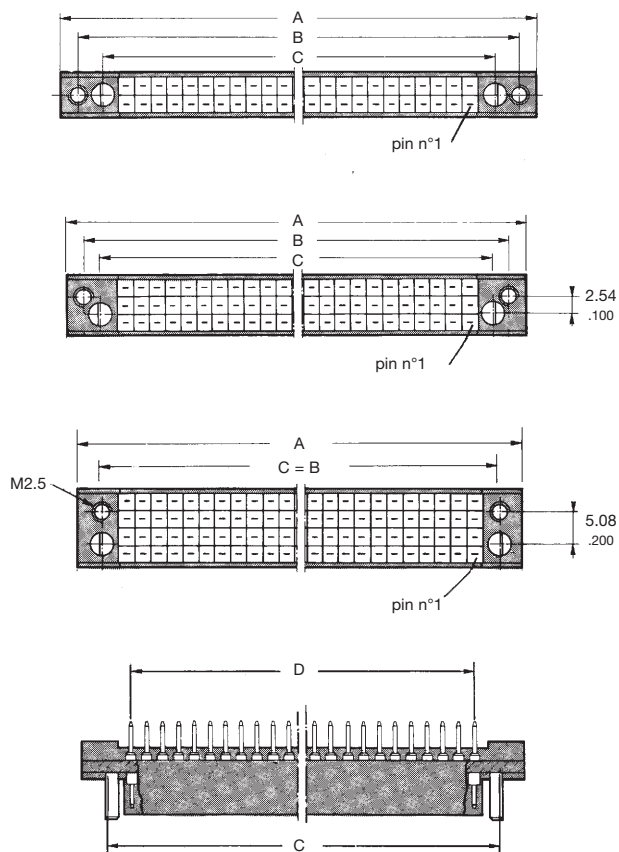

male modules details

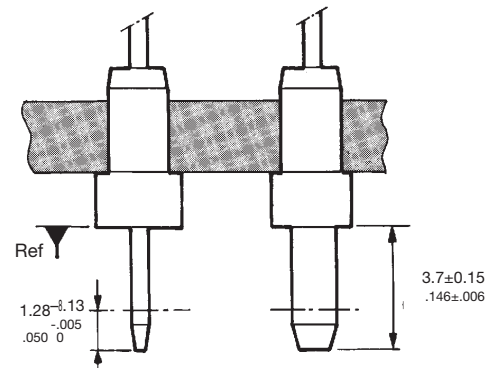

formula

$$D = \left(\frac{n}{r} - 1\right) \times 2,54$$

$$D = \left(\frac{n}{r} - 1\right) \times (.100)$$

n : number of contacts
r : number of rows

dimension	2 rows	3 rows	4 rows
A	D + 20.32	D + 17.78	D + 15.24
A	D + (.800)	D + (.700)	D + (.600)
B	D + 15.24	D + 12.70	D + 7.62
B	D + (.600)	D + (.500)	D + (.300)
C	D + 7.62	D + 7.62	D + 7.62
C	D + (.300)	D + (.300)	D + (.300)

8602 NAFI



Key guides - non removable as per MIL-C 28754/24 and 39

shape	male	female
D		
V		
O		

Standard polarizing keys are integrated into part-number. They are supplied installed in the orientation selected by user. The polarizing keys may also be supplied separately (code 18, 28 or 38). Please, consult us for installation tool.

PWB pin layout

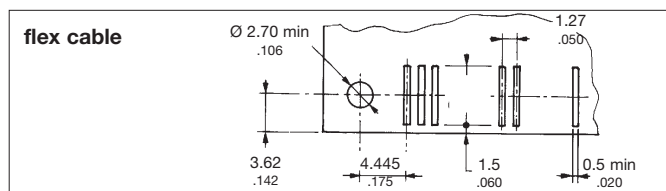
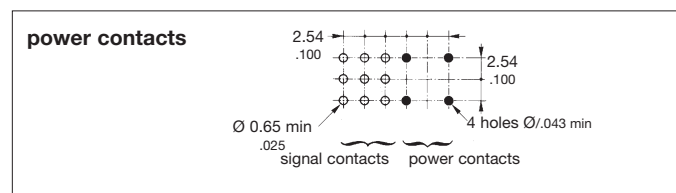
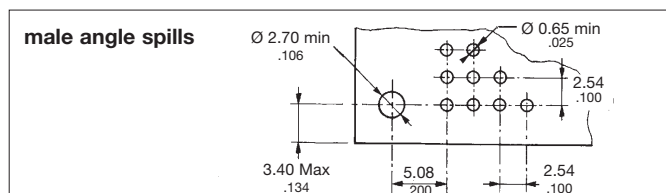
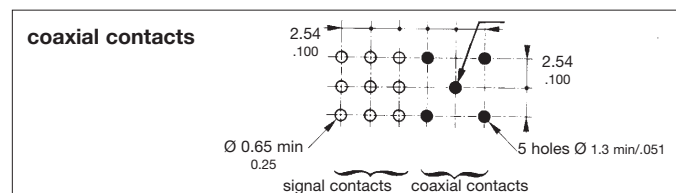
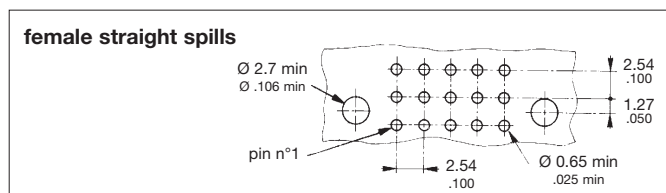

Specific versions available upon request

Hand tools

part number	Purpose	part number	Purpose
8602-01	contact insertion / removal W.W female contact, installed on extrusion	8602-04	Re-insertion Straight spill male contacts
8602-02	contact insertion / removal W.W female contact, installed on metal back-plane	8602-05	Installation of male polarizing keys D-shape code 18, supplied separately
8602-03	removal Male and female straight spill contacts	8602-06	Re-insertion Female contacts, all termination types.

8602 NAFI



DIN 41612 interchangeable 8602 contacts

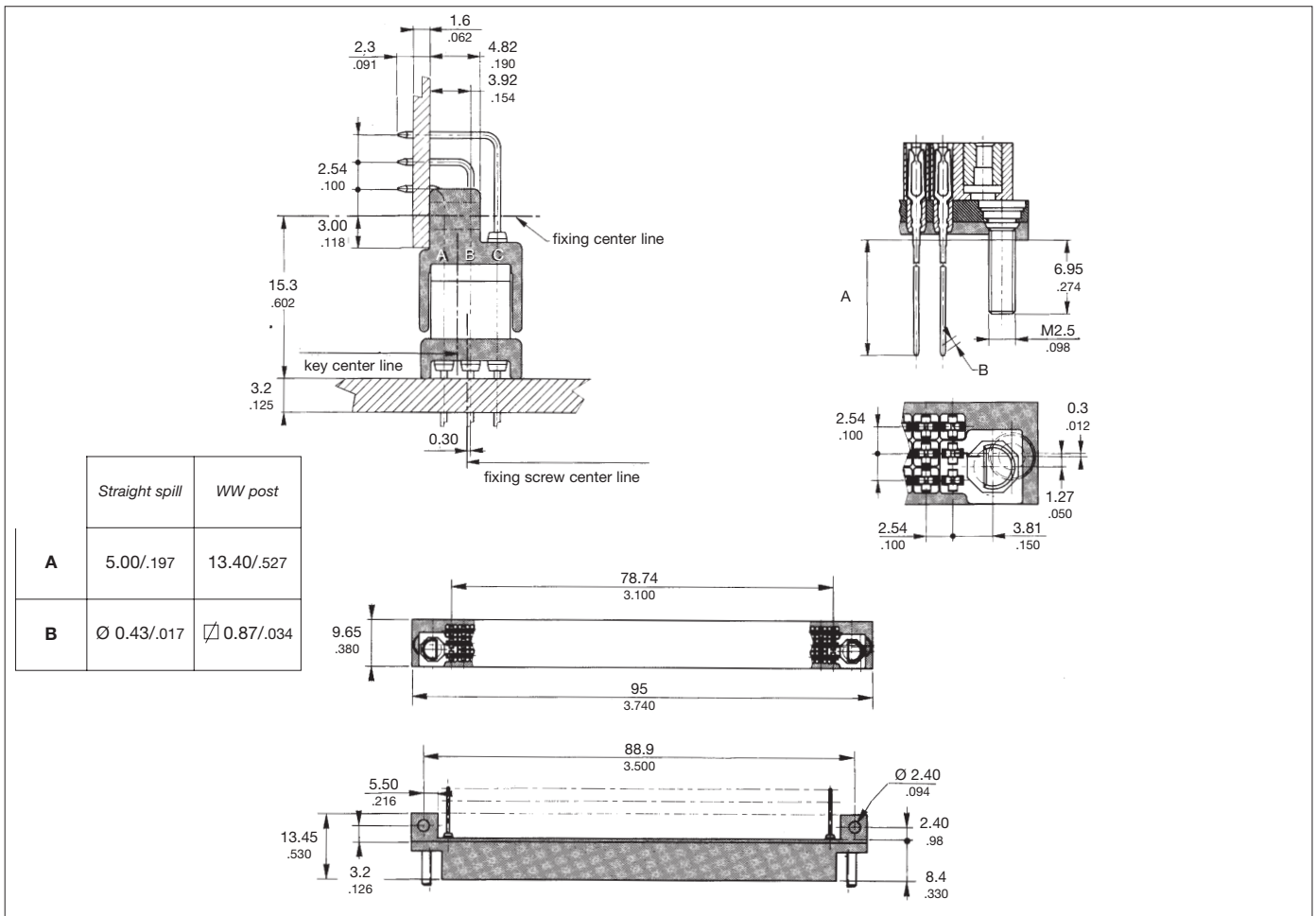

Special contacts

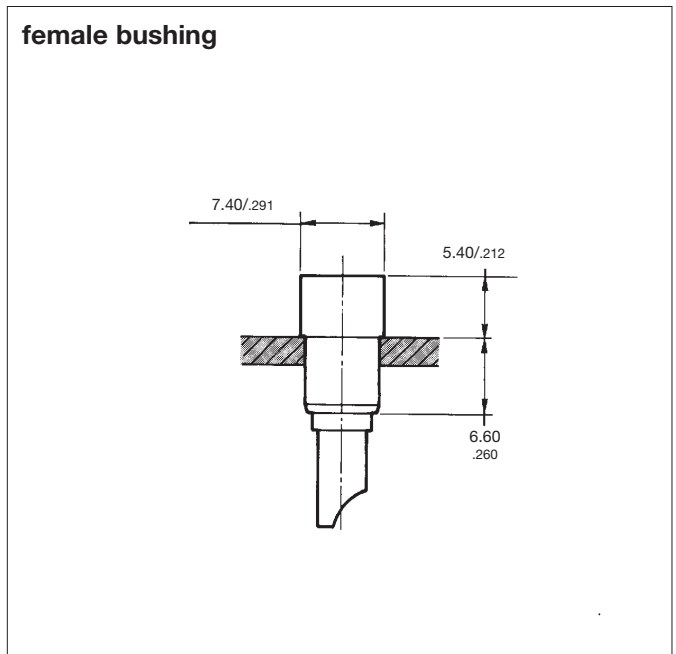
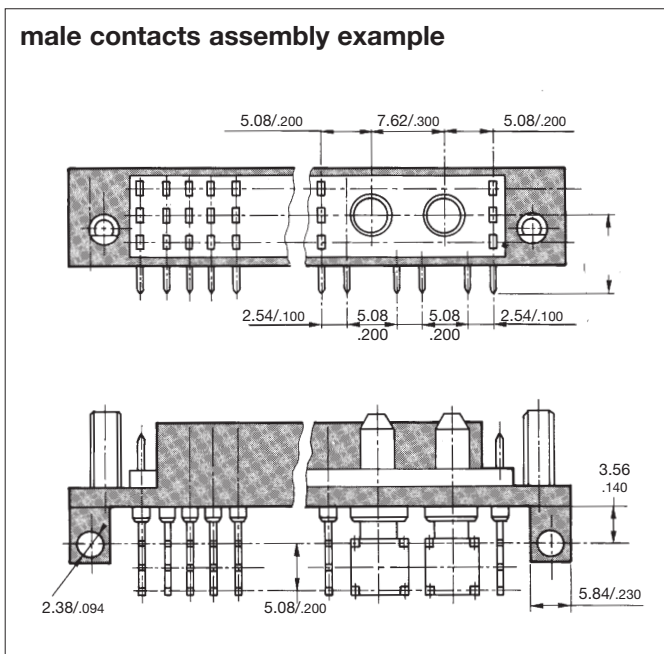

8602 NAFI



Coaxial or power contact connector part numbers

basic series	8602 - 100 - 22 - 13 - 5 - 10 26 - B 00											
number of signal contacts												
connectors type												
contact termination	see general ordering information page 404											
contact plating												
polarization												
number of coax or power cavities												
nbr of cavities	1	2	3	4	5	6	7	8	9	10	11	12
code	A	B	C	D	E	F	G	H	I	J	K	L
suffix												

Coaxial contacts to HE 507 and KMX specifications

male solder termination
part number : 8602-1010

part number : 8602-1012

female solder termination
part number : 8602-1011

removal tool : 8630-07A

Optical fiber contacts (DIN 41626)

part number : 8012P43D168

part number : 8012S43D168

For tight jacketed cable Ø 2.7 (.106) mm fibre 100/140
Please consult us for other cables and fibers

Power contacts to HE 507 and KMX specifications

male solder termination
part number : 8602-1009

part number : 8602-1001

female solder termination
part number : 8602-1008

current : 15 A AWG 14

removal tool : 8630-07a

Others : please, consult us

Reliable People, Reliable Solutions



Your local contact



Our contribution to environmental protection:
This catalog is printed on PEFC certified paper
Advancement of sustainable wood cultivation. www.pefc.org

www.souriau.com
technical.emear@souriau.com (Europe - Asia - Africa)
technical.americas@souriau.com (North America)

