

JDX SERIES



# SOURIAU

High Density Sealed Breakaway Connectors





### Presentation

The JDx Breakaway design, ensures a safe quick disconnect if cable becomes entangled. The addition of the JDx Hybrid mixed power and signal connector offers the ability to integrate 2 or 3 power contacts with 6 to 8 signal contacts in one connector housing.

### Contents

<b>Overview</b>			
Applications.....	6	Ordering Information .....	19
Features & Benefits .....	7	Dimensions.....	20-21
Range Overview .....	8-9	Contact Layouts.....	22-23
		Contact & Wire Information .....	24
<b>Mechanics</b>		<b>JDX Hybrid Breakaway Connectors</b>	
Shell Styles .....	12	Technical Information .....	28
Keying & Dust Caps .....	13	Ordering Information .....	29
Technical Characteristics.....	14-15	Dimensions.....	30-31
<b>JDX Standard Breakaway Connectors</b>		Contact Layouts / Contact & Wire Information	32
Technical Information .....	18	Derating Curves.....	33
		Existing Hybrid Part Numbers .....	34

# JDX SERIES

## JDX Breakaway Connectors

# Overview

■ Applications .....	06
■ Features & Benefits .....	07
■ Range Overview .....	08-09



## Typical Applications



Robotics



UAV



Military Communications

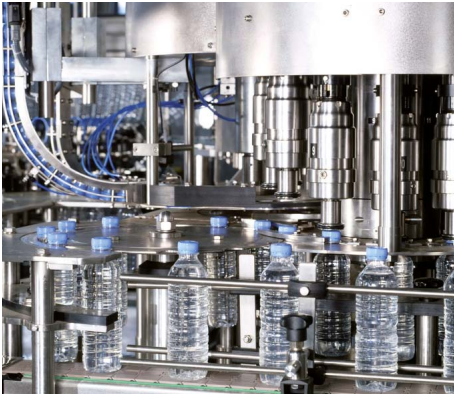

Industrial



Instrumentation

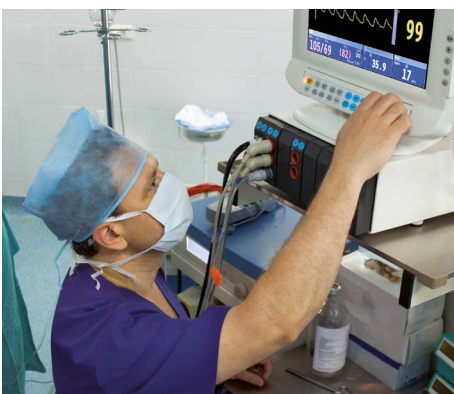

Medical Equipment

## Features & Benefits

- QUICK RELEASE** **Breakaway Design**  
Eliminates the need for a manually operated latching system. It disengages at specified pull force levels to ensure a safe quick disconnect if cable becomes entangled.
- WATER PROOF** **IP 68 Mated and Unmated**  
Water and dust protection, secure for outdoor and indoor applications.
- COMPACT** **Light & High Density**  
High contact density for small footprint, allows access in tight applications, space savings.
- HYBRID** **Mixed Power & Signal Contacts**  
Integrates power and signal contacts in one connector housing. Reduces system complexity and the subsequent consumption of valuable space and installation costs.
- RUGGED** **Robust**  
Withstand harshest environments.  
High vibration and temperature resistant

Receptacle Range

**JDX Shell Sizes**

See page 22 & 23 JDX Standard  
See page 32 JDX Hybrid

**JDX Cable Assembly**

Overmold option for IL Shell  
(In-Line receptacle only)

**JDX Contacts**

**JDX Receptacle Shell Styles**

See page 12 JDX Standard & Hybrid

**JDX Standard Breakaway**



Shell Sizes 0



Shell Sizes 1



Shell Sizes 2

**JDX Hybrid Breakaway**



Shell Sizes 2  
(for other sizes consult factory)



**Solder Contacts**

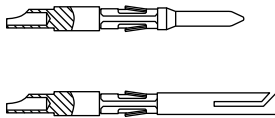

**Contacts for PCB**

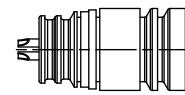
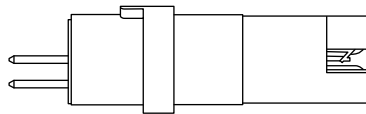

IL: In-Line Cable Receptacle

**Please note:**

IL In-Line Cable Receptacle is supplied as overmolded cable assembly or as stand along connector (strain relief boot not available for this product)

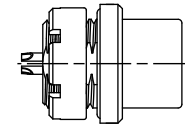

EP: Front Panel Mount

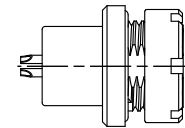

ER: Rear Panel Mount

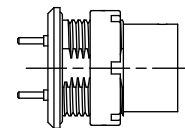

EZ: Rear Panel Mount PCB Capable Protruding Front (With Grounding Pins)

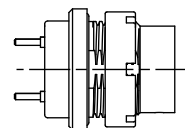

ED: Rear Panel Mount PCB Capable (With Grounding Pins)

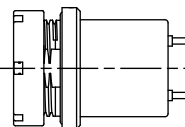

EE: Rear Panel Mount PCB Capable Protruding Back (With Grounding Pins)



Plug Range

**JDX Plug Shell Styles**

See page 12 JDX Standard & Hybrid

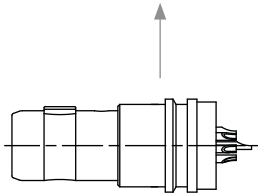

FD: Straight Cable Plug

**Please note:**

FD Straight Plug is supplied as overmolded cable assembly or as stand alone connector (strain relief boot not available for this product)

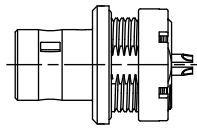

FA: Front Panel Mount Plug

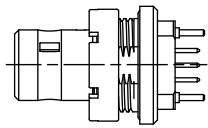

FB: Rear Panel Mount Plug (With Grounding Pins)

**JDX Contacts**

**Solder Contacts**

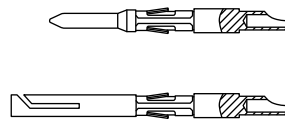

**Contacts for PCB**

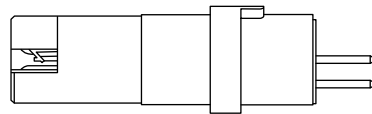

**JDX Cable Assembly**

Overmold option FD shell (Straight Plug only)



**JDX Shell Sizes**

See page 22 & 23 JDX Standard  
See page 32 JDX Hybrid

**JDX Standard Breakaway**



Shell Sizes 0



Shell Sizes 1



Shell Sizes 2

**JDX Hybrid Breakaway**



Shell Sizes 2  
(for other sizes consult factory)

# JDX SERIES

JDX Breakaway Connectors (Standard & Hybrid)

# Mechanics

■ Shell Styles .....	12
■ Keying & Dust Caps .....	13
■ Technical Characteristics .....	14-15

### Shell Styles

**Receptacles**

EZ: Rear Panel Mount PCB Capable  
Protruding Front (With Grounding Pins)

← Mounting Plane

ER: Rear Panel Mount

ED: Rear Panel Mount PCB Capable  
(With Grounding Pins)

EP: Front Panel Mount

EE: Rear Panel Mount PCB Capable  
Protruding Back (With Grounding Pins)

Mounting Plane →

IL: In-Line Cable Receptacle

**Please note:**  
IL In-Line Cable Receptacle is supplied as overmolded cable assembly or as stand alone connector (strain relief boot not available for this product)

**Plugs**

FD: Straight Cable Plug

**Please Note:**  
FD Straight Plug is supplied as overmolded cable assembly or as stand alone connector (strain relief boot not available for this product)

FA: Front Panel Mount Plug

FB: Rear Panel Mount Plug  
(With Grounding Pins)

Note: All dimensions are in millimeters (mm)

## Keying

### Keying angles

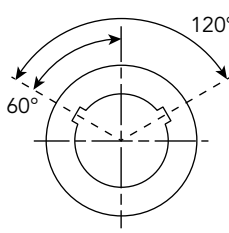
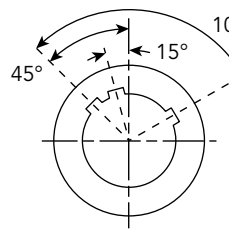
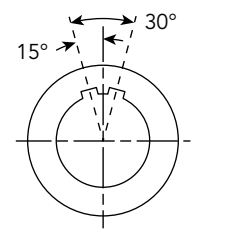
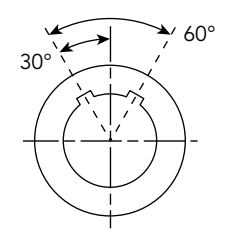
Key	T	U	A	B
Plug & Receptacle				

### Keying color codes

Keying	Contacts Standard Gender	Contacts Reverse Gender
T	Red	Purple
U	White	Yellow
A	Green	Orange
B	Blue	Light Brown



Mechanics

### Caps: an efficient protection against dust and water

Receptacle Caps		
Part Number	Shell Size	Description
JDXBRE0-1	0	Lanyard, w/Terminal
JDXBRE0-2	0	Lanyard, w/Crimp Ring
JDXBRE1-1	1	Lanyard, w/Terminal
JDXBRE1-2	1	Lanyard, w/Crimp Ring
JDXBRE2-1	2	Lanyard, w/Terminal
JDXBRE2-2	2	Lanyard, w/Crimp Ring

Lanyard, w/Terminal - 1

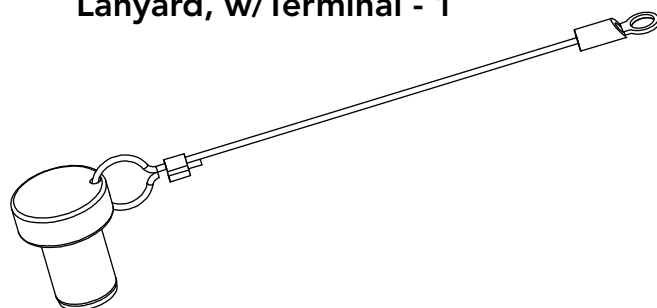

Lanyard, w/Crimp Ring - 2

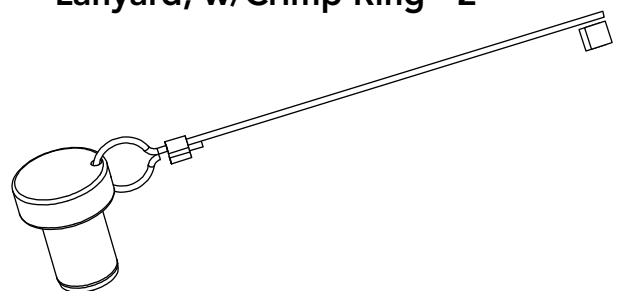

## Technical information

### Mechanical, Climatic, Electrical

Characteristics	Values	Standard	Method
Endurance	2,500 cycles	ANSI-EIA-364-D	9
Insulation Resistance	500 mΩ	ANSI-EIA-364-D	21
EMI Shielding	(60dB min. up to 100MHZ) (35dB min. up to 1GHz)	ANSI-EIA-364-D	66
Thermal Shock	-40°C to +125°C 5 cycles	ANSI-EIA-364-D	32
Mechanical Shock	300 g 3ms	ANSI-EIA-364-D	27
Vibrations	10 to 2000 Hzy - 15 g	ANSI-EIA-364-D	2005,1
Random Vibrations	-----	ANSI-EIA-364-D	28 test condition 4
Altituded Immersion	3 cycles (3*30min)	ANSI-EIA-364-D	3
Humidity	240 hours @ 40°C 90%RH	ANSI-EIA-364-D	31
Resistance to Fluids	Korosono JP8 (NATO code F34) Gasoline ASTM D 4914* Mineral Oil NATO code H515	ANSI-EIA-364-D	10
Protection Index	IP68 mated & unmated (1 meter, 1 hour)	IEC 529	14.2.8
Operating Temperature	-40°C to +125°C 5 cycles		

## Technical information

### Material

Component	Material	Standard	Surface treatment (µm)		
			Cr	Ni	Au
Shell	Brass	C38500/C3600	0.1 - 0.6	5 - 8	
Shell	Aluminum Contact Souriau for Availability & Part Number	ANSI 6061	0.1 - 0.6	5 - 8	
Nut	Brass	C38500/C3600	0.1 - 0.6	5 - 8	
Nut	Aluminum Contact Souriau for Availability & Part Number	ANSI 6061	0.1 - 0.6	5 - 8	
Pin Contact	Brass	C38500/C3600		3 - 5	0,5
Socket Contact	Copper Nickel	CAD C 19150		3 - 5	0,5
Clip	Beryllium Copper	17200			
Shielding Ring	Copper Alloy (Proprietary)	-		3 - 7	

### Technical Support

Descriptor	Standard JDX	Hybrid JDX
Shell Sizes	0, 1, 2	2
Number of Layouts	28	3
Number of Contacts	2 to 19	2P+6S, 2P+8S, 3P+6S
Termination Styles	Solder, PCB Contacts	Solder, PCB Contacts
Wire AWG Range	16 AWG to 30 AWG	16 AWG to 26 AWG
Current Rating	Up to 30A	Up to 26A
Insulator Material	PEEK	PEEK

# JDX SERIES



## JDX Breakaway Connectors

# Standard

■ JDX Standard Technical Information .....	18
■ Ordering Information .....	19
■ Dimensions.....	20-21
■ Contact Layouts.....	22-23
■ Contact & Wire Information .....	24



## Description

- A rugged sealed connector for high vibration and shock environments for both indoor and outdoor applications
- The Breakaway design eliminates the need for a manually operated latching system. It ensures a safe quick disconnect if cable becomes entangled
- Waterproof, IP68 (Mated and Unmated)
- Shell available in Brass and Lightweight Aluminum
- Available in Shell Size 0, 1, 2
- 28 Contact Layouts for multiple applications

## Applications

- SOURIAU Sealed connectors can be used in a variety of markets including Industrial, Instrumentation, Medical, Mil-Aero, Broadcast Entertainment and Telecommunications.

## Technical features

### Materials

- **Shell:** Brass or Aluminum
- **Shell Plating:** Black Chrome over Nickel
- **Insulator:** PEEK
- **Contacts:** Brass
- **Contacts Plating:** Gold over Nickel
- **Potting Seal:** Epoxy Potting Compound

### Electrical

- **Current Rating:** see chart on Page 22, 23 & 24
- **Contact Resistance:** see chart on page 24
- **Insulation Resistance:** 500 MΩ
- **Dielectric Withstanding Voltage:** see chart on Page 22 & 23
- **Operating Voltage:** see chart on Page 22 & 23

### Environmental

- **Operating Temperature:** -40°C to +125°C
- **Salt Spray Resistance:** 96 hours
- **Sealing:** IP68 (Mated & Unmated)
- **RoHS Compliant**

### Mechanical

- **Endurance:** Shell: 2500 mating/unmating
- **Vibration:** 10 - 2000 HZ (per EIA 364)
- **Shock:** 50g duration 6ms (per EIA-364-D)
- Autoclavable

## Ordering Information

BASIC SERIES	JDX	FD	0	T	07	M	S	N	A
<b>Shells Type - Receptacle</b>									
EP – Front Panel Mount									
ER – Rear Panel Mount									
EZ – Rear Panel Mount PCB Capable, Protruding Front (With Grounding Pins)									
ED – Rear Panel Mount PCB Capable (With Grounding Pins)									
EE – Rear Panel Mount PCB Capable, Protruding Back (With Grounding Pins)									
**IL – In-Line Cable Receptacle									
<b>Shells Type - Plug</b>									
**FD – Straight Cable Plug									
FA – Front Panel Mount Plug									
FB – Rear Panel Mount Plug (With Grounding Pins)									
<b>Shell Size</b>									
0, 1, 2									
<b>Keying</b>									
T - U - A - B (See page 13 for more details)									
<b>Contact Layouts</b>									
0: 2, 3,4,5,6,7,8 position									
1: 2,3,4,5,6,7,8,10,12 position									
2: 2,3,4,5,6,7,8,10,12,16,18,19 position									
<b>Contact Type</b>									
M: Male									
F: Female									
<b>Contact Termination</b>									
S - Solder									
P - PCB Straight Tails									
*Q - PCB Right Angle Tails (only available in the EE shell with no grounding pins)									
<b>Surface Plating</b>									
N: Non Reflective Black Chrome over Nickel									
S: Chrome over Nickel									
<b>Shell Material</b> (Brass is standard material)									
A: Add A for Aluminum Shell									

\* Receptacles Shell Style EE only

\*\* FD and IL shell styles are supplied as overmolded cable assemblies or as stand alone connectors (strain relief boot not available for this product)

**Note:** Custom cable assemblies available for any cable product for any series.

Custom grommets and overmolds can be designed for any application.

## Dimensions

### Receptacles

EZ: Rear Panel Mount PCB Capable  
Protruding Front (With Grounding Pins)

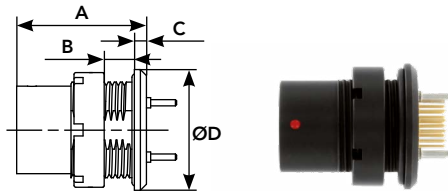

JDXEZ			
Size	0	1	2
A	18.7	Not developed	21.5
B	4.5		5.5
C	3		2
ØD	16		20

ER: Rear Panel Mount

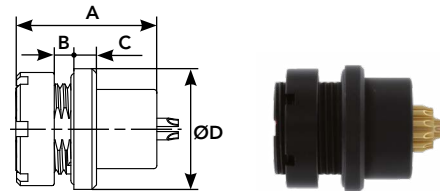

JDXER			
Size	0	1	2
A	18.7	20.9	21.5
B	2.7	3.7	6
C	3	3	3
ØD	16	16	20

ED: Rear Panel Mount PCB Capable  
(With Grounding Pins)

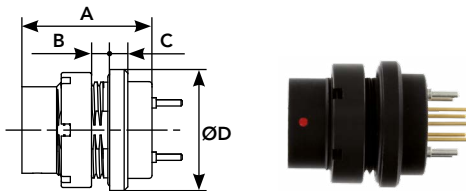

JDXED			
Size	0	1	2
A			21.5
B		Not Developed	3.1
C			3
ØD			20

EP: Front Panel Mount

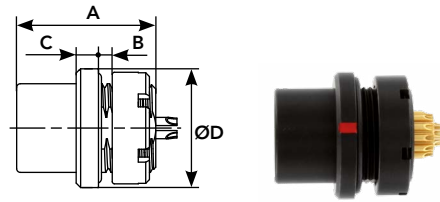

JDXEP			
Size	0	1	2
A	18.7	20.9	21.5
B	2.7	4.2	4
C	3	3	3
ØD	16	16	20

EE: Rear Panel Mount PCB Capable  
Protruding Back (With Grounding Pins)

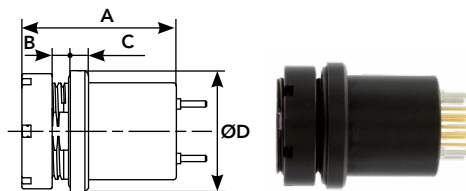

JDXEE			
SIZE	0	1	2
A			25,5
B		Not developed	2,6
C			3
ØD			20

IL: In-Line Cable Receptacle

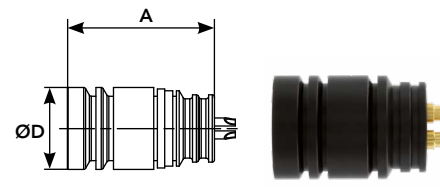

JDXIL			
Size	0	1	2
A	20.1	23.4	24
B	-	-	-
C	-	-	-
ØD	11.2	13.9	16.4

Note: All dimensions are in millimeters (mm)

## Dimensions

### Plugs

FD: Straight Cable Plug

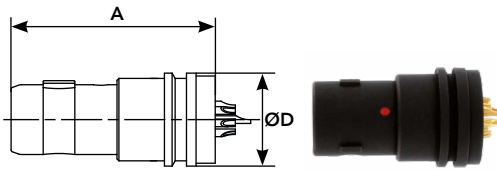

JDXFD			
Size	0	1	2
A	21.3	26	26.5
B	-	-	-
C	-	-	-
ØD	9,7	13	15.9

FA: Front Panel Mount Plug

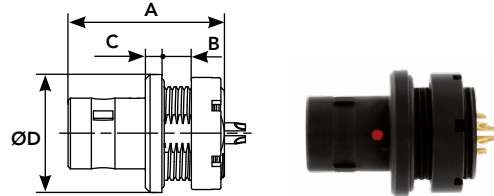

JDXFA			
Size	0	1	2
A	21,3	26	26,5
B	2,25	5,8	5,6
C	3	3	2,8
ØD	16	16	20

FB: Rear Panel Mount Plug  
(With Grounding Pins)

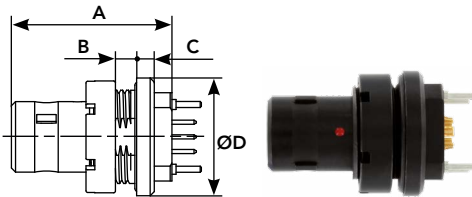

JDXFB			
Size	0	1	2
A	Not developed		27.27
B	Not developed		3
C	Not developed		3
ØD	Not developed		20

Panel Cut-Out - Size 0

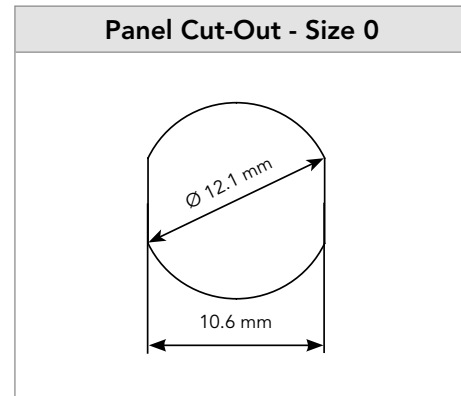

Panel Cut-Out - Size 1

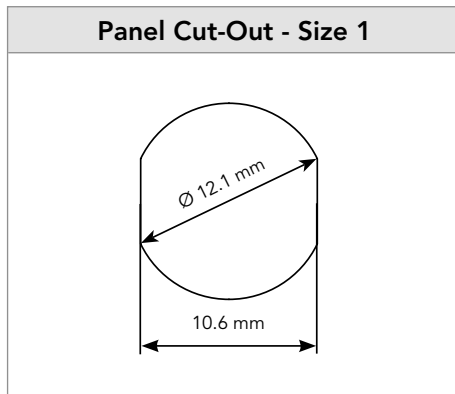

Panel Cut-Out - Size 2

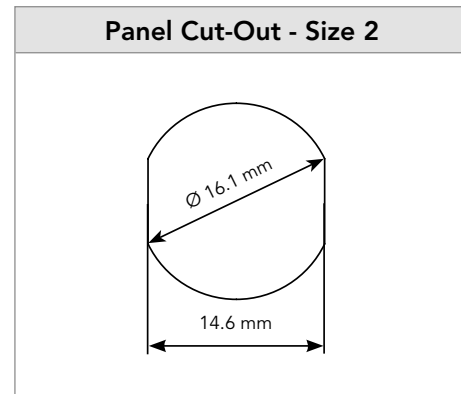

Note: All dimensions are in millimeters (mm)

## Contact layouts

### Voltage test procedure

The **testing voltage** corresponds to the maximum voltage the connector is able to withstand in normal climatic conditions. The value is about 75% of the electrical breakdown voltage. The testing voltage level can be reached several times in connectors life, but never applied for a continuous duration.

The **working voltage** corresponds to the maximum voltage the connector is able to withstand continuously during its life time, in real environmental conditions, even with high temperature. The value is around 1/3 of the testing voltage.

### Maximum current rating

This **indicated maximum current rating** corresponds to the maximum current that can be applied **simultaneously on each line of the connector mated pair**, continuously during its life time, in normal climatic conditions.

Remark : If the current is applied on only one contact of the layout, then an increased current value can be achieved over a long duration.







Shell size 0							
	02	03	04	05	06	07	08
Male Insulator Wire Side View							
Available Contact Style (N/A - Not Available)							
S - Solder	S	S	S	S	S	S	S
P - PCB straight tails	P*	P*	P*	P*	P*	P*	P*
Q - PCB right angles	Q**	Q**	Q**	Q**	N/A	N/A	N/A
Contact diameter mm	0,9	0,9	0,7	0,7	0,5	0,5	0,5
Solder Max. AWG	24	24	26	26	28	28	28
Max. current rating	10	8	7	6,5	2,5	2,5	2
Dielectric Withstanding Voltage (Vrms)	1400	1300	1350	800	680	680	680
Operating Voltage (Vdc/Vrms)	600/460	600/420	600/420	400/220	320/220	320/220	320/220







Shell size 1									
	02	03	04	05	06	07	08	10	12
Male Insulator Wire Side View									
Available Contact Style (N/A - Not Available)									
S - Solder	S	S	S	S	S	S	S	S	S
P - PCB straight tails	P*	P*	P*	P*	P*	P*	P*	P*	P*
Q - PCB right angles	N/A	N/A	Q**	Q**	Q**	Q**	Q**	N/A	N/A
Contact diameter mm	1,3	1,3	0,9	0,9	0,7	0,7	0,7	0,5	0,5
Solder Max. AWG	20	20	24	24	26	26	26	28	28
Max. current rating	15	12	10	9	7	7	5	2,5	2,5
Dielectric Withstanding Voltage (Vrms)	1600	1300	1900	1400	1400	1400	800	600	500
Operating Voltage (Vdc/Vrms)	760/530	600/420	900/630	660/460	600/460	600/460	600/420	300/200	275/175

\* Straight PCB tails with female contacts compatible with receptacles (EZ, ED and EE shell styles) and with plug (FB shell style).  
For all other reverse gender parts or for male PCB contacts please consult factory.  
\*\* Right Angle PCB Tails compatible with receptacle EE shell only, consult factory for availability.

**Note :** Contact numbering mating faces receptacle view: counterclockwise from key at position 1  
Contact numbering mating faces plug view: clockwise from key at position 1

## Contact layouts

Shell size 2						
	02	03	04	05	06	07
Male Insulator Wire Side						
Available Contact Style (N/A - Not Available)						
<b>S</b> - Solder	S	S	S	S	S	S
<b>P</b> - PCB straight tails	P*	P*	P*	P*	P*	P*
<b>Q</b> - PCB right angles	N/A	N/A	N/A	N/A	N/A	N/A
Contact diameter mm	2.0	1,6	1,3	1,3	1,3	1,3
Solder Max. AWG	16	18	20	20	20	20
Max. current rating	30	17	15	14	12	11
Dielectric Withstanding Voltage (Vrms)	2100	1700	2400	1900	1900	1500
Operating Voltage (Vdc/Vrms)	1000/700	830/560	1000/800	900/630	900/630	730/500

Shell size 2						
	08	10	12	16	18	19
Male Insulator Wire Side View						
Available Contact Style (N/A - Not Available)						
<b>S</b> - Solder	S	S	S	S	S	S
<b>P</b> - PCB straight tails	P*	P*	P*	P*	P*	P*
<b>Q</b> - PCB right angles	Q**	Q**	Q**	Q**	N/A	N/A
Contact diameter mm	0,9	0,9	0,7	0,7	0,7	0,7
Solder Max. AWG	24	24	26	26	26	26
Max. current rating	10	8	7	6	5,5	5
Dielectric Withstanding Voltage (Vrms)	1700	1700	1700	1500	1400	1400
Operating Voltage (Vdc/Vrms)	830/560	830/560	830/560	730/500	660/460	660/460

- \* Straight PCB tails with female contacts compatible with receptacles (EZ, ED and EE shell styles) and with plug (FB shell style).  
For all other reverse gender parts or for male PCB contacts please consult factory.
- \*\* Right Angle PCB Tails compatible with receptacle EE shell only, consult factory for availability.

**Note :** Contact numbering mating faces receptacle view: counterclockwise from key at position 1  
Contact numbering mating faces plug view: clockwise from key at position 1

### Contact & Wire Information

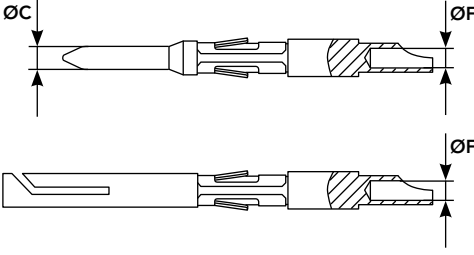
Solder Contacts	Shell Size	Contacts		Usable Cables		Max. Current Rating (A)	Contact Resistance (mΩ)	Endurance (Number of Cycles)	Recommended Strip Length "S" (mm)	
		ØC	ØF	Core Section (mm²)						AWG
				Min.	Max.					
	0	0,5	0,53	-	0,096	28	5	10	1000	2
		0,7	0,81	-	0,15	22	7	5	500 MAX.	3
		0,9	0,8	-	0,21	24	10	3,5	1000	3
	1	0,5	0,53	-	0,096	28	5	10	1000	2
		0,7	0,81	-	0,15	22	7	5	1000	3
		0,9	0,8	-	0,21	24	10	3,5	1000	3
	2	1,3	1,1	-	0,60	20	15	3	1000	3,5
		0,7	0,81	-	0,15	22	7	5	1000	3
		0,9	0,8	-	0,21	24	10	3,5	1000	3
		1,3	1,1	-	0,60	20	15	3	1000	3,5
		1,6	1,5	-	0,93	18	17	2,5	1000	4
	2,0	1,9	-	1,34	16	30	2,5	1000	4	

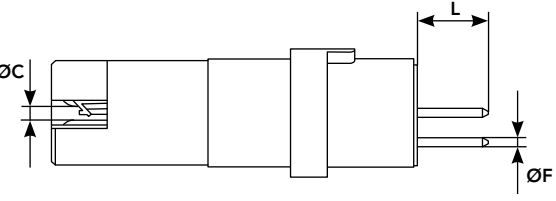
PCB Contacts	Shell Size	Contacts		Max. Current Rating (A)	Contact Resistance (mΩ)	Endurance (Numbers of Cycles)
		ØC	L			
	0	0,5	3,8	5	10	1000
		0,7	4,1	7	5	500 MAX.
		0,9	4,1	10	3,5	1000
	1	0,5	3,0	5	10	1000
		0,7	3,4	7	5	1000
		0,9	3,4	10	3,5	1000
		1,3	3,3	15	3	1000
	2	0,7	4,5	7	5	1000
		0,9	7,1	10	3,5	1000
		1,3	7,1	15	3	1000
		1,6	N/A	17	2,5	1000
		2,0	N/A	30	2,5	1000

\*For PCB contacts consult factory



## Notes

A large grid area for taking notes, consisting of 20 columns and 30 rows of small squares.

# JDX SERIES

## JDX Breakaway Connectors

# Hybrid (Signal+Power)

■ JDX Hybrid Technical Information .....	28
■ Ordering Information .....	29
■ Dimensions .....	30-31
■ Contact Layouts / Contact & Wire Information.....	32
■ Derating Curves .....	33
■ Existing Hybrid Part Numbers .....	34



## Description

- Mixed power & signal rugged sealed connector for high vibration and shock environments for both indoor and outdoor applications
- This new combination offered within one high density connector solution minimizes added componentry inventory, reduces system complexity and the subsequent consumption of valuable space and installation costs
- Waterproof, IP68 (Mated and Unmated)
- Shell available in Brass and Lightweight Aluminum
- Available in Shell Size 2
- 3 layouts for multiple applications:
  - 2P + 6S
  - 2P + 8S
  - 3P + 6S

## Technical features

### Materials

- **Shell:** Brass or Aluminum
- **Shell Plating:** Black Chrome over Nickel
- **Insulator:** PEEK with 15% Glass filled
- **Contacts:** Brass
- **Contacts Plating:** Gold over Nickel
- **Potting Seal:** Epoxy Potting Compound

### Electrical

- **Current Rating:** see chart on Page 32 & 33
- **Contact Resistance:** see chart on Page 32
- **Insulation Resistance:** 500 MΩ
- **Dielectric Withstanding Voltage:** see chart on Page 32
- **Operating Voltage:** see chart on Page 32

### Environmental

- **Operating Temperature:** -40°C to +125°C
- **Salt Spray Resistance:** 96 hours
- **Sealing:** IP68 (Mated & Unmated)
- **RoHS Compliant**

### Mechanical

- **Endurance:**  
Shell: 2500 mating/unmating
- **Vibration:** 10 - 2000 HZ  
(per EIA 364)
- **Shock:** 50g duration 6ms  
(per EIA-364-D)
- Autoclavable

## Ordering Information

<b>BASIC SERIES</b>	<b>JDX</b>	<b>FD</b>	<b>2</b>	<b>T</b>	<b>001</b>	<b>M</b>	<b>S</b>	<b>N</b>	<b>A</b>
<b>Shells Type - Receptacle</b>									
EP – Front Panel Mount									
ER – Rear Panel Mount									
EZ – Rear Panel Mount PCB Capable, Protruding Front (With Grounding Pins)									
ED – Rear Panel Mount PCB Capable (With Grounding Pins)									
EE – Rear Panel Mount PCB Capable, Protruding Back (With Grounding Pins)									
*IL – In-Line Cable Receptacle									
<b>Shells Type - Plug</b>									
*FD – Straight Cable Plug									
FA – Front Panel Mount Plug									
FB – Rear Panel Mount Plug (With Grounding Pins)									
<b>Shell Size</b>									
2									
<b>Keying</b>									
T - U - A - B (see page 13 for more keying details)									
<b>Contact Layouts</b>									
001 - 2P + 6S (2 Power + 6 Signal)									
002 - 2P + 8S (2 Power + 8 Signal)									
003 - 3P + 6S (3 Power + 6 Signal)									
<b>Contact Type</b>									
M: Male									
F: Female									
<b>Contact Termination</b>									
S - Solder									
P - PCB Straight									
<b>Surface Plating</b>									
N: Non Reflective Black Chrome over Nickel									
S: Chrome over Nickel									
<b>Shell Material</b> (Brass is standard material)									
A: Add A for Aluminum Shell									

\* FD and IL shell styles are supplied as overmolded cable assemblies or as stand alone connectors (strain relief boot not available for this product)

**Note:** Custom cable assemblies available for any cable product for any series.

Custom grommets and overmolds can be designed for any application.

## Dimensions

### Receptacles

EZ: Rear Panel Mount PCB Capable  
Protruding Front (With Grounding Pins)

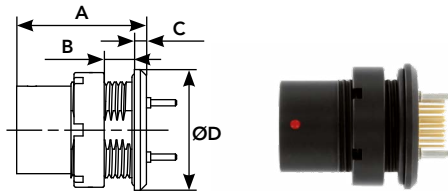

JDXEZ			
Size	0	1	2
A	Not developed		21.5
B	Not developed		5.5
C	Not developed		2
ØD	20		

ER: Rear Panel Mount

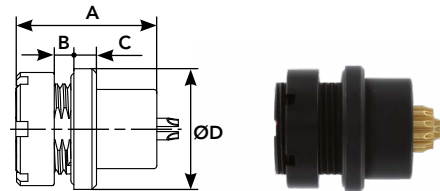

JDXER			
Size	0	1	2
A	Not developed		21.5
B	Not developed		6
C	Not developed		3
ØD	20		

ED: Rear Panel Mount PCB Capable  
(With Grounding Pins)

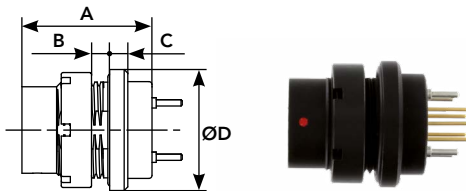

JDXED			
Size	0	1	2
A	Not Developed		21.5
B	Not Developed		3.1
C	Not Developed		3
ØD	20		

EP: Front Panel Mount

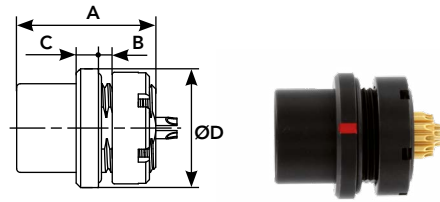

JDXEP			
Size	0	1	2
A	Not developed		21.5
B	Not developed		4
C	Not developed		3
ØD	20		

EE: Rear Panel Mount PCB Capable  
Protruding Back (With Grounding Pins)

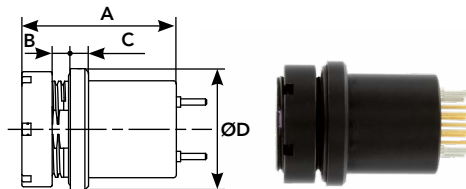

JDXEE			
SIZE	0	1	2
A	Not developed		25,5
B	Not developed		2,6
C	Not developed		3
ØD	20		

IL: In-Line Cable Receptacle

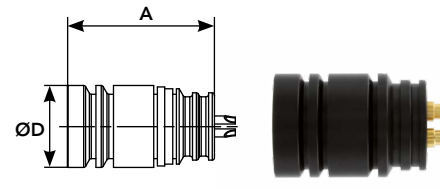

JDXIL			
Size	0	1	2
A	Not developed		24
B	Not developed		-
C	Not developed		-
ØD	16.4		

Note: All dimensions are in millimeters (mm)

## Dimensions

### Plugs

FD: Straight Cable Plug

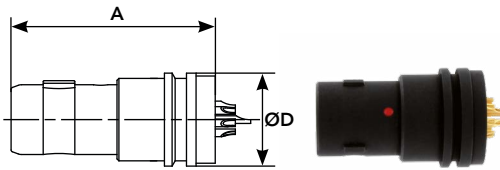

JDXFD			
Size	0	1	2
A	Not developed		26,5
B	Not developed		-
C	Not developed		-
ØD	Not developed		15,9

FA: Front Panel Mount Plug

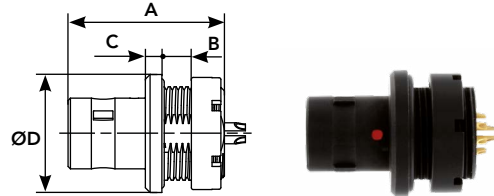

JDXFA			
Size	0	1	2
A	Not developed		26,5
B	Not developed		5,6
C	Not developed		2,8
ØD	Not developed		20

FB: Rear Panel Mount Plug  
(With Grounding Pins)

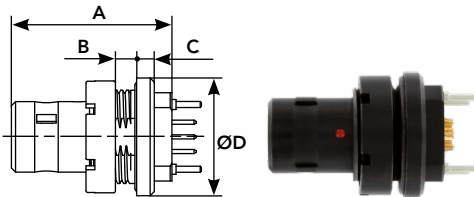

JDXFB			
Size	0	1	2
A	Not developed		27,27
B	Not developed		3
C	Not developed		3
ØD	Not developed		20

Panel Cut-Out - Size 0

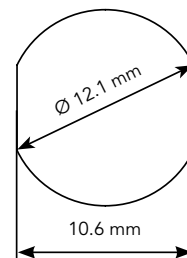

Panel Cut-Out - Size 1

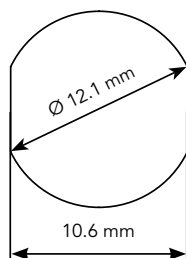

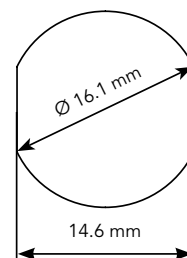

Panel Cut-Out - Size 2

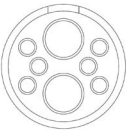

Note: All dimensions are in millimeters (mm)

## Contact Layouts & Technical Information

Shell size 2	2P+6S	2P+8S	3P+6S
<b>Male Insulator Wire Side</b>			
<b>Available Contact Style</b> (N/A - Not Available)			
S - Solder	S	S	S
P - PCB straight tails	P*	P*	P*
<b>Contact diameter (mm)</b>			
Power contact diameter (mm)	2.0	1,6	1,3
Signal contact diameter (mm)	0.7	0,7	0,7
<b>Solder Wire Max. AWG</b>			
Power Solder wire Max. AWG	16	18	20
Signal Solder wire Max. AWG	26	26	26
<b>Current Rating</b>			
Power current rating	See Derating Curve on page 33		
Signal current rating	See Derating Curve on page 33		
<b>Contact Resistance (mΩ)</b>			
Power contact Resistance (mΩ)	2,5	2,5	3
Signal contact resistance (mΩ)	5	5	5
<b>Dielectric Withstanding Voltage</b>			
Operating Voltage (Vdc/Vrms)	700/500	700/500	700/500

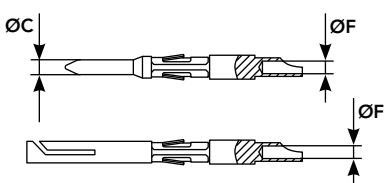
Solder Contacts	Shell Size	Contacts		Usable Cables		Max. Current Rating (A)	Contact Resistance (mΩ)	Endurance (Number of Cycles)	Recommended Strip Length "S" (mm)	
		ØC	ØF	Core Section (mm <sup>2</sup> )						AWG
				Min.	Max.					
	2	0,7	0,81	-	0,15	22	7	5	1000	3
		0,9	0,8	-	0,21	24	10	3,5	1000	3
		1,3	1,1	-	0,60	20	15	3	1000	3,5
		1,6	1,5	-	0,93	18	17	2,5	1000	4
		2,0	1,9	-	1,34	16	30	2,5	1000	4

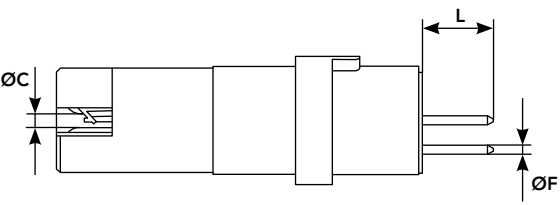
PCB Contacts	Shell Size	Contacts		Max. Current Rating (A)	Contact Resistance (mΩ)	Endurance (Number of Cycles)
		ØC	L			
	2	0,7	4,5	7	5	1000
		0,9	7,1	10	3,5	1000
		1,3	7,1	15	3	1000
		1,6	N/A	17	2,5	1000
		2,0	N/A	30	2,5	1000

\*Straight PCB tails with female contacts compatible with receptacles (EZ, ED and EE shell styles) and with plug (FB shell style). For all other reverse gender parts or for male PCB contacts please consult factory.



## Technical Information

### 2P + 6S

**Connector rating:**

- Power Contact: 26A at 30°C T-Rise
- Signal Contact: 2A

**Connector layout:**

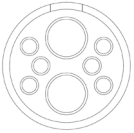

**Power Derating curve - Signal Contact Fixed at 2A**

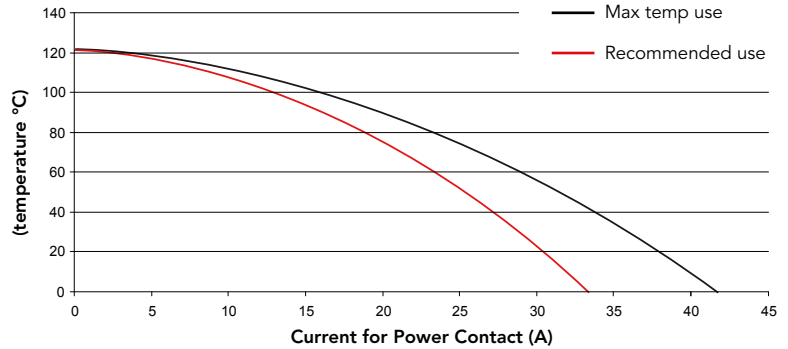

Signal Contact (cable awg 26) is powered at 2A  
Power Contact (cable awg 16): 0 to 40A

### 2P + 8S

**Connector rating:**

- Power Contact: 26A at 30°C T-Rise
- Signal Contact: 2A

**Connector layout:**



**Power Derating curve - Signal Contact Fixed at 2A**

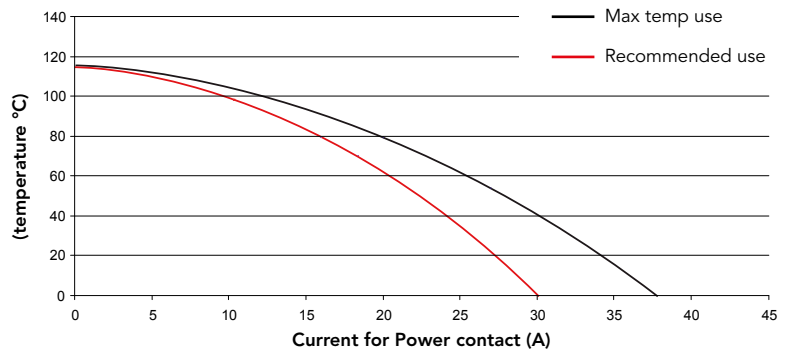

Signal Contact (cable awg 26) is powered at 2A,  
Power Contact (cable awg 18): 0 to 35A

### 3P + 6S

**Connector rating:**

- Power Contact: 17A at 30°C T-Rise
- Signal Contact: 2A

**Connector layout:**



**Power Derating curve - Signal Contact Fixed at 2A**

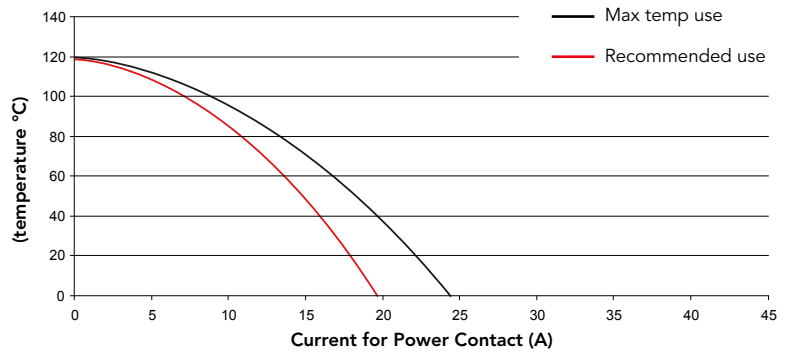

Signal Contact (cable awg 26) is powered at 2A,  
Power Contact (cable awg 20): 0 to 25A

## Part Numbers

### Existing Hybrid Shell Style Part Numbers

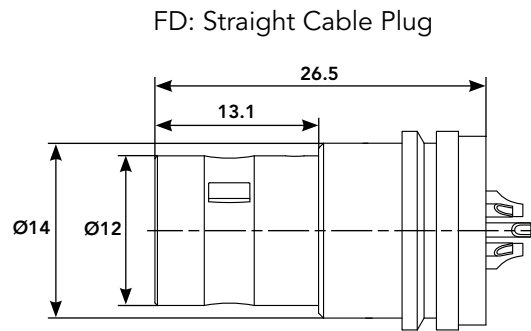
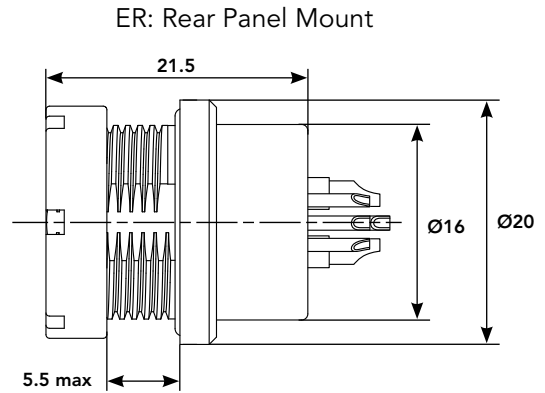

**Please note:**

FD Straight Plug is supplied as overmolded cable assembly or as stand alone connector (strain relief boot not available for this product)

For other shell styles & part numbers see shell styles on page 12 and part number configurator on page 29.

Part Number	Description	Shell Style	Shell Size	Shell Type
JDXFD2T001MSN	2 Power / 6 Signal (2P + 6S)	FD	2	Plug
JDXFD2T002MSN	2 Power / 8 Signal (2P + 8S)	FD	2	Plug
JDXFD2T003MSN	3 Power / 6 Signal (3P + 6S)	FD	2	Plug
JDXER2T001FSN	2 Power / 6 Signal (2P + 6S)	ER	2	Receptacle
JDXER2T002FSN	2 Power / 8 Signal (2P + 8S)	ER	2	Receptacle
JDXER2T003FSN	3 Power / 6 Signal (3P + 6S)	ER	2	Receptacle





Your local contact



Our contribution to environmental protection:  
This catalog is printed on PEFC certified paper  
Advancement of sustainable wood cultivation. [www.pefc.org](http://www.pefc.org)

# SOURIAU

[souriau.com](http://souriau.com)

[technical-emear-ect@esterline.com](mailto:technical-emear-ect@esterline.com) (Europe - Asia - Africa)

[technical-americas-ect@esterline.com](mailto:technical-americas-ect@esterline.com) (North America)

