

Flow Dividers

Priority, Proportional, Variable
Priority and Load Sensing
Priority Flow Dividers



Powering Business Worldwide

Flow Dividers

Priority, Proportional, Variable Priority, and Load Sensing

Priority Flow Dividers



Eaton® Flow Dividers are available in priority, proportional, variable and load sensing versions with a wide range of standard flow ratings and relief settings. Many are also available in either adjustable or non-adjustable versions, thus providing multiple configurations allowing the use of these products in virtually any mobile application.

Eaton load sensing priority valves provide dependable flow on demand for load sensing steering, braking or other priority functions while allowing excess flow to be used for auxiliary functions. Used with fixed or variable displacement pumps, a dynamic signal system increases machine performance and stability. Static signal systems are also available. Applications include ag tractors, motor graders, lift trucks, and backhoe/loaders.

Model 32306 Priority Flow Divider	3
Model 32501 Proportional Flow Divider	4
Model 32700 Variable Priority Flow Control	5
Model VFA Priority Flow Dividers	6
– Non-adjustable Divider	
Model VFA Priority Flow Dividers (continued)	7
– Screwdriver adjustable	
– 350° Dial Adjustable	
Model F1217 Priority Flow Dividers	8
90° Lever Adjustable	
VL Load Sensing Priority Valves	9
Sample Circuits	10
Model VLC	
– Load Sensing Priority Valve	11
– Model VLC Bolt-on Load Sensing Priority Valve	
VLC Ordering Information/Order Numbers	12
Model VLC – Model Code	
Model VLE Load Sensing Priority Valve	13
VLE Order Information/Order Numbers	14
Model VLE – Model Code	15
Model VLH Load Sensing Priority Valve	16
Model VLH – Order Information/	16
Order Numbers	
Model VLH – Model Code	17
Relief Valve Setting Code	17
CF Relief Valve Pressure & CF Setting Code	18
for VFA and F1217 Flow Dividers	



Model 32306

Priority Flow Divider

Dimensions

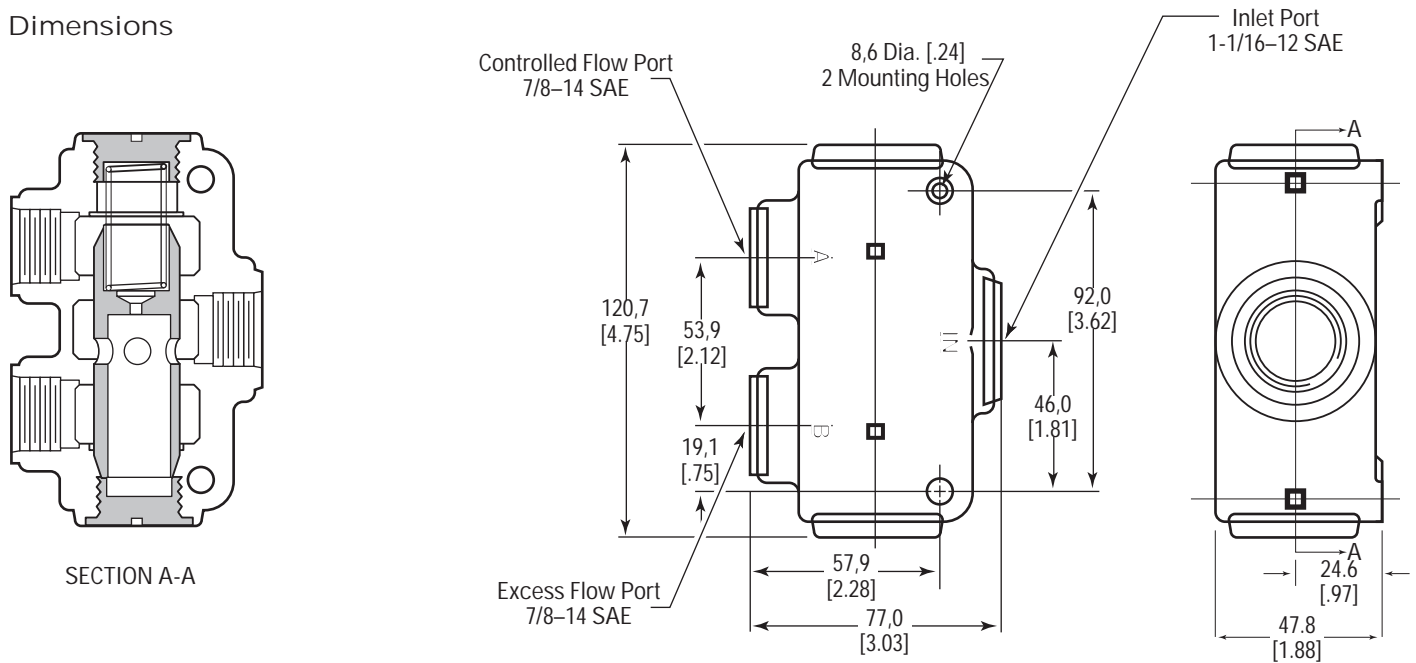

Neutral Flow Pressure Drop

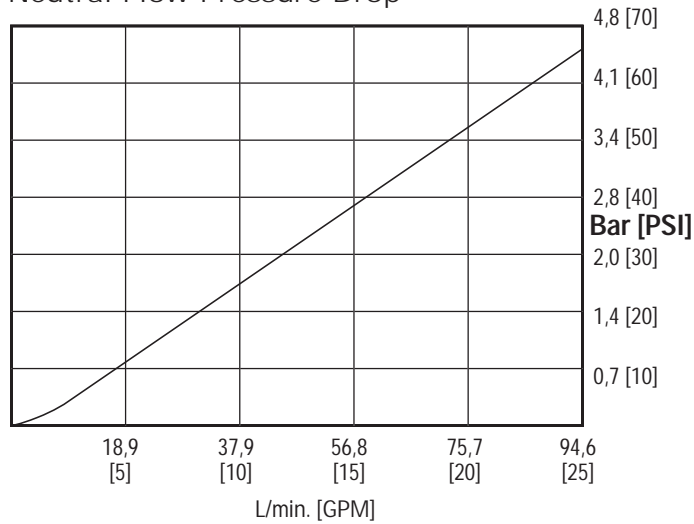

Note: All tests performed with oil viscosity 150 SUS @ 37,7C [100F] with oil temp @ 54,4C [130F].

Schematic

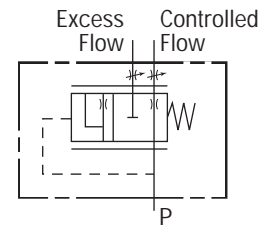

SPECIFICATIONS

Rated Input Flow	96.6 L/min. [25 G.P.M.]
Rated Pressure	172.4 bar [2500 PSI]
Maximum Pressure Drop Through Valve at Rated Input Flow	4.5 bar [65 PSI]
Weight	1.6 kg. [3.5 lbs.]
Paint	Primer

ORDERING INFORMATION

Order No.	32306-DAB	32306-DAC	32306-DAD
Controlled Flow Setting L/min. [G.P.M.]	11.4 [3]	18.9 [5]	26.5 [7]

Model 32501 Proportional Flow Divider

Dimensions

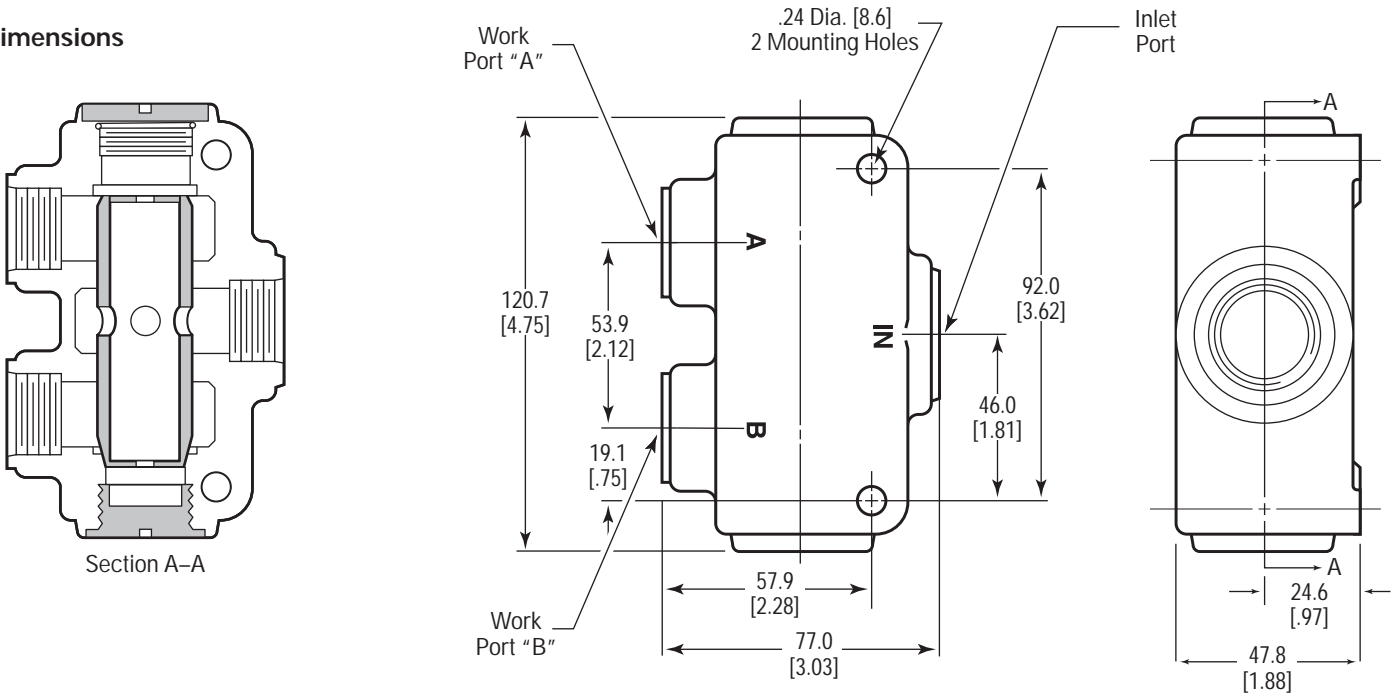

Schematic

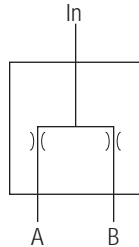

SPECIFICATIONS

Rated Input Flow	113.6 L/min. [30 G.P.M.]
Rated Pressure	172.4 bar [2500 PSI]
Maximum Pressure Drop Through Valve at Rated Input Flow	8.6 bar [125 PSI]
Weight	1.6 kg. [3.5 lbs.]
Paint	Primer

ORDERING INFORMATION

Maximum Input Flow L/min [G.P.M.]	Order Number	Flow Division Ratio		Inlet Port Size S.A.E.	Work Port "A" & "B" Size S.A.E.
		Port "A"	Port "B"		
37.9 [10]	32501-DAA	50%	50%	3/4-16	3/4-16
	32501-DAB	33%	67%		
75.7 [20]	32501-DAC	50%	50%	7/8-14	3/4-16
	32501-DAD	33%	67%		
113.6 [30]	32501-DAE	50%	50%	1-1/16-12	7/8-14
	32501-DAF	33%	67%		

Model 32700

Variable Priority

Flow Control

Dimensions

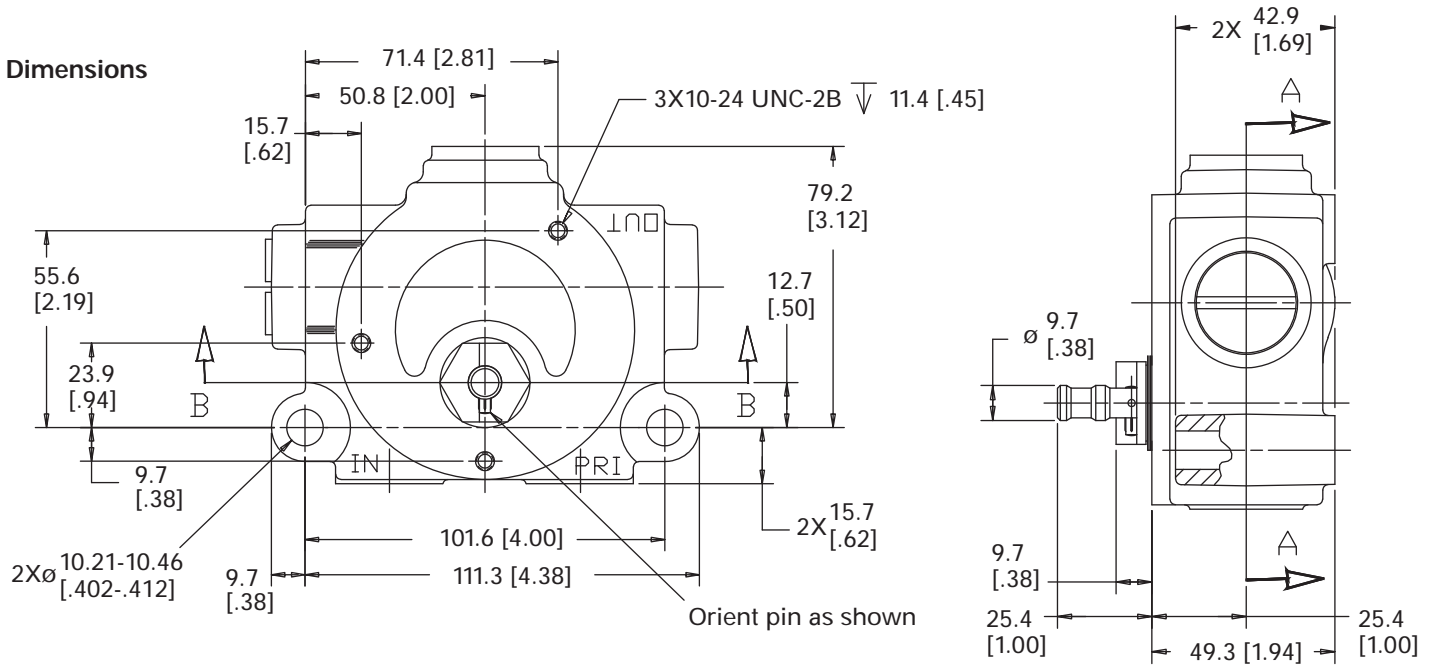

Note: Return port flow cannot be pressurized.

Neutral Flow Pressure Drop with Adjustable Orifice Open

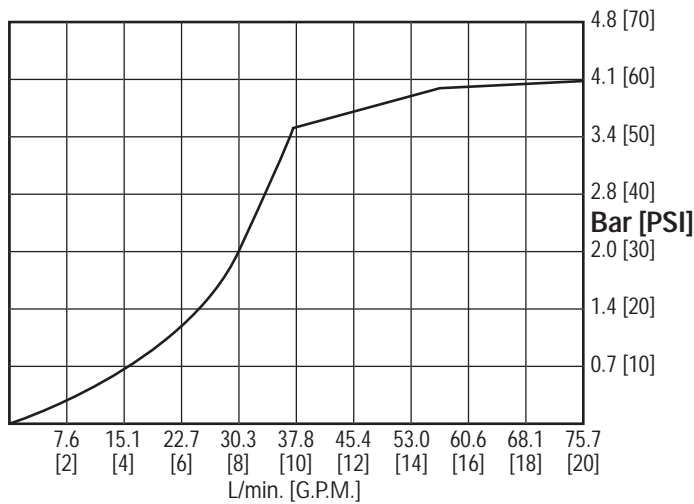

Note: All tests performed with oil viscosity 150 SUS @ 37.7C [100F] with oil temp @ 54.4C [130F].

Schematic

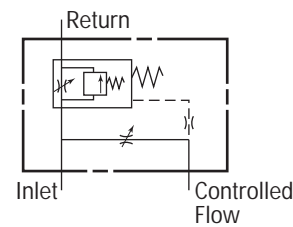

SPECIFICATIONS

Rated Input Flow	75.7 L/min. [20 G.P.M.]
Rated Pressure	172.4 bar [2500 PSI]
Maximum Pressure Drop Through Valve at 56.8 L/min. [15 G.P.M.] Input	4.0 bar [48 PSI]
Maximum Controlled Flow	36.0 L/min. [9.5 G.P.M.]
Controlled Flow Adjustment Range	5.7 L/min. [1.5 G.P.M.] to 36.0 L/min. [9.5 G.P.M.]
Relief Valve Factory Setting	151.7 bar [2200 PSI] @ 36.0 L/min. [9.5 G.P.M.]
Weight	2.04 kg. [4.5 lbs.]
Paint	Primer

ORDERING INFORMATION

Order No.	32700-DAA
-----------	-----------

Model VFA Priority Flow Dividers

Non-Adjustable Divider

Dimensions

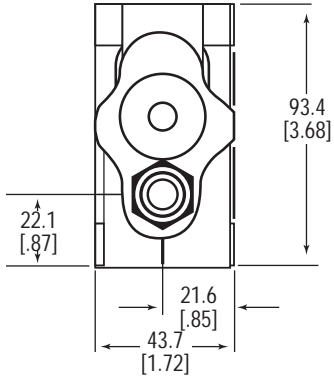
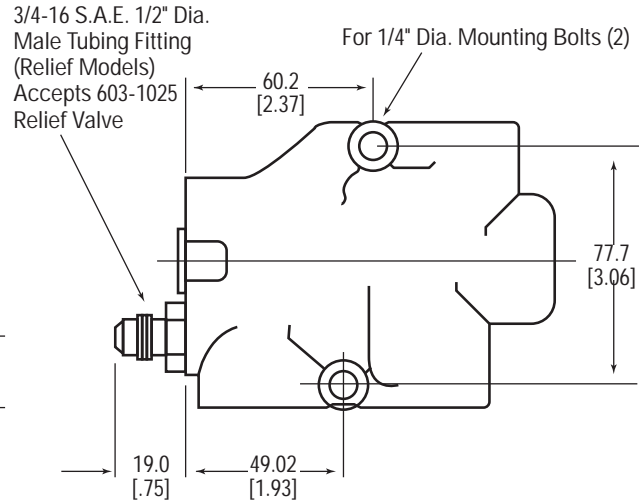
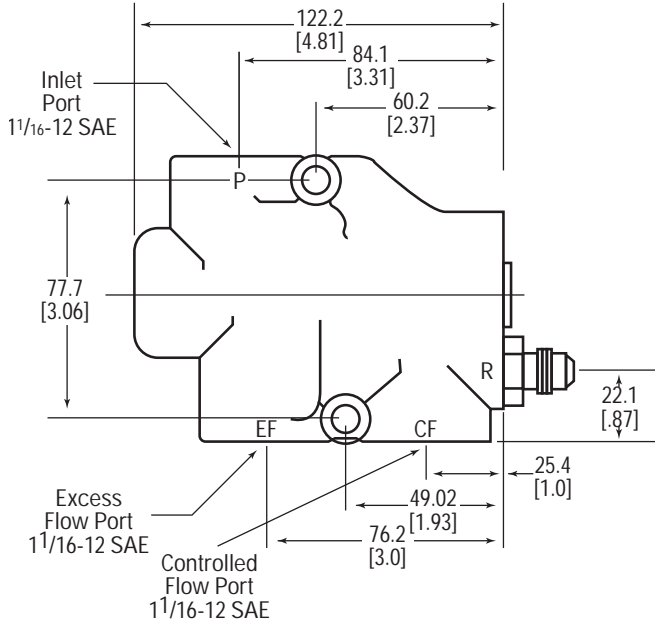

Schematics

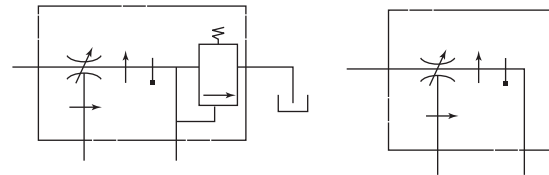

SPECIFICATIONS

Rated Input Flow	115 L/min. [30 G.P.M.]
Maximum Controlled Flow	75 L/min. [20 G.P.M.]
Rated Pressure	170 bar [2500 PSI]
Weight	3.2 kg. [7 lbs.]

Optional CF Relief Valve to 170 bar [2500 PSI]

ORDERING INFORMATION

Fixed CF Setting with Relief Valve	604-1106-001-XX*
Fixed CF Setting w/o Relief Valve	604-1102-001-XX*

* CF setting and CF relief valve pressure (if used) must be specified to determine two digit suffix code.

See page 17 for choosing the two digit relief valve pressure setting code.

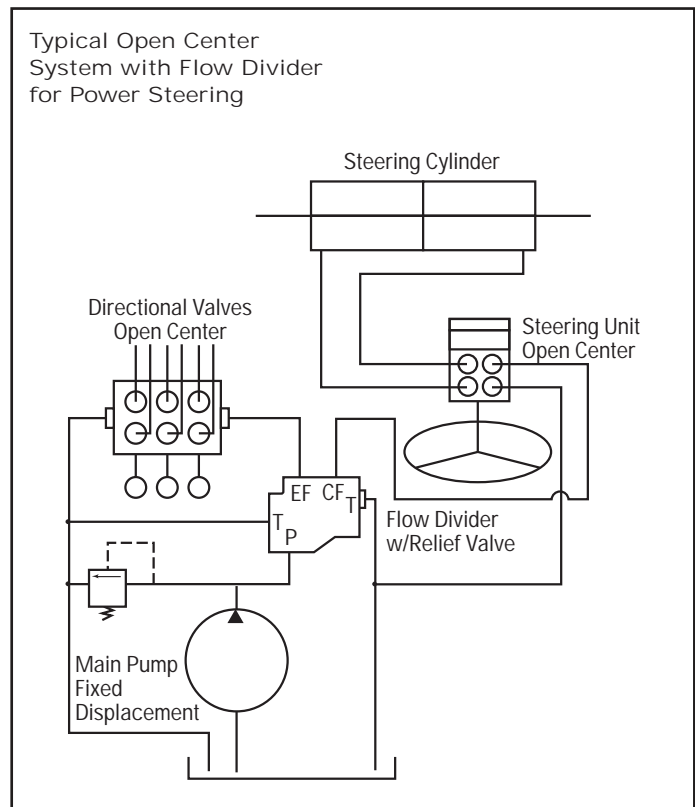

Model VFA Priority Flow Dividers

Screwdriver Adjustable
Controlled Flow to 12 G.P.M.

Dimensions

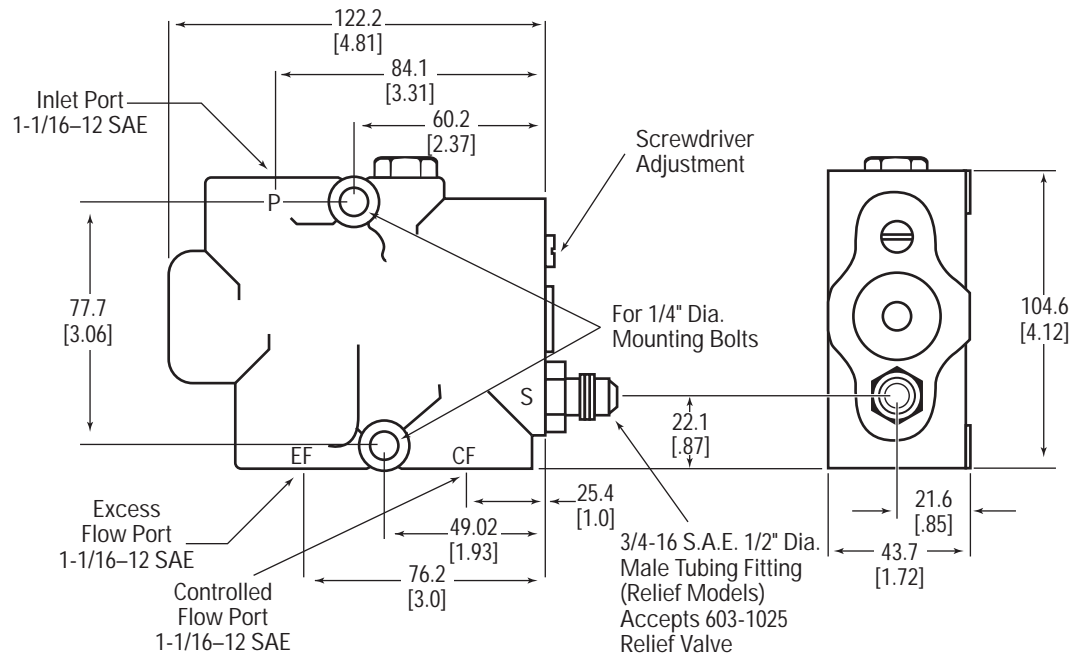

350° Dial Adjustable
Controlled Flow to 12 G.P.M.

Dimensions

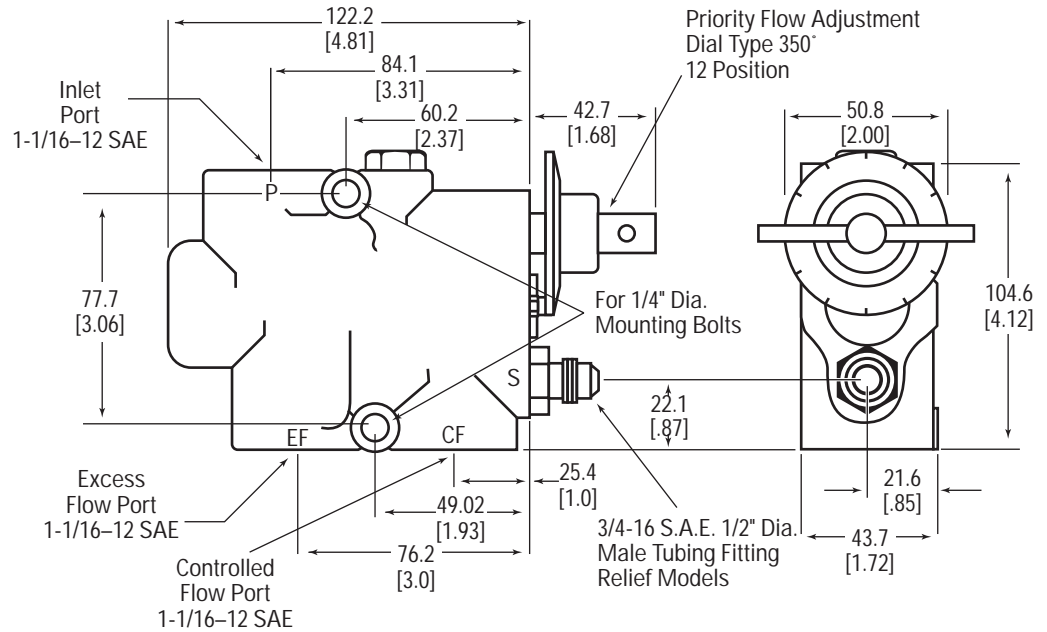

ORDERING INFORMATION

Screwdriver Adjust CF Setting w/o Relief Valve	604-1141-001-XA
Screwdriver Adjust CF Setting with Relief Valve	604-1142-001-XX*
350° Dial Adjust CF Setting w/o Relief Valve	604-1120-001-XA
350° Dial Adjust CF Setting with Relief Valve	604-1122-001-XX*

*CF setting and CF relief valve pressure (if used) must be specified to determine two digit suffix code.
See page 17 for choosing the two digit relief valve pressure setting code.

Model F1217

Priority Flow Dividers

Non-Adjustable

Dimensions

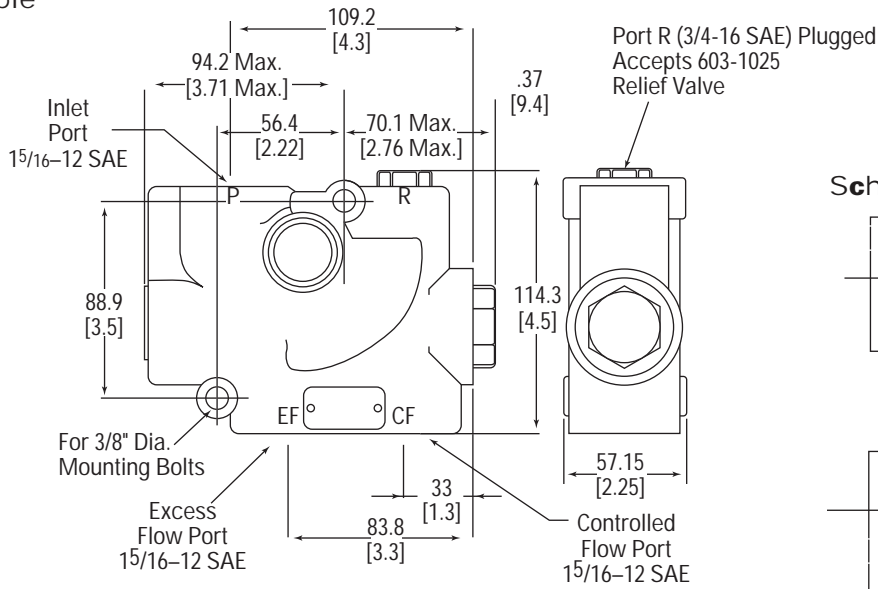

Schematics

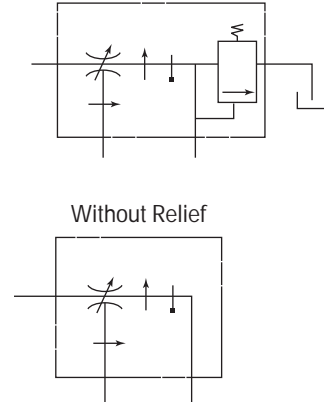

90° Lever Adjustable
Controlled Flow to 35 G.P.M.

Dimensions

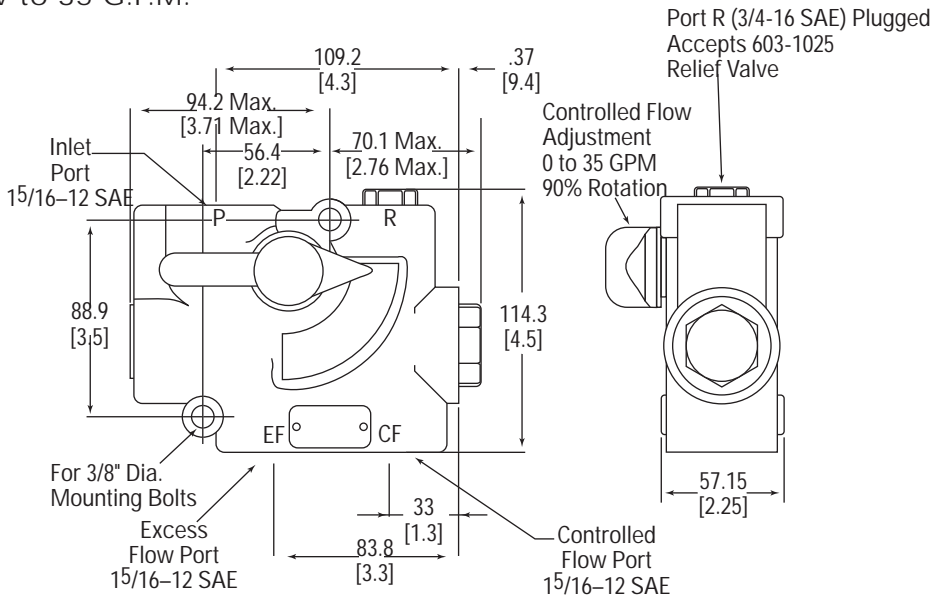

SPECIFICATIONS

Specifications	
Rated Input Flow	175 L/min. [45 G.P.M.]
Maximum Controlled Flow	135 L/min. [35 G.P.M.]
Rated Pressure	195 bar [2800 PSI]
Weight	4.1 kg. [9 lbs.]

ORDERING INFORMATION

Non-Adjustable Setting w/o Relief Valve	604-1037-002-XX*
90° Lever Adjust CF Setting w/o Relief Valve	604-1091-002-XA
90° Lever Adjust CF Setting with Relief Valve	604-1039-002-XX*

* CF setting and CF relief valve pressure (if used) must be specified to determine two digit suffix code.

See page 17 for choosing the two digit relief valve pressure setting code.

Optional CF Relief Valve to 170 bar [2500 PSI]

VL Load Sensing Priority Valves

Eaton® load sensing priority valves can be used with open center, closed center, or load sensing systems. Use in an open center system with a fixed displacement pump, or a closed center system with a pressure compensated pump, offers many of the features of a load sensing system. Excess flow is available for auxiliary circuits.

Priority valves are sized for design pressure drop at maximum pump output flow rate and priority flow requirements. The minimum control pressure must ensure adequate steering flow rate and must be matched with the steering control unit. The dynamic signal priority valve must be used with a dynamic signal steering control unit.

A pilot line is required to sense pressure downstream from the variable control orifice in the steering control unit. This is balanced by an internal passage to the opposite side of the priority valve. If there is an appreciable pressure drop (at the maximum steering rate) in the line between the CF port of the priority valve

and the P port of the steering unit due to remote location of the priority valve, a higher control pressure or a dynamic signal steering unit and priority valve must be used. Another alternative is the use of the external PP pilot option, with the pilot line connected as close as possible to the steering unit. The total system performance depends on careful consideration of the control pressure chosen and pressure drop in the CF line.

Eaton offers two types of load sensing signal systems: static and dynamic.

Static: Used for conventional applications in which response or circuit stability is not a problem. The load sensing pilot line should not exceed 2 meters [6 feet].

Dynamic: The dynamic signal system offers several advantages, including faster steering response, improved cold weather startup performance, and increased flexibility to optimize system performance and stability. Furthermore, it reduces the reverse flow through the steering unit (wheel kick), which can eliminate the

need for an inlet check valve. This design increases the CF spring differential by a “boost ratio” that is determined by the sizing of the orifices.

The priority (CF) circuit pilot relief valve must be factory set at least 20 bar [290 PSI] above the maximum steering pressure requirement. All of the flow other than the small pilot flow of the relief valve will be directed to the excess flow (EF) circuit when the CF relief setting is reached. A pump pressure compensator or master relief valve is required upstream of the priority valve. The compensator or relief must be set at least 10 bar [145 PSI] above the CF relief setting.

Schematics

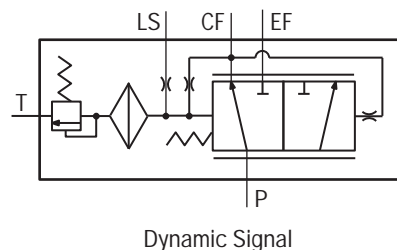
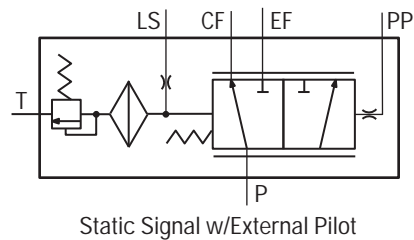
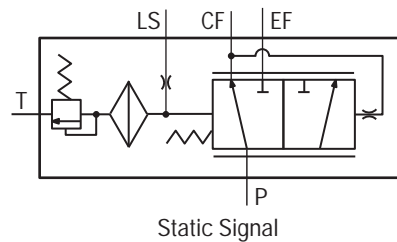

Sample Circuits

These sample circuit configurations show only a few applications possible with the VLC, VLE, and VLH priority valves. Your Eaton distributor can assist with your choice in valves for optimum performance.

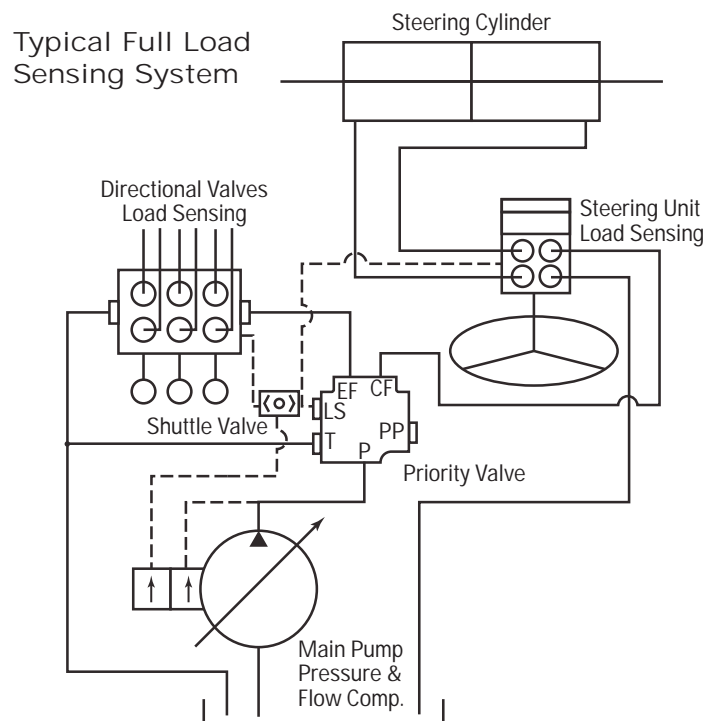
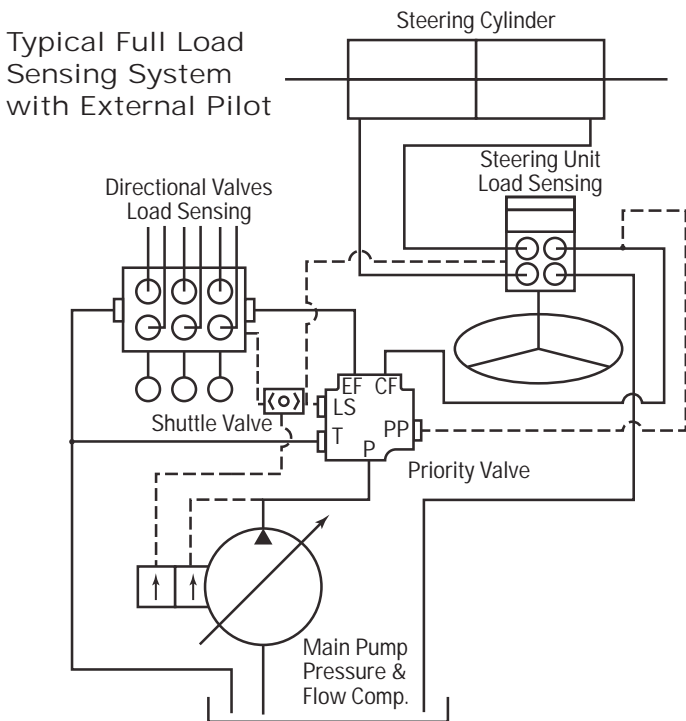
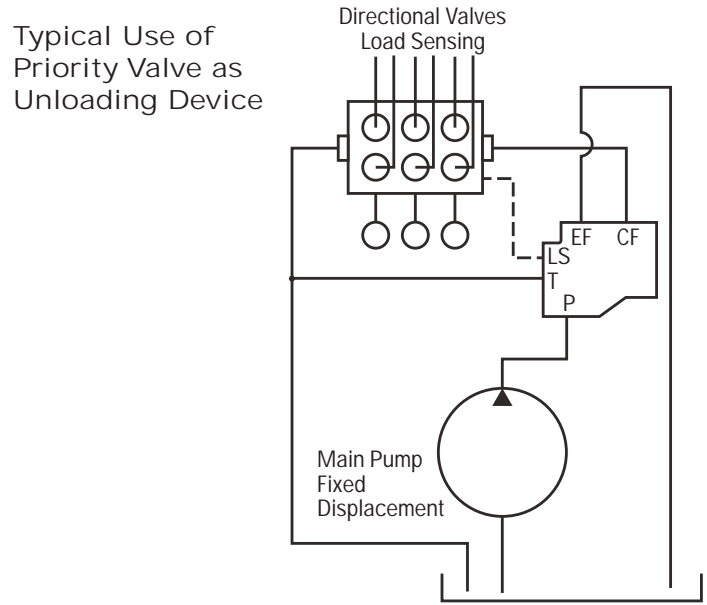
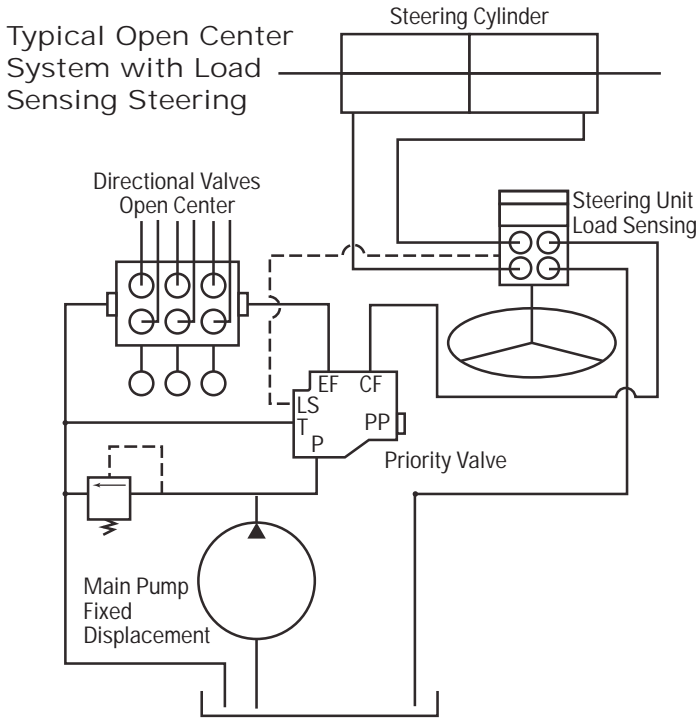

Model VLC

Load Sensing Priority Valves

Dimensions

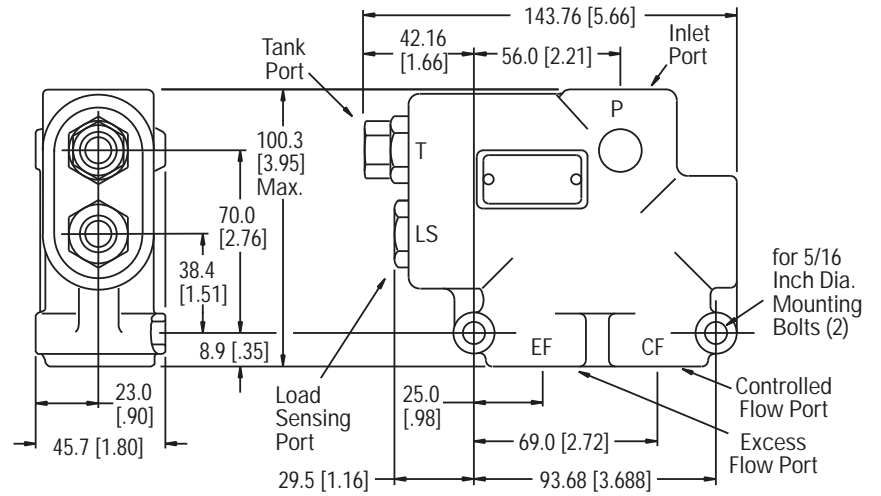

VLC P-EF Pressure Drop

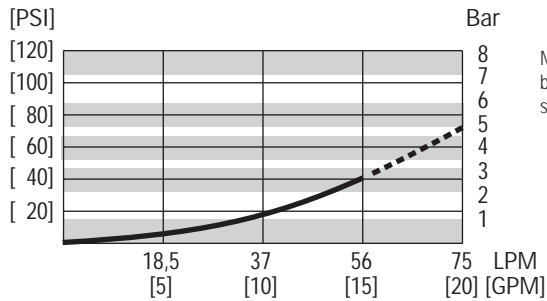

Minimum P port pressure will be equal to control pressure setting.

SPECIFICATIONS:
 NFPA Fatigue Rated P and EF Pressure
 NFPA Fatigue Rated CF Pressure

Rated Input Flow	60 L/min. [16 G.P.M.]
Rated Inlet and EF Pressure	276 bar [4000 PSI]
Rated CF Pressure	276 bar [4000 PSI]
Maximum CF Relief Setting	276 bar [4000 PSI]

Minimum Pressure Drop P - EF
 Oil Viscosity 25 cSt [120 SUS]

Bolt-on (Manifold Mount) Load Sensing Priority Valve

Dimensions

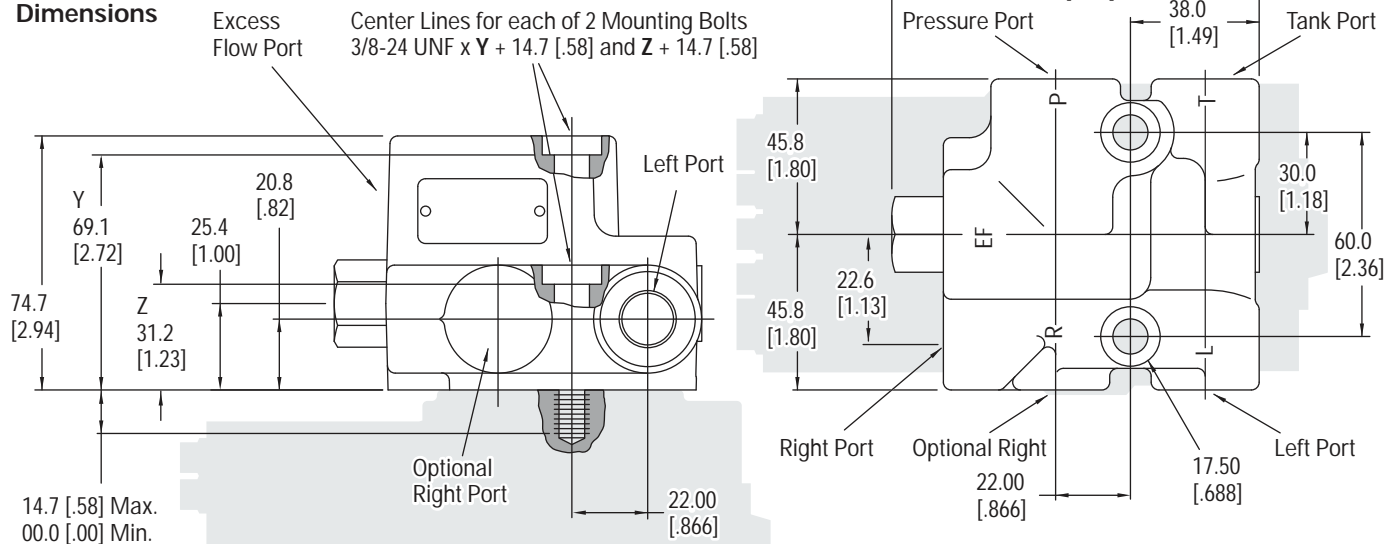

Model VLC

Ordering Information/ Order Numbers

			Signal Type & Control Pressure Bar [PSI]					
			Static	Dynamic	Static	Dynamic	Static	Dynamic
Configuration	Ports (5)	Port Size	3,5 [50]	5,2 [75]	5,2 [75]	7,6 [110]	6,9 [100]	10,0 [145]
Line	P & EF CF LS & T	7/8 - 14 3/4 - 16 7/16 - 20	606-1217	606-1232	606-1218	606-1314	606-1219	606-1315
Line	P & EF CF LS & T	3/4 - 16 9/16 - 18 7/16 - 20	606-1214	606-1327	606-1215	606-1278	606-1216	606-1328
Line	P & EF CF LS & T	M22 X 1,5 M18 X 1,5 M12 X 1,5	606-1329	606-1330	606-1331	606-1332	606-1333	606-1334
Line	P & EF CF LS & T	G1/2 - 14 G1/2 - 14 G1/4 - 19	606-1335	606-1336	606-1337	606-1338	606-1339	606-1340
Manifold (Metric)	P & EF T & L R (end)	G1/2 G3/8 G3/8				612-0001		
Manifold (Metric)	P & EF T, L & R (side)	G1/2 G3/8				612-0005		
Manifold (Series 10)	P & EF T, L & R (side)	G1/2 G3/8				612-1005		

Example: 606-1218-004-QA

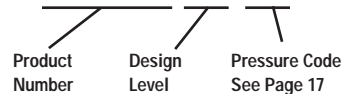

The example product number describes a VLC with 5,2 bar [75 PSI] control pressure, static signal, 7/8 – 14 P and EF ports, 3/4 – 16 CF port, 7/16 – 20 LS and T ports, 172 bar [2500 PSI] relief valve setting.

Model VLC - Model Code

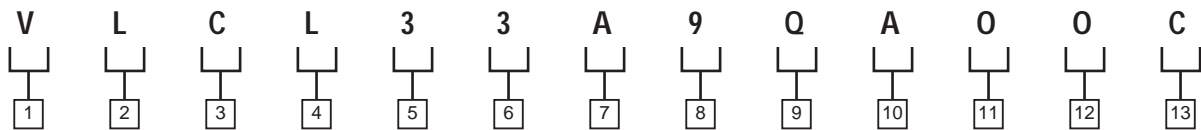

1 Product

V – Valve

2 Type

L – External pilot operated flow control (priority) valve

3 Inlet Flow Rating

C – 60.6 L/min. [16 G.P.M.]

4 Configuration

L – Line mount
M – Manifold mount (bolt-on to metric SCU)
S – Manifold mount to series 10 SCU

5 Ports

2 – CF 9/16, P & EF 3/4 – 16, LS & T, 7/16 – 20
3 – CF 3/4 - 16, P & EF 7/8 – 14, LS & T, 7/16 – 20
4 – CF M18 x 1.5, P & EF M22 x 1.5, LS & T, M12 x 1.5
5 – CF G1/2, P & EF G1/2, LS & T, G1/4
A – P & EF G1/2, T, L & R G3/8
B – P & EF M22 x 1.5, T, L & R M18 x 1.5
C – P & EF G1/2, L & R G3/8
D – P & EF 7/8 – 14, T, L & R 3/4 – 16
E – P & EF 7/8 – 14, T & L 3/4 – 16, R 3/4 – 16 (End)
F – P & EF G1/2, T & L G3/8, R G3/8 (End)

6 Pilot Signal

1 – LS pilot only – static
2 – PP and LS pilots – static
3 – LS pilot only – dynamic

7 Control Spring

6 – PP and LS pilots – dynamic
Z – 3.4 bar [50 lbf/in²]
A – 5.2 bar [75 lbf/in²]
B – 6.9 bar [100 lbf/in²]
C – 10.3 bar [150 lbf/in²]

8 Relief Valve

0 – None (solid plug)
4 – None (shipping plug)
9 – Inverted style cartridge

9, 10 Relief Setting

00 – None
XX – Setting per code on page 17

11 Special Features

0 – Static or Std. Dynamic with 1.45 Boost
A – Dynamic with 2.0 Boost
C – Dynamic with 1.64 Boost
D – Dynamic with 1.67 Boost

12 Paint

0 – Standard - painted black
G – Painted red oxide primer

13 Design Code

D – Fourth Design

Model VLE Load Sensing Priority Valve

Dimensions

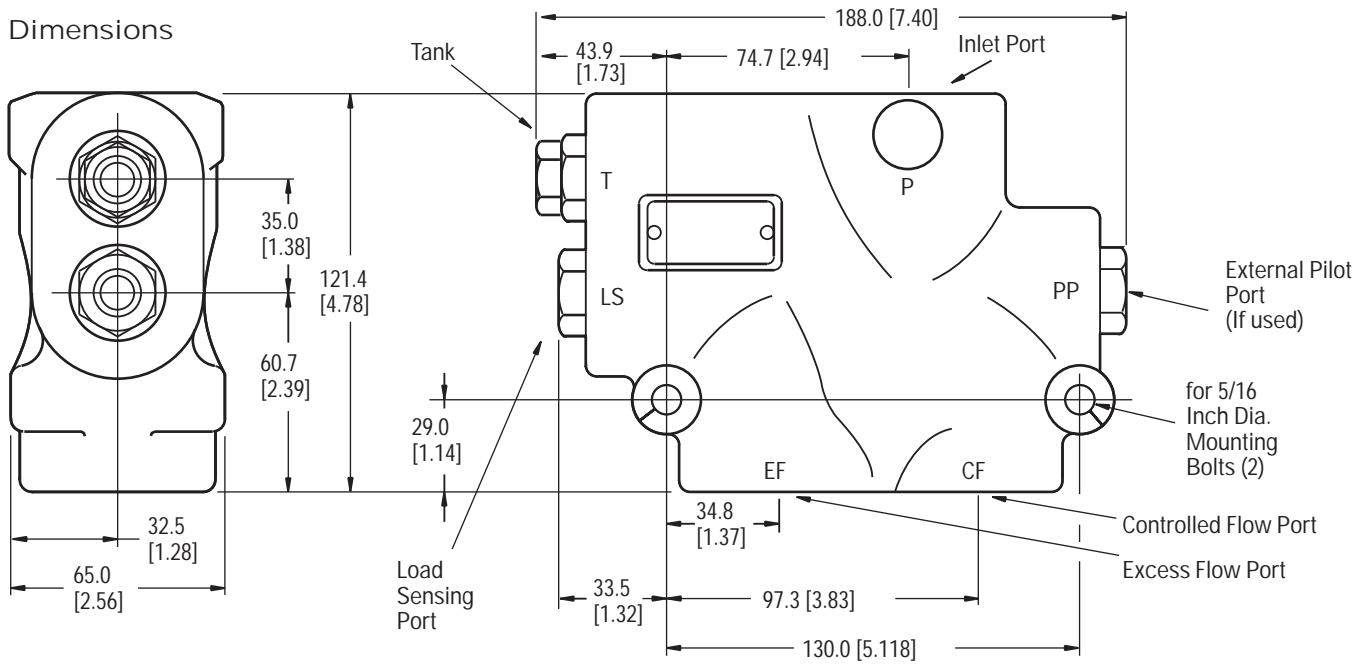

VLE P-EF Pressure Drop

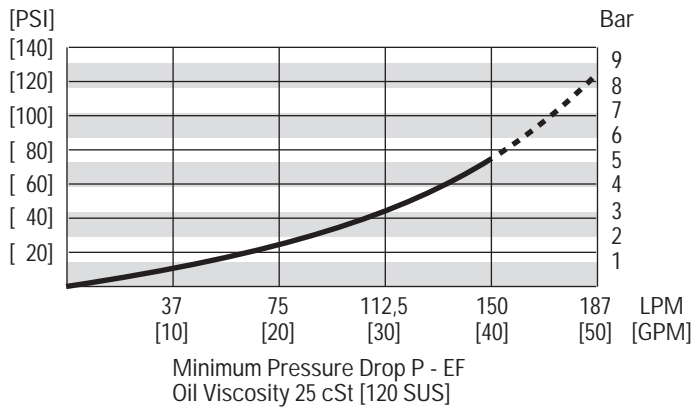

SPECIFICATIONS:
NFPA Fatigue Rated P and EF Pressure
NFPA Fatigue Rated CF Pressure

Rated Input Flow	150 L/min. [40 G.P. M.]
Rated Inlet and EF Pressure	310 bar [4500PSI]
Rated CF Pressure	276 bar [4000 PSI]
Maximum CF Relief Valve Setting	276 bar [4000 PSI]

Minimum P port pressure will be equal to control pressure setting.

Model VLE

Ordering Information/ Order Numbers

		Signal Type & Control Pressure Bar [PSI]					
		Static		Dynamic		Dynamic	
Ports (5)	Port Size	4,5 [65]	5,5 [80]	6,9 [100]	8,6 [125]	10,3 [150]	12,8 [185]
P & EF CF LS & T	1-1/16 - 12 3/4 - 16 7/16 - 20	606-1093	606-1294	606-1094	606-1295	606-1095	606-1296
P & EF CF LS & T	1-1/16 - 12 7/8 - 14 7/16 - 20	606-1046	606-1341	606-1047	606-1342	606-1048	606-1343
P & EF CF LS & T	1-5/16 - 12 7/8 - 14 7/16 - 20	606-1058	606-1344	606-1059	606-1345	606-1060	606-1346
P & EF CF LS & T	1-5/16 - 12 1-5/16 - 12 7/16 - 20	606-1141	606-1347	606-1142	606-1348	606-1143	606-1349
P & EF CF LS & T	1-5/16 - 12 1-1/16 - 12 7/16 - 20	606-1350	606-1282	606-1351	606-1281	606-1454	606-1323
P & EF CF LS & T	M27 X 2 M18 X 1,5 M12 X 1,5	606-1353	606-1354	606-1355	606-1356	606-1357	606-1358
P & EF CF LS & T	G3/4 - 14 G1/2 - 14 G1/4 - 19	606-1359	606-1360	606-1361	606-1362	606-1363	606-1364

Example

Example: 606-1094-003-QA

Product Number Design Level Pressure Code
See Page 17

The example product number describes a VLE with 6,9 bar [100 PSI] control pressure, static signal, 1-1/16 – 12 P and EF ports, 3/4 – 16 CF port, 7/16 – 20 LS and T ports, 172 bar [2500 PSI] relief valve setting.

Model VLE - Model Code

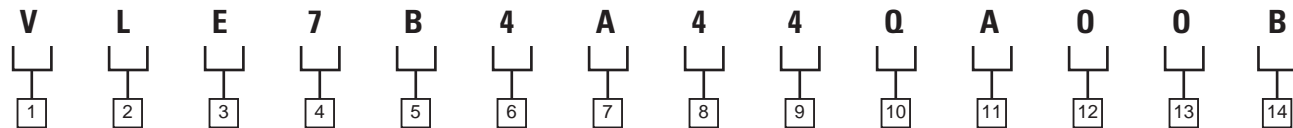

1 Product

V – Valve

2 Type

L – External pilot operated flow control (priority) valve

3 Inlet Flow Rating

E – 151 L/min. [40 G.P.M.]

4 Ports

1 CF 1-1/16 - 12, P & EF 1-5/16 - 12, LS & T 7/16 - 20
3 CF 3/4 - 16, P & EF 7/8 - 14, LS & T 7/16 - 20
4 CF 7/8 - 14, P & EF 1-1/16 - 12, LS & T 7/16 - 20
5 CF 7/8 - 14, P & EF 1-5/16 - 12, LS & T 7/16 - 20
6 CF 3/4 - 16, P & EF 1-1/16 - 12, LS & T 7/16 - 20
7 CF, P & EF 1-5/16 - 12, LS & T 7/16 - 20

9

CF 3/4 - 16, P & EF 1-5/16 - 12, LS & T 7/16 - 20

A

CF M18 x 1.5, P & EF M27 x 2, LS & T M12 x 1.5

B

CF G1/2, P & EF G3/4, LS & T G1/4

C

CF M22x1.5, P & EF M27x2, LS & T M14x1.5

5 Metering Type

O Standard
A High flow CF
B Double EF land, tapered
C Double EF land, notched
D High gain, straight land
E EF slots don't close completely

6 Pilot Signal

1 LS pilot only – static
2 PP & LS pilots – static
3 LS pilot only – dynamic
4 PP & LS pilots – dynamic

7 Control Spring

A 4.5 bar [65 lbf/in²]
B 6.9 bar [100 lbf/in²]
C 10.3 bar [150 lbf/in²]

8 Relief Valve

0 None (solid plug)
4 Inverted style cartridge

9 Relief Dashpot

0 None (Std. with relief valve) or none (Std. with no relief valve)
4 0.67 [.0265] Dia. (Standard with inverted relief valve)

10-11 Relief Setting

00 None
XX Setting per code on page 17

12 Special Features

O LS & PP - .91 [.036] Dia.
D LS & PP - .79 [.031] Dia.
E Dynamic with 1.19 Boost
F PP- .79 (.031) Dia. Dynamic with 1.08 boost
G Dynamic with 1.37 Boost
H PP- .91 (.036) Dia. Dynamic with 1.08 Boost
N Dynamic with 1.42 Boost
P Dynamic with 1.23 Boost (Standard)
R PP- .91 (.036) Dia. Dynamic with 2.00 Boost
S Dynamic with 1.67 Boost
T PP- .64 (.025) Dia. Dynamic with 2.00 Boost

13 Paint

0 Standard - painted black
7 Painted red oxide primer

14 Design code

B – Second design

Model VLH Load Sensing Priority Valve

Dimensions

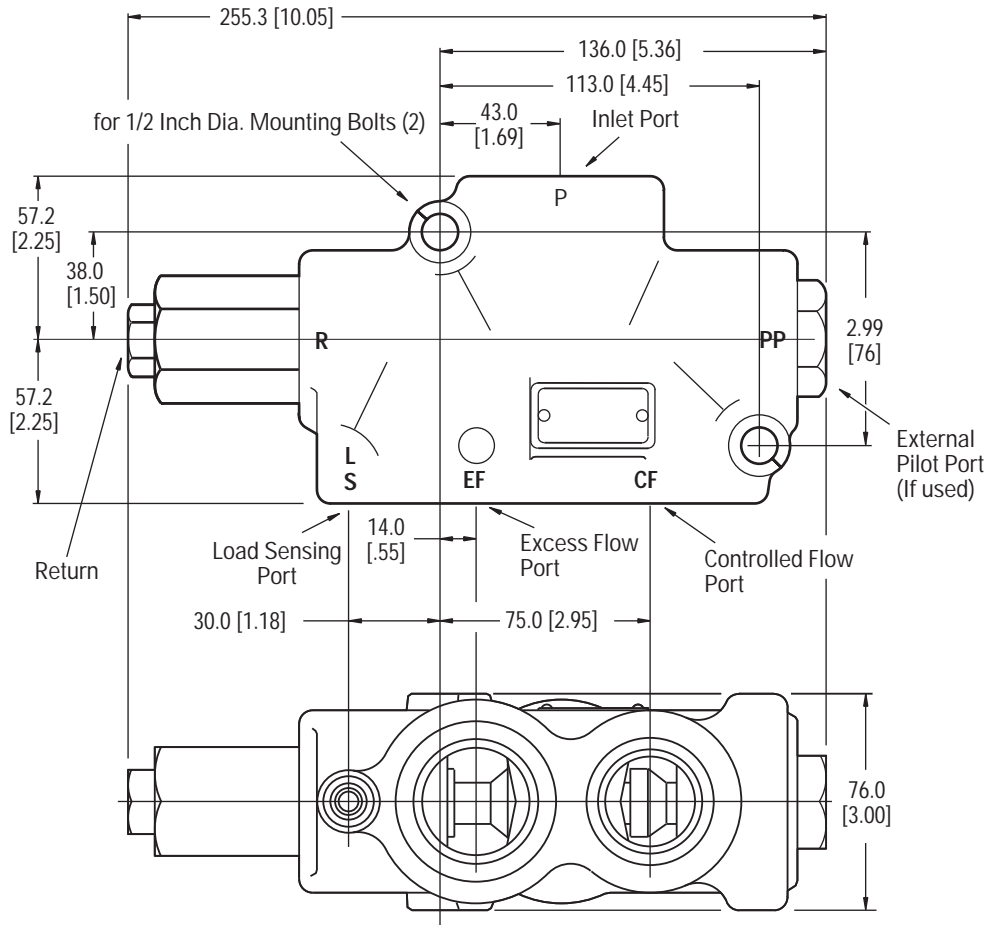

VLH P-EF Pressure Drop

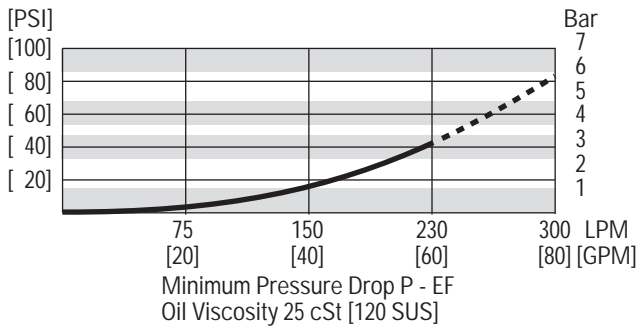

SPECIFICATIONS:

- NFPA Fatigue Rated P and EF Pressure
- NFPA Fatigue Rated CF Pressure

Rated Input Flow	240 L/min. [63 G.P.M.]
Rated Inlet and EF Pressure	297 bar [4300 PSI]
Rated CF Pressure	276 bar [4000 PSI]
Maximum CF Relief Setting	276 bar [4000 PSI]

Minimum P port pressure will be equal to control pressure setting.

Model VLH

Order Information/ Order Numbers

		Signal Type & Control Pressure Bar [PSI]					
		Static	Dynamic	Static	Dynamic	Static	Dynamic
Ports (5)	Port Size	4,5 [65]	5,5 [80]	6,9 [100]	8,6 [125]	10,3 [150]	12,8 [185]
P & EF CF LS & R	1-5/8 - 12 1-5/16 - 12 7/16 - 20	606-1201	606-1288	606-1202	606-1289	606-1203	606-1290
P & EF CF LS & R	1-5/8 - 12 1-1/16 - 12 7/16 - 20	606-1368	606-1316	606-1369	606-1285	606-1376	606-1286
P & EF CF LS & R	1-5/8 - 12 3/4 - 16 7/16 - 20	606-1189	606-1371	606-1190	606-1372	606-1191	606-1373

Example

Example: 606-1202-003-QA

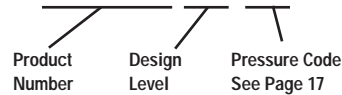

The example product number describes a VLH with 6,9 bar [100 PSI] control pressure, static signal, 1-5/8 - 12 P and EF ports, 1-5/16 - 20 CF port, 7/16 - 20 LS and T ports, 172 bar [2500 PSI] relief valve setting.

Model VLH - Model Code

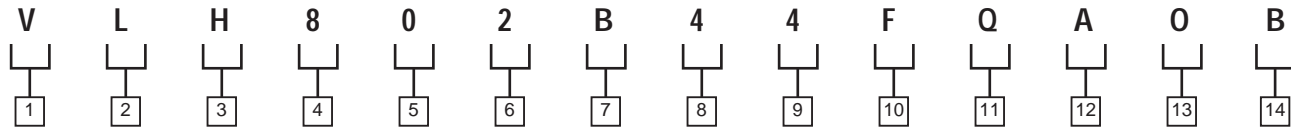

1 Product

V - Valve

2 Type

L - External pilot operated flow control (priority) valve

3 Inlet Flow Rating

H - 240 L/min. [63 G.P.M.]

4 Ports

7 CF 1-1/16 - 12, P & EF
1-5/8 - 12, LS & T 7/16 - 20

8 CF 3/4 - 16, P & EF 1-5/8 - 12, LS & T 7/16 - 20

9 CF 15/16 - 12, P & EF 1-5/8 - 12, LS & T 7/16 - 20

D CF 7/8-14, P&EF 1-5/8 - 12, LS&T 7/16 - 20

F CF M27 x 2, P&EF M33x2, LS & T M14x1.5

L CF M22 x 1.5, P&EF M42x2, LS & T M14x1.5

5 Adjustments

0 Non-adjustable

6 Pilot Signal

1 LS pilot only - static

2 PP & LS pilots - static

3 LS pilot only - dynamic

4 PP & LS pilots - dynamic

7 Control Spring

A 5.2 bar [75 lbf/in²]

B 6.9 bar [100 lbf/in²]

C 10.3 bar [150 lbf/in²]

D 14.5 bar [210 lbf/in²]

8 Relief Valve

0 None (solid plug)

4 Inverted style cartridge

9 Relief Dashpot

0 None (Std. with no relief valve)

4 0.67 [.0265] DIA. (Standard with inverted relief valve)

10-11 Relief Setting

00 None

XX Setting per code on page 17

12 Special Features

O LS & PP - 1.19 [.047] Dia.

A LS & PP - 0.58 [.023] Dia.

B LS & PP - 0.71 [.028] Dia.

C Dynamic with 1.37 Boost

D Dynamic with 1.23 Boost (Standard)

H Dynamic with 1.64 Boost

J Dynamic with 1.42 Boost

13 Paint

0 - Standard - painted black

14 Design Code

B - Second design

Relief Valve Setting Code

Use this chart to find the two digit suffix that corresponds to the nominal pressure setting. The factory pressure setting tolerance is -0 psi, +100 psi (-0 bar, +7bar).

Settings in bold print are preferred standard settings.

SUFFIX	BAR	PSI	SUFFIX	BAR	PSI	SUFFIX	BAR	PSI	SUFFIX	BAR	PSI
AA	17	250	GA	104	1500	SA	190	2750	ZA	276	4000
AB	19	275	GB	105	1525	SB	191	2775	ZB	279	4050
AC	21	300	GC	107	1550	SC	193	2800	ZC	283	4100
AD	23	325	GD	109	1575	SD	195	2825	ZD	286	4150
AE	24	350	GE	111	1600	SE	197	2850	ZE	290	4200
AF	26	375	HA	112	1625	TA	198	2875	ZF	293	4250
AG	28	400	HB	114	1650	TB	200	2900	ZG	297	4300
AH	29	425	HC	116	1675	TC	202	2925	ZH	300	4350
AJ	31	450	HD	117	1700	TD	204	2950	ZJ	304	4400
AK	33	475	HE	119	1725	TE	205	2975	ZK	307	4450
AL	35	500	JA	121	1750	UA	207	3000	ZL	311	4500
AM	36	525	JB	123	1775	UB	209	3025	ZM	314	4550
AN	38	550	JC	124	1800	UC	211	3050	ZN	317	4600
AP	40	575	JD	126	1825	UD	212	3075	ZP	321	4650
AQ	42	600	JE	128	1850	UE	214	3100	ZQ	324	4700
AR	43	625	KA	129	1875	UF	216	3125	ZR	328	4750
AS	45	650	KB	131	1900	UG	217	3150	ZS	331	4800
AT	47	675	KC	133	1925	UH	219	3175	ZT	335	4850
AU	48	700	KD	135	1950	UJ	221	3200	ZU	338	4900
AV	50	725	KE	136	1975	UK	223	3225	ZV	342	4950
BA	52	750	LA	138	2000	VA	224	3250	IA	345	5000
BB	54	775	LB	140	2025	VB	226	3275	IB	348	5050
BC	55	800	LC	142	2050	VC	228	3300	IC	352	5100
BD	57	825	LD	143	2075	VD	229	3325	ID	355	5150
BE	59	850	LE	145	2100	VE	231	3350	IE	359	5200
BF	60	875	MA	147	2125	VF	233	3375	IF	362	5250
BG	62	900	MB	148	2150	VG	235	3400	IG	366	5300
BH	64	925	MC	150	2175	VH	236	3425	IH	369	5350
BJ	66	950	MD	152	2200	VJ	238	3450	IJ	372	5400
BK	67	975	ME	154	2225	VK	240	3475	IK	376	5450
CA	69	1000	NA	155	2250	WA	242	3500	IL	379	5500
CB	71	1025	NB	157	2275	WB	243	3525	IM	383	5550
CC	72	1050	NC	159	2300	WC	245	3550	IN	386	5600
CD	74	1075	ND	160	2325	WD	247	3575	IP	390	5650
CE	76	1100	NE	162	2350	WE	248	3600	IQ	393	5700
DA	78	1125	PA	164	2375	WF	250	3625	IR	397	5750
DB	79	1150	PB	166	2400	WG	252	3650	IS	400	5800
DC	81	1175	PC	167	2425	WH	254	3675	IT	403	5850
DD	83	1200	PD	169	2450	WJ	255	3700	IU	407	5900
DE	85	1225	PE	171	2475	WK	257	3725	IV	410	5950
EA	86	1250	QA	172	2500	YA	259	3750	IW	414	6000
EB	88	1275	QB	174	2525	YB	260	3775			
EC	90	1300	QC	176	2550	YC	262	3800			
ED	91	1325	QD	178	2575	YD	264	3825			
EE	93	1350	QE	179	2600	YE	266	3850			
FA	95	1375	RA	181	2625	YF	267	3875			
FB	97	1400	RB	183	2650	YG	269	3900			
FC	98	1425	RC	185	2675	YH	271	3925			
FD	100	1450	RD	186	2700	YJ	272	3950			
FE	102	1475	RE	188	2725	YK	274	3975			

XA through XZ—Special

CF Relief Valve Pressure and CF Setting Code

For VFA and F1217
Flow Dividers

Use this chart to find the two-digit suffix code; the first digit corresponds to the nominal CF relief valve pressure setting, and the second digit corresponds to the nominal CF flow setting. Use Table 1 to find the first digit in the suffix code for both the VFA and F1217 valves. Use Table 2A to find the second digit in the suffix code of **VFA valves only**; use Table 2B to find the second digit in the suffix code of **F1217 valves only**.

Table 1: CF RV Setting

SUFFIX	BAR	PSI	SUFFIX	BAR	PSI
A	35	500	N	138	2000
B	43	625	O	147	2125
C	52	750	P	155	2250
D	60	875	Q	164	2375
E	69	1000	R	172	2500
F	78	1125	X	—	no relief valve
G	86	1250	2	—	2 relief valves
H	95	1375			
J	104	1500			
K	112	1625			
L	121	1750			
M	129	1875			

Table 2A: CF Flow (VFA)

SUFFIX	L/MIN	GPM
A	Adjustable	Adjustable
B	13.2, 14.0	3.5, 3.7
C	15.1	4
D	60.6	16
E	20.8	5.5
F	17	4.5
G	7.6	2
H	37.9	10
J	22.7	6
K	11.4	3
L	30.3	8
M	34.1	9
N	45.4	12
Q	18.9	5

Table 2B: CF Flow (F1217)

SUFFIX	L/MIN	GPM
A	Adjustable	Adjustable
B	15.1	4
C	18.9	5
D	22.7	6
E	75.7	20
F	11.4	3
G	13.2	3.5
H	113.6	30
J	132.5	35
K	53	14
R	56.8	15

This page left intentionally blank.

Eaton
Hydraulics Operations USA
14615 Lone Oak Road
Eden Prairie, MN 55344
USA
Tel: 952-937-9800
Fax: 952-294-7722
www.eaton.com/hydraulics

Eaton
Hydraulics Operations Europe
Route de la Longeraie 7
1110 Morges
Switzerland
Tel: +41 (0) 21 811 4600
Fax: +41 (0) 21 811 4601

Eaton
Hydraulics Operations Asia Pacific
11th Floor Hong Kong New World Tower
300 Huaihai Zhong Road
Shanghai 200021
China
Tel: 86-21-6387-9988
Fax: 86-21-6335-3912