

EATON

Vickers

**Servo-Performance Proportional
Directional Valves with Feedback**

Pressures to 315 bar (4500 psi)

KBSDG4V-5
1* Series

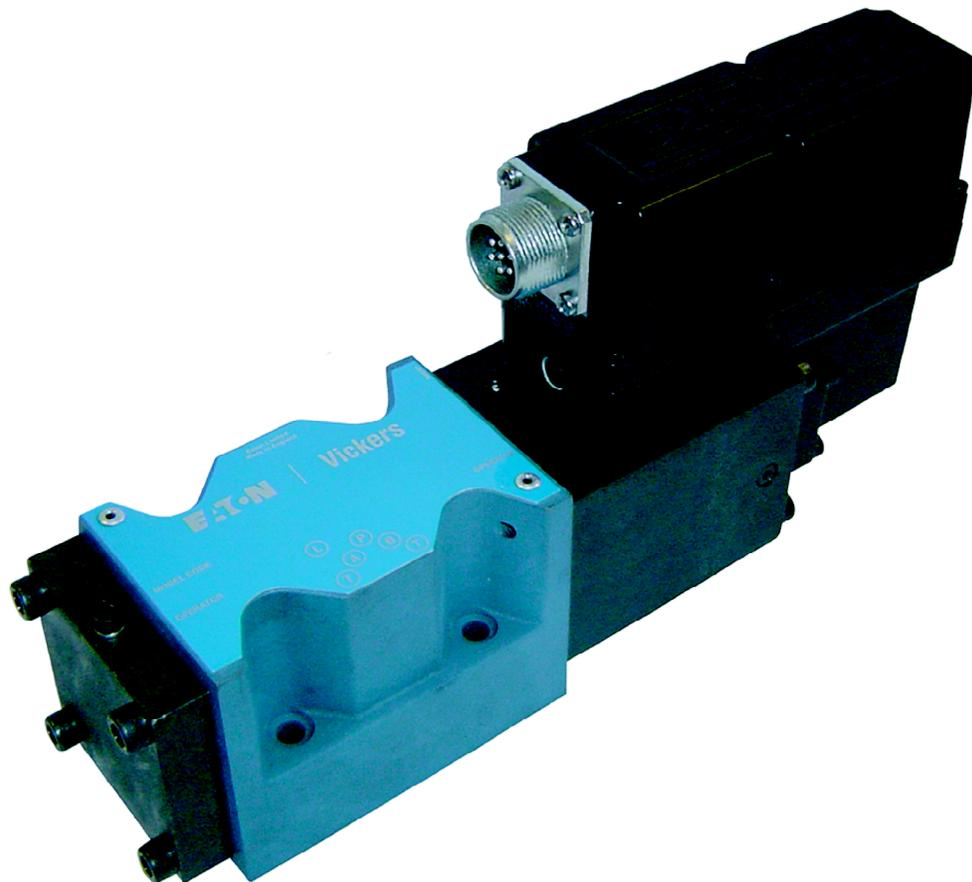

Contents

Introduction	
General Description	3
Features and Benefits	3
Typical Section View	3
Model Code	4
Spool Data	5
Functional Symbol	5
Operating Data	6
Pressures and Flow Rates	7
Performance Curves	
Flow Gain	8
Pressure Gain	8
Power Capacity Envelopes	8
Frequency Response	9
Installation Dimension	10
Subplates and Mounting Surfaces	11
Electrical Information	
Block Diagram Voltage Input M1	14
Block Diagram Current Input M2	15
Typical Connection Arrangements M1	16
Typical Connection Arrangements M2	17
Application Data	
Fluid Cleanliness	18
Hydraulic Fluids	18
Installation	18
Mounting Bolt Kits	18
Seal Kits	18
Electrical Connectors	18
Service Information	18

Introduction

General Description

The KBSDG4V-5 line offers a range of proportional directional valves with integral control electronics. Factory-set adjustments of gain and offset ensure consistent reproducibility valve-to-valve.

These four-way solenoid operated proportional valves have a high dynamic performance which enables them to be used in closed-loop applications, previously possible only with servo valves. Various spool options are available for rated flows up to 80 L/min (21 USgpm). Working pressures are to 315 bar (4500 psi). The spool position is monitored by an LVDT which feeds back information to the amplifier, enabling spool position to be accurately maintained.

This valve is available with an integral amplifier built directly on to the valve.

The only electrical inputs required are power supply (24V) and a command signal, either $\pm 10V$ or 4-20 mA (model code selectable). The amplifier is housed in a robust metal enclosure, sealed against ingress of water and other fluids. Electrical connections are via an industry standard 7-pin plug.

A spool position monitor pin allows the function of the valve to be electrically monitored. Ramp functions, if required, can be generated externally.

Features and Benefits

- Wide range of zero lap spool and flow rate options.
- Supported by a broad range of auxiliary function modules.
- Electronic feedback LVDT ensures accurate spool position control.
- Internal current feedback provides optimal control.
- Vibration and shock tested.
- Full CE electromagnetic compatibility.
- Factory-sealed adjustments ensure valve-to-valve reproducibility.
- Installation wiring reduced and simplified.
- Standard 7-pin connector.
- Standard 24V DC supply with wide tolerance band.
- Optional command signal, $\pm 10V$ or 4-20 mA (model code selectable).
- Valve with integrated amplifier selected, ordered, delivered and installed as one performance-tested package.
- Spool position monitor pin to help with troubleshooting.
- Simple valve removal and replacement for service (plug & play).
- IP67 valve, environmental protection rating.
- Optional valve enable function.

Typical Section View

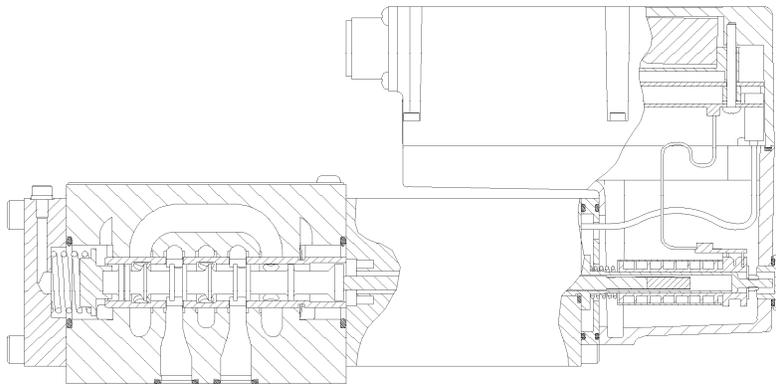

KBSDG4V-5

Model Code

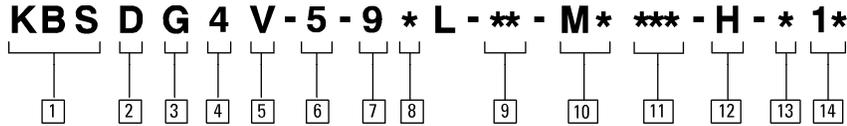

1 Valve type

KBS – Servo performance proportional valve with integral amplifier and electronic feedback

2 Control type

D – Directional valve

3 Mounting

G – Subplate mounted

4 Operation

4 – Solenoid operated

5 Pressure rating

V – 315 bar (4500 psi)

6 Interface

5 – ISO 4401, size 05-04-0-05 H6 model code

5 – ISO 4401, size 05-06-0-05 H7 model code

7 Spool type, center condition

9 – Zero underlap

8 Spool type, spring offset condition

2 – P,A,B,T blocked

6 – P blocked, A & B to tank

Note: 6 spool must be used in H6 configuration

9 Rated flow at 70 bar (1000 psi) loop Δp pressure drop

25 – 25 L/min (6.5 USgpm)

50 – 50 L/min (13.0 USgpm)

80 – 80 L/min (21.0 USgpm)

For actual maximum flow refer to Power capacity envelope curves, page 8-9.

10 Command Signal

M1 – ±10V voltage command signal

M2 – 4-20 mA current command signal

11 Electrical connection

PC7 – 7 pin connector without plug

PE7 – 7 pin connector with plug

PH7 – As PE7 but with pin “C” used for enable signal

PR7 – As PC7 but with pin “C” used for enable signal

12 Electrical power

H – 24V DC amplifier supply

13 Port T pressure limit code

6 – 160 bar

7 – 210 bar

14 Design number

1* series. Subject to change



WARNING

Valves with integral amplifiers are supplied with or without the metal 7-pin plug. The Vickers™ plug, part no. 934939, must be correctly fitted to ensure that the EMC rating and IP67

rating are achieved. The plug retaining nut must be tightened with a torque of 2,0-2,5 Nm (1.5-2.0 lbf ft), and the cable clamp (cable outside diameter range, 8,0-10,5 mm (0.31-0.41 inches) tightened as required to effect a proper seal.

Spool Data

Spool Symbols

Functional Symbol

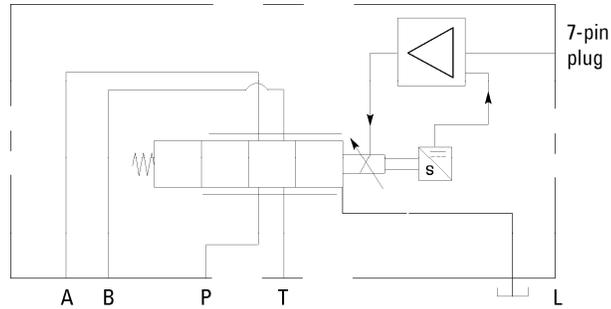

Model Types KBSDG4V-5

proportional directional valve (with integral electronics)

Spool Types and Flow Ratings

Symmetric Spools

Base line pressure drop $\Delta p = 35$ bar (500 psi) per metering flow path, e.g. B to T. For actual maximum flow refer to power capacity envelope curves.

Spool code	Spool symbol	Flow rating
For KBSDG4V-5 valves:		
92L25	92L	25 L/min (6.5 USgpm)
92L50	92L	50 L/min (13 USgpm)
92L80	92L	80 L/min (21 USgpm)
96L25	96L	25 L/min (6.5 USgpm)
96L50	96L	50 L/min (13 USgpm)
96L80	96L	80 L/min (21 USgpm)

Available Spools for KBSDG4V-5

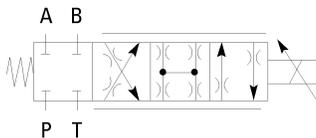

Spool type 92L

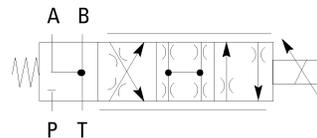

Spool type 96L

Operating Data

Data is typical, with fluid at 36 cST (168 SUS) and 50°C (122°F)

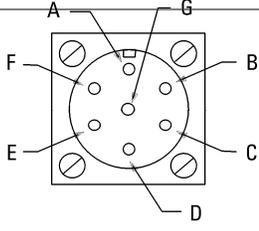
Power supply	24V DC (21V to 36V including 10% peak-to-peak max ripple) max current 3,7A																		
Command signal																			
Voltage mode	0 to 10V DC, or 0 to -10V DC, or -10V to +10V DC																		
Input impedance	47 kΩ																		
Common mode voltage to pin D	18V (max)																		
Current mode	4-20 mA																		
Max differential voltage to pin E to pin B	100 mV																		
Input impedance for current mode	100Ω																		
Valve enable signal for model code PH7 & PR7																			
Enable	>8.5V (36V max)																		
Disable	<6.5V																		
Input impedance	10 kΩ																		
7-pin plug connector	 <table border="1" style="display: inline-table; vertical-align: top;"> <thead> <tr> <th>Pin</th> <th>Description</th> </tr> </thead> <tbody> <tr> <td>A</td> <td>Power supply positive (+)</td> </tr> <tr> <td>B</td> <td>Power supply 0V and current command return</td> </tr> <tr> <td>C</td> <td>Not connected (PE7 & PC7)</td> </tr> <tr> <td>C</td> <td>Valve enable (PH7 & PR7)</td> </tr> <tr> <td>D</td> <td>Command signal (+V or current in)</td> </tr> <tr> <td>E</td> <td>Command signal (-V or current GND)</td> </tr> <tr> <td>F</td> <td>Output monitor</td> </tr> <tr> <td>G</td> <td>Protective ground</td> </tr> </tbody> </table>	Pin	Description	A	Power supply positive (+)	B	Power supply 0V and current command return	C	Not connected (PE7 & PC7)	C	Valve enable (PH7 & PR7)	D	Command signal (+V or current in)	E	Command signal (-V or current GND)	F	Output monitor	G	Protective ground
Pin	Description																		
A	Power supply positive (+)																		
B	Power supply 0V and current command return																		
C	Not connected (PE7 & PC7)																		
C	Valve enable (PH7 & PR7)																		
D	Command signal (+V or current in)																		
E	Command signal (-V or current GND)																		
F	Output monitor																		
G	Protective ground																		
View of pins of fixed half.																			
Electromagnetic compatibility (EMC):	IEC61326-2-1																		
Zero adjustment	±18% mechanical adjustment accessible under plug in LVDT																		
Monitor points signal																			
Voltage mode	±10V DC for full stroke																		
Output impedance	10 kΩ																		
Power stage PWM frequency	10 kHz nominal																		
Reproducibility, valve-to-valve (at factory settings):																			
Flow gain at 100% command signal	≤5%																		
Protection:																			
Electrical	Reverse polarity protected																		
Mechanical	IEC 144, Class IP67																		
Ambient air temperature range for full performance	0°C to 70°C (32°F to 158°F)																		
Oil temperature range for full performance	0°C to 70°C (32°F to 158°F)																		
Minimum temperature at which valves will work at reduced performance	-20°C (-4°F)																		
Storage temperature range	-25°C to +85°C (-13°F to +185°F)																		
Continued on next page																			

Operating Data

Continued from previous page

Supporting products:	
Auxiliary electronic modules (DIN-rail mounting):	
EHA-CON-201-A2* signal converter	See catalog GB 2410A
EHD-DSG-201-A-1* command signal generator	See catalog GB 2470
EHA-RMP-201-A-2* ramp generator	See catalog GB 2410A
EHA-PID-201-A-2* PID controller	See catalog GB 2427
EHA-PSU-201-A-10 power supply	See catalog GB 2410A
Relative duty factor	Continuous rating (ED = 100%)
Hysteresis	<0.5%
Step response:	
Step size (% of max spool stroke):	Time to reach 90% of required step:
0 to 100%	32 mS
100 to 0%	13 mS
10 to 90%	27 mS
90 to 10%	10 mS
±10 to ±10%	22 mS
±25 to ±25%	30 mS
Mass: KBSDG4V-5	5,9 kg (13 lb) approx.

Pressures and Flow Rates H7 Option only

Maximum pressures, bar (psi)

Port L condition	Ports P, A, B	T	L
Normally blocked by mounting surface	315 (4500)	160 (2300)	160 (2300)
Drained directly to tank	315 (4500)	210 (3000)	10 (145)

Performance Curves

Flow Gain

Flow from port P-A-B-T or P-B-A-T at 70 bar (1000 psi) total valve Δp (35 bar (500 psi) per metering edge)

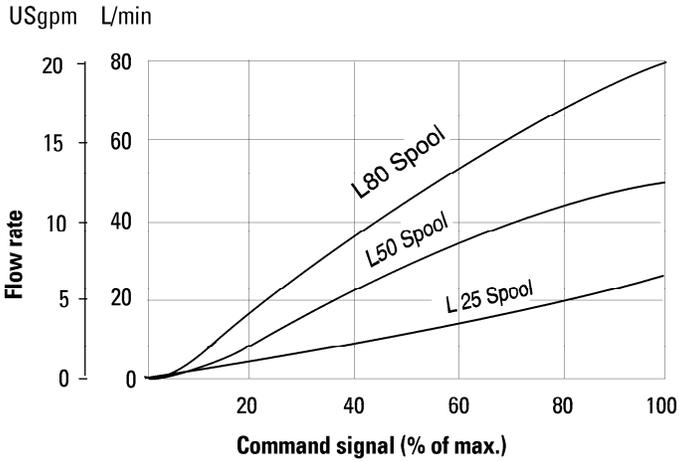

Pressure Gain

Δp between ports A and B or B and A, as % of port P pressure

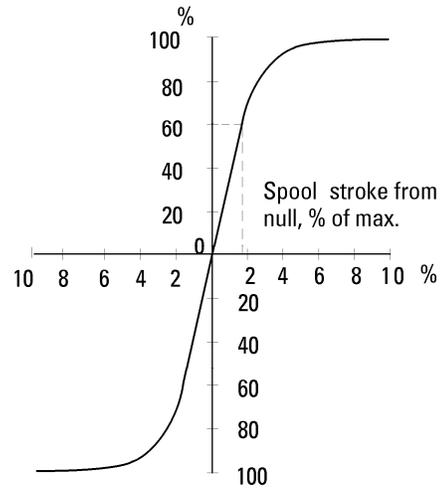

Power Capacity Envelopes

KBSDG4V-5-9*L25

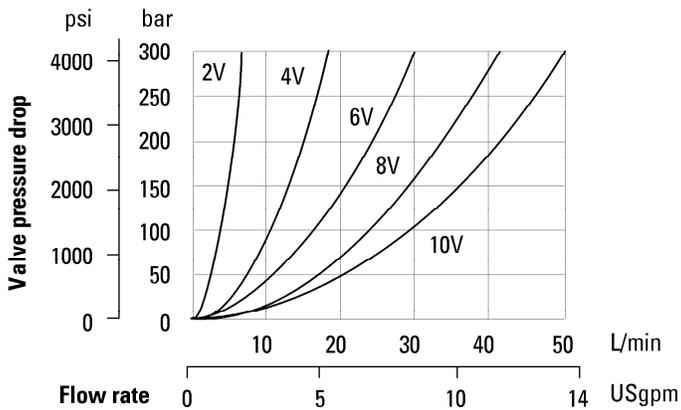

At other pressure drop (Δp) values, flow rates Q_x approximate to:

$$Q_x = Q_D \sqrt{\frac{\Delta p_x}{\Delta p_D}}$$

where Q_D = Datum flow rate
 Δp_D = Pressure drop at datum flow rate
 Δp_x = Required Δp

Limited by valve capacity. Refer to Power Capacity envelope.

Performance Curves

Power Capacity Envelopes

KBSDG4V-5-9*L50

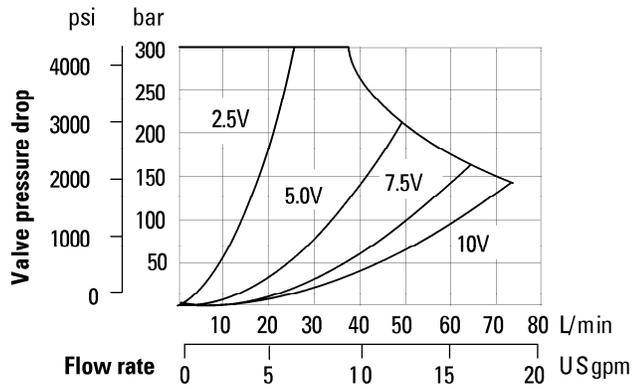

KBSDG4V-5-9*L80

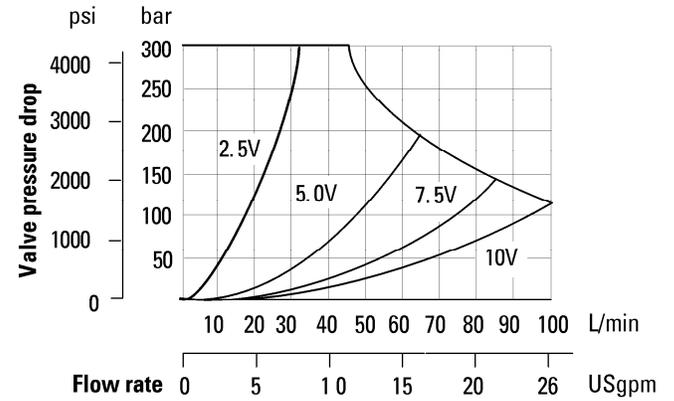

Frequency Response, typical

For amplitudes of $\pm 5\%$, $\pm 10\%$, $\pm 25\%$ with zero offset.
 Δp (P to T) = 70 bar (1000 psi)

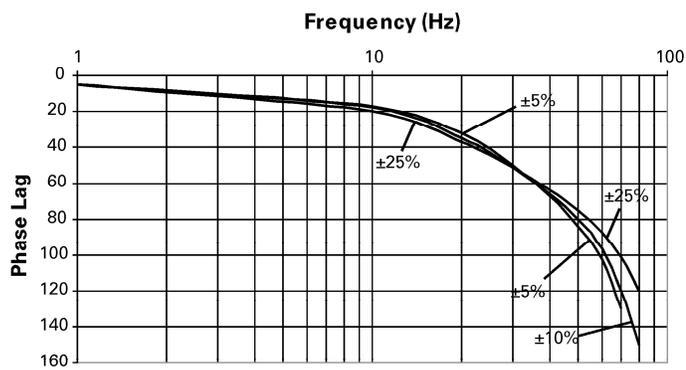

Frequency Response

Looped flow at 70 bar valve pressure drop
 Amplitudes based on % of rated flow

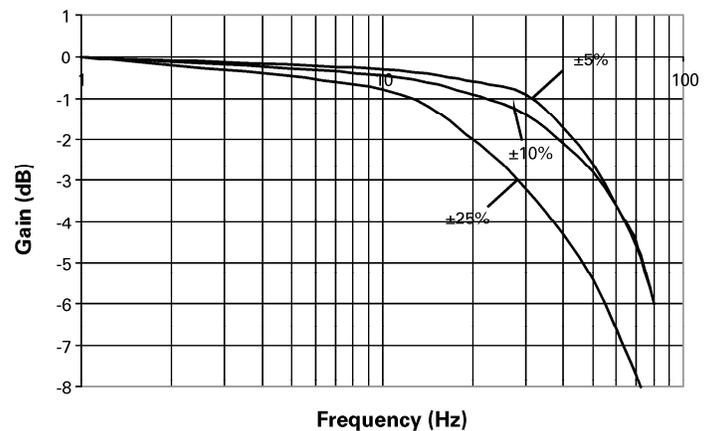

Installation Dimensions

mm (inch)

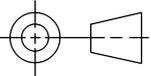
3rd angle projection 

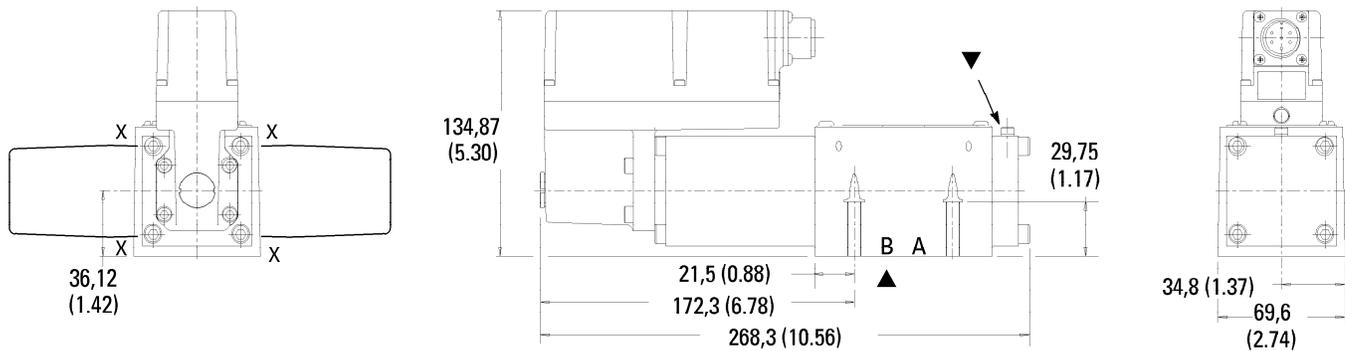

Amplifier and solenoid assembly may be rotated 90° as shown by removing 4 screws shown X.
Re-torque to 13-15 Nm (10-11 lbf ft)

▲ Mounting surface seals supplied. For mounting surface dimensions and subplate options see page 8.

▼ Bleed screw locations
Air bleed, socket head cap screw
Torque to 2,5-3,0 Nm (2.0-2.5 lbf ft)



WARNING

Valves with integral amplifiers are supplied with or without the metal 7-pin plug. The Vickers™ plug, part no. 934939, must be

correctly fitted to ensure that the EMC rating and IP67 rating are achieved. The plug retaining nut must be tightened with a torque of 2,0-2,5 Nm (1.5-2.0 lbf ft) to effect a proper seal.

Subplates and Mounting Surfaces

General Description

When a subplate is not used, amachined pad must be provided for valve mounting. Pad must be flat within 0,0127 mm (.0005 inch) and smooth within 1,6 µm (63 microinch). Mounting bolts, when provided by customer, should be ISO 898 class 12.9 or better.

Dimensional Tolerances

Dimensional tolerance on interface drawings is ±0,2 mm (±0.008") except where otherwise stated. ISO 4401 specifies inch conversion to ±0.01".

Conversion from Metric

ISO 4401 gives dimensions in mm. Inch conversions are accurate to 0.01" unless otherwise stated.

Mounting Bolt Tappings

ISO 4401 gives metric thread tappings. Alternate UNC tappings are Eaton recommendations that allow

these plates and associated valves to be used up to their maximum pressures, when using Eaton recommended bolt kits, or bolts of an equivalent strength. It is recommended that Customer's own manifold blocks for UNC bolts should be tapped to the minimum depths given in the footnotes.

Installation Dimensions

Subplates with Rear Ports P, T, A, B, Maximum Pressure 210 bar (3000 psi)

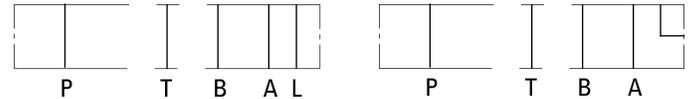

Model type KD GSM-5-676805-2* (with rear port L)

Model type EKD GSM-01Y-1*-R (with side port L)

Rear port L, KD GSM-5-676805 only:

G 1/8" (1/8" BSPF) x 12,0 (0.47) full thread depth

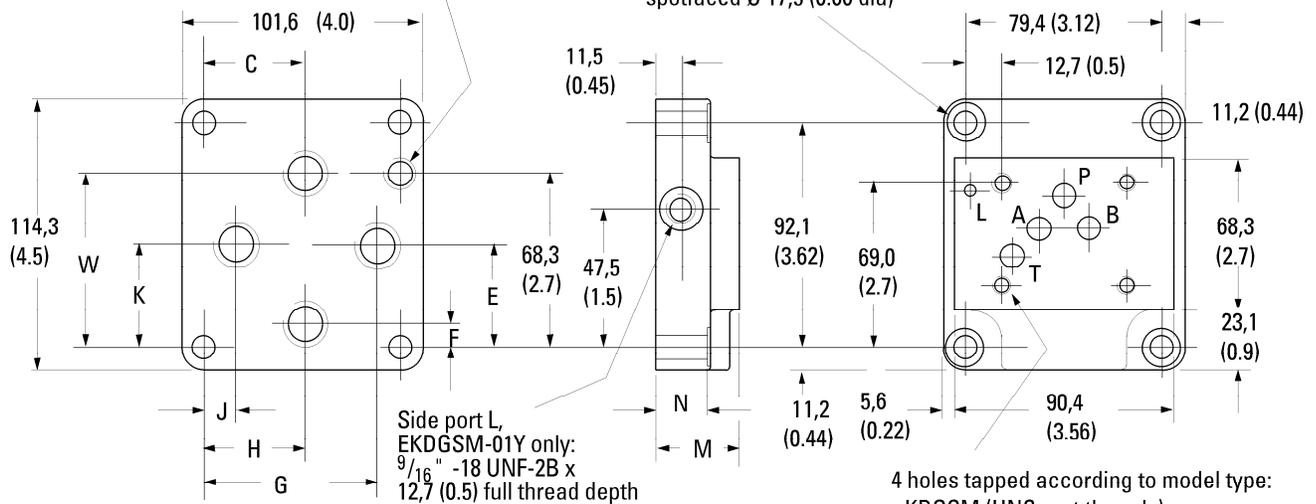

Mass = 1,3 kg (2.9 lbs)

4 holes tapped according to model type:

- KD GSM (UNC port threads) 1/4"-20 UNC-2B x 12,7 (0.5) deep
- EKD GSM (BSPF port threads) M6 x 15,8 (0.62) deep

Model

210 bar (3000 psi) KD GSM-5-676805-2

280 bar (4000 psi) EKD GSM-01Y-10-R

Ports P, T, A, B Threads

3/4" -16 UNF-2B x 14,0 (0.56) full thread depth

G 1/2 (1/2" BSPF) x 15,0 90.59 full thread depth

Dimensions Model

	C	E	F	G	H	J	K	M	N	W
210 bar (3000 psi) KD GSM-5-676805-2	45,2 (1.78)	42,1 (1.66)	19,0 (0.75)	68,3 (2.69)	45,2 (1.78)	23,8 (0.94)	42,1 (1.66)	31,8 (1.25)	23,8 (0.94)	57,1 (2.25)
280 bar (4000 psi) EKD GSM-01Y-10-R	39,7 (1.56)	40,5 (1.59)	9,9 (0.39)	70,6 (2.78)	39,7 (1.56)	10,7 (0.42)	40,5 (1.59)	36,5 (1.44)	28,6 (1.13)	72,6 (2.86)

Subplates and Mounting Surfaces

Installation Dimensions

Subplates with Rear Ports P, T, A, B, L, Maximum Pressure 315 bar (4500 psi)

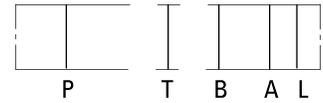

Model types:
 KD GSM-5-615225-1*
 KD GSM-5-615226-1*

All dimensions in mm (inches)

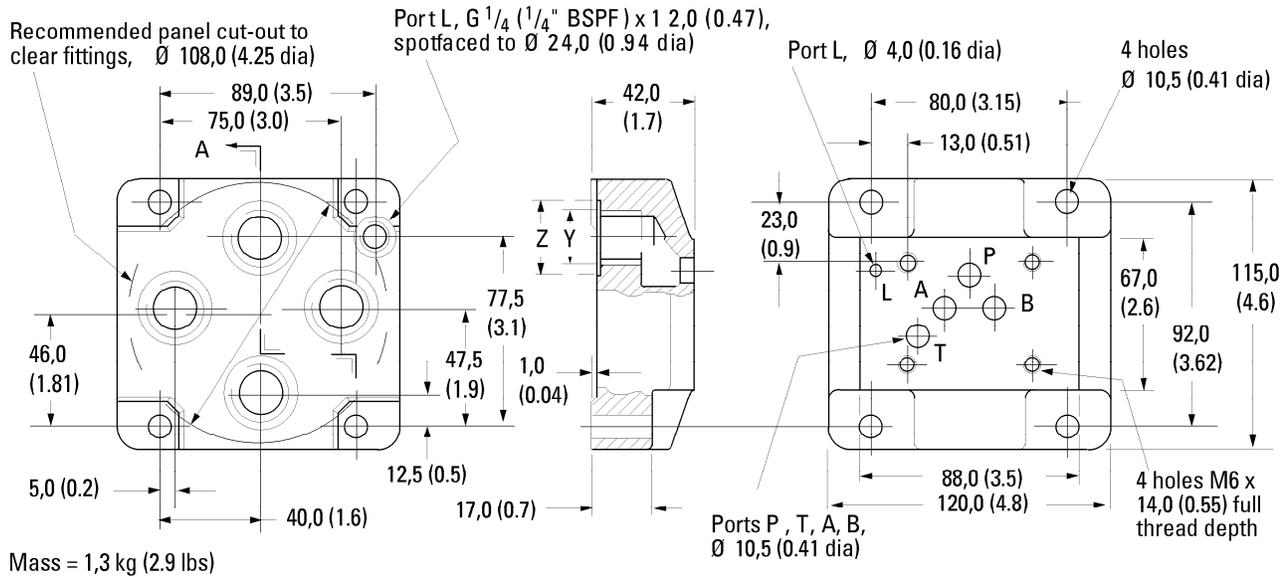

Ports P, T, A, B

Model	Y Thread	Z diameter
KD GSM-5-615225-10	G1/2 (1/2" BSPF) x 14,0 (0.55) full thread depth	30,0 (1.18)
KD GSM-5-615226-10	G3/4 (3/4" BSPF) X 16,0 (0.63) full thread depth	33,0 (1.30)

Mounting Surfaces

Mounting Surface Interface to ISO 4401 (Size 05)

This interface conforms to:
ISO 4401-05-04-0-05
ANSI/B93.7M (and NFPA)
size 05
CETOP R35H4.2-05
DIN 24340 Form A10

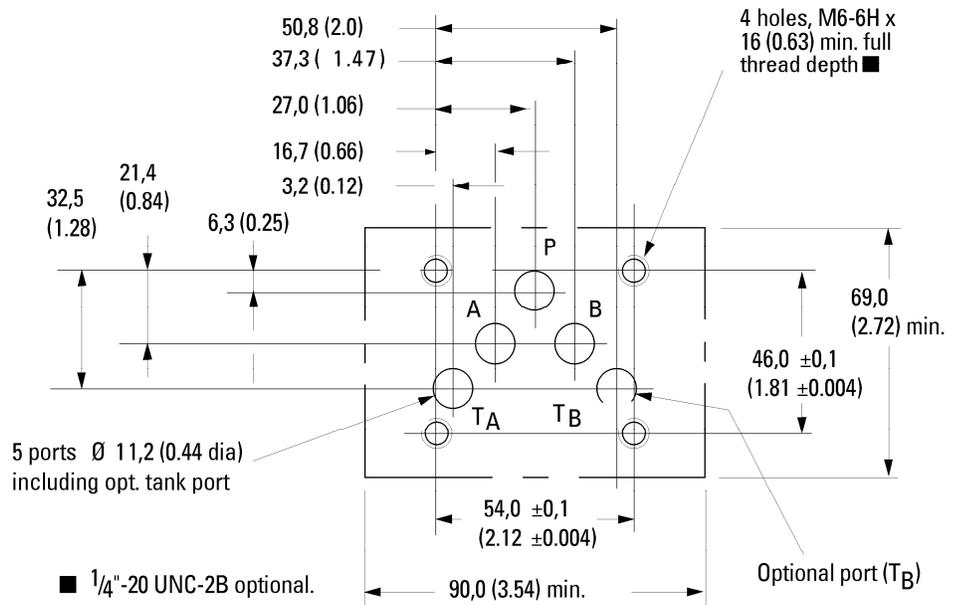

Interface with Additional Drain Port

The interface conforms to:
ISO 4401-05-06-0-05, plus
hole "L"

Typically used for
proportional and other valves
requiring an additional drain
port.

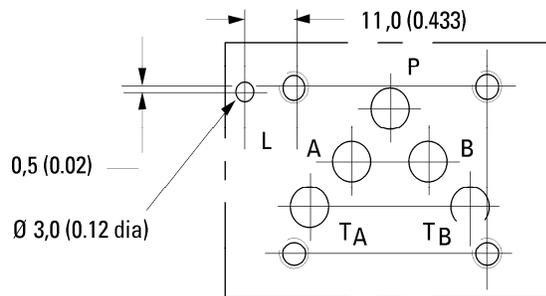

Electrical Information

Block Diagram Voltage Input (M1) KBSDG4V-5

KBSDG4V-5 Wiring

Connections must be made via the 7-pin plug mounted on the amplifier. See page 16-17 of this leaflet and Eaton's Installation Wiring Practices for Vickers™ Electronic Products, leaflet 2468. Recommended cable sizes are shown below:

Power cables:

For 24V supply

0,75 mm² (18 AWG) up to 20m (65 ft)

1,00 mm² (16 AWG) up to 40m (130 ft)

Signal cables:

0,50 mm² (20 AWG)

Screen (shield):

A suitable cable would have 7 cores, a separate screen for the signal wires and an overall screen.

Cable outside diameter 8,0–10,5 mm (0.31–0.41 inches)

See connection diagram on page 16.

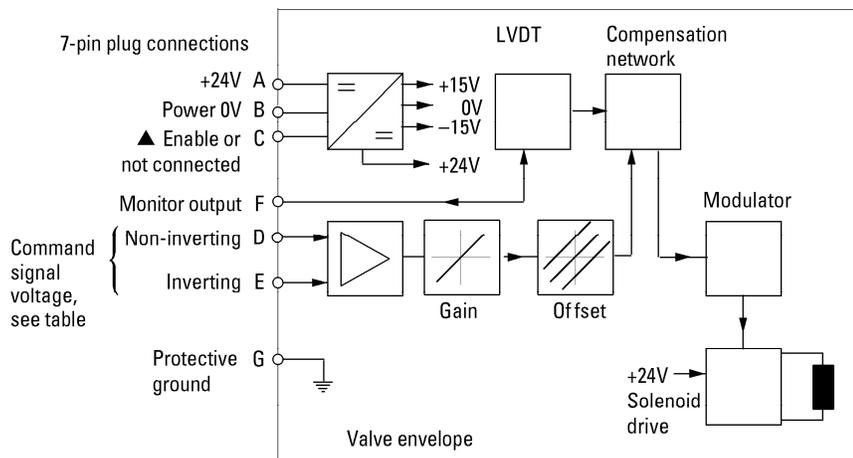

▲ Pin C is used for a valve enable signal with electrical connections PH7 and PR7.

Command Signals and Outputs, M1

7-pin plug		Flow direction
Pin D	Pin E	
Positive	0V	P to A
0V	Negative	
$U_D - U_E = \text{Positive}$		
Negative	0V	P to B
0V	Positive	
$U_D - U_E = \text{Negative}$		



WARNING

All power must be switched off before connecting or disconnecting any plugs.

Electrical Information

Block Diagram Current Input (M2) KBSDG4V-5

KBSDG4V-5 Wiring

Connections must be made via the 7-pin plug mounted on the amplifier. See page 16-17 of this leaflet and Eaton's Installation Wiring Practices for Vickers™ Electronic Products, leaflet 2468. Recommended cable sizes are shown below:

Power cables:

For 24V supply
 0,75 mm² (18 AWG) up to 20m (65 ft)
 1,00 mm² (16 AWG) up to 40m (130 ft)

Signal cables:

0,50 mm² (20 AWG)

Screen (shield):

A suitable cable would have 7 cores, a separate screen for the signal wires and an overall screen.

Cable outside diameter
 8,0–10,5 mm (0.31–0.41 inches)

See connection diagram on page 17.

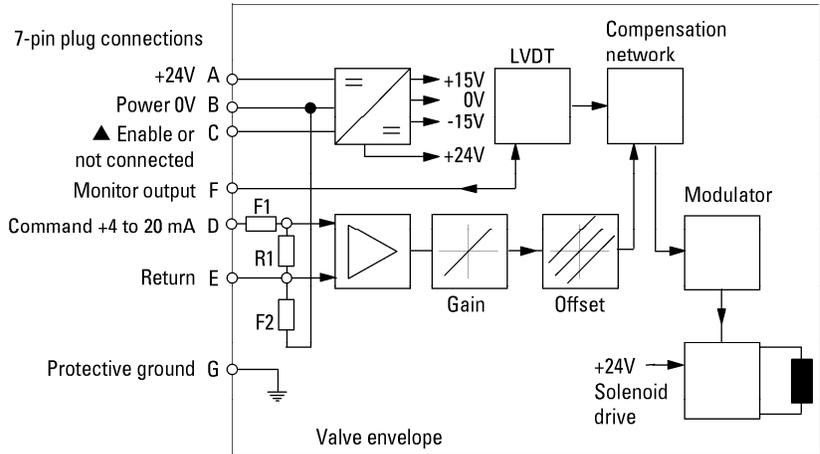

▲ Pin C is used for a valve enable signal with electrical connections PH7 and PR7.

R1 shunt resistor 100R

F1, F2 resettable fuse

Command Signals and Outputs, M2

7-pin plug			
Pin D	Pin E	Pin B	Flow direction
More than 12 mA	Current return	Power ground	P to A
Less than 12 mA	Current return	Power ground	P to B



WARNING

All power must be switched off before connecting/disconnecting any plugs.

Electrical Information

Wiring Connections Voltage Input (M1)

■ Spool position monitor voltage (pin F) will be referenced to the KB valve local ground.



WARNING

Do not ground pin C.

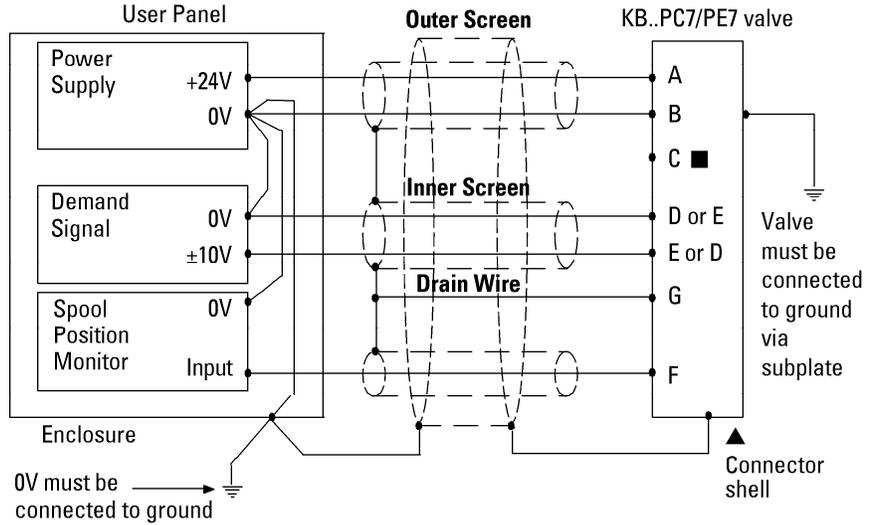

Wiring Connections for M1 Valves with Enable Feature

▲ Note: In applications where the valve must conform to European RFI/EMC regulations, the outer screen (shield) must be connected to the outer shell of the 7 pin connector, and the valve body must be fastened to the earth ground. Proper earth grounding practices must be observed in this case, as any differences in command source and valve ground potentials will result in a screen (shield) ground loop.

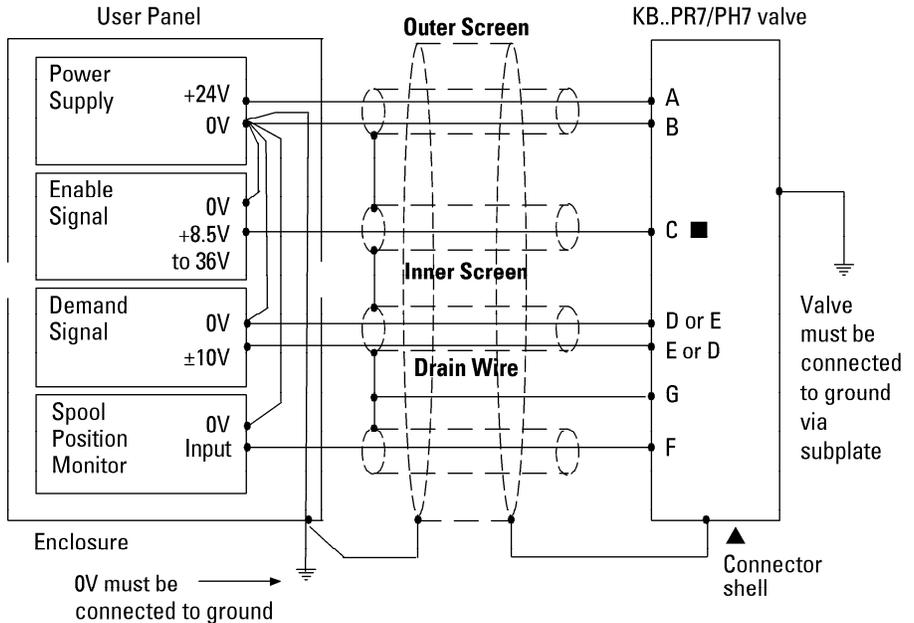

Electrical Information

Wiring Connections Current Input (M2)

■ Spool position monitor voltage (pin F) will be referenced to the KB valve local ground.



WARNING
Do not ground pin C.

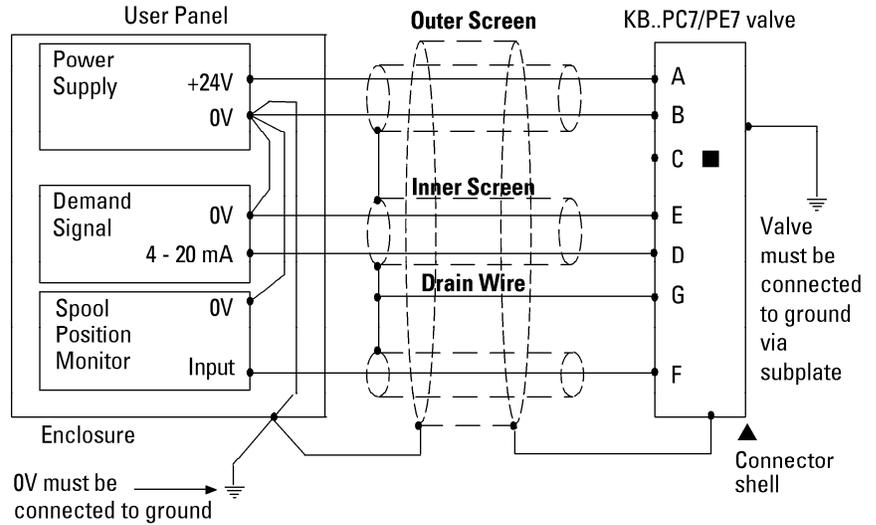

Wiring Connections for M2 Valves with Enable Feature

▲ Note: In applications where the valve must conform to European RFI/EMC regulations, the outer screen (shield) must be connected to the outer shell of the 7 pin connector, and the valve body must be fastened to the earth ground. Proper earth grounding practices must be observed in this case, as any differences in command source and valve ground potentials will result in a screen (shield) ground loop.

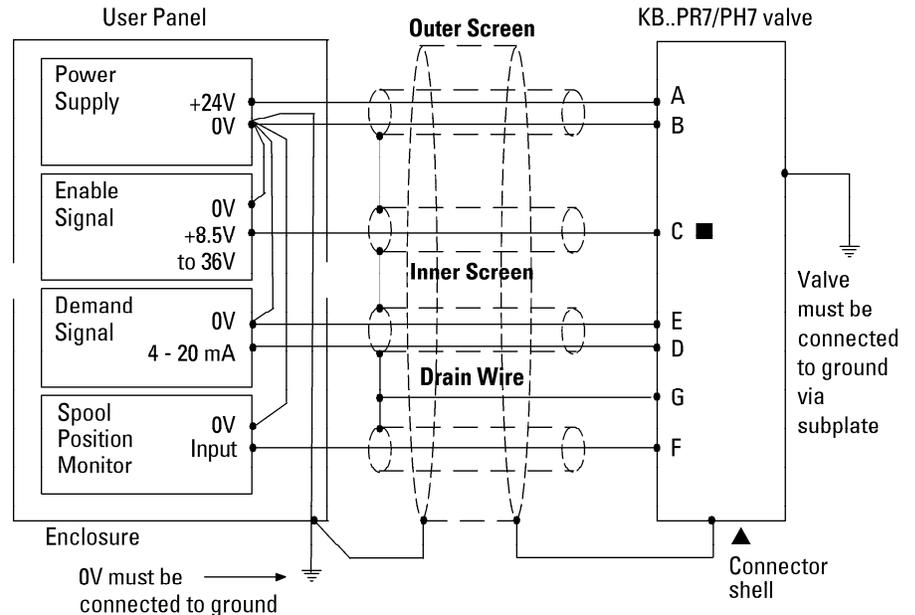

WARNING
Electromagnetic Compatibility (EMC)

It is necessary to ensure that the valve is wired up as above. For effective protection the user electrical cabinet, the valve subplate or manifold and the cable

screens should be connected to efficient ground points. The metal 7 pin connector part no. 934939 should be used for the integral amplifier.

In all cases both valve and cable should be kept as far away as possible from any sources of electromagnetic

radiation such as cables carrying heavy current, relays and certain kinds of portable radio transmitters, etc. Difficult environments could mean that extra screening may be necessary to avoid the interference.

It is important to connect the 0V lines as shown above.

The multi-core cable should have at least two screens to separate the demand signal and monitor output from the power lines.

The enable line to pin C should be outside the screen which contains the demand signal cables.

Application Data

Fluid Cleanliness

Proper fluid condition is essential for long and satisfactory life of hydraulic components and systems. Hydraulic fluid must have the correct balance of cleanliness, materials and additives for protection against wear of components, elevated viscosity and inclusion of air.

Recommendations on contamination control methods and the selection of products to control fluid condition are included in Eaton's publication 9132 or 561, "Vickers™ Guide to Systemic Contamination Control". The book also includes information on the Eaton concept of "ProActive Maintenance". The following recommendations are based on ISO cleanliness levels at 2 µm, 5 µm and 15 µm.

For products in this catalog the recommended levels are:

0 to 70 bar (1000 psi):
18/16/13

70+ bar (1000 + psi):
17/15/12

Eaton products, as any components, will operate with apparent satisfaction in fluids with higher cleanliness codes than those described. Other manufacturers will often recommend levels above those specified.

Experience has shown, however, that life of any hydraulic components is shortened in fluids with higher cleanliness codes than those listed above. These codes have been proven to provide a long trouble-free service life for the products shown, regardless of the manufacturer.

Hydraulic Fluids

Materials and seals used in these valves are compatible with antiwear hydraulic oils, and non-alkyl-based phosphate esters. The extreme operating viscosity range is 500 to 13 cSt (2270 to 70 SUS) but the recommended running range is 54 to 13 cSt (245 to 70 SUS).

Installation

The proportional valves in this catalog can be mounted in any attitude, but it may be necessary in certain demanding applications, to ensure that the solenoids are kept full of hydraulic fluid. Good installation practice dictates that the tank port and any drain port are piped so as to keep the valves full of fluid once the system start-up has been completed.

Mounting Bolt Kits

For KBSDG4V-5

BKDG01633M (metric)

BKDPNG40706 (inch)

If not using Eaton recommended bolt kits, bolts used should be to ISO 898, 12.9 or better.

Seal Kits

KBSDG4V-502-332751

Electrical Connectors

KBSDG4V

7-pin plug (metal)934939

7-pin plug (plastic)694534

(metal plug must be used for full EMC protection)

Service Information

The products from this range are preset at the factory for optimum performance; disassembling critical items would destroy these settings. It is therefore recommended that should any mechanical or electronic repair be necessary they should be returned to the nearest Eaton repair center. The products will be refurbished as necessary and retested to specification before return.

Field repair is restricted to the replacement of the seals.

Note:

The feedback/solenoid assembly installed in this valve should not be disassembled.

Typical Part Numbers and Model Codes

5996524-001	KBSDG4V-5-92L-50-M1-PE7-H7-11	5996528-001	KBSDG4V-5-96L-50-M1-PE7-H7-11
5996525-001	KBSDG4V-5-92L-80-M1-PC7-H7-11	5996533-001	KBSDG4V-5-96L-50-M2-PE7-H7-11
5996526-001	KBSDG4V-5-92L-80-M1-PE7-H7-11	5996529-001	KBSDG4V-5-96L-80-M1-PC7-H7-11
5996527-001	KBSDG4V-5-92L-80-M1-PH7-H7-11	5996530-001	KBSDG4V-5-96L-80-M1-PE7-H7-11
5996532-001	KBSDG4V-5-92L-80-M2-PE7-H7-11	5996531-001	KBSDG4V-5-96L-80-M1-PH7-H7-11

Eaton
Hydraulics Operations USA
14615 Lone Oak Road
Eden Prairie, MN 55344
USA
Tel: +1 952 937 9800
Fax: +1 952 294 7722
www.hydraulics.eaton.com

Eaton
Hydraulics Operations Europe
Route de la Longeraie 7
1110 Morges
Switzerland
Tel: +41 21 811 4600
Fax: +41 21 811 4601

Eaton
Hydraulics Operations Asia Pacific
11th Floor Hong Kong New World Tower
300 Huaihai Zhong Road
Shanghai 200021
China
Tel: +86 21 6387 9988
Fax: +86 21 6335 3912



© 2007 Eaton Corporation
All Rights Reserved
Printed in USA
Document No. V-VLPO-MC006-E
Supersedes 5071.03/EN/1097/A
August 2008