

EATON

Vickers

Proportional Pressure Relief Valves

Technical Catalog

KBCG-3-1*



Contents

General Description	Page 3
Functional Symbol	Page 3
Typical Section	Page 3
Model Codes	Page 4
Operating Data	Page 5
Performance Data	Page 7
Installation Dimensions	Page 8
Electrical Information	
Block Diagram	Page 9
Typical Connection Arrangements	Page 10
Further Information	Page 11



This product has been designed and tested to meet specific standards outlined in the European Electromagnetic Compatibility Directive (EMC) 89/336/EEC, amended by 91/263/EEC, 92/31/EEC and 93/68/EEC, article 5. For instructions on installation requirements to achieve effective protection levels, see this leaflet and the Installation Wiring Practices for Vickers™ Electronic Products leaflet 2468. Wiring practices relevant to this Directive are indicated by  Electromagnetic Compatibility (EMC).

General Description

An electro-hydraulic proportional relief valve designed to regulate pressure in a hydraulic system in proportion to an applied electrical input.

These open-loop, single-stage valves can be used for direct control of pressure in low flow systems, or for pilot control of larger pressure controls, and for such applications as pressure-controlled pumps.

The integral amplifier allows the pressure to be controlled from a low power command signal: either a voltage or current command. The amplifier is mounted in a robust metal housing and electrical connections are via an industry standard 7-pin plug. Factory-set adjustments ensure high reproducibility valve-to-valve.

Other Models

For proportional pressure relief valves with flow ratings up to 400 L/min (106 USgpm), see catalog V-VLPO-MC003-E (model types KBCG, sizes 6 and 8).

Features and Benefits

- Valve design ensures low hysteresis and good repeatability.

- Self-bleeding design simplifies installation and ensures consistent performance.
- When used for piloting a large pressure relief or reducing valve, a low minimum pressure is obtainable, combined with fast and stable response to step input signals.
- On-board ramp adjustment

Functional Symbol

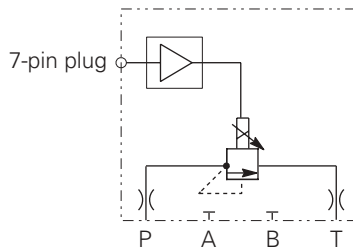

Typical Section

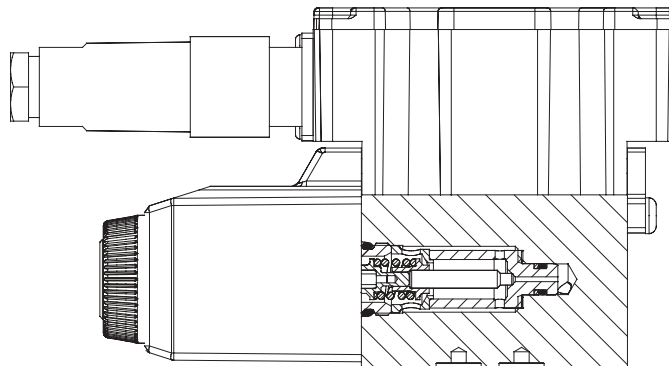

Model Codes

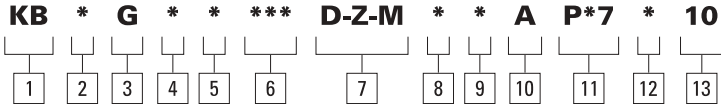

1 Valve Type
 KB - Proportional valve with integral amplifier, B series

2 Type
 C - Pressure relief

3 Mounting
 G - Subplate mounted

4 Interface
 3 - ISO 4401, size 3 (NFPA D03)

5 Build Orientation
 Blank - Right hand (standard)
 L - Left hand

6 Controlled Pressure Range
 At rated flow of 1 L/min (0.26 USgpm)
 40 - 2-40 bar (29-580 psi)
 100 - 3-100 bar (44-1450 psi)
 160 - 4-160 bar (58-2300 psi)
 250 - 5-250 bar (73-3625 psi)
 350 - 6-350 bar (87-5000 psi)

7 Standard Features
 DZM - for KBCG3

8 Electrical Command Options
 1 - +/- 10 volts control signal
 2 - 4-20 mA control signal

9 Ramp Options
 1 - No ramp
 2 - Standard ramp (typically 65 ms)
 3 - Long ramp (typically 80 ms)

10 Command/Pressure Characteristic
 A - Standard

11 Electrical Connection
 PC7 - 7 pin connector, without plug supplied
 PE7 - 7 pin connector, with plug supplied
 PH7 - As PE7 but with pin 'C' used for enable signal
 PR7 - as PC7 but with pin 'C' used for enable signal

12 Coil Rating
 H1 - 24V DC amplifier supply

13 Design Number, 1* Series
 Subject to change. Installation dimensions unaltered for design numbers 10 to 19 inclusive.



Warning

To conform to the EC Electromagnetic Compatibility directive (EMC) this KBCG valve must be fitted with a metal 7-pin plug. The screen of the cable must be securely connected to the shell of the metal connector. A suitable IP67 rated connector is available from Eaton, part no. 934939. Alternatively a non IP67 rated connector is available from ITT-Cannon, part no. CA 02 COM-E 14S A7 P.

Operating Data

Standard test conditions are with antiwear hydraulic oil at 36 cSt (168 SUS) and 40°C (104°F)

Maximum pressures:

Port P:

Operating

See **6** in "Model Code"

Static

350 bar (5075 psi)

Port T:

Operating

2 bar (29 psi). See "Back pressure at port T" under "Installation and start-up" below.

Static

210 bar (3000 psi)

Flow limits:

Rated flow

1 L/min (0.26 USgpm)

Maximum flow

5 L/min (1.3 USgpm)

Coil or amplifier rating

24V x 40W max. (22 to 36V including 10% pk.-to-pk. max. ripple)

Command signal:

Volts (see model code **8** - 1)

0 to +10V or 0 to -10V

Input impedance

47 kΩ

Common mode voltage to pin B

4V

Current (see model code **8** - 2)

4 to 20 mA

Input impedance

100Ω

Valve enable signal:

Enable

>9.0V (36V max)

Disable

<2.0V

Input impedance

36 kΩ

7-pin plug connector

Pin Description

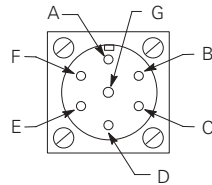

A Power supply positive (+)

B Power supply 0V and current command return

C Valve enable (PH7 & PR7)

D Command signal (+V or current in)

E Command signal (-V or current GND)

F Output monitor

G Protective ground

View of pins of fixed half

Electromagnetic compatibility (EMC):

Emission (10 V/m)

EN 50081-2

Immunity (10 V/m)

EN 50082-2

Monitor signal (pin F)

1.7 V/amp solenoid current

Output impedance

10 kΩ

Pressure gain

See graph

Factory setting - Maximum with 100% command signal.

Pressure override

See graph

Pressure step response

Typical times to reach 90% of commanded step:

(20 cm³ volume, 1 L/min (0.26 USgpm)):

Model code **9**:

KBCG-3-250 model:

1	2	3
---	---	---

0 to 100% step

60 ms	65 ms	87 ms
-------	-------	-------

100 to 0% step

48 ms	55 ms	73 ms
-------	-------	-------

Linearity, between 10% and 100% of controlled pressure range

<4%

Hysteresis

<5% (with factory-set dither)

Repeatability

<+/-1.0% of rated pressure

Reproducibility, valve-to-valve (at factory settings):

Pressure at 100% command signal

≤5%

Operating Data (continued)

Protection:	
Electrical	Reverse polarity protected
Environmental	IEC 529, Class IP67
Mass	2,2 kg (4.85 lb)
Supporting products:	
Auxiliary electronic modules (DIN-rail mounting):	
EHA-CON-201-A-2* Signal converter	See catalog 2410B
EHD-DSG-201-A-1* Command signal generator	See catalog 2470
EHA-RMP-201-A-2* Ramp generator	See catalog 2410B
EHA-PID-201-A-2* PID controller	See catalog 2427
EHA-PSU-201-A-10 Power supply	See catalog 2410B
Installation and start-up:	
Back pressure at port T	Port T should be piped directly to reservoir with minimum restriction. Any back pressure at this port is additive to the controlled pressure at port P. The recommended max. pressure at port T when the valve is controlling pressure is 2 bar (29 psi); the max. pressure at T under static conditions is 210 bar (3000 psi)

Performance Data

Pressure Gain, Typical

Typical pressure v. command signal response of KBCG-3-250 models

Test conditions:
Fluid = Antiwear hydraulic oil at 36 cSt (168 SUS)

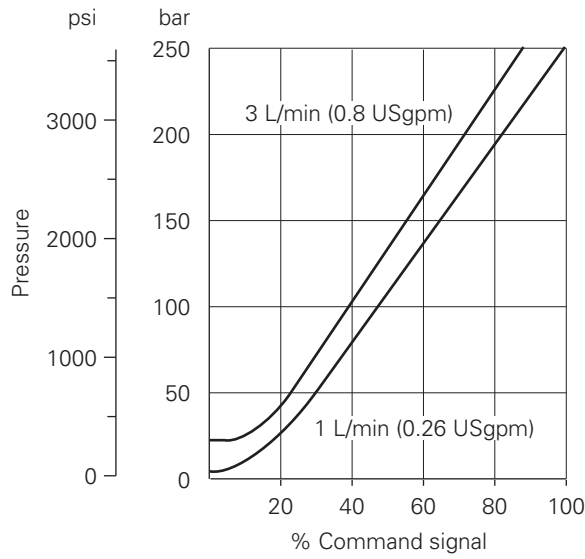

Pressure Override, Typical

Test conditions:
Fluid = Antiwear hydraulic oil at 36 cSt (168 SUS)

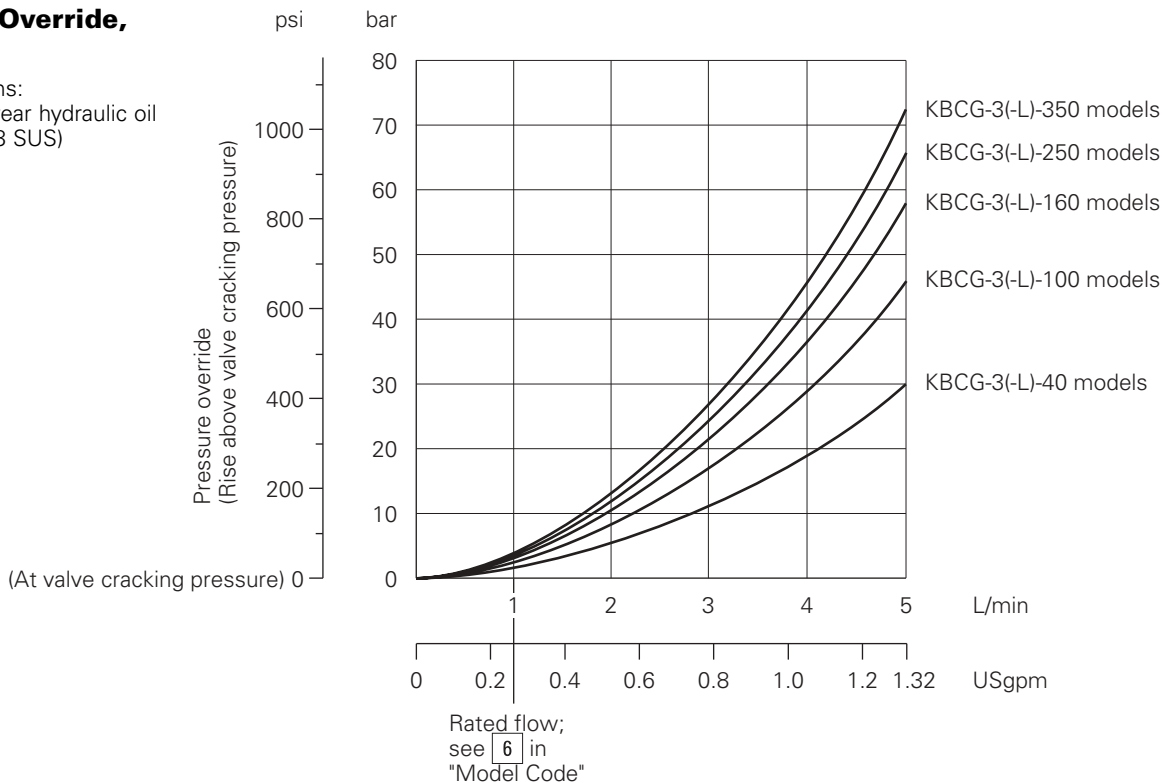

Installation Dimensions

3rd angle
projection

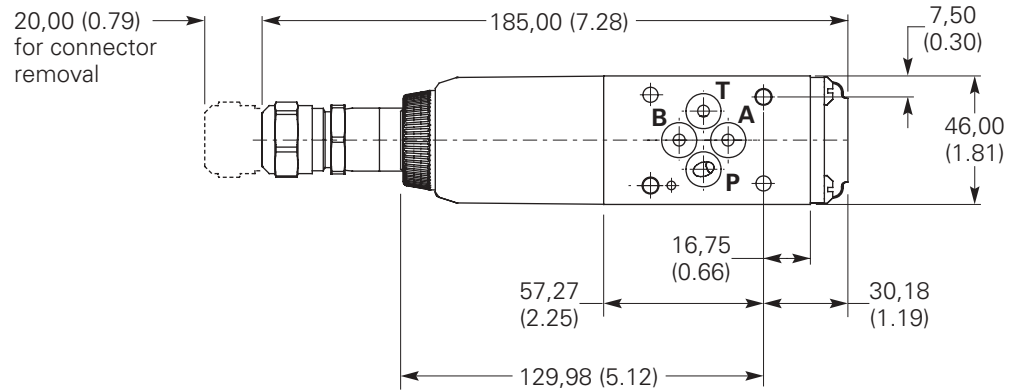
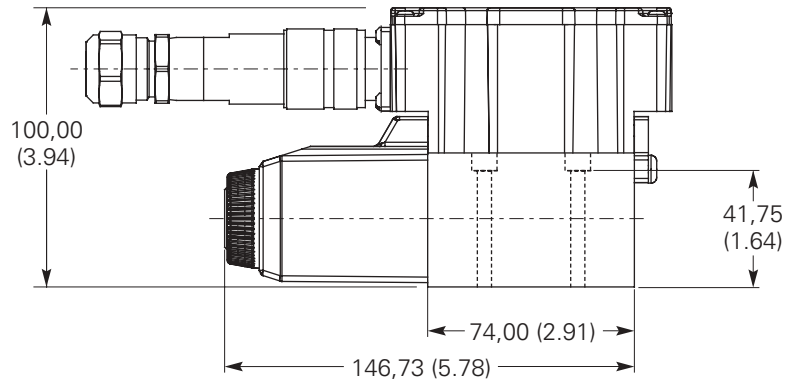
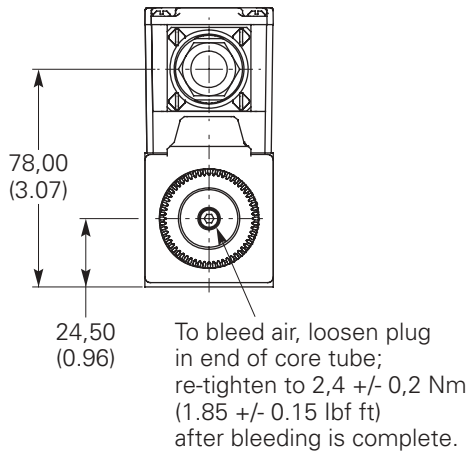
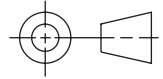

Block Diagram

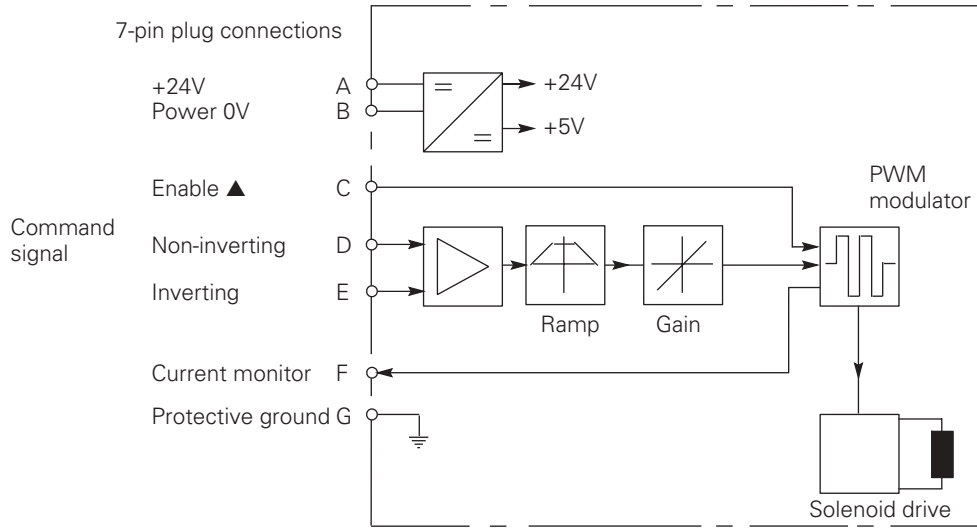

▲ In valves with PH7 or PR7 type electrical connection.

Wiring

Connections must be made via the 7-pin plug mounted on the amplifier. See this leaflet and Installation Wiring Practices for Vickers™ Electronic Products leaflet 2468. Recommended cable sizes are:

Power Cables

For 24V supply:
 0,75 mm² (18 AWG) up to 20m (65 ft)
 1,00 mm² (16 AWG) up to 40m (130 ft)

Signal Cables

0,50 mm² (20 AWG)

Screen (Shield)

A suitable cable should have at least 6 cores with pairs of conductors individually screened and an overall screen. Cable outside diameter 8,0-10,5 mm (0.31- 0.41 inches). See connection diagrams on next page.



Warning

All power must be switched off before connecting or disconnecting any plugs.

Typical Connection Arrangements

Wiring Connections

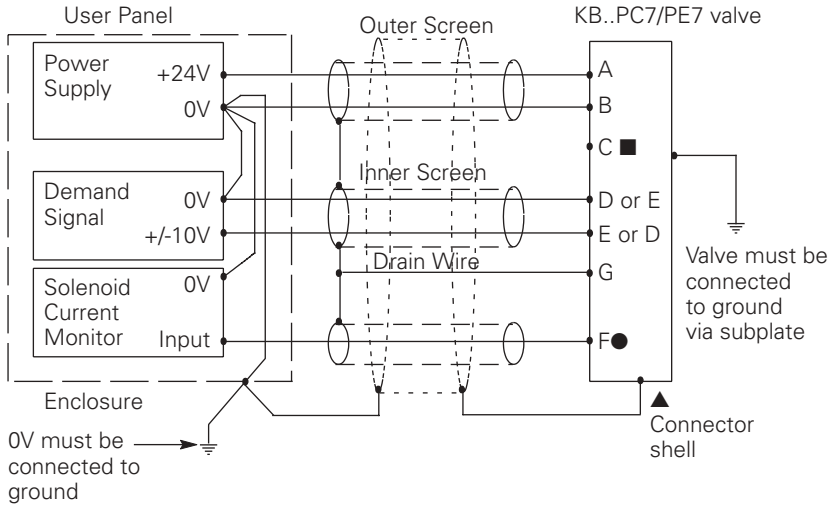

■ Pin C may be connected to ground or left unconnected.

● Output monitor voltage (pin F) will be referenced to the power 0 volts (pin B).

Wiring Connections for Valves with "Enable" Feature

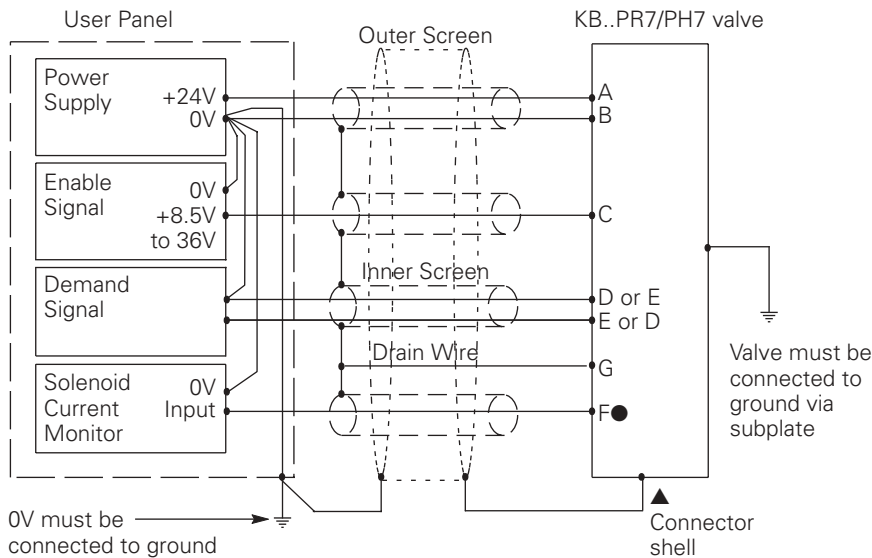

▲ Note:

In applications where the valve must conform to European RFI/EMC regulations, the outer screen (shield) must be connected to the outer shell of the 7-pin connector, and the valve body must be fastened to the earth ground. Proper earth grounding practices must be observed in this case, as any differences in command source and valve ground potentials will result in a screen (shield) ground loop.



Warning

Electromagnetic Compatibility (EMC)

It is necessary to ensure that the valve is wired up as above. For effective protection the user electrical cabinet, the valve subplate or manifold and

the cable screens should be connected to efficient ground points. The metal 7-pin connector part no. 934939 should be used for the integral amplifier.

In all cases both valve and cable should be kept as far away as possible from any

sources of electromagnetic radiation such as cables carrying heavy current, relays and certain kinds of portable radio transmitters, etc. Difficult environments could mean that extra screening may be necessary to avoid the interference.

It is important to connect the 0V lines as shown above. The multi-core cable should have at least two screens to separate the demand signal and monitor output from the power lines.

The enable line to pin C should be outside the screen which contains the demand signal cables.

Further Information

Hydraulic Fluids

Materials and seals used in these valves are compatible with:

Anti-wear petroleum oils...LHM
Non-alkyl based
phosphate esters.....LHFD

The extreme operating range is 500 to 13 cSt (270 to 70 SUS) but the recommended running range is 54 to 13 cSt (245 to 70 SUS). For further technical information about fluids see 694.

Contamination Control Requirements

Recommendations on contamination control methods and the selection of products to control fluid condition are included in publication 9132 or 561, "Guide to Systemic Contamination Control". The book also includes information on the concept of "ProActive Maintenance". The following recommendations are based on ISO cleanliness levels at 2 µm, 5 µm and 15 µm.

For products in this catalog the recommended levels are:

Up to 210 bar
(3000 psi).....18/16/13
Above 210 bar
(3000 psi).....17/15/12

Installation and Start-up Guidelines

The proportional valves in this catalog can be mounted in any attitude but it may be necessary, in certain demanding applications, to ensure that the solenoids are kept full of hydraulic fluid.

If this proves to be the case any accumulated air can be bled from the solenoid bleed screw. This task is easier if the valve has been mounted base downwards. Good installation practice dictates that the tank port, and any drain port, are piped so as to keep the valve full of fluid once the system start-up has been completed.

Temperatures

For petroleum oil:
Min.....-20°C (-45°F)
Max.....+70°C (158°F)

For fluids where limits are outside those of petroleum oil, consult fluid manufacturer or Eaton representative. Whatever the actual temperature range, ensure that viscosities stay within those specified under "Hydraulic Fluids".

Ambient for:

Valves at full performance specification: -20 to +70°C (-4 to +158°F).

Valves, as above, will operate at temperatures of 0 to -20°C (32 to -4°F) but with a reduced dynamic response.

Storage:

-25 to +85°C (-13 to +185°F)

Seal Kit

02-352521

Eaton
14615 Lone Oak Road
Eden Prairie, MN 55344-2287
USA
Tel: (+1) 952 937-9800
Fax: (+1) 952 974-7722
www.hydraulics.eaton.com

Eaton
20 Rosamond Road
Footscray
Victoria 3011
Australia
Tel: (+61) 3 9319 8222
Fax: (+61) 3 9318 5714

Eaton
Dr.-Reckeweg-Str. 1
D-76532 Baden-Baden
Germany
Tel: +49 (0) 7221 682-0
Fax: +49 (0) 7221 682-788

EAT•N

Vickers

© 2003 Eaton Corporation
All Rights Reserved
Printed in USA
Document No. V-VLPO-MC002-E
May 2003