

Vickers®

Control Valve

11-07-702
EN-0400
Old No. 689

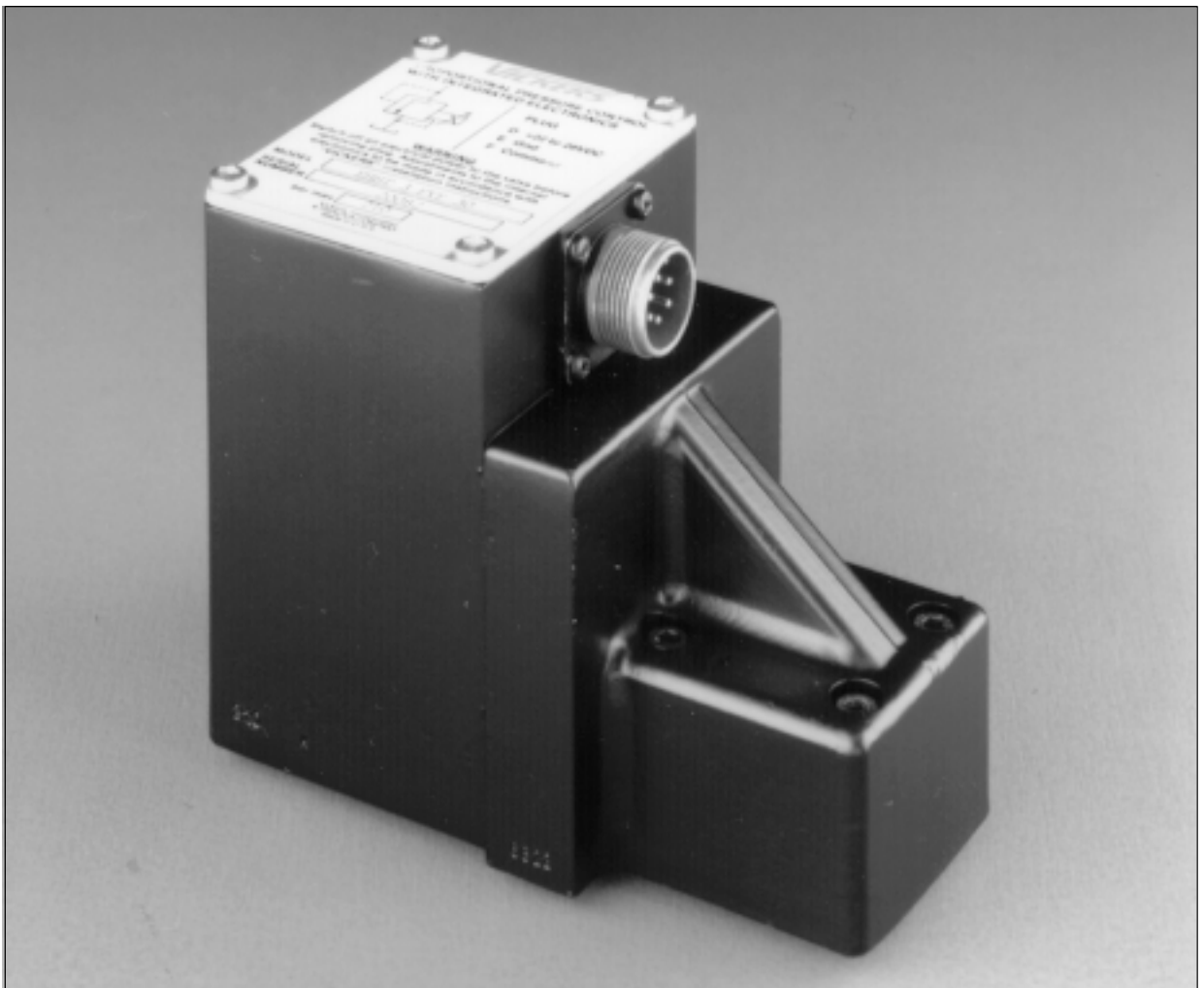

Proportional Pressure Control Valve with Integrated Electronics

EHST-3-30 Series & EHST-3-40 Series (CE Compliant)

General Information

Description

The EHST-3 is a high performance electro-hydraulic proportional relief valve with integral electronics. The valves' extremely linear performance is attributed to a unique innovative design which includes "frictionless" mechanical design, and the use of electronic linearization circuitry.

The -40 design option is the latest addition to the product family which features European CE approval for electromagnetic compatibility.

Application

The EHST-3 valve is ideal for use as a pilot valve for larger pressure control valves, or for control of variable displacement piston pumps. It is particularly suited in applications requiring remote control where an electrical signal can be used to remotely control pressure of a hydraulic system function. Any electronic control system or programmable logic controller which can produce a 0 to 10 volt or a 4-20 mA current command, can be interfaced to the EHST valve.

Operation

The EHST-3 design implements a floating disk armature with a frictionless self-centering ball and seat metering arrangement. A proportional solenoid/disk armature forces the ball into a metering seat area, thus controlling the "P" port pressure proportional to command signal.

The total lack of springs, bearings, or sliding components provides a design which is essentially free of mechanical friction.

The very repeatable transfer function of the basic solenoid / valve arrangement is linearized by an onboard electronic compensation network. The combination of a very repeatable inherent valve transfer function and onboard compensation electronics results in a valve linearity which is within 1% of full scale.

Model Code

EHST-3- * * * -40

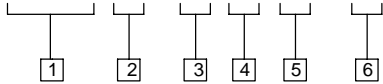

1 Proportional Pressure Control with Integrated Electronics

2 Mounting interface

3 – ISO 4401 Size 3, ANSI/B93.7M size D03

3 Pressure range

(At nominal flow rating; 1 l/min [0.26 US gpm])
B – 4-90 bar (58-1305 psi)
F – 5,5-210 bar (78-3045 psi)

4 Command (input) signal

I – 4 to 20 mA, DC
V – 0 to +10V, DC

5 Output bias

E – Pressure bias
F – Signal bias

6 Design number, 30 series

-30 Standard unit
-40 CE compliant unit

Subject to change; installation dimensions unaltered for design numbers 40 to 49 inclusive.▲

▲Note:
The -40 design series product has been designed and tested to meet specific standards outlined in the European Electromagnetic Compatibility Directive as specified by EN 50 082-2; emission, and EN 50 082-2; susceptibility. For installation requirements, refer to Installation Wiring Practices for Vickers Electronic Products leaflet 2468.

Construction of EHST-3 valve

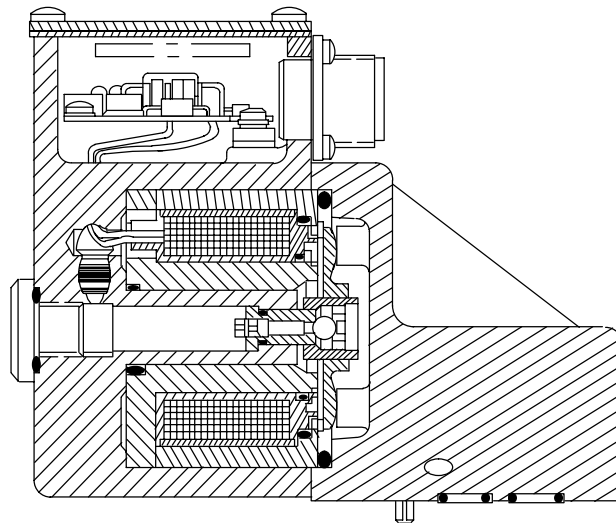

Operating Data

EHST-3-30 & EHST-3-40 Proportional Pressure Control Valves

Valve control function	Proportional relief						
Valve hydraulic interface	ISO 4401, size 3 ANSI/B93.7M size D03						
Command signal voltage CMD option: current CMD option:	0-10V DC (nominal impedance 32 k Ω) 4-20 mA (nominal impedance 200 Ω)						
Linearity	$\leq 1.0\%$						
Hysteresis (between 5 and 100% of rated output)	$\leq 2.4\%$						
Maximum pressures: Port P Port T Minimum controllable pressure @ 1 l/min. 210 bar (3045 psi) F model 90 bar (1300 psi) B models	90 bar (1305 psi) or 210 bar (3045 psi) depending on model 20 bar (290 psi) NOTE: Pressure in port T is <i>additive</i> to the controlled pressure and significantly affects minimum pressure capability of the valve. For optimum performance and to avoid high cyclic system pressure peaks, connect port T directly to tank. 5.5 bar (80psi) 4.0 bar (60 bar)						
Flow rates: Rated flow (Optimum valve performance) Maximum flow	1 l/min (0.26 US gpm) 2,5 l/min (0.65 US gpm)						
Power supply	24V (22 to 28V) DC at 1,2A Max. ripple 10% peak to peak						
Protection classifications: Coil winding Valve fitted with MS3102E-14S-6P receptacle Mating 3 plug	Class F insulation IEC 144 Class IP65 MS3106A-14S-6P						
Relative duty factor	100% (continuously rated)						
Operating temperatures: Ambient Fluid	-20°C to 50°C (-4°F to 122°F) 80°C (176°F) maximum						
Hydraulic fluids	These valves are fitted with standard (nitrile rubber) seals are suitable for use with anti-wear hydraulic oils. Optimum valve performance is obtained using fluids in the viscosity range 54 to 13 cSt (245 to 70 SUS). The extreme operating viscosity range is 500 to 13 cSt (2200 to 70 SUS).						
Filtration	<i>System Pressure psi (bar)</i> <table border="0"> <tr> <td><70 (<2000)</td> <td>70–210 (2000–3045)</td> <td>210+ (3045+)</td> </tr> <tr> <td>17/15/12</td> <td>17/15/12</td> <td>15/13/11</td> </tr> </table>	<70 (<2000)	70–210 (2000–3045)	210+ (3045+)	17/15/12	17/15/12	15/13/11
<70 (<2000)	70–210 (2000–3045)	210+ (3045+)					
17/15/12	17/15/12	15/13/11					
Installation data: Mounting attitude	No restrictions.						
Weight	2,6 kg (4.8 lbs.)						

Valve Performance

Maximum pressure envelope

Set by on-board potentiometer "P_{max}"

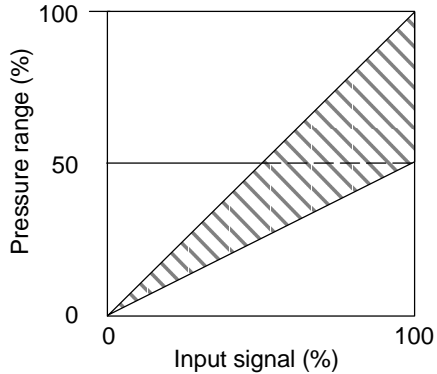

Pressure override: bar (psi)

Valve type	Set pressure	Pressure over-ride	
		at 1 l/min (0.26 US gpm)	at 2 l/min (0.52 US gpm)
-E**-	90 (1305)	1 (14.5)	2,7 (39)
	60 (870)	0,7 (10)	2 (29)
	30 (435)	0	0,2 (2.9)
-F**-	210 (3045)	10 (145)	20 (290)
	180 (2610)	9 (130)	19 (275)
	120 (1740)	8 (116)	18 (261)
	60 (870)	6 (87)	18 (261)

Bias setting

Relative to max. pressure, and set by on-board potentiometer "P_{corr}"

Pressure bias, EHST-3-**E

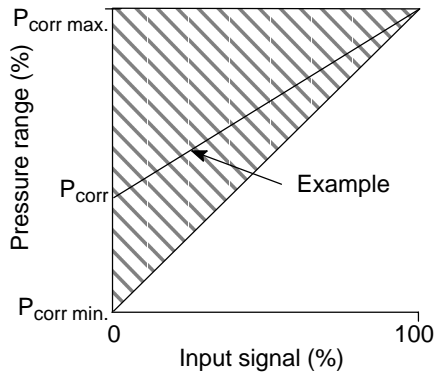

Temperature drift: bar (psi)

Valve type	Set pressure @ 30°C (86°F)	Drift coefficient ▲		Reduction from set pressure @ 70°C (158°F)
		bar/°C	psi/°F	
-E**-	90 (1305)	0,066	(0.53)	2,64 (38)
	60 (870)	0,046	(0.37)	1,86 (27)
	30 (435)	0,016	(0.13)	0,66 (10)
-F**-	210 (3045)	0,131	(1.1)	5,24 (76)
	120 (174)	0,075	(0.6)	3 (44)
	60 (870)	0,037	(0.23)	1,48 (22)

▲ Pressure reduces as temperature increases;
pressure increases as temperature reduces.

Signal bias, EHST-3-**E

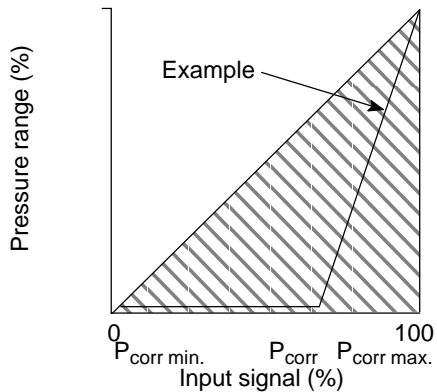

Dynamic performance

Frequency response at conditions of:
 Trapped volume 10 ml (0.6 in³)
 Operating point 50% max. signal
 Amplitude ± 10% max. signal
 Input signal form sinusoidal
 Flow rate 1 l/min (0.26 US gpm)

Valve type	Frequency at -3 dB	Frequency at 90° phase lag
-E**-	190 Hz	120 Hz
-F**-	120 Hz	70 Hz

Configuration & Adjustments

Configuration

EHST valves are pre-configured by model code when ordered from the factory. Configuration options include selection of command input type (voltage or current), and output bias (command or pressure). These configurations can be field selected by setting the configuration jumpers on the internal circuit board. Refer to the chart on this page for the required jumper positions, and the circuit board illustrations for placement.

Configuration Jumper Settings

Command Signal	Jumper Position					
	A	B	C	D	E	F
Voltage option		X		X		
Current option	X		X			
Output Bias						
Pressure option					X	
Signal option						X

X=Jumper installed

Warning: Disconnect the valve electrical connector before making any jumper changes.

Potentiometer Adjustments

Two adjustments are provided on the internal circuit board; maximum pressure, and the pressure bias. The locations on the circuit board is dependent on the model series number as shown below.

Refer to Vickers Installation and Commissioning guidelines; leaflet #B9055 (P/N 866371) for start-up assistance.

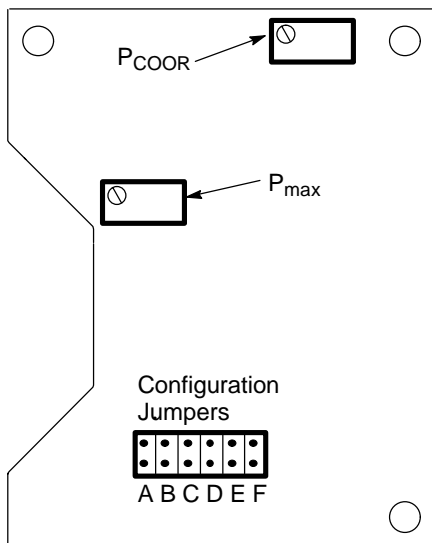

EHST-3-30 Series

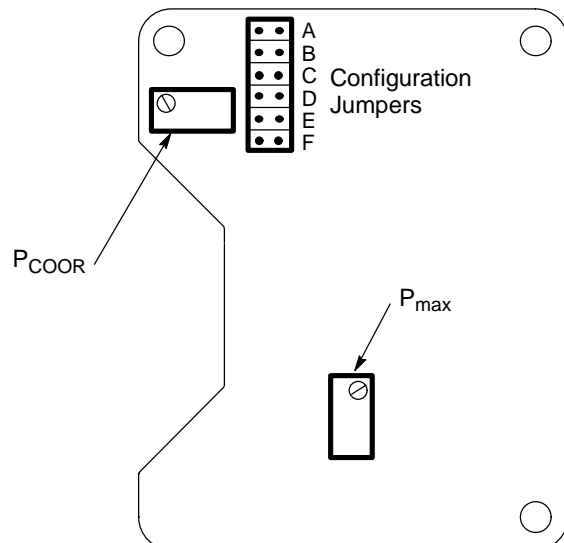

EHST-3-40 Series (CE compliant)

Installation – Electrical

Wiring

Wiring connections are made to the EHST via a 6-pin plug connector. Note that the minimum wire gage specified is for applications less than 30 meters (100 feet). Consideration should be given for additional installed length, and mechanical robustness.

Mating Connector

Type: MS3106A-14S Plug (connections shown are solder side)

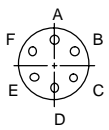

Plug (solder side)

Electrical plug pins

- A – not used
 - B – not used
 - C – chassis gnd (-40 design only)
 - D – +24 VDC power supply
 - E – 0V (Ground)
 - F – Command (input)
- 0 to +10 VDC (EHST-3-*V* models)
4 to 20 mA (EHST-3-*I* models)

Electrical Block Diagram - Internal

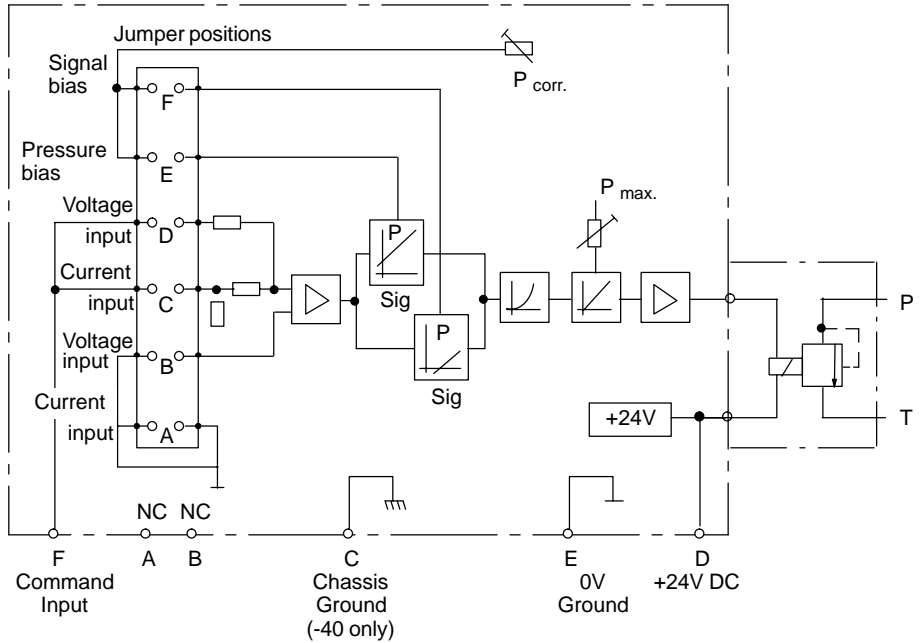

Wire

0,5/1,5 mm² section (20 gage) minimum. Shielded, 3 insulated conductors, with 1 bare in contact with shield braid.

Cable outside diameter: 8/12 mm (0.31/0.47") to fit plug strain relief.

Application Wiring Diagram - External

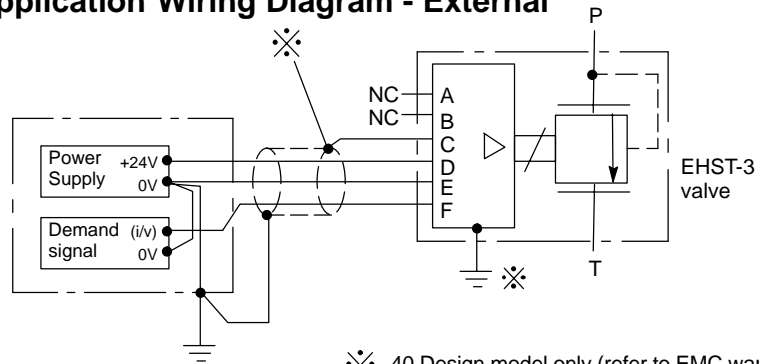

⊗ -40 Design model only (refer to EMC warning)



Warning

Electromagnetic Compatibility (EMC)

The -40 design series product has been designed and tested to meet specific standards outlined in the European Electromagnetic Compatibility Directive. It is necessary to ensure that the valve is wired as shown. In all cases both valve and interconnecting cabling should be kept as far as possible from any sources of electromagnetic radiation such as cables carrying large currents, relays and radio transmitters, etc. Difficult environments could mean that extra screening may be necessary to avoid interference.

In applications where the valve must conform to European RFI/EMC regulations, the chassis ground (pin C) must be connected to the cable screen (shield), and the valve body must be fastened to earth ground. Proper grounding practices must be observed in this case, as any differences in command source and valve ground potentials may result in a screen (shield) ground loop.

Installation Dimensions

mm (inches)

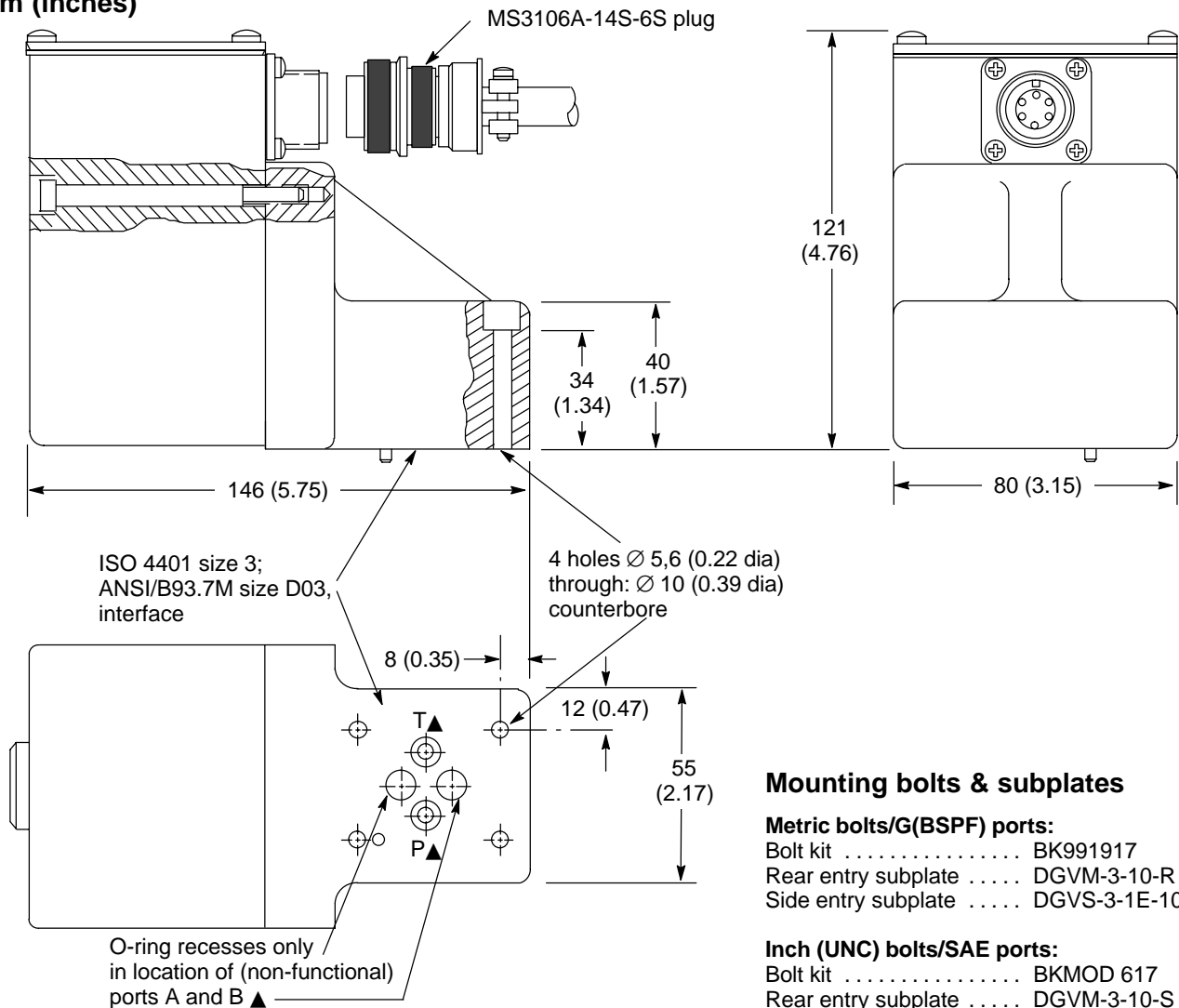

▲ O-rings (4 req'd) supplied with valve

Mounting bolts & subplates

Metric bolts/G(BSPF) ports:

Bolt kit BK991917
Rear entry subplate DGVM-3-10-R
Side entry subplate DGVS-3-1E-10-R

Inch (UNC) bolts/SAE ports:

Bolt kit BKMOD 617
Rear entry subplate DGVM-3-10-S
Side entry subplate DGMS-3-1E-10-S

Fluid Cleanliness

Proper fluid condition is essential for long and satisfactory life of hydraulic components and systems. Hydraulic fluid must have the correct balance of cleanliness, materials and additives for protection against wear of components, elevated viscosity and inclusion of air.

Essential information on the correct methods for treating hydraulic fluid is included in Vickers publication 561; "Vickers Guide to Systemic Contamination Control," available from your local Vickers distributor or by contacting Vickers, Incorporated. Recommendations on filtration and the selection of products to control fluid condition are included in 561.

Vickers products, as any components, will operate with apparent satisfaction

in fluids with higher cleanliness codes than those described. Other manufacturers will often recommend levels above those specified.

Experience has shown, however, that life of any hydraulic components is shortened in fluids with higher cleanliness codes than those listed below. These codes have been proven to provide a long trouble-free service life for the products shown, regardless of the manufacturer.

Fire resistant fluids usually have higher specific gravities than oil. The specific gravity of a fluid may be obtained from its producer.

Recommended cleanliness levels, using petroleum oil under common conditions, are based on the highest

fluid pressure levels in the system and are coded in the chart below. Fluids other than petroleum, severe service cycles or temperature extremes are cause for adjustment of these cleanliness codes.

Troubleshooting

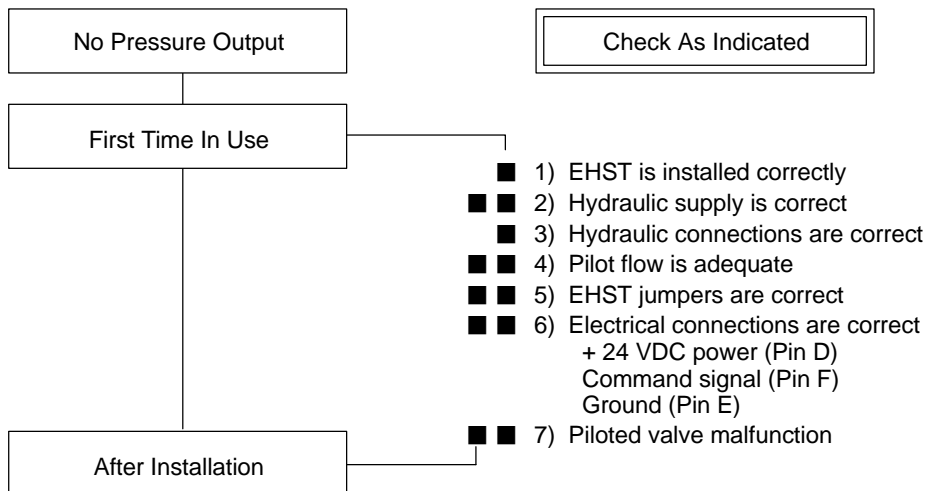
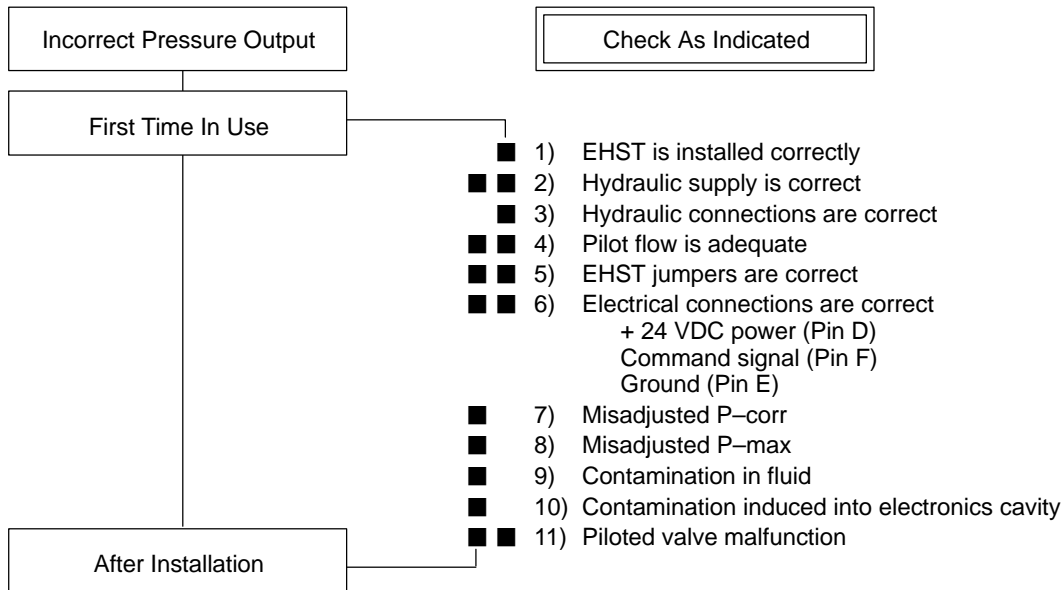

Eaton Hydraulics
14615 Lone Oak Road
Eden Prairie, MN 55344
Telephone: 952 937-7254
Fax: 952 937-7130
www.eatonhydraulics.com

46 New Lane, Havant
Hampshire PO9 2NB
England
Telephone: (44) 170-548-6451
Fax: (44) 170-548-7110