

# Unloading Relief Valves

EURG1/2-06/10, 13 Design and EURT1/2-06/10, 12 Design

## Sectional Illustrations

EURG\*

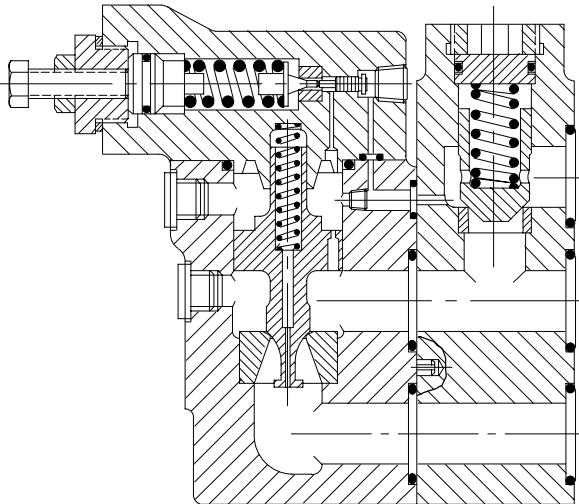

EURT\*

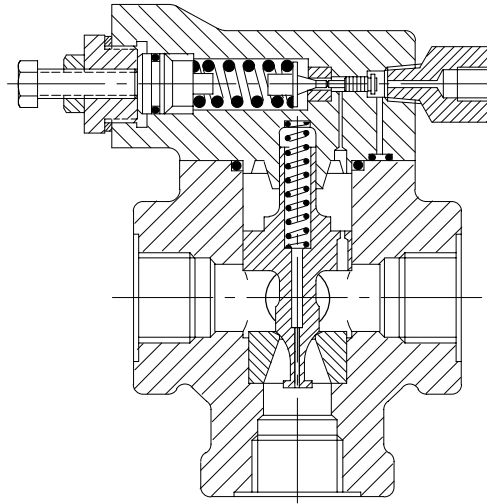

### Basic Characteristics

Mounting . . . Pipe or subplate mounting  
 Unloading pressure . . . . . Up to 210 bar  
 (3000 psi)  
 Rated flow . . . . . Up to 246 L/min  
 (65 USgpm)  
 Method of actuation . . . Internally piloted

### General Description

Unloading relief valves are primarily used in hydraulic circuits incorporating accumulators where a pressure regulator is required to automatically unload the pump when the pressure reaches the pre-adjusted pressure setting of the valve.

When the pressure has dropped to approximately 85% of the valve setting the valve spool closes, thus diverting the pump delivery to the accumulator.

On the EURG models an integral check valve prevents return flow from the accumulator through the unloading valve; for the EURT model to provide this function a separate right angle check valve, model C2-815 (3/4") or C2-825 (1 1/4") must be provided.

These valves may also be used with a double pump to deliver a large volume of oil to the system at low pressure and a small volume at high pressure, serving the same function as a separate unloading valve and check valve.

## Functional Symbols

EURG1

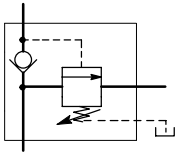

EURG2

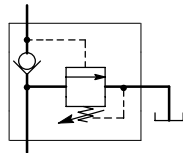

EURT1

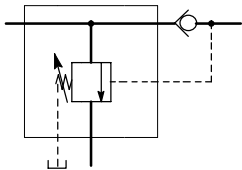

EURT2

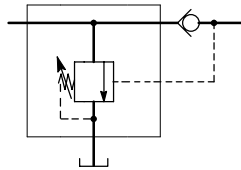

## Applications

### 1. Single pump/accumulator system

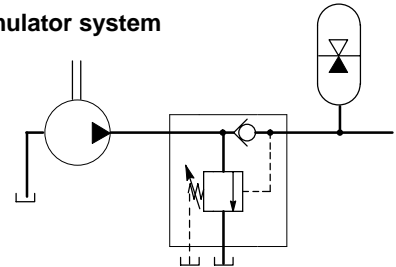

### 2. Double pump system

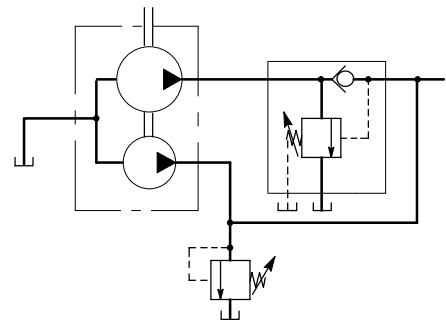

Note that the EURG1 model shown in both systems can be replaced by the EURG2 or an EURT\* plus the external check valve

## Model Codes

### Valves

**(F3) - EUR \* \* - \*\* - \* (V) - \*\* \*\***

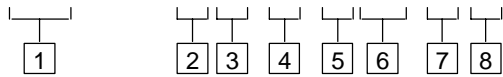

**1 Seals for phosphate ester fluids**  
(See also the "Hydraulic Fluids" section)  
Omit if not required

**2 Mounting method**  
G = Subplate mounted  
T = Pipeline mounted

**3 Drain**  
1 = External drain  
2 = Internal drain

**4 Nominal port size**  
06 = 3/4"  
10 = 1 1/4"

**5 Pressure adjustment range**  
B = 25 - 69 bar (350 - 1000 psi)  
C = 35 - 138 bar (500 - 2000 psi)  
F = 104 - 210 bar (1500 - 3000 psi)

**6 High venting spring**  
EURG models only  
Omit if not required

**7 Design number**  
12 = EURT model  
13 = EURG model  
Design numbers are subject to change.  
Installation dimensions remain the same for design numbers 10 to 19 inclusive.

**8 Port tappings/fixing bolts**  
UB = G (BSPF) port tappings (EURT models)  
UG = Accept metric or inch fixing bolts (EURG models)

### Subplate

**EURG1M - \*\* - 20 - R**

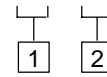

**1 Nominal port size**  
06 = 3/4"  
10 = 1 1/4"

**2 Design number, 20 series**  
Subject to change. Installation dimensions remain the same for design numbers 20 to 29 inclusive.

**Metric Fixing Bolt Kits**  
(EURG valves)  
BKUR-06-682M for EURG-06 valves  
E-BKUR-10-683M (Assy. no. 460852) for EURG-10 valves

## Operating Data

### Max. Pressures

Pressure inlet and system ports . . . Up to 210 bar (3000 psi) dependent on model

Tank ports

EUR\*1 models . . . . . Up to 85% of inlet pressure

EUR\*2 models . . . . . Up to 5% of inlet pressure

Pilot pressure port

EURT\* models . . . . . Up to 210 bar (3000 psi) dependent on model

Drain port

EUR\*1 models . . . . . Drain must be connected to tank through a surge free line so there will be no back pressure at this port.

Failure to connect the drain can result in infinite system pressures and machine damage.

EURT2 models are internally drained and this port is not used.

### Pressure Adjustment Range

See "Model Code".

### Flow Data

Rated flow, L/min (USgpm)

EURT\*-06 . . . . . 75 (284)

EURG\*-06 . . . . . 95 (360)

EURT\*-10 . . . . . 190 (720)

EURG\*-10 . . . . . 246 (930)

## Hydraulic Fluids

All valves can be used with antiwear hydraulic oils, water-in-oil emulsions and water-glycols. Add prefix "F3" to model designation when phosphate ester (not alkyl-based) or chlorinated hydrocarbons are to be used.

The extreme operating viscosity range is from 860 to 13 cSt (4000 to 70 SUS), but the recommended running range is 54 to 13 cSt (245 to 70 SUS).

For further information about fluids see leaflet 694.

## Temperature Limits

### Ambient

Min. . . . . -20°C (-4°F)

Max. . . . . +70°C (+158°F)

### Fluid Temperature

	Petroleum oil	Water-containing
Min.	-20°C (-4°F)	+10°C (50°F)
Max.*	+80°C (176°F)	+54°C (130°F)

\* To obtain optimum service life from both fluid and hydraulic system 65°C (150°F) normally is the maximum temperature except for water-containing fluids.

For synthetic fluids consult manufacturer or Vickers representative where limits are outside those for petroleum use.

Whatever the actual temperature range, ensure that viscosities stay within the limits specified in the "Hydraulic Fluids" section.

## Contamination Control Requirements

Recommendations on contamination control methods and the selection of products to control fluid condition are included in Vickers publication 9132 or 561, "Vickers Guide to Systemic Contamination Control". The book also includes information on the Vickers concept of "ProActive Maintenance". The following recommendations are based on ISO cleanliness levels at 2 µm, 5 µm and 15 µm. For products in this catalog the recommended levels are:  
Up to 210 bar (3000 psi) . . . . . 19/17/14

# Installation Dimensions in mm (inches)

## EURG\*-06/10

Cover fixing screws, 4 off:

**EURG\*-06:** M8 socket head cap screw  
Torque to 32-36 Nm (24-26 lbf ft)

**EURG\*-10:** M10 socket head cap screw  
Torque to 62-70 Nm (46-51 lbf ft)

3rd angle projection

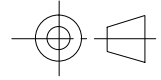

Vent port:

**EURG\*-06:** G<sup>1</sup>/<sub>8</sub> (1/8" BSPF)  
Torque to 6,8-7,5 Nm (60-66 lbf in)

**EURG\*-10:** G<sup>1</sup>/<sub>4</sub> (1/4" BSPF)  
Torque to 15,3-16,4 Nm (11.3-12 lbf ft)  
(If not used port must remain plugged)

Pressure gage port:

**EURG\*-06:** G<sup>1</sup>/<sub>8</sub> (1/8" BSPF)  
Torque to 8,4-9,6 Nm (74-85 lbf in)

**EURG\*-10:** G<sup>1</sup>/<sub>4</sub> (1/4" BSPF)  
Torque to 15,3-16,4 Nm (11.3-12 lbf ft)

Drain connection **EURG1** only:  
G<sup>1</sup>/<sub>4</sub> (1/4" BSPF). Torque to  
15,3-16,4 Nm (11.3-12 lbf ft)

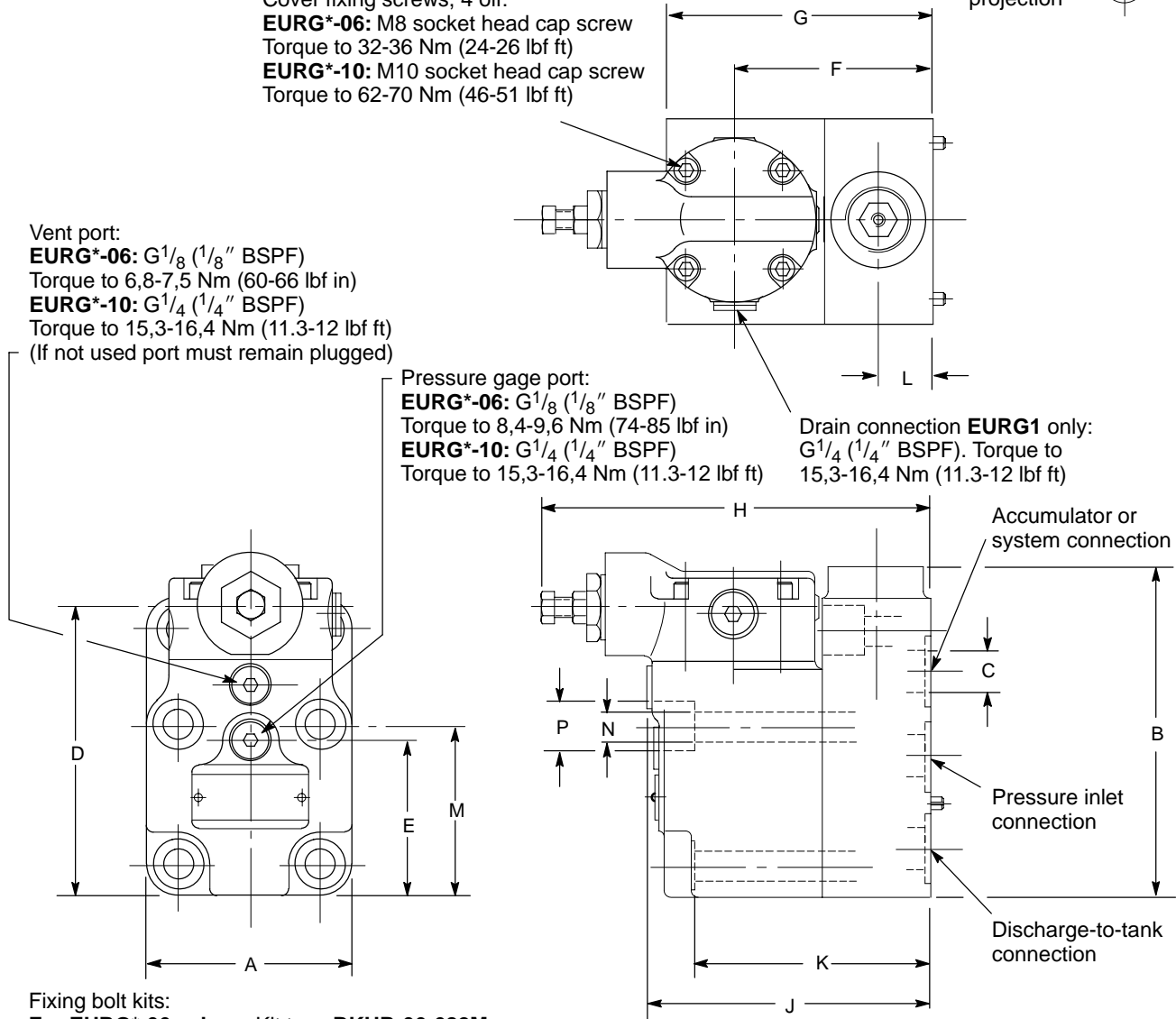

Fixing bolt kits:

**For EURG\*-06 valves:** Kit type **BKUR-06-682M**

Torque to 257-317 Nm (190-233 lbf ft), lubricated

**For EURG\*-10 valves:** Kit type **E-BKUR-10-683M**

Torque to 503-615 Nm (370-453 lbf ft), lubricated

For mounting subplates see next page.

Model	A	B	C	D	E	F	G	H	J	K	L	M	N	P
EURG*-06	101,6 (4.0)	160,3 (6.31)	23 (0.91)	139,7 (5.5)	76,2 (3.0)	92,2 (3.63)	124,0 (4.88)	181,0 (7.13)	134,1 (5.28)	108,0 (4.25)	25,4 (1.0)	82,8 (3.26)	17 (0.67)	26 (1.02)
EURG*-10	120,7 (4.75)	217,5 (8.56)	28,6 (1.13)	179,3 (7.06)	95,3 (3.75)	117,6 (4.63)	157,2 (6.19)	206,3 (8.12)	167,6 (6.6)	138,1 (5.44)	33,3 (1.31)	108 (4.25)	21 (0.83)	32 (1.26)

Subplate for EURG\*-06/10 Valves

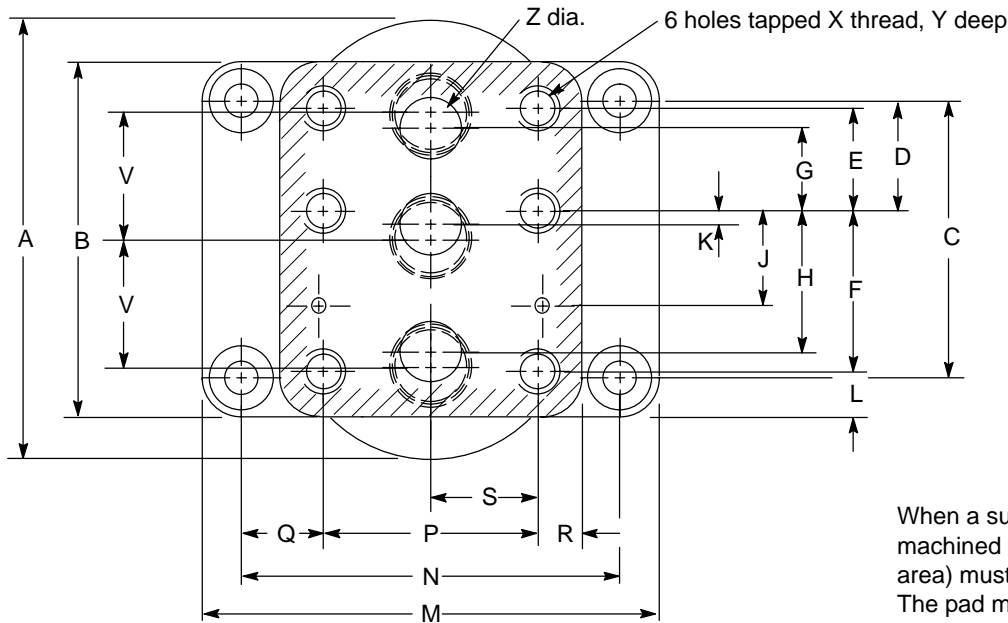
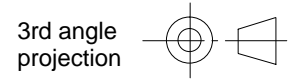

When a subplate is not used, a machined pad (as indicated by shaded area) must be provided for mounting. The pad must be flat within 0,013 mm (0.0005 in) and smooth within 1,6  $\mu\text{m}$  (63 microinch). Mounting bolts provided by the customer should be Class 12,9 (ISO 898) or better.

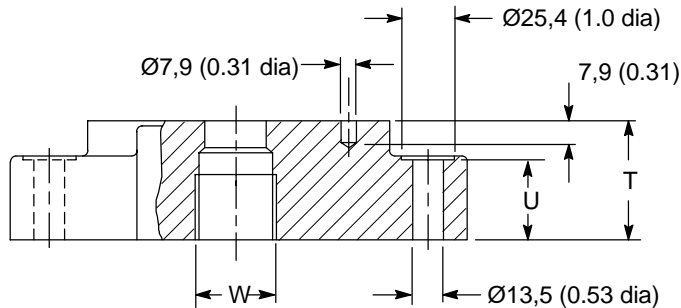

Model	A	B	C	D	E	F	G	H	J	K	L	M
EURG1M-06	–	145 (5.71)	113 (4.38)	46 (1.81)	46 (1.81)	66,7 (2.63)	33,3 (1.31)	55,6 (2.19)	33,3 (1.31)	11,1 (0.44)	15,9 (0.63)	162 (6.34)
EURG1M-10	200 (7.87)	178 (7.0)	146,1 (5.75)	54 (2.13)	50,8 (2.0)	88,9 (3.5)	38,1 (1.5)	76,2 (3.0)	44,5 (1.75)	12,7 (0.5)	19,1 (0.75)	184 (7.24)

Model	N	P	Q	R	S	T	U	V	W	X	Y	Z
EURG1M-06	130,2 (5.13)	69,9 (2.75)	30,2 (1.19)	15,9 (0.63)	34,9 (1.37)	39,9 (1.57)	23,9 (0.94)	48,3 (1.9)	G <sup>3</sup> / <sub>4</sub> "	M16	Thru' 40 (1.57)	23 (0.91)
EURG1M-10	152,4 (6.0)	82,6 (3.25)	34,9 (1.37)	19,1 (0.75)	41,3 (1.63)	50 (1.97)	30,2 (1.19)	64,3 (2.53)	G <sup>1</sup> / <sub>4</sub> "	M20		28,6 (1.13)

**EURT\*-06/10**

3rd angle projection

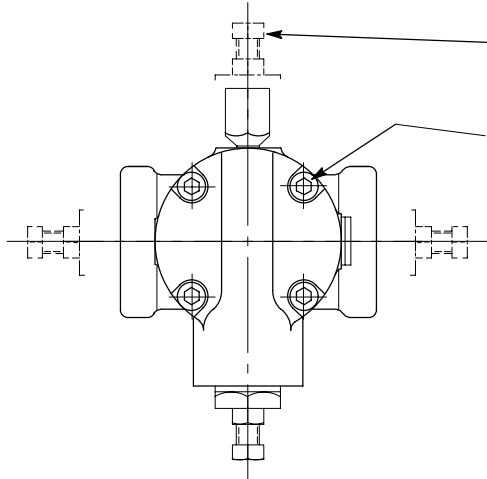
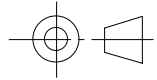

4 optional positions for adjustment control may be obtained by rotating cover to required position

Cover fixing screws, 4 off:

**EURT\*-06:** M8 socket head cap screw  
Torque to 32-36 Nm (24-26 lbf ft)

**EURT\*-10:** M10 socket head cap screw  
Torque to 62-70 Nm (46-51 lbf ft)

Pressure inlet or outlet connection:

**EURT\*-06:** G<sup>3/4</sup> (3/4" BSPF)

**EURT\*-10:** G1<sup>1/4</sup> (1 1/4" BSPF)

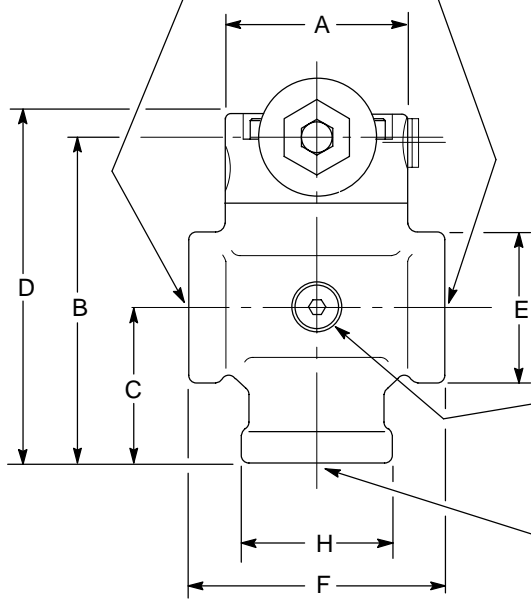

Pilot pressure connection for unloading pump, G<sup>1/4</sup> (1/4" BSPF)

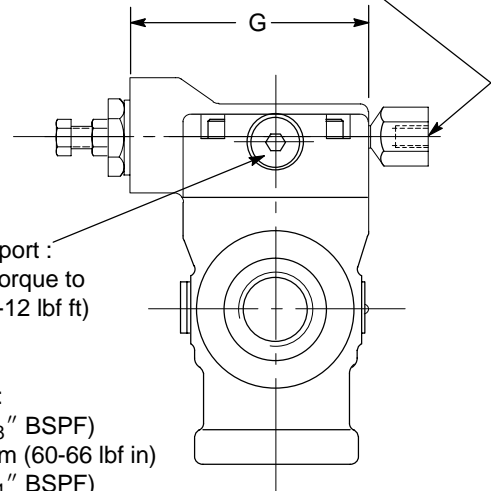

**EURT1 only:** Drain port :  
G<sup>1/4</sup> (1/4" BSPF). Torque to 15,3-16,4 Nm (11.3-12 lbf ft)

Pressure gage port:

**EURT\*-06:** G<sup>1/8</sup> (1/8" BSPF)

Torque to 6,8-7,5 Nm (60-66 lbf in)

**EURT\*-10:** G<sup>1/4</sup> (1/4" BSPF)

Torque to 15,3-16,4 Nm (11.3-12 lbf ft)

Discharge-to-tank connection:

**EURT\*-06:** G<sup>3/4</sup> (3/4" BSPF)

**EURT\*-10:** G1<sup>1/4</sup> (1 1/4" BSPF)

Model	A	B	C	D	E	F	G	H
EURT*-06	77,7 (3.06)	133,4 (5.25)	65 (2.56)	159 (6.26)	57,2 (2.25)	108,0 (4.25)	127,8 (5.03)	63,5 (2.5)
EURT*-10	95,3 (3.76)	165,1 (6.5)	76,2 (3.0)	189 (7.44)	76,2 (3.0)	127,0 (5.0)	137 (5.39)	76, (3.0)

---

## Mass, kg (lb)

EURG*-06 .....	11,4 (25.0)
EURG*-10 .....	22,1 (48.6)
EURT*-06 .....	4,6 (10.1)
EURT*-10 .....	9,1 (20.0)
EURG1M-06 .....	5,7 (12.5)
EURG1M-10 .....	9,3 (20.5)

## Mounting Attitude

Optional.

## Ordering Procedure

Before ordering check availability with the Vickers representative. Valves, subplates and bolt kits are supplied as separate items and must be ordered as such, e.g.

2 off -EURG1-06-B-13-UG valves  
2 off -EURG1M-06-20-R subplates  
2 off -BKUR-682M bolt kits

If a EURT valve is required then a check valve is also needed and must be ordered separately. The check valves recommended are C2-815 ( $3/4''$ ) or C2-825 ( $1\frac{1}{4}''$ ). For further details of these valves refer to leaflet 2334.