

Service Data

Vickers®

Directional Valves



Manual Four-Way Directional Valves

C-430/32/34/76/78-(*)-(*)-(S*)

C-1410/12/30/32/34/50/52/54-(*)-(*)-(S*)

C2-1434-1454-(*)-(*)

**C-430, C-432, C-476, C-478,
C-1410, C-1412**

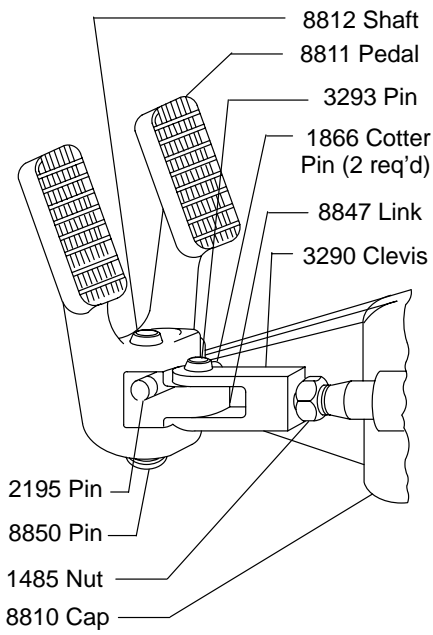

SUFFIX "F" MODELS

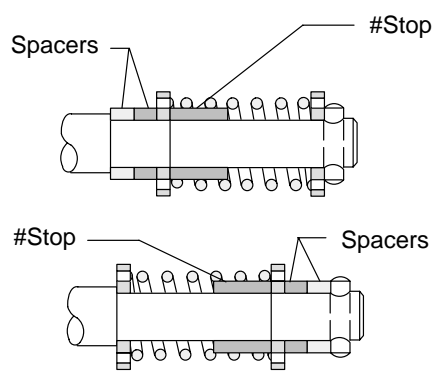

SUFFIX "B" MODELS

Model	Sleeve	Spring
C-430/32-(*)-NS	42904	21982
C-476/78-(*)-NS	20079	
C-1410/12-(*)-NS	21567	2954

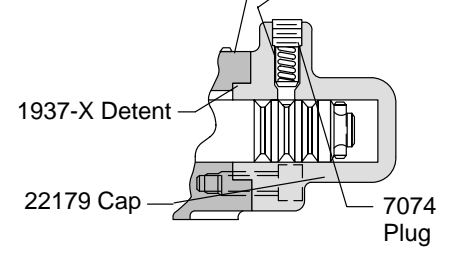

SUFFIX "NS" MODELS

Models	Spacer	Qty.
C-476/78-(*)-NS	2402	1
C-430/32/76/78 Basic, Suffix A or B		2
C-1410, C-1412 Suffix A or B	8947	2
C-1410/12 Basic		3

**BASIC MODEL-STEM CONTROL
SPRING CENTERED SPOOL ASSY. SHOWN**

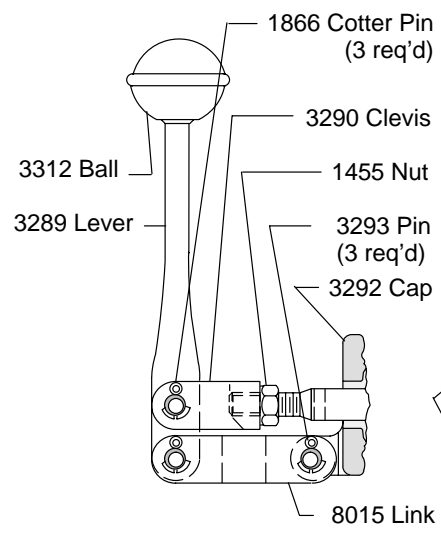

SUFFIX "C" MODELS

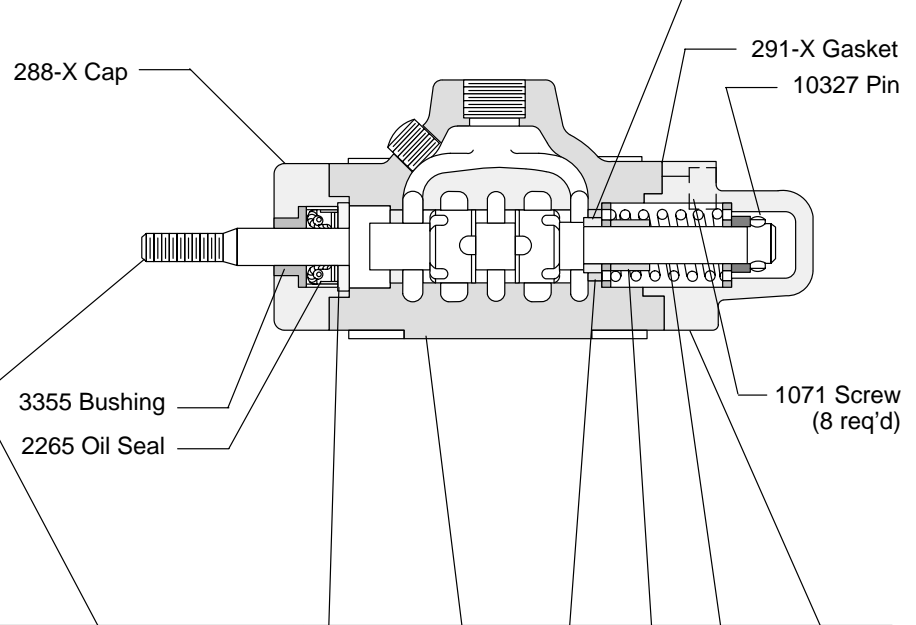

Model	Valve Spool					Washer	Body	Not Used on "NS" Models			
	Basic	S1	S2	S3	S4			Washer	#Stop	Spring	Cap
C-430	11590	10217	27826	—	—	10670	332-X	335-X 2 req'd	2271	333-X	
C-432	929-X	—	—	15250	32031		2155-X		177640		
C-476	1897-X1	—	—	10369	2171-X		—		—		
C-478	737-X	33281	33282	—	—		—		—		
C-1410	10714	30183	31712	—	—	—	8946	8944	27271	8945	
C-1412	8943	—	—	27936	33283	—	—	—	—	—	

**C-430, C-432, C-476, C-478,
C-1410, C-1412**

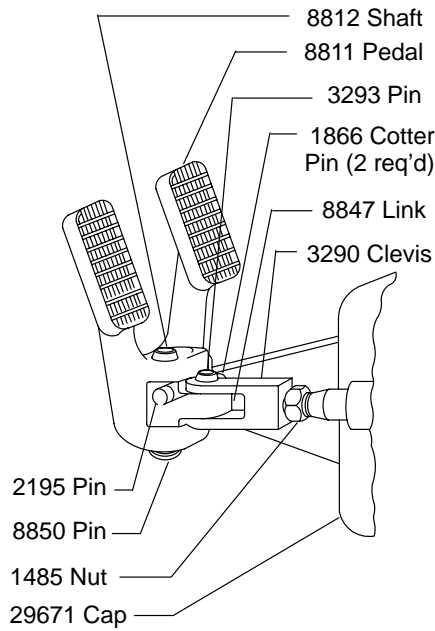

SUFFIX "F" MODELS

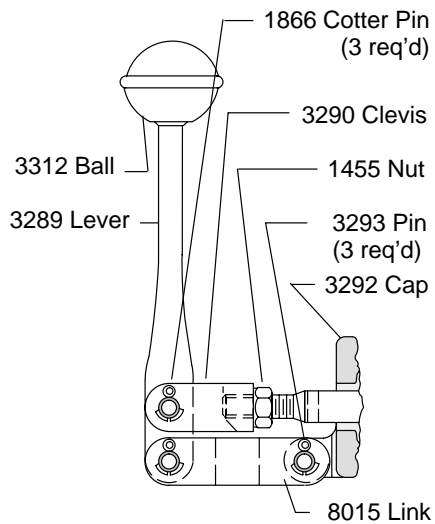

SUFFIX "C" MODELS

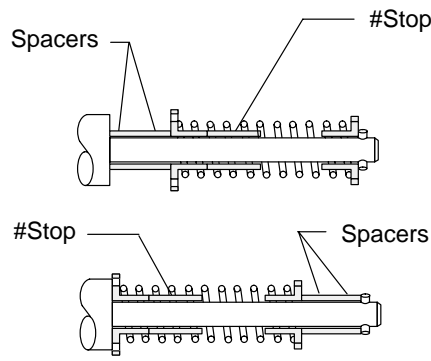

SUFFIX "B" MODELS

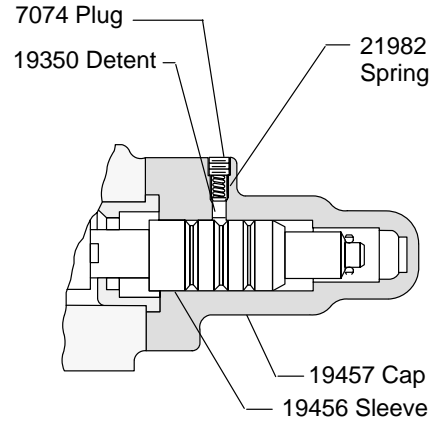

SUFFIX "NS" MODELS

**BASIC MODEL-STEM CONTROL
SPRING CENTERED SPOOL ASSY. SHOWN**

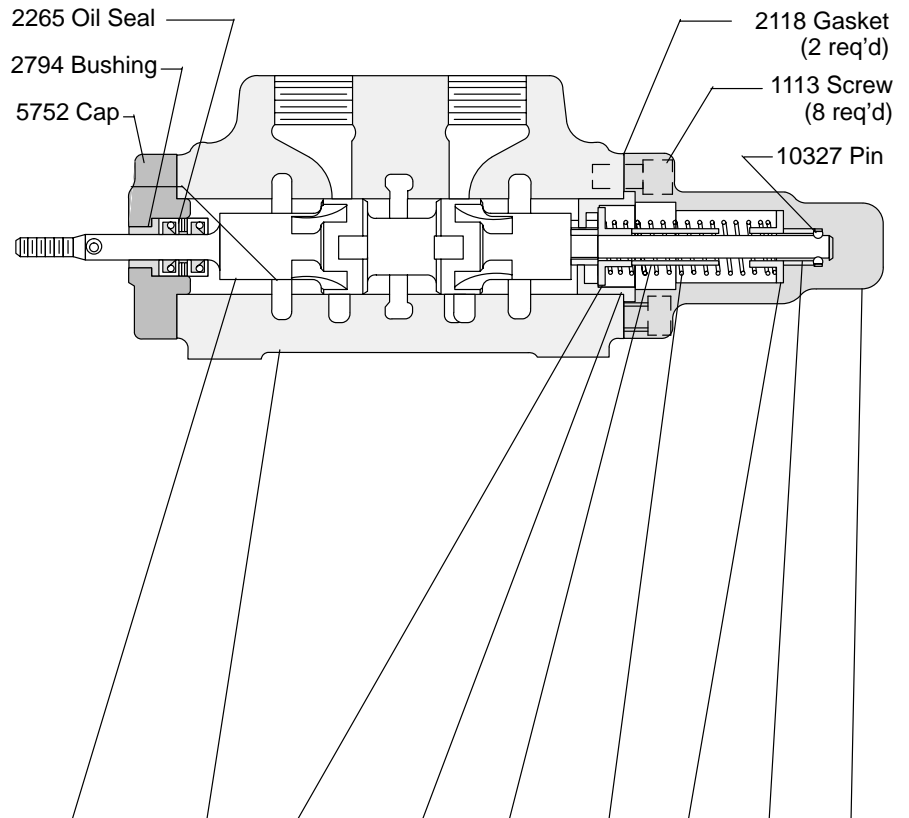

Model	Valve Spool					Body	Not Used on "NS" Models						
	Basic	S1	S2	S3	S4		Collar	Bushing	#Stop	Spring	Collar	Spacer	Cap
C-1430	76638	76640	76641	—	—	5701	5708	5709	38798 (See Note)	2980	5707	5749 (2 req'd)	5751
C-1432	76639	—	—	76642	76643								
C-1450	76638	76640	76641	—	—	17232							
C-1452	76639	—	—	76642	76643								

Note: Stop 38798 replaced by 35510 on suffix "X" models.

**C-434, C-1434, C-1454,
C2-1434, C2-1454**

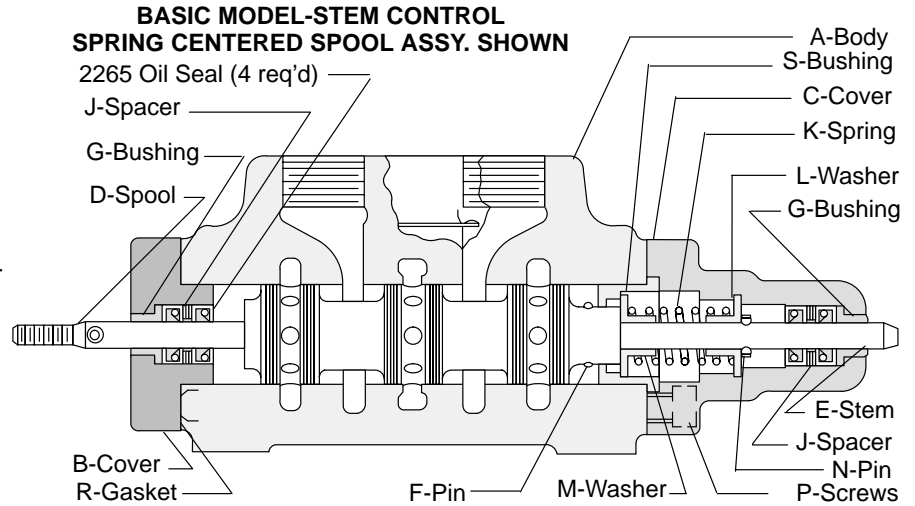
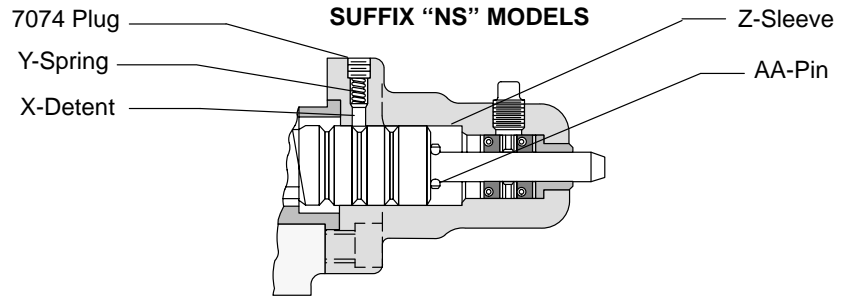
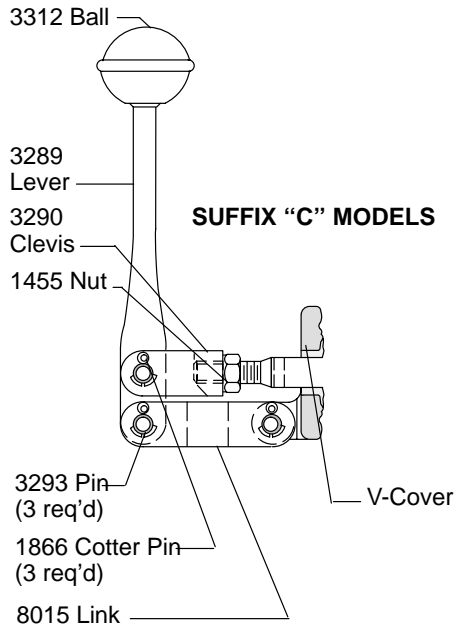

Part Letter and Name	Suffix Letter	No. Req'd.	C-434	C-1434	C-1454	C2-1434	C2-1454	Part Letter and Name	Suffix Letter	No. Req'd.	C-434	C-1434	C-1454	C2-1434	C2-1454
A Body	All	1	5646	5701	17232	5701	17232	M Washer	Except -NS	1	3353	5708	5708	—	—
B Cover	Except-C	1	3346	5702	5702	—	—	N Pin	Except -NS	1	10187	10327	10327	—	—
C Cover	Except -NS	1	3345	5703	5703	—	—	P Screws	All	8	1071	1113	1113	1113	1113
	-NS	1	5841	20666	20666	31477	31477		R Gasket	All	2	40191	2118	2118	2118
D Spool	Except -NS	1	3350	5705	5705	—	—	S Bushing	All	1	—	5709	5709	5709	5709
	-NS	1	19436	5705	5705	5705	5705		T Lever	-C	1	7156	10736	10736	10736
E Stem	Except -NS	1	—	5706	5706	—	—	V Cover	-C	1	7157	15163	15163	15163	15163
	-NS	1	—	20664	20664	5706	5706		X Detent	-NS	1	1937-X	19350	19350	19350
F Pin	All	1	—	12273	12273	12273	12273	Y Spring	-NS	1	2954	19467	19467	19467	19467
G Bushing	All	2	3355	2794	2794	2794	2794	X Sleeve	-NS	1	—	20665	20665	20665	20665
	Except -NS	1	2949	2953	2953	—	—		AA Pin	-NS	1	—	10327	10327	10327
J Spacer	All	2	3356	5465	5465	5465	5465								
K Spring	Except -NS	1	2949	2953	2953	—	—								
L Washer	Except -NS	1	3354	5707	5707	—	—								

Model Code

C (2) - (1)4* * - (*) - (*) - (S*)

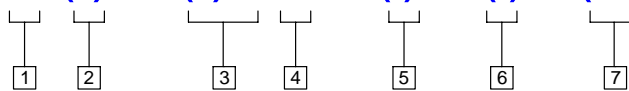

1 Model Series

C - Control valve

2 Design

2 - Second design

Omitted - Basic design

3 Port Sizes

47 - 3/8" NPT

43 - 3/4" NPT

141 - 1" NPT

143 - 1-1/4" NPT

145 - 1-1/2" NPT

4 Basic Spool

0 - Open center

2 - Closed center

4 - Tandem center

6 - Closed center

8 - Open center

5 Control

C - Lever

F - Treadle

Omitted - Stem

6 Positioning

A - Spring offset to extended position

B - Spring offset to retracted position

NS - No-spring, three position detent

Omitted - Spring centered

7 Special Features

Omitted - Standard

S* - Special

For satisfactory service life of these components, use full flow filtration to provide fluid which meets ISO cleanliness code 18/15 or cleaner. Selections from Eaton OFF, OFR and OFRS filter series are recommended.