

Vickers®

## Directional Controls

---



### Lever Operator Directional Control Valves

DG17S-8-\*\*-10

DG17S4-10 \*\*-50

NFPA D08/D10, ISO-4401-08/10

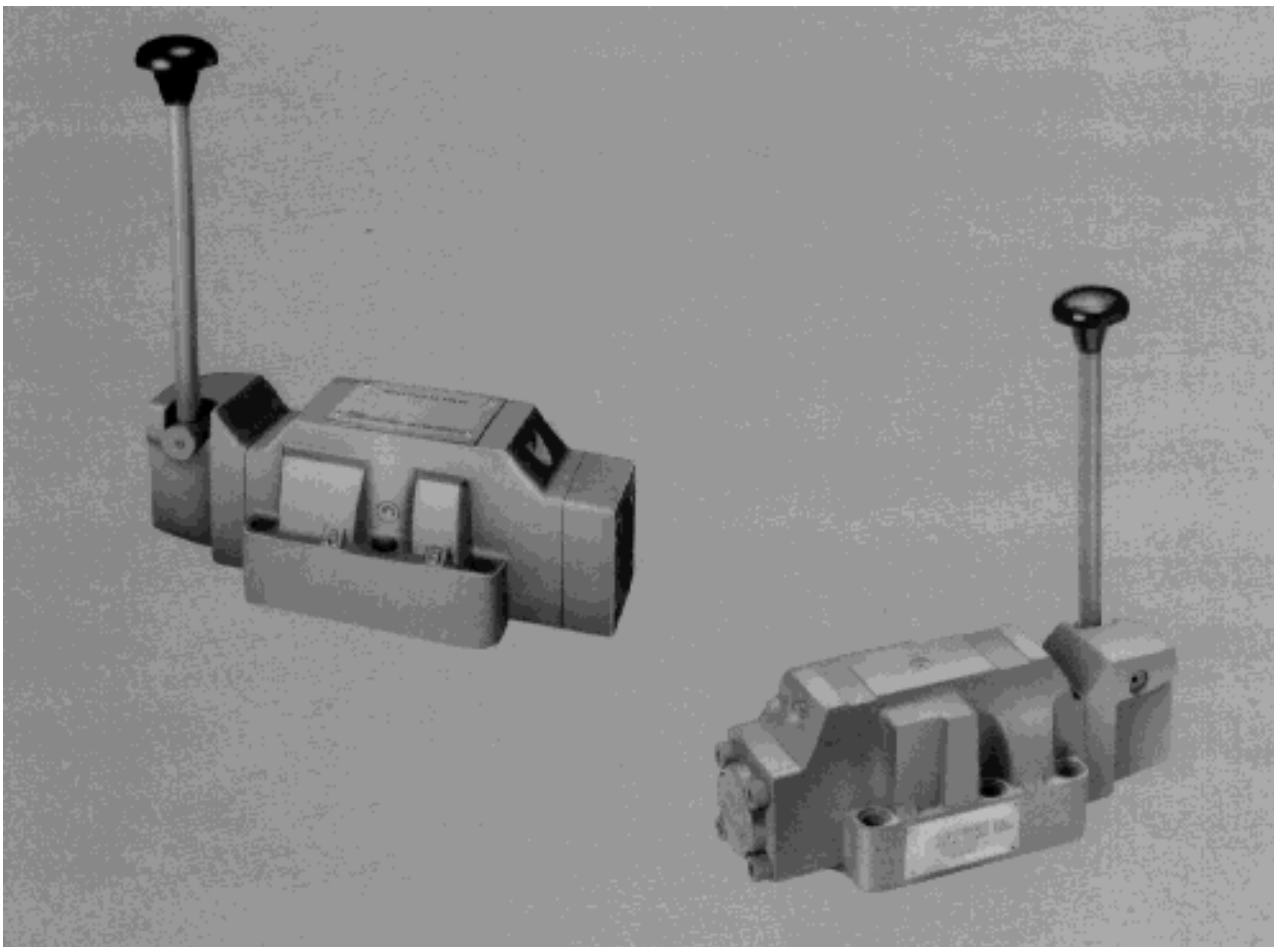

**VICKERS**

Released 5/94

# Table of Contents

---

General Information .....	4
DG17S-8 Basic Characteristics	
Installation Data	
Mounting Interface	
Shifting Action	
DG17S4-10 Basic Characteristics	
Mounting Interface	
Shifting Action	
Mounting Position	
Service Information	
Model Code DG17S-8 .....	5
DG17S-8 Maximum Flow Rating	
DG17S-8 Recommended Flow Rating .....	6
Oil Flow Directions	
DG17S-8 Pressure Drop .....	7
DG17S-8 Installation Dimensions .....	8
DG17S-8 Subplates & Bolt Kits .....	9
Model Code DG17S4-10 .....	10
DG17S-8 Maximum Flow Rating	
DG17S4-10 Pressure Drop .....	11
DG17S4-10 Installation Dimensions .....	12
DG17S4-10 Subplates & Bolt Kit .....	13
Application Data .....	14

# Introduction

---

## General Description

These valves are generally used to control the direction of flow in a hydraulic circuit. This, in turn, would control the direction of movement of a hydraulic cylinder, or the rotation of a fluid motor.

- DG17S-8 Lever Operated
- DG17S4-10 Lever Operated

## Features and Benefits

- Suitable for the most demanding industrial applications with flow capacities up to 380 l/min (100 USgpm) and rated pressure of 210 bar (3000 psi).
  - High pressure and flow capability for maximum cost-effectiveness.
  - Low shock characteristics to maximize machine life.
  - Solid cast body and core passages for maximum strength and minimal pressure drop.
  - Designed and backed by Vickers, with over 70 years as the global leader in fluid power and motion control.
-

# General Information

## DG17S-8 Basic Characteristics

Max. pressure: 210 bar (3000 psi)  
Max. flow: 380 l/min (100 USgpm)  
Max. pressure port T:  
..... 140 bar (2000 psi)  
Weight spring centered/detented:  
..... 13,5 kg (29.8 lbs.)  
Weight spring offset:  
..... 15 kg (33 lbs.)

## Installation Data

Drain connection must be piped directly to tank through a surge free line so there will be no back pressure at this port.

## Mounting Interface

ISO 4401-08  
NFFPA D08  
CETOP 8

Port connections are made by mounting valves on a subplate or manifold having mounting dimensions which conform to NFFPA-D08 (ISO-4401-08) pattern.

## DG17S4-10 Basic Characteristics

Max. pressure: 210 bar (3000 psi)  
Max. flow: 341 l/min (90 USgpm)  
Max. pressure port T:  
..... 210 bar (3000 psi)  
Weight: ..... 42,6 kg (94 lbs.)  
Weight (Subplate):  
..... 17,2 kg (38 lbs.)

The DG17, lever operated valves are ideally suited for applications requiring a manually operated, four-way directional valve.

## Mounting Interface

ISO 4401-10  
NFFPA D10

Port connections are made by mounting the valves on a subplate or manifold having mounting dimensions which conform to NFFPA-D10 (ISO-4401-10) pattern.

## Shifting Action

Spring offset valves are spring positioned unless lever is actuated. No-spring detented valves maintain the spool position last selected. Machine vibration, heat, improper circuitry and externally induced shocks may cause no-spring detented valves to shift prematurely.

Spring centered models return valve spool to center position by centering springs when lever pressure falls below minimum requirement.



## CAUTION

Surges of oil in a common tank line serving these and other valves can be of sufficient magnitude to cause inadvertent shifting of these valves. This is particularly critical in the no-spring detented type valves. Separate tank lines or a vented manifold with a continuous downward path to tank is necessary.

## Mounting Position

No-spring detented valves must be installed with the longitudinal axis horizontal for good machine reliability. The mounting position of spring-offset models is unrestricted.

Drain connection must be piped directly to tank through a surge free line so there will be no back pressure at this port.

## NOTE

Any sliding spool valve, if held for long periods of time, may stick and not spring return due to fluid residue formation and therefore, should be cycled periodically to prevent this from happening.

## Service Information

Refer to specific Vickers parts drawing for service parts information. A complete parts breakdown is contained in this drawing. Order by literature number.  
DG17S-8-\*A/C/N ..... I-3441-S  
DG17S-10-50 ..... I-3564-S

# Lever Operated Directional Valves

## Model Code

**DG17S - 8 - \*\* \* - 10 - LH**

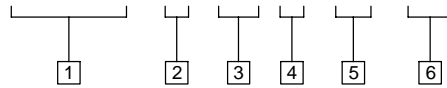

### 1 Directional Control

Manifold or subplate mounted; manual lever operated; 4-way flow direction. Rated pressure 210 bar (3000 psi).

### 3 Spool Types

0, 2, 3, 4, 6, 8, 33 - (See flow rating tabulations for descriptions.)

### 5 Design Number

Subject to change. Installation dimensions remain as shown for design numbers 10 through 19 models.

### 2 Interface

NFPA-D08 (ISO-4401-08)  
8 - Flow 380 l/min (100 USgpm)

### 4 Spool/Spring Arrangement

A - Spring offset  
C - Spring centered  
N - No-spring detented

### 6 Spring Offset Model

LH - Offset to B. (Omit for offset to A models shown.)

## DG17S-8 Max. Flow Rating

Model Code	70 bar (1000 psi)			140 bar (2000 psi)			210 bar (3000 psi)		
	Model -C-	Model -A-	Model -N-	Model -C-	Model -A-	Model -N-	Model -C-	Model -A-	Model -N-
	l/min (USgpm)	l/min (USgpm)	l/min (USgpm)	l/min (USgpm)	l/min (USgpm)	l/min (USgpm)	l/min (USgpm)	l/min (USgpm)	l/min (USgpm)
DG17S-8-0C-10 DG17S-8-0A-10 DG17S-8-0N-10	380 (100)	380 (100)	380 (100)	303 (80)	380 (100)	380 (100)	227 (60)	380 (100)	380 (100)
DG17S-8-2C-10 DG17S-8-2A-10 DG17S-8-2N-10	380 (100)	265 (70)	380 (100)	380 (100)	265 (70)	380 (100)	380 (100)	265 (70)	380 (100)
DG17S-8-3C-10 DG17S-8-3N-10	380 (100)	–	380 (100)	380 (100)	–	380 (100)	380 (100)	265 (70)	380 (100)
DG17S-8-4C-10 DG17S-8-4N-10	303 (80)	–	380 (100)	303 (80)	–	380 (100)	303 (80)	–	380 (100)
DG17S-8-6C-10 DG17S-8-6A-10 DG17S-8-6N-10	380 (100)	190 (50)	380 (100)	380 (100)	133 (35)	380 (100)	380 (100)	95 (25)	380 (100)
DG17S-8-8C-10 DG17S-8-8N-10	303 (80)	–	380 (100)	303 (80)	–	380 (100)	303 (80)	–	380 (100)
DG17S-8-33C-10 DG17S-8-33A-10 DG17S-8-33N-10	380 (100)	190 (50)	380 (100)	380 (100)	133 (35)	380 (100)	380 (100)	95 (25)	380 (100)

# DG17S-8 Flow Ratings

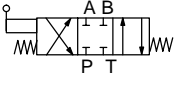
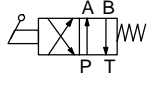
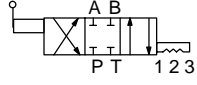
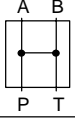
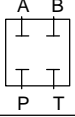
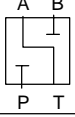
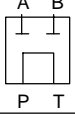
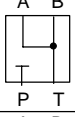
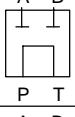
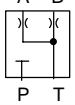
Spring Centered ▼ -C-	Spring Offset ▼ -A-	No-Spring Detented ▼ -N-	Standard Spool Types		Recommended Flow Capacity at 210 bar (3000 psi)
All Spools	0, 2, 6 & 33	All Spools			
			<b>Center Position &amp; Spool Type</b>	<b>Description Center Position</b>	l/min (USgpm)
DG17S-8-0C-10	DG17S-8-0A-10	DG17S-8-0N-10	"0" 	Opens to T all ports	170 (45)
DG17S-8-2C-10	DG17S-8-2A-10	DG17S-8-2N-10	"2" 	Closed to T all ports	170 (45)
DG17S-8-3C-10	—	DG17S-8-3N-10	"3" 	Closed P & B open A to T	170 (45)
DG17S-8-4C-10	—	DG17S-8-4N-10	"4" 	Tandem P to T closed crossover	170 (45)
DG17S-8-6C-10	DG17S-8-6A-10	DG17S-8-6N-10	"6" 	Closed P only open A & B to T	170 (45) - C & N 95 (25) - A
DG17S-8-8C-10	—	DG17S-8-8N-10	"8" 	Tandem P to T open crossover	170 (45)
DG17S-8-33C-10	DG17S-8-33A-10	DG17S-8-33N-10	"33" 	Closed P open A & B to T over tapers	170 (45)

→ Full flow

▼ See Direction of Flow Chart, next page.

■ Center position applies to:

1. Spring centered models and no-spring detented models at intermediate position #2.
2. Spring offset models at center crossover.

↔ Restricted flow

## Direction of Oil Flow for Lever Positions

Spool Type	Position No. 1 (Extreme Out)	Position No. 3 (Extreme In) Normal for Spring Offset
0, 2, 3, 6, 33	Pr. → Cyl. B Cyl. A → Tank	Pr. → Cyl. B Cyl. A → Tank
4 & 8	Pr. → Cyl. A Cyl. B → Tank	Pr. → Cyl. B Cyl. A → Tank

# DG17S-8 Pressure Drop

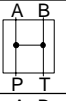
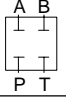
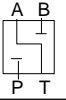
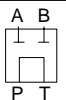
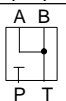
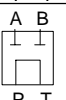
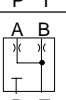
Spool Type & Center Position	P → A	B → T	P → B	A → T	P → T on Center
"0" 	2	3	2	2	1
"2" 	3	4	3	2	-
"3" 	3	4	3	2	-
"4" 	6	6	6	6	5
"6" 	3	3	3	2	-
"8" 	2	5	2	5	4
"33" 	3	4	3	2	-

**Example:**

Find the pressure drop from P → B for type 2 spool. Using the table above find numeral 2 in spool type column. To the right of numeral 2, find the reference curve number 3 under P → B column. The pressure drop from P → B for type 2 spool would be obtained on curve number 3.

1. Pressure drop curves give approximate pressure drop ( $\Delta P$ ) when passing 21 cSt (100 SUS) fluid(s) having .865 specific gravity.
2. For any other viscosity(s), the pressure drop ( $\Delta P$ ) will change as follows:

Viscosity	14	32	43	54	65	76	86
cSt	14	32	43	54	65	76	86
(SUS)	(75)	(150)	(200)	(250)	(300)	(350)	(400)
% of $\Delta P$ (Approx.)	93	111	119	126	132	137	141

3. For any other specific gravity ( $G_1$ )\*, the pressure drop ( $\Delta P_1$ ), will be approximately:

$$\Delta P_1 = \Delta P(G_1/G)$$

\* Specific gravity of fluid may be obtained from its producer. The value is higher for fire-resistant fluids than for oil.

## Pressure vs. Flow Curves

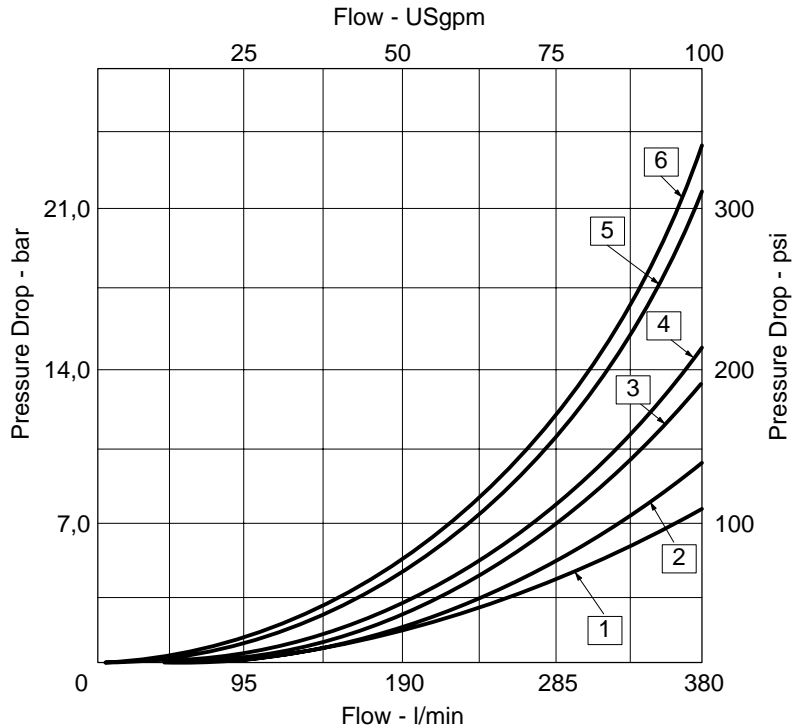

# DG17S-8 Installation Dimensions

## Lever Operated Spring Centered DG17S-8-\*C-10 No-Spring Detented DG17S-8-\*N-10

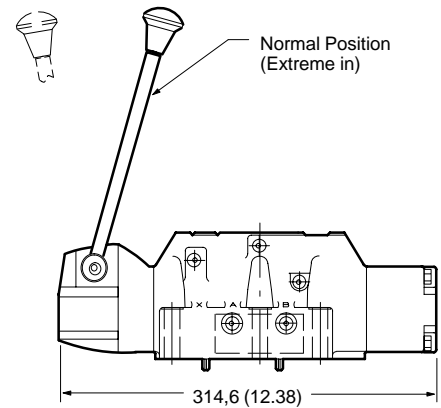
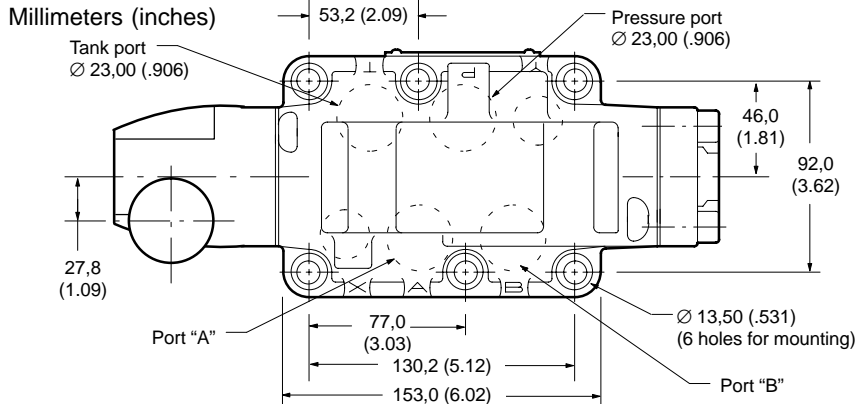

**Spring Offset Model  
DG17S-8-\*A-10**

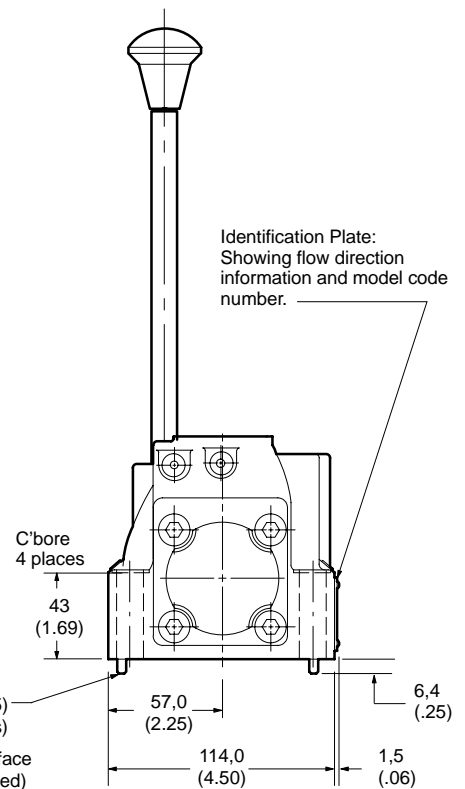
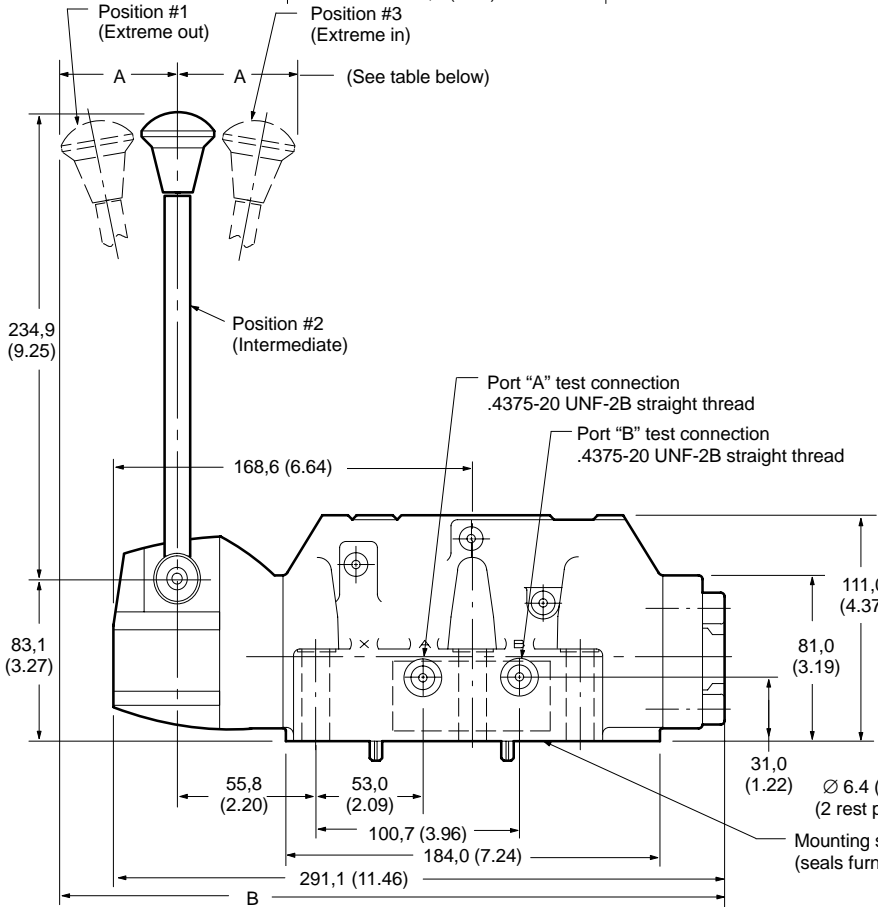

Spool	Dimension A	Dimension B	* Force (approx.) kg (lbs.)
0	79,5 (3.13)	334,4 (13.16)	6,8 (15)
2, 3, 6, 33	79,5 (3.13)	334,4 (13.16)	9,1 (20)
4, 8	96,0 (3.78)	350,9 (13.82)	11,3 (25)

\* At recommended flow and maximum operating pressure.



# DG17S-8 Subplates & Bolt Kits

Valves, subplates and mounting bolts must be ordered separately.

When subplate is not used, a machined pad must be provided for mounting. Pad must be flat within 0,0127 mm (.0005 inch) and smooth within 1,6 µm (63 microinch). Mounting bolts, when provided by customer, should be SAE grade 7 or better.

Example:

- (1) DG17S-8-2C-10 Valve
- (1) DGSM-8-10-T12 Subplate
- (1) BKDG06-635 Inch Bolt Kit or
- (1) BKDG8-655M Metric Bolt Kit

## DGSM-8-10-T12/16 Mounting Subplates

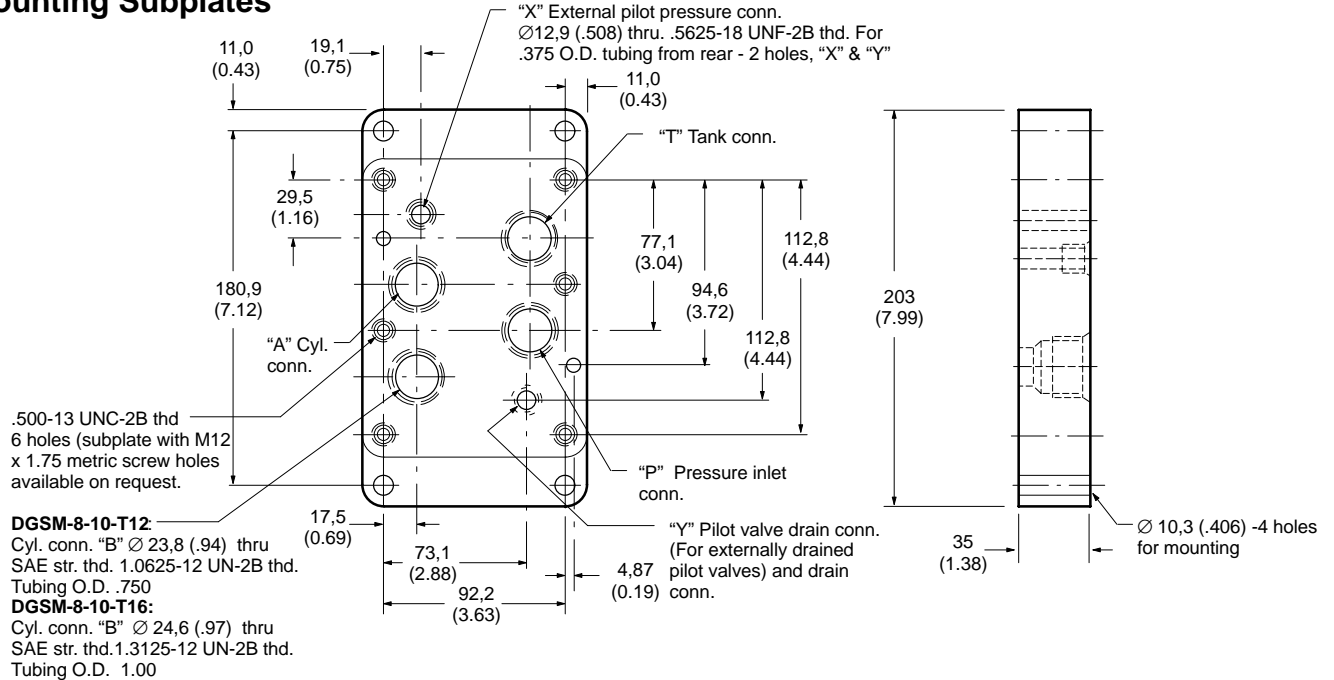

## DGSM-8-10-T20 Mounting Subplate

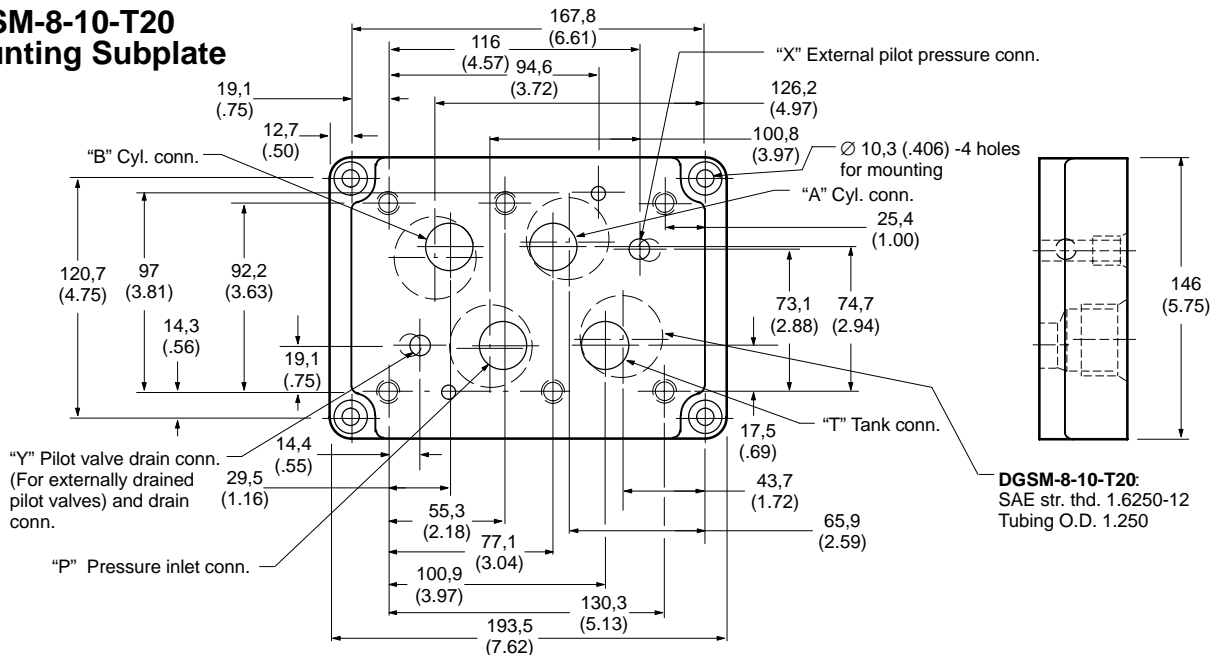

# Lever Operated Directional Valve

## Model Code

**D G 17 S 4 -10 \*\* C 5\* - LH**

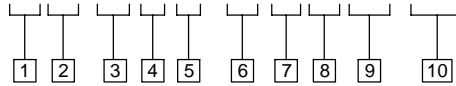

<b>1 Directional Control</b>	<b>5 Flow Direction</b>	<b>8 Spool/Spring Arrangement</b>
<b>2 Mounting Type</b> G - Manifold or Subplate	4 - Four-way - spring offset model only	A - Spring offset C - Spring centered N - No-spring, detented
<b>3 Valve Operator</b> 17 - Manual lever operated	<b>6 Valve Size</b> 10 - ISO-4401-10, NFPA-D10 interface	<b>9 Design Number</b> Subject to change. Installation dimensions remain as shown for design numbers 50 through 59. -50 Design has top located nameplate. -53 Design has 1/4" NPT test ports.
<b>4 Sliding Spool</b>	<b>7 Spool Type</b> 0, 2, 4, 6, 8, 33	<b>10 Left Hand</b> Blank - Omit if not required.

## Flow Direction & Rating

Model Numbers			Spool Type	Flows l/min (USgpm) @ 210 bar (3000 psi)	Direction of oil flow for valve spool position		
No Spring Detented N	Spring Centered C	Spring Offset A			#2 Intermediate	#3 Extreme in	#1 Extreme out
DG17S4-100N	DG17S4-100C	DG17S4-100A	0 - Open center all ports	284 (75)	Press. Port A & Port B → Tank	Press. → Port A Port B → Tank	Press. → Port B Port A → Tank
DG17S-102N	DG17S4-102C	DG17S4-102A	2 - Closed center all ports	341 (90)	Press. Port A & Port B Blocked		
-	DG17S4-104C	-	4 - Tandem Closed crossover	189 (50)	Press. → Tank Port A & Port B blocked	Press. → Port B Port A → Tank	Press. → Port A Port B → Tank
DG17S4-106N	DG17S4-106C	DG17S4-106A	6 - Closed center P only	341 (90)	Press. Blocked Port A & Port B → Tank	Press. → Port A Port B → Tank	Press. → Port B Port A → Tank
-	DG17S4-108C	-	8 - Tandem Open crossover	189 (50)	Press. → Tank Port A & Port B blocked	Press. → Port B Port A → Tank	Press. → Port A Port B → Tank
-	DG17S4-1033C	-	33 - Closed center Bleed A & B	341 (90)	Press. Blocked Port A & Port B → Tank	Press. → Port A Port B → Tank	Press. → Port B Port A → Tank

# DG17S4-10 Model Series

## Functional Symbols

Spring offset - A

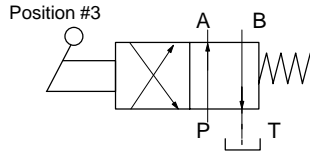

No-spring - Detented N

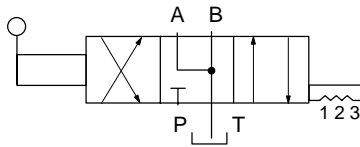

Spring centered - C

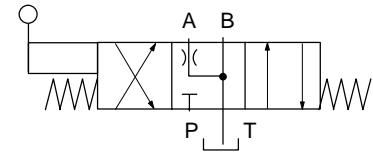

## Pressure Drop

Spool Type	P to A	B to T	P to B	A to T	P to T Centered
0	3,2 bar (47 psi)	4,2 bar (61 psi)	3,0 bar (44 psi)	4,6 bar (67 psi)	3,5 bar (51 psi)
2	2,5 bar (36 psi)	3,8 bar (55 psi)	2,7 bar (38 psi)	3,7 bar (53 psi)	—
4	4,1 bar (60 psi)	8,3 bar (120 psi)	5,5 bar (80 psi)	9,2 bar (134 psi)	3,7 bar (54 psi)
6	2,3 bar (34 psi)	2,2 bar (32 psi)	2,6 bar (37 psi)	2,1 bar (30 psi)	—
8	3,5 bar (51 psi)	8,1 bar (118 psi)	3,9 bar (57 psi)	8,9 bar (129 psi)	3,6 bar (52 psi)
33	2,5 bar (36 psi)	3,7 bar (53 psi)	2,7 bar (38 psi)	3,5 bar (51 psi)	—

1. Figures in the pressure drop chart give approximate pressure drops ( $\Delta P$ ) when passing 379 l/min (100 USgpm) flow (Q) of 100 SUS fluid(s) having .865 specific gravity.

2. For any other flow rate ( $Q_1$ ), the pressure drop ( $\Delta P_1$ ) will be approximately:

$$\Delta P_1 = \Delta P(Q_1/Q_2)^2$$

3. For any other viscosity(s), the pressure drop ( $\Delta P$ ) will change as follows:

Viscosity							
cSt	14	32	43	54	65	76	86
(SUS)	(75)	(150)	(200)	(250)	(300)	(350)	(400)
% of $\Delta P$ (Approx.)	93	111	119	126	132	137	141

4. For any other specific gravity ( $G_1$ )\*, the pressure drop ( $\Delta A_1$ ), will be approximately:

$$\Delta P_1 = \Delta P(G_1/G)$$

\* Specific gravity of fluid may be obtained from its producer. The value is higher for fire-resistant fluids than for oil.

# DG17S4-10 Installation Dimensions

## Lever Operated Directional Valves Spring Offset, Spring Centered & Detented

- Four-way Spring Centered - DG17S4-10\*C-5\*
- Four-way No Spring w/Detent - DG17S4-10\*N-5\*
- Four-way Spring Offset† - DG17S-10\*A-5\*

Millimeters (inches)

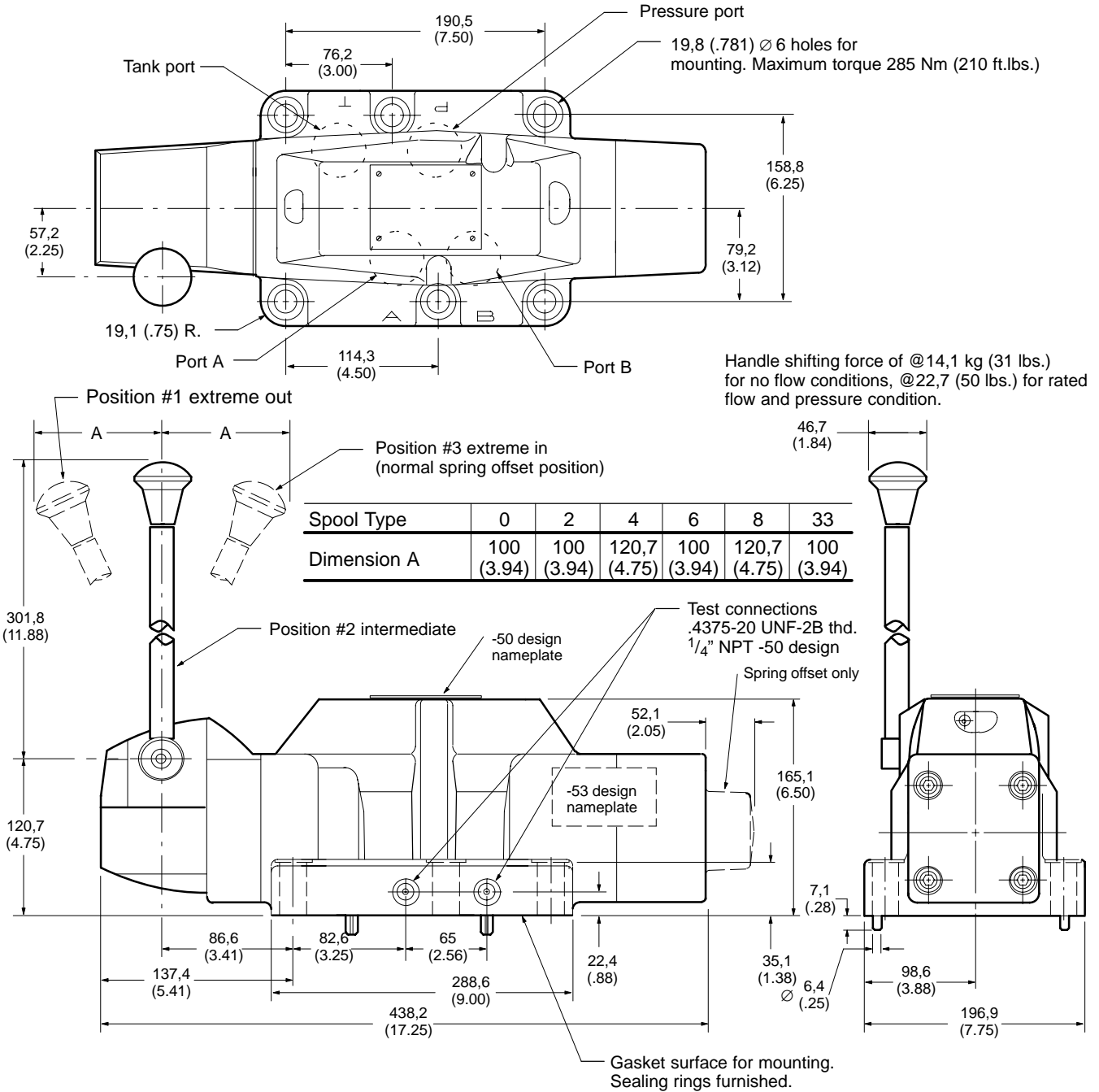

† Offset models have an internal spring which returns the spool when the lever is released.

# DG17S4-10 Subplates & Bolt Kit

Valves, subplates and mounting bolts must be ordered separately.

Example:

One (1) DG17S4-102C-5\* Valve  
 One (1) BKDG10-636 Bolt Kit

When subplate is not used, a machined pad (as indicated by subplate shaded area, below, must be provided for mounting. Pad must be flat within 0,0127 mm (.0005 inch) and smooth within 1,6 µm (63 microinch). Mounting bolts, when provided by customer, should be SAE grade 7 or better.

## Mounting Subplate DGSM-10(\*) -11

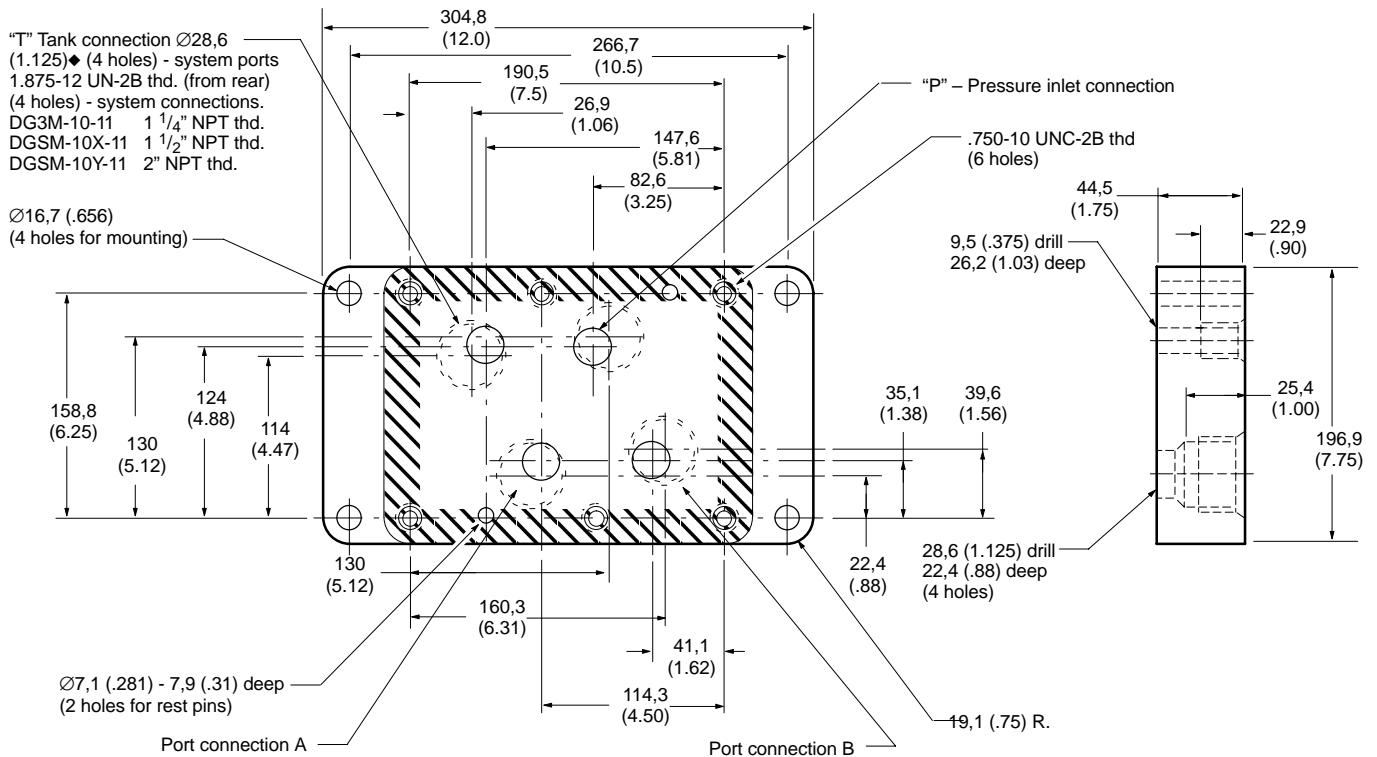

◆ Manifolds or other mounting interface can be drilled to 33,3 (1.312) dia. Fitting size and fitting spacing limit the subplate port size to 28,6 (1.125) dia.

# Application Data

## Fluid Cleanliness

Proper fluid condition is essential for long and satisfactory life of hydraulic components and systems. Hydraulic fluid must have the correct balance of cleanliness, materials, and additives for protection against wear of components, elevated viscosity, and inclusion of air.

Essential information on the correct methods for treating hydraulic fluid is included in Vickers publication 561 "Vickers Guide to Systemic Contamination Control" available from your local Vickers distributor or by

contacting Vickers, Incorporated. Recommendations on filtration and the selection of products to control fluid condition are included in 561.

Recommended cleanliness levels, using petroleum oil under common conditions, are based on the highest fluid pressure levels in the system and are coded in the chart below. Fluids other than petroleum, severe service cycles, or temperature extremes are cause for adjustment of these cleanliness codes. See Vickers publication 561 for exact details.

Vickers products, as any components, will operate with apparent satisfaction in fluids with higher cleanliness codes than those described. Other manufacturers will often recommend levels above those specified. Experience has shown, however, that life of any hydraulic component is shortened in fluids with higher cleanliness codes than those listed below. These codes have been proven to provide a long, trouble-free service life for the products shown, regardless of the manufacturer.

Product	System Pressure Level bar (psi)		
	<70 (<1000)	70-210 (1000-3000)	210+ (3000+)
Vane Pumps – Fixed	20/18/15	19/17/14	18/16/13
Vane Pumps – Variable	18/16/14	17/15/13	
Piston Pumps – Fixed	19/17/15	18/16/14	17/15/13
Piston Pumps – Variable	18/16/14	17/15/13	16/14/12
<b>Directional Valves</b>	<b>20/18/15</b>	<b>20/18/15</b>	<b>19/17/14</b>
Pressure/Flow Control Valves	19/17/14	19/17/14	19/17/14
CMX Valves	18/16/14	18/16/14	17/15/13
Servo Valves	16/14/11	16/14/11	15/13/10
Proportional Valves	17/15/12	17/15/12	15/13/11
Cylinders	20/18/15	20/18/15	20/18/15
Vane Motors	20/18/15	19/17/14	18/16/13
Axial Piston Motors	19/17/14	18/16/13	17/15/12
Radial Piston Motors	20/18/14	19/17/13	18/16/13

## Fluids and Seals

Fluorocarbon seals are standard and are suitable for use with phosphate ester type fluids or their blends, water glycol, water-in-oil emulsion fluids and petroleum oil.