

Air Controlled Pilot Operated Directional Valves

DG19S-10-**-*-53
DG19S-H8-**-50

DG19S4-10-**-M-70

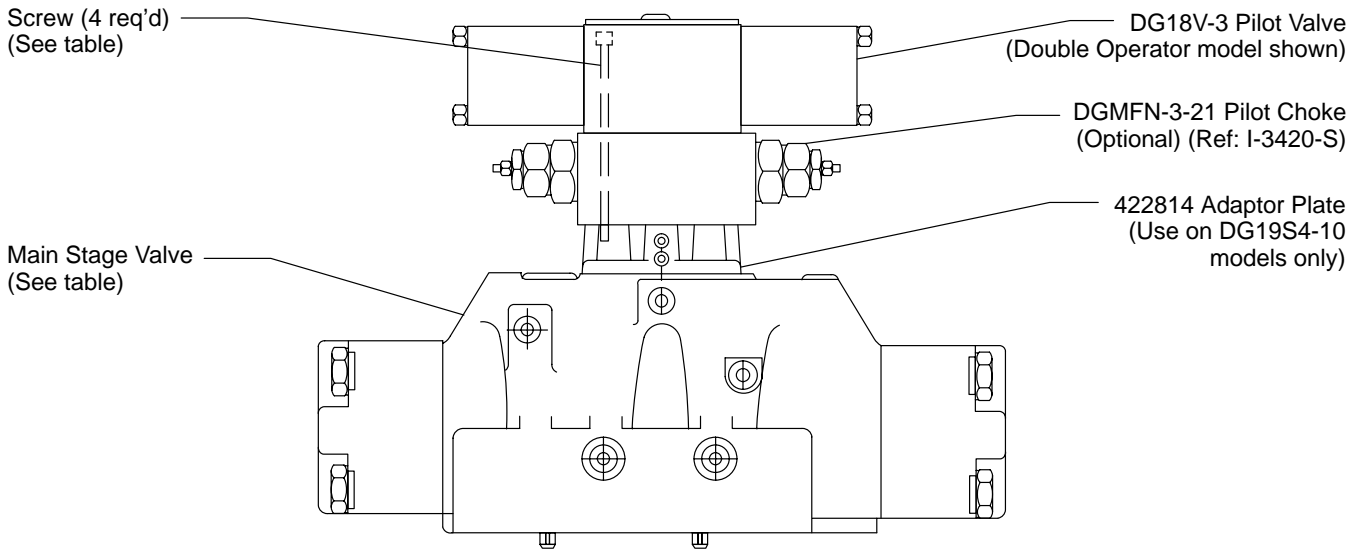

| Model | Screw (4 req'd) (w/o Pilot choke) | Screw (4 req'd) (with Pilot choke) | Screw Torque |
|------------------|--------------------------------------|---------------------------------------|-------------------------------|
| DG19S-8-**-20 | 473732 | 417413 | 4.5-5.7 N.m (40-50 lb.in.) |
| DG19S-H8-**-50 | | | |
| DG19S4-10**-M-70 | 10932 | 207900 | |

| For Models Listed Below | Use Main Stage Portion Of DG5S Valve | DG5S Parts Drwg. | And Air Controlled DG18V-3-**-40 Pilot Valve | DG18V-3 Parts Drwg. |
|-------------------------|--------------------------------------|------------------|--|---------------------|
| DG19S-8-*A-20 | DG5S4-8-*A-**-20 | I-3869-S | DG18V-3-2A-40 | I-3616-S |
| DG19S-8-4/8A-20 | DG5S4-8-4/8A-**-20 | | DG18V-3-28A-40 | |
| DG19S-8-*B-20 | DG5S4-8-*B-**-20 | | DG18V-3-6B-40 | |
| DG19S-8-4/8B-20 | DG5S4-8-4/8B-**-20 | | DG18V-3-68BL-40 | |
| DG19S-8-*C-20 | DG5S4-8-*C-**-20 | | DG18V-3-6C-40 | |
| DG19S-8-4/8C-20 | DG5S4-8-4/8C-**-20 | | DG18V-3-68C-40 | |
| DG19S-8-*F-20 | DG5S4-8-*F-**-20 | | DG18V-3-6F-40 | |
| DG19S-8-4/8F-20 | DG5S4-8-4/8F-**-20 | | DG18V-3-68F-40 | |
| DG19S-8-*N-20 | DG5S4-8-*C-**-20 | | DG18V-3-6N-40 | |
| DG19S-8-4/8N-20 | DG5S4-8-4/8C-**-20 | | DG18V-3-68N-40 | |
| DG19S-8-*D-20 | DG5S4-8-*D-**-20 | | DG18V-3-7F-40 | |
| DG19S-8-4/8D-20 | DG5S4-8-4/8D-**-20 | DG18V-3-78F-40 | | |

| For Models Listed Below | Use Main Stage Portion Of DG5S Valve | DG5S Parts Drwg. | And Air Controlled DG18V-3-**-40 Pilot Valve | DG18V-3 Parts Drwg. |
|-------------------------|--------------------------------------|------------------|--|---------------------|
| DG19S-H8-*A-50 | DG5S-H8-*A-**-50 | I-3868-S | DG18V-3-2A-40 | I-3616-S |
| DG19S-H8-4/8A-50 | DG5S-H8-4/8A-**-50 | | DG18V-3-28A-40 | |
| DG19S-H8-*B-50 | DG5S-H8-*B-**-50 | | DG18V-3-6B-40 | |
| DG19S-H8-4/8B-50 | DG5S-H8-4/8B-**-50 | | DG18V-3-68BL-40 | |
| DG19S-H8-*C-50 | DG5S-H8-*C-**-50 | | DG18V-3-6C-40 | |
| DG19S-H8-4/8C-50 | DG5S-H8-4/8C-**-50 | | DG18V-3-68C-40 | |
| DG19S-H8-*F-50 | DG5S-H8-*F-**-50 | | DG18V-3-6F-40 | |
| DG19S-H8-4/8F-50 | DG5S-H8-4/8F-**-50 | | DG18V-3-68F-40 | |
| DG19S-H8-*N-50 | DG5S-H8-*C-**-50 | | DG18V-3-6N-40 | |
| DG19S-H8-4/8N-50 | DG5S-H8-4/8C-**-50 | | DG18V-3-68N-40 | |
| DG19S4-10*A-M-70 | DG5S4-10*A-M-70 | I-3870-S | DG18V-3-2A-40 | |
| DG19S4-10*A-M-70 | DG5S4-104/8A-M-70 | | DG18V-3-28A-40 | |
| DG19S4-10*B-M-70 | DG5S4-10*B-M-70 | | DG18V-3-6B-40 | |
| DG19S4-104/8B-M-70 | DG5S4-104/8B-M-70 | | DG18V-3-68BL-40 | |
| DG19S4-10*C-M-70 | DG5S4-10*C-M-70 | | DG18V-3-6C-40 | |
| DG19S4-104/8C-M-70 | DG5S4-104/8C-M-70 | | DG18V-3-68C-40 | |
| DG19S4-10*N-M-70 | DG5S4-10*C-M-70 | | DG18V-3-6N-40 | |
| DG19S4-104/8N-M-70 | DG5S4-104/8C-M-70 | | DG18V-3-68N-40 | |
| DG19S4-10*D-M-70 | DG5S4-10*D-**-53 | I-3625-S | DG18V-3-7F-40 | |
| DG19S4-104/8D-M-70 | DG5S4-104/8D-**-53 | | DG18V-3-78F-40 | |

Model Code

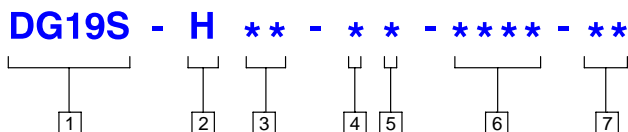

1 Model Series

DG19S - Air controlled, pilot operated directional valve

2 High Flow

(Omit on standard models)

H

3

Interface

- 8** - NFPA-D08 (ISO-4401-08)
- 10** - NFPA-D10 (ISO-4401-10)

4 Main Stage Spool Type

5 Spool/Spring Arrangement

- A** - Spring offset
- B** - Spring Centered, Operator "A" Removed
- C** - Spring Centered
- D** - Pressure Centered (8 & 10 size only)
- F** - Spring Offset, Shift to Center
- N** - No Spring Detented

6 Main Stage Options

(Refer to DG5S Parts Drwg.)

7 Design

For satisfactory service life of these components, use full flow filtration to provide fluid which meets ISO cleanliness code 18/15 or cleaner. Selections from Eaton OFF, OFR and OFRS filter series are recommended.

Printed in U.S.A.