

Eaton's RTU upgrade solution The SMP IO-2230 system



Eaton's cybersecure, reliable and cost effective RTU upgrade solution using the SMP IO-2230 system

Eaton's latest solution for RTU replacement provides utilities with a cost-effective answer to upgrading legacy RTUs with cybersecurity at the uppermost in mind.

Based on the utility hardened and proven Eaton's SMP family of substation automation products, the SMP Gateway automation platform and the SMP IO-2230 distributed I/O platform, our basic hardware agnostic replacement solution, supports most legacy RTU configurations.

The automation platform

Both Eaton's SMP Gateway automation platform models are substation-grade gateways with a proven history in data acquisition and distribution automation applications, as protocol conversion device and integration solution for secure IED remote access. They are recognized as one of the most efficient and reliable automation platforms on the market and are perfect for distributed automation.

The SMP IO-2230 platform

The SMP IO-2230 is Eaton's latest generation of substation-grade distributed I/O platforms which is fully integrated with the SMP Manager and Tools application for device configuration and maintenance. It integrates seamlessly with the automation platform—simplifying both system setup and commissioning.

The SMP IO-2230 uses a template-driven configuration tool, SMP Config, and includes numerous cybersecurity features to help utilities meet their compliance requirements, including NERC CIP (certified under UL 2900-2-2).

Advantages of Eaton's solution

- Eaton's replacement solution is easily adaptable to any specific RTU deployment scenario (e.g. GE D20)
- Hardware-agnostic solution adapted to various RTU configurations (3U rack space)
- Flexible upgrade options using Eaton's SMP Gateway automation platform, SMP IO-2230 distributed I/O units and adapted chassis while keeping existing wiring
- Not changing the field wiring allows for great cost savings on field installation man-hours and service interruptions
- Fast and efficient system integration using the advanced SMP Gateway HMI's Commissioning Tool, SMP Trace and other functionalities
- Simplified pre-loading operation of existing configuration into the SMP Gateway prior to installation
- Use of open industry protocols: standard DNP3, Goose messaging and IEC 61850, over a TCP/IP or RS-485 link
- Expansion capabilities with SMP distributed I/O units or other IEDs (with over 80 protocols supported)
- Available in rackmount



Integration services

Eaton's Electrical Engineering Services & Systems (EESS) provides turnkey services to run your project efficiently and on schedule for your entire legacy RTU replacement project.

- Substation design & drawings per utility standards
- Complete project management
- Installation & commissioning services with on-site supervision
- Standardized documentation practices including scheduling, reporting and project closeout

EATON

Powering Business Worldwide

Eaton's replacement solution

- With Eaton's solution, the legacy RTU main controller and I/O peripherals are removed and replaced with:
 - One (1) SMP Gateway automation platform (SMP SG-4250 or SMP SG-4260)
 - SMP IO-2230 units, each inserted in a chassis, to match the legacy RTU I/O functionality
- Interposing relays are kept (when present) for control outputs
- Legacy RTU connectors are simply transferred to the front of Eaton's chassis, allowing for the use of existing terminal cables and field wiring
- Power supply, IRIG-B, RS-485 and Ethernet connectors are located at the back of the chassis, directly on the SMP IO-2230 platform

This solution is adaptable to various RTU configurations and fits into a 3U rack space for each I/O module replacement. It provides seamless field integration of the SMP IO-2230 system and the SMP Gateway automation platform.

Available models (rackmount)

Model	I/Os
SMP IO-2230-A	32 AI
SMP IO-2230-K	32 BO
SMP IO-2230-S	64 BI

Benefits of Eaton's replacement solution

- The solution includes two substation-grade SMP devices (only the chassis is not substation-grade)
- Evolutive platform with regular software updates, bringing new features to the system
- 70% labor cost reduction compared to a traditional RTU replacement solution due to the use of existing wiring
- Minimum substation outage time required for the replacement
- Numerous cybersecurity features integrated into the SMP IO-2230 system to help meet NERC CIP requirements, to secure IED remote access and to enhance SCADA communication links
- All system components digitally signed
- Integrated firewall
- Advanced operational and non-operational data management capabilities
- Seamless I/O integration between the SMP Gateway and SMP IO-2230 unit
- Enhanced automation capabilities using the IEC 61131-3 Soft PLC of the SMP Gateway and/or the micro-PLC of the SMP IO-2230 unit
- Accurate IRIG-B time stamping
- Available turnkey services to manage your replacement project

Eaton's replacement solution

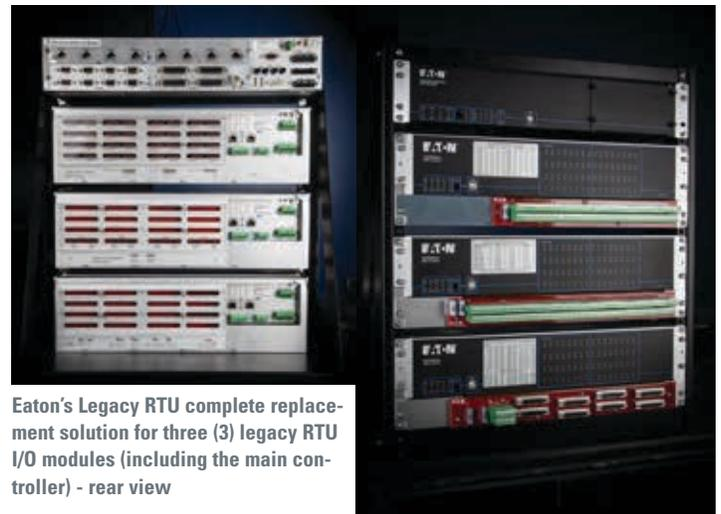
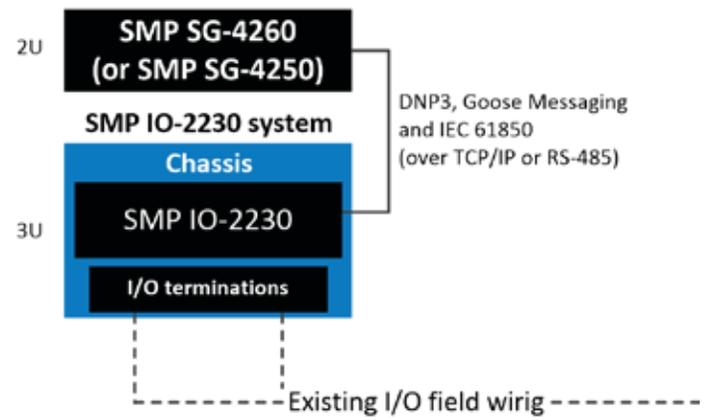

Eaton's Legacy RTU complete replacement solution for three (3) legacy RTU I/O modules (including the main controller) - rear view

Eaton's Legacy RTU complete replacement solution for three (3) legacy RTU I/O modules (including the main controller) - front view.

Example of Eaton's replacement solution mapped to a specific GE D20 setup

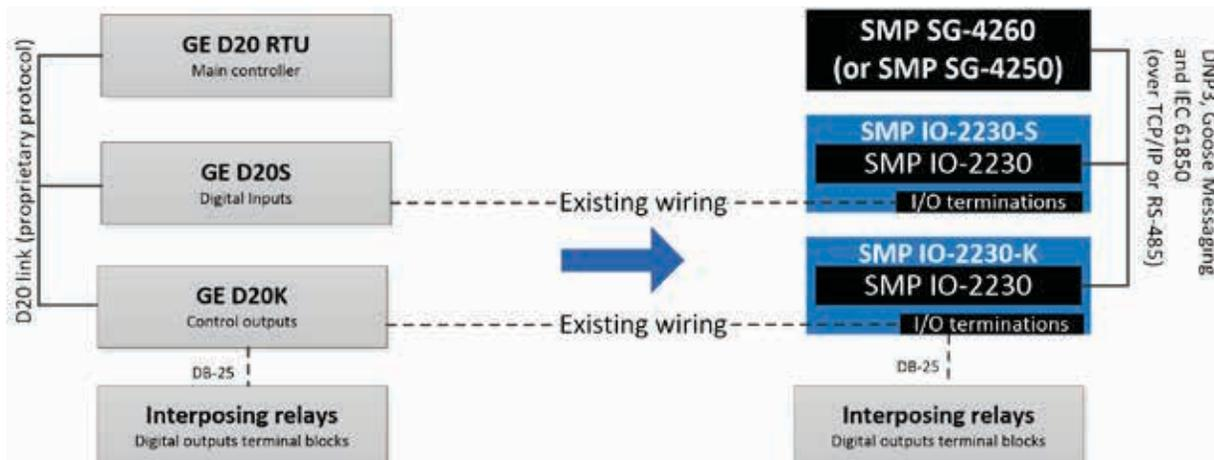

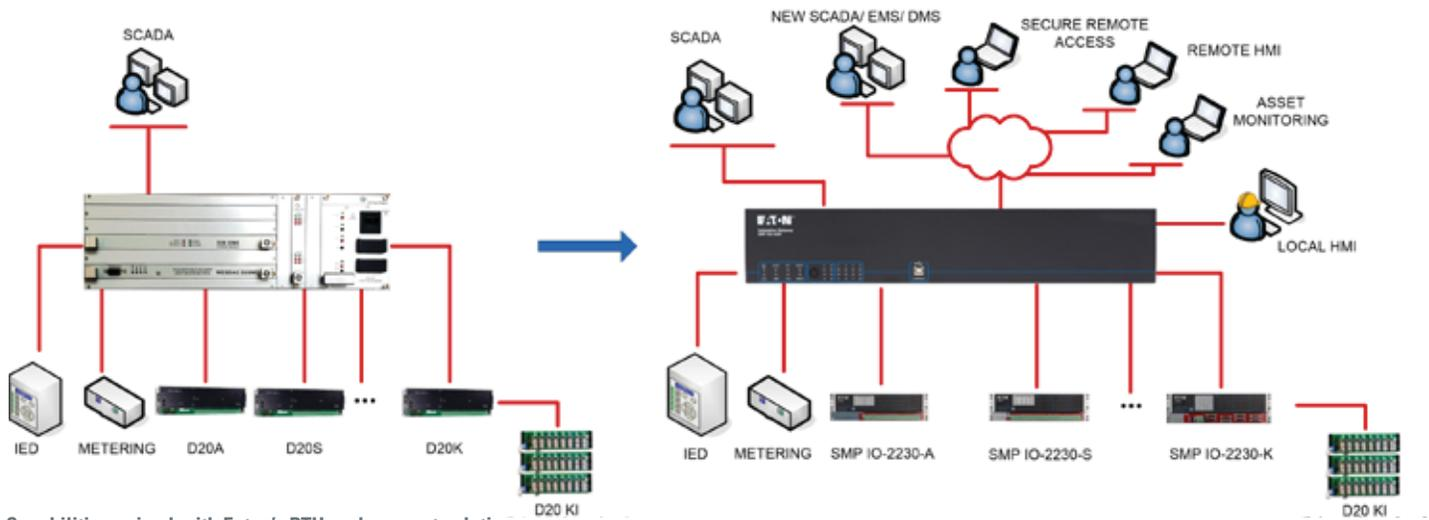

Capabilities gained with Eaton's RTU replacement solution

Getting even more from the SMP Gateway automation platform

When the SMP Gateway is associated with Eaton's Visual T&D solution and IED Manager Suite (IMS), utilities benefit from an even more powerful tool.

Visual T&D

As an alternative to SCADA, Visual T&D is an easy-to-use, pre-configured and scalable smart monitoring and control application that continuously monitors substation and distribution equipment operation and performance. Visual T&D automatically imports all SMP Gateway data points and supports redundant networks; it brings:

- Strong HMI features

- Perfect synergy with the SMP Gateway
- SCADA features (multiple data source and encrypted communication links)
- Centralized authentication and single sign-on
- Possibility of exportation to a Syslog server

IED Manager Suite (IMS)

IED Manager Suite is the complement to the SMP Gateway and Visual T&D systems. IMS takes care of the non-operational data management; it is used to provide automated fleet management and includes

the following features and capabilities:

- Allows IED inventory
- Provides secure remote access (auto-login, command filtering)
- Manages device configuration settings (monitoring changes)
- Manages password updates
- Manages firmware updates for SMP Gateways, CBC-8000 capacitor bank controllers and GridAdvisor Series II smart sensors and other devices (devices are integrated on a regular basis)
- Retrieves faults records, SOE and oscillography

- Manages communication with substation and IEDs
- Provides authentication and authorization services (active directory)
- Provides built-in reports (can be customized) for operation and compliance

SMP SC-2200 computing platform

The aforementioned software applications can be installed on Eaton's reliable substation-grade SMP SC-2200 computer, which is specially designed for mission-critical applications in harsh environments. This computer can host a virtual infrastructure and supports several hardware RAID configurations (substation-grade).

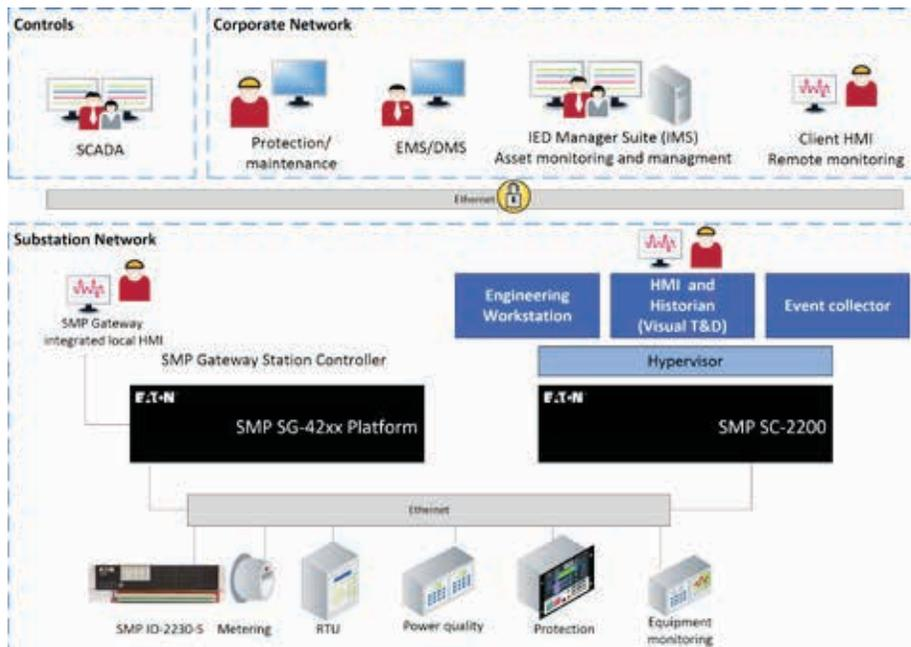

Additional capabilities of the SMP Gateway with Visual T&D and IMS

For more information, call: **1-800-815-2258**
or visit us at Eaton.com/smartgrid

Eaton
1000 Eaton Boulevard
Cleveland, OH 44122
United States
Eaton.com

**Eaton's Energy Automation Solutions
Division**

3033 Campus Drive, Suite 350N
Minneapolis, MN 55441
United States
Eaton.com/smartgrid

© 2019 Eaton
All Rights Reserved
Printed in USA
Publication No. PA912009EN
June 2019

Eaton is a registered trademark.

GE is a trademark of General Electric
Company

All other trademarks are property
of their respective owners.

Follow us on social media to get the
latest product and support information.

