

Eaton Fuller[®] Heavy-Duty Transmissions

TRDR0670 EN-US

June 2014

RTLO 1X713A Series
RTLO XX913A Series
RTLO 1X713A-T2 Series
RTLO XX913A-T2 Series



Powering Business Worldwide

BACKED BY

Roadranger

SUPPORT

Reference Numbers

Tag Information

Transmission model designation and other transmission identification information are stamped on the transmission tag. To identify the transmission model designation and serial number, locate the tag on the transmission and then locate the numbers as shown.

DO NOT REMOVE OR DESTROY THE TRANSMISSION IDENTIFICATION TAG.

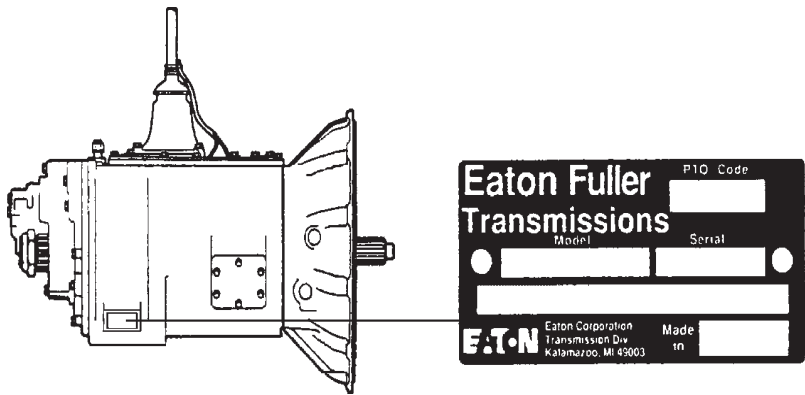

The blank spaces provided below are for recording transmission identification data and part numbers of maintenance items. Have these reference numbers handy when ordering replacement parts or requesting service information.

Transmission Model _____

Transmission Serial Number _____

Every effort has been made to ensure the accuracy of all information in this brochure. However, Eaton makes no expressed or implied warranty or representation based on the enclosed information. Any errors or omissions may be reported to Technical Service, Eaton, P.O. Box 4013, Kalamazoo, Michigan 49003-4013.

Warnings

Warnings and Precautions



Read the entire driver instructions before operating this transmission.

Set the parking brakes before starting a vehicle, always be seated in the driver's seat, move the shift level to neutral, and depress the master clutch.

If engine cranks in any gear other than neutral or without the master clutch depressed, service your vehicle neutral safety start circuit immediately.

Before working on a vehicle or when leaving the cab with the engine running, place the transmission in neutral and set the parking brakes.

Do not release the parking brake or attempt to select a gear until the air pressure is at the correct level.

When parking the vehicle or leaving the cab, always place the shift lever in neutral and set the parking brakes.

If your vehicle is equipped with a remote throttle, before operation, the transmission must be in neutral.

TOWING: To avoid damage to the transmission during towing, disconnect the driveline.

Table of Contents

Model Designations

Nomenclature.....	1
-------------------	---

Shift Lever Positions

RTLO	2
------------	---

General Information / Features

General Information	3
---------------------------	---

Operation

Driving Tips	6
--------------------	---

Lubrication

Proper Lubrication.....	12
-------------------------	----

Preventive Maintenance

Preventive Maintenance	16
------------------------------	----

Appendix

13-Speed Top 2 - Basic Operation and Overview	18
---	----

Model Designations

Nomenclature

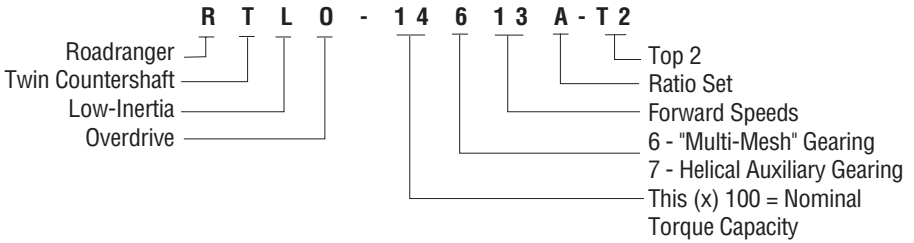

IMPORTANT: All Eaton® Fuller® Transmissions are identified by the model and serial number. This information is stamped on the transmission identification tag and affixed to the case.

DO NOT REMOVE OR DESTROY THE TRANSMISSION IDENTIFICATION TAG.

Shift Lever Positions

Shift Patterns

RTLO 1X713A Series
RTLO XX913A Series
RTLO 1X713A-T2 Series
RTLO XX913A-T2 Series

Eaton® Fuller®
Transmissions

13 SPEED (RTO, RTLO, RTOX)

SPLITTER SELECTOR
MAY BE SHIFTED
IN 5-6-7-8 ONLY

**DO NOT RANGE SHIFT
WITH SPLITTER
SELECTOR IN H**

PRE-SELECT ALL RANGE SHIFTS
(MOVE RANGE SELECTOR **BEFORE** MOVING SHIFT LEVER)

UPSHIFTING
START WITH RANGE SELECTOR DOWN
SHIFT LO-1-2-3-4 RAISE RANGE SELECTOR
SHIFT 5-6-7-8

DOWNSHIFTING
SHIFT 8-7-6-5 MOVE RANGE SELECTOR DOWN
SHIFT 4-3-2-1-LO

DO NOT CHANGE RANGE WHILE MOVING IN REVERSE

WARNING PUT TRANSMISSION IN NEUTRAL
BEFORE STARTING ENGINE

EATON

4300764

General Information

General Information

Models in this series provide thirteen forward speeds and two reverse, consisting of a five-speed front section and a 3-speed auxiliary section. The auxiliary section contains LO and HI range ratios, plus the L and H splitter gear ratios.

The LO position in the front section is used only as a starting gear. The other four ratios are used once in LO range and once again in HI range. Each of the four ratios, when used in HI range, can be split with the splitter control button.

After shifting out of the LO position, use the Roadranger repeat “H” shift pattern. LO range and HI range are selected with the range lever. It is used once during the upshift and once during the downshift sequence.

Always preselect the range shift. After preselection, the transmission will automatically make the synchronizer range shift as the shift lever passes through neutral.

When in HI range, the gear ratios can be split by using the Splitter Control Button. The “L”/Rearward position gives the 5th, 6th, 7th, and 8th speed ratios; the “H”/Forward position splits each of the HI range speed ratios. Therefore, eight progressive HI range ratios can be obtained.

Transmission Features

Range Shift

The range lever selects LO or HI range. It is used once during an upshift sequence and once during a downshift sequence.

Preselect

Note: Always preselect all range and splitter shifts when upshifting or downshifting. Preselection requires that the range lever and/or splitter button are moved to the needed position before starting the shift.

Preselected range shifts are completed automatically as the lever is moved through neutral and into the next gear. Preselecting all range shifts prevents damage to the transmission and provides for smoother shifts.

Preselected splitter shifts allow smooth and faster shifts. However, do not delay, start and complete the shift immediately after preselecting the splitter to avoid unnecessary wear on internal transmission parts.

Splitter Shift

The splitter control button selects LO split “L” or HI split “H”. It is used in each HI range speed ratio.

Features

Optional Equipment

For easier and faster gear engagement while the vehicle is standing still, some Eaton Fuller transmissions may be equipped with either a Countershaft Brake or a Clutch Brake.

Countershaft Brake

(Used with push-type clutches) - The control button is mounted on the shift lever just below the shift knob. To operate, disengage the clutch, press down the control button, and shift into LO or reverse. This is an air-operated mechanical brake which slows down the transmission gearing by forcing a piston against the countershaft PTO gear.



CAUTION: Never use the Countershaft brake when upshifting or downshifting. Use **only** for initial gear engagement when the vehicle is standing still.

Clutch Brake

(Used with pull-type clutches) -The clutch brake is applied by fully depressing the clutch pedal to the floor board. When applied, the brake slows down and can stop the transmission front box gearing. It is a disc-type brake incorporated into the clutch and transmission drive gear assemblies.



CAUTION: Never use the Clutch Brake when upshifting or downshifting. Use **only** for initial gear engagement when the vehicle is standing still.

Driving Tips

- Always select an initial starting gear that provides sufficient reduction for the load and terrain.
- Always use normal double-clutching procedures when making lever shifts.
- Never slam or jerk the shift lever to complete gear engagements.
- Never coast with the shift lever in neutral position.
- Never move the shift lever to the LO gear position while operating in HI range.
- Never move the range lever with the shift lever in neutral while the vehicle is moving.
- Never make a range shift or splitter shift while moving in reverse.
- Never downshift at too high of a road speed.
- In most cases, depending on the engine and axle ratios, you can save valuable fuel by operating the vehicle at less than governed RPM while cruising in 8th.

Operation

Double-Clutching Procedure

When ready to make a shift:

1. Depress the pedal to disengage the clutch.
2. Move the gear shift lever to neutral.
3. Release the pedal to engage the clutch.*
 - a. UPSHIFTS - Decelerate engine until engine RPM and road speed match.
 - b. DOWNSHIFTS - Accelerate engine until engine RPM and road speed match.
4. Quickly depress pedal to disengage clutch and move gear shift lever to next gear speed position.
5. Release pedal to engage clutch.

*By engaging the clutch with the gear shift lever in the neutral position, the operator is able to control the RPM of the mainshaft gears since they are regulated by engine RPM. This procedure enables the operator to match the RPM of the mainshaft gears with those of the mainshaft driven by the vehicle's rear wheels.

Initial Start-up



WARNING: Before starting a vehicle always be seated in the driver's seat, move the shift lever to neutral, and set the parking brakes.



CAUTION: Before moving a vehicle, make sure you understand your shift pattern configuration. Some where in the vehicles cab should be a shift label.

1. Make sure the shift lever is in neutral and the parking brakes are set.
2. Turn on the key switch, start the engine.
3. Allow the vehicle air pressure to build to the correct level. Refer to your "Operator and Service Manual" supplied with the truck.
4. Apply the service brakes on the vehicle.
5. Release the parking brakes on the vehicle.
6. Make sure the range lever is down in the LO range position and the splitter control button is rearward.



Range Lever **MUST** be
Down for LO Range.



And Splitter Control
Button Rearward

7. Depress the clutch pedal to the floor.
8. Move the shift lever to desired initial gear.
9. Slowly release the clutch pedal and apply accelerator.

Operation

Shifting

In the following instructions, it is assumed that the driver is familiar with operating heavy duty-trucks and tractors, and can coordinate the movement of the shift lever and clutch pedal to make smooth gear engagements while upshifting and downshifting. Always double-clutch when making lever shifts.



CAUTION: Never move the range lever or the splitter control button with the shift lever in neutral while the vehicle is moving.

Upshifting

1. Move the shift lever, double-clutching, to the next desired gear position in LO range.

Range Shift - LO to HI Range “L” (4th to 5th L)...

2. When in last gear position for LO range and ready for the next upshift, pull up the range lever and move the shift lever, double-clutching, to the next higher speed position according to your shift pattern. As the shift lever passes through neutral the transmission will automatically shift from LO to HI range.



CAUTION: Never move the shift lever to the LO gear position after HI range preselection, or at any time the transmission is in HI range.

Splitter Shift - HI range “L” to HI range “H” (5th L to 5th H)...

3. Move the splitter control button into the forward position.
4. Then, **immediately** release the accelerator, depress the clutch pedal once to break torque, release the pedal to re-engage the clutch, allow the engine to decelerate until synchronous is reached between engine speed and the next gear ratio. Continue driving or upshifting.

Combination Lever shift and Splitter Shift - HI Range “H” to HI Range “L” (5th H to 6th L)...

5. Move the splitter control button into the rearward position.
6. Move the shift lever, double-clutching, to the 6th L speed gear position. If the splitter control button is not moved, the transmission will be in 6th H once the final clutch engagement is made.



CAUTION: Never move the splitter control button or the range lever with the shift lever in neutral while the vehicle is moving.

7. Continue upshifting through the shift pattern. Double-clutching during lever shifts, single-clutch during split shifts while the shift lever is in the same position.

Downshifting

Splitter Shift - HI Range “H” to HI Range “L” (8th H to 8th L)...

1. Move the splitter control button into the rearward position.
2. Then, **immediately**, release the accelerator, depress the clutch pedal once to break torque, release the pedal to re-engage the clutch, increase engine speed until synchronous is reached. The shift then completes. Continue driving or downshifting.

Combination Lever shift and Splitter shift - HI Range “L” to HI Range “H” (7th L to 6th H)...

3. Move the splitter control button into the forward position.
4. Then, **immediately** move the shift lever, double-clutching, to the next lower gear position. If the splitter control button is not moved, the transmission will be in 7th “L” once the final clutch engagement is made.
5. Continue downshifting through HI range. Double-clutching during lever shifts, single-clutch during split shifts while the shift lever is in the same position.

Operation

Range shift from HI Range “L” to LO Range (5th L to 4th)...

6. While in HI range “L” and ready for the next downshift, preselect LO range, push the range lever down.



CAUTION: When downshifting from HI range to LO range, the splitter control button must be in the rearward position and the shift to the “L” position completed before making the range shift. The shift to LO range cannot be made with the splitter control button in the forward position.

7. Continue moving the shift lever, double-clutching, to the next desired gear position in LO range. As the shift lever passes through neutral, the transmission automatically shifts from HI range to LO range.
8. Continue downshifting, double-clutching, to the next desired gear position in LO range.

Proper Lubrication

Proper lubrication procedures are key to a good all-around maintenance program. If the lubricant is not doing its job or if the lubricant level is ignored, all the maintenance procedures in the world are not going to keep the transmission running or assure long transmission life.

Eaton® Fuller® Transmissions are designed so the internal parts operate in an oil bath circulated by the motion of the gears and shafts.

Thus, all parts are amply lubricated if these procedures are closely followed:

1. Maintain lubricant level and inspect regularly.
2. Follow maintenance interval chart.
3. Use the correct grade and type of lubricant.
4. Buy lubricant from an approved dealer.

Mixing of Oil Types



CAUTION: Never mix engine oils & gear oils in the same transmission.

Note: Additives and friction modifiers must not be introduced.

Engine oils and gear oils may not be compatible; mixing can cause breakdown of the lubricant and affect component performance. When switching between types of lubricants, all areas of each affected component must be thoroughly flushed.

Note: For a list of Eaton approved synthetic lubricants, see TCMT-0020 or call 1-800-826-HELP (4357).

Lubrication

Proper Transmission Lubrication Level

Make sure the transmission lubricant is level with the bottom of the fill opening. Being able to reach the lubricant with your finger does not mean the lubricant is at the proper level. (On heavy duty transmissions, one inch of lubricant level equals about one gallon of lubricant.)

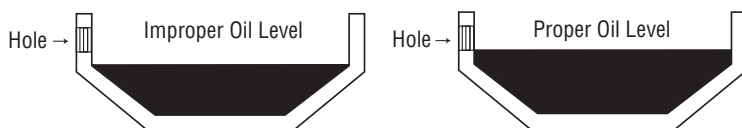

If the transmission operating angle is more than 12 degrees, improper lubrication can occur. The operating angle is the transmission mounting angle in the chassis plus the grade (expressed in degrees).

Any time the transmission operating angle of 12 degrees is exceeded for an extended period of time, the transmission must be equipped with an oil pump or cooler kit to insure proper lubrication.

Lube Change Intervals

Lubricant changes should be based on a combination of the intervals shown in TCMT-0021, the Roadranger Products Lubrication Manual, and user judgment based on the application and operating environment. Extending drain intervals beyond those shown in the tables is not recommended and will put warranties at risk.

Note: The first lube change for a Line-Haul vehicle may be extended to 500,000 miles (800,000 km) when a new transmission has been factory filled with a lube that is Eaton approved for 500,000 miles (800,000 km) (E-500, PS-164).

Note: Vocational service applications are those which require components to be consistently operated at heavy loads, in contaminated environments or on steep grades. For these applications, the Vocational Service section should be used.

Operating Temperatures

Transmissions must not be operated at temperatures above 250°F [120°C]. Operation at temperatures above 250°F [120°C] causes loaded gear tooth temperatures to exceed 350°F [177°C] which will ultimately destroy the heat treatment of the gears. If the elevated temperature is associated with an unusual operating condition that will recur, a cooler should be added, or the capacity of the existing cooling system increased.

The following conditions in any combination can cause operating temperatures over 250°F [121°C].

- Operating consistently at slower speeds
- High ambient temperatures
- Restricted air flow around transmission
- High horsepower
- Use of engine retarder

Transmission coolers must be used to reduce operating temperatures when the above conditions are encountered.

On vehicles equipped with two transmission oil temperatures gauges, one gauge (required) senses torque converter oil, while the other gauge (optional) reads oil temperature from the transmission sump. The sump temperature represents oil that has circulated through the cooler. This temperature is normally below 225°F; however, intermittent sump temperatures to 250°F do not harm the transmission.

Lubrication

Lubrication Change

Draining Oil

Drain transmission while oil is warm. To drain oil, remove the two (2) drain plugs at the case bottom and oil pan. Clean the drain plugs and flush the cooler circuit before re-installing.

Refilling

The operational level should always be within the appropriate temperature bands on the dipstick. The exact amount of oil depends on the transmission inclination and model. Insufficient oil damages the pump and other components, and can affect the function and reduce the life of the transmission.

DO NOT OVERFILL! This causes overheating and loss of fuel economy.

When adding oil, types and brands of oil should not be mixed because of possible incompatibility.

Use clean oil and clean containers when filling transmission. Containers that have been used for anti-freeze or water should not be used for transmission oil.

1. Remove the dipstick and slowly add of the prescribed oil through the fill tube.
2. Place the transmission in neutral position and apply the parking brakes. Start the engine and let it idle for five (5) minutes, (this allows oil to fill the converter, main case, and cooling system). Add oil as needed to obtain a level at the proper temperature range. Total oil quantity varies depending on the cooling system.
3. Increase the engine idle slowly to 1500 RPM for five (5) minutes. Now recheck the oil level at normal idle speed in neutral, again adding oil to obtain a level at the proper temperature range.
4. Replace the dipstick and tighten securely.

For additional lubrication information, see TCMT0021.

Preventive Maintenance

The following maintenance items are necessary to prevent costly transmission failures which may not be covered under warranty.

Transmission Oil

- Check transmission daily for oil leaks. Repair promptly to prevent oil loss and subsequent transmission failure
- Check transmission oil level at every engine oil change interval. Add transmission oil as necessary.
- Drain and replace transmission oil as recommended in TCMT-0021.

Air System

- Drain moisture from vehicle air system daily.
- Listen for air leaks daily, repair promptly.
- If the vehicle is equipped with an air dryer, confirm that the air dryer system is working properly. Repair as necessary.
- Service the vehicle air compressor as required to prevent oil from entering the vehicle air system.

Master Clutch System

- Lubricate clutch release pedal shaft bushings at every chassis lubrication interval. There should be one grease fitting on each side of the transmission clutch housing.
- Have the clutch checked and adjusted if any of the following occurs:
Clutch does not disengage completely
Clutch brake does not function
Clutch pedal free-play is less than 1/2"
- When replacing the clutch, use a high quality spring damped replacement unit.

Preventive Maintenance

Drivetrain

- Inspect the driveshaft for loose or worn U-joints weekly. Repair promptly to prevent excessive driveline vibration
- Have the driveline checked by a repair facility if unusual noise or vibration is detected.

Overall Inspection

- Inspect the transmission at the chassis lubrication interval for loose or missing capscrews and fasteners. Pay particular attention to the capscrews that attach the transmission to the engine.

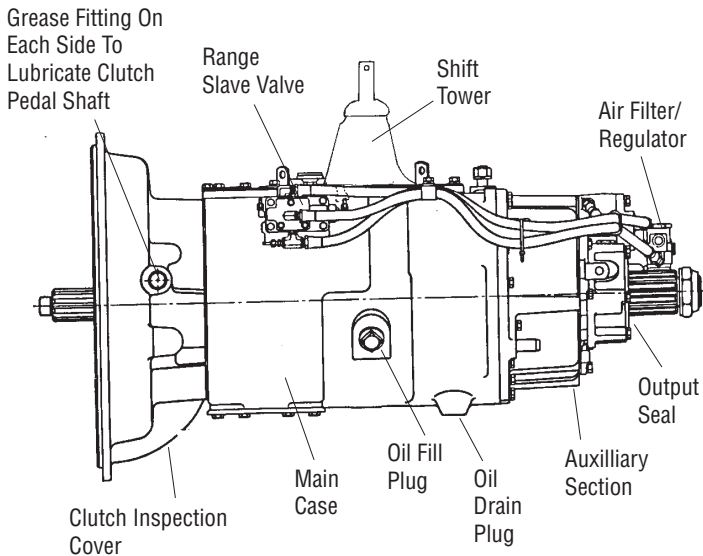

13-Speed Top 2 - Basic Operation and Overview

The Super 13 Top 2 transmission operates like a normal Super 13 in positions LO through 7th H. The transmission shifts automatically in the "AUTO" position based on engine speed and load.

When the transmission is in the Top 2 Mode, the system will:

- Shift the transmission between top 2 gears automatically.
- Increase or decrease engine speed during a Top 2 shift.
- Momentarily interrupt cruise control or engine brake during shift.

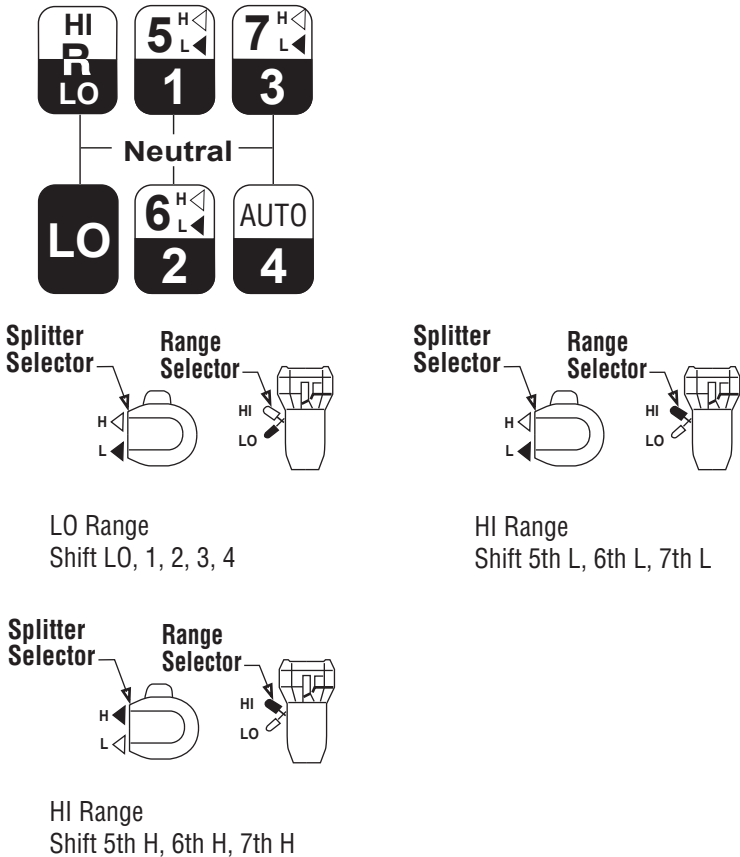

Appendix

Upshift Procedure

1. Upshift the transmission through the shift pattern to 7th H position. Double-clutching during lever shifts and breaking torque during button shifts.
2. When the engine has reached the shift point use the normal double-clutching procedure and move the shift lever into “AUTO” position.

Note: The position of the splitter selector does not matter when moving the lever into the AUTO position. It is recommended to leave the splitter selector in the forward position so it is ready when you want to make a downshift into 7th H position.

3. When the engine has reached the shift point the transmission will automatically shift into top gear.

Downshift Procedure

1. To downshift from top gear: Once the engine has reached the shift point the transmission will automatically downshift.
2. To downshift from “AUTO” position to 7th H:
 - a. While in AUTO position, make sure the splitter selector is in the forward position.
 - b. Once the engine has reached the shift point move the lever to the next lower lever position while double-clutching.
3. Continue downshifting through the shift pattern, double-clutching during lever shifts and breaking torque during button shifts.

Driving Tips

To activate Top 2 mode, the transmission must be shifted from 7th H to AUTO once the engine has reached the normal shift point. If the operator moves the shift lever into the AUTO lever position below the engine's normal shift point, the transmissions will be in normal Super 13 mode. Once the engine reaches the normal shift point, Top 2 mode will become active.

Throttle position determines the upshift point. Less throttle will lower the shift point. Zero throttle (down hill push) will raise the upshift point. To reset the shift points the engine must drop below its normal shift point.

With the engine brake active, the up and down shift points will be raised.

A feature of Top 2 is ANTI HUNT mode. This is built in to avoid constant up and downshifts. When the shift lever is in the AUTO position and the transmissions just completed an upshift, the downshift point will be lower than normal. If the transmission has just completed a downshift, the upshift point will now be higher than normal.

Appendix

Definitions

Auto Position	When the shift lever is in the position labeled “AUTO”. This position is where the Top 2 gears are located.
Break Torque	Releasing engine power or load from transmission and drivetrain.
Double-Clutch	The shifting technique used when moving the shift lever to the next lever position.
Splitter Selector	The button on the side of the shift knob used to change gears.
Synchronous	The point at which the input gearing speed (engine) matches output gearing speed (road speed) and a shift can occur without grinding.
Top 2 Mode	The state where the transmission automatically shifts between the top two gears.

System Problem

If the system malfunctions, the transmissions will typically default to Super 13 mode. For some malfunctions, the system will detect a failure, that the operator must allow the Top 2 to time out - this will take 9 seconds. During the 9 seconds the Top 2 will try to complete the shift. Once the Top 2 has timed out, the operator must place the transmission in neutral to obtain manual Super 13 mode. The Top 2 function will be inactive until vehicle is stopped and the key is turned off.

In some situations, the system can be reset at a stop by leaving the key off for 10 seconds and then restarting the engine. If this does not clear the problem, verify air pressure and check the electrical connections to the Top 2. To help assure operation of the Super 13 Top 2, advise your maintenance personnel of any oil leaks, above normal operating temperatures, unusual noises, fault codes, or if the transmission is not operating right.

These instructions assume the driver is currently familiar with the operation of a normal Super 13 transmission.

Copyright Eaton, 2014.

Eaton hereby grant their customers, vendors, or distributors permission to freely copy, reproduce and/or distribute this document in printed format. It may be copied only in its entirety without any changes or modifications. THIS INFORMATION IS NOT INTENDED FOR SALE OR RESALE, AND THIS NOTICE MUST REMAIN ON ALL COPIES.

Note: Features and specifications listed in this document are subject to change without notice and represent the maximum capabilities of the software and products with all options installed. Although every attempt has been made to ensure the accuracy of information contained within, Eaton makes no representation about the completeness, correctness or accuracy and assumes no responsibility for any errors or omissions. Features and functionality may vary depending on selected options.

For spec'ing or service assistance, call 1-800-826-HELP (4357) or visit www.eaton.com/roadranger. In Mexico, call 001-800-826-4357.

Roadranger: Eaton and trusted partners providing the best products and services in the industry, ensuring more time on the road.

Eaton

Vehicle Group
P.O. Box 4013
Kalamazoo, MI 49003 USA
800-826-HELP (4357)
www.eaton.com/roadranger

Printed in USA



BACKED BY
Roadranger
SUPPORT