

Driver Instructions

Video Instruction Available

Instructional videos are available for download at no charge at roadranger.com

Videos are also available for purchase. To order, call 1-888-386-4636. Ask for item # RRSD0002

Fuller Mid-Range Transmissions TRDR0150 September 2007

FS-4005A	FS-5406N
FS-4005B	FS-6205A
FS-4005C	FS-6205B
FS-4205A	FS-6206A
FS-4205B	FS-6305A
FS-4205C	FS-6305B
FS-5005A	FS-6306A
FS-5005B	FS-6406A
FS-5005C	FS-6406N
FS-5106A	FS-7206A
FS-5205A	FS-8206A
FS-5205B	FSB-5406B
FS-5205C	FSO-4305
FS-5306A	FSO-6406A
FS-5406A	FSO-8406A



Powering Business Worldwide

BACKED BY

Roadranger

SUPPORT

Warnings

Warnings and Cautions



Read the entire driver instructions before operating this transmission.

Set the parking brakes before starting a vehicle, always be seated in the driver's seat, move the shift level to neutral, and depress the master clutch.

If engine cranks in any gear other than neutral or without the master clutch depressed, service your vehicle neutral safety start circuit immediately.

Before working on a vehicle or when leaving the cab with the engine running, place the transmission in neutral and set the parking brakes.

Do not release the parking brake or attempt to select a gear until the air pressure is at the correct level.

When parking the vehicle or leaving the cab, always place the shift lever in neutral and set the parking brakes.

TOWING: To avoid damage to the transmission during towing, disconnect the driveline.

Table of Contents

Introduction

Warnings and Precautions	i
Tag Information	1
Nomenclature.....	2
Shift Positions.....	3
General Information	4

Operation

Driving Operation	5
-------------------------	---

Lubrication

Proper Lubrication	8
--------------------------	---

Preventive Maintenance

Maintenance Checks	12
--------------------------	----

Introduction

Tag Information

Transmission model designation and other transmission identification information are stamped on the transmission tag. To identify the transmission model designation and serial number, locate the tag on the transmission and then locate the numbers as shown.

IMPORTANT: DO NOT REMOVE OR DESTROY THE TRANSMISSION IDENTIFICATION TAG.

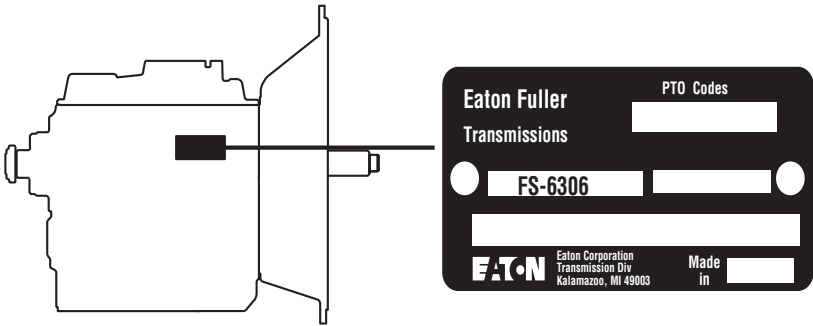

The blank spaces provided below are for recording transmission identification data and part numbers of maintenance items. Have these reference numbers handy when ordering replacement parts or requesting service information:

Transmission Model: _____

Transmission Serial Number: _____

Every effort has been made to ensure the accuracy of all information in this manual. However, Eaton Truck Components Operation makes no expressed or implied warranty or representation based on the enclosed information. Any errors or omissions may be reported to Marketing Services, Eaton Truck Components Operation P.O. Box 4013, Kalamazoo, Michigan 49003-4013.

Nomenclature

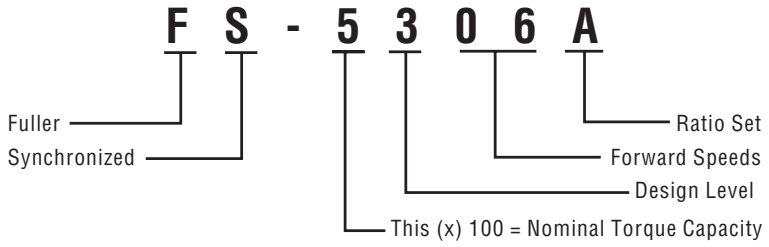

Introduction

Shift Positions

6-Speed

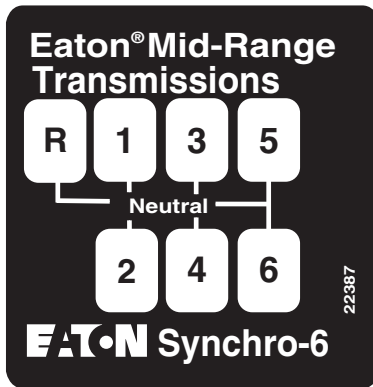

General Information

Models in this series provide six forward speeds and one reverse, and are shifted as you would shift any synchronized manual transmission. Follow the simple 6-speed shift pattern.

Shift Pattern Diagram

A shift pattern diagram should be in your vehicle. If it has been lost, a replacement may be obtained by writing to:

Eaton Corporation
Truck Components
Global Marketing Services
P.O. Box 4013
Kalamazoo, Michigan 49003
www.roadranger.com

Please specify shifting controls used and transmission model number when making request.

Operation

Driving Operation

Driving Tips

- Always use the clutch when making upshifts or downshifts. Premature synchronizer failure can result from not using the clutch.
- Always select an initial starting gear that provides sufficient reduction for the load and terrain.
- Never slam or jerk the shift lever to complete gear engagements.
- Never coast with the shift lever in the neutral position.
- Never downshift at too high of a road speed.

Double-Clutching Procedure

When ready to make a shift:

1. Depress the pedal to disengage the clutch.
2. Move the gear shift lever to neutral.
3. Release the pedal to engage the clutch.*
 - a. UPSHIFTS - Decelerate engine until engine RPM and road speed match.
 - b. DOWNSHIFTS - Accelerate engine until engine RPM and road speed match.
4. Quickly depress pedal to disengage clutch and move gear shift lever to next gear speed position.
5. Release pedal to engage clutch.

*By engaging the clutch with the gear shift lever in the neutral position, the operator is able to control the RPM of the mainshaft gears since they are regulated by engine RPM. This procedure enables the operator to match the RPM of the mainshaft gears with those of the mainshaft driven by the vehicle's rear wheels.

Initial Start-Up



WARNING: Before starting a vehicle, always be seated in the driver's seat, move the shift lever to neutral, and depress the master clutch.



CAUTION: Before moving a vehicle, make sure you understand your shift pattern configuration.

1. Make sure the shift lever is in neutral and the parking brakes are set.
2. Turn on the key switch, start the engine.
3. Apply the service brakes.
4. Depress the clutch pedal to the floor.
5. Move the shift lever to desired initial gear.
6. Release the parking brakes on the vehicle.
7. Slowly release the clutch pedal and apply accelerator.

Operation

Upshift

In the following instructions, it is assumed that the driver is familiar with operating heavy-duty trucks and tractors, and can coordinate the shift lever movement and clutch pedal to make smooth gear engagements while upshifting or downshifting.

1. Depress the clutch pedal, move the shift lever to next desired speed.
2. Release the clutch pedal.
3. Accelerate.
4. Continue upshifting.

Downshift

In the following instructions, it is assumed that the driver is familiar with operating heavy-duty trucks and tractors, and can coordinate the shift lever movement and clutch pedal to make smooth gear engagements while upshifting or downshifting.

Note: Although the transmission's first gear is synchronized it is advised that a downshift into first gear be completed at a very slow vehicle speed to prevent engine overspeed.

1. Always use the clutch when downshifting from gear to gear to prevent premature synchronizer failure.
2. Depress the clutch pedal, move the shift lever to next desired speed.
3. Release the clutch pedal.
4. Slow vehicle.
5. Continue downshifting.

Proper Lubrication

Proper lubrication procedures are key to a good all-around maintenance program. If the lubricant is not doing its job or if the lubricant level is ignored, all the maintenance procedures in the world are not going to keep the transmission running or assure long transmission life.

Eaton® Fuller® Transmissions are designed so the internal parts operate in an oil bath circulated by the motion of the gears and shafts.

Thus, all parts are amply lubricated if these procedures are closely followed:

1. Maintain lubricant level and inspect regularly.
2. Follow maintenance interval chart.
3. Use the correct grade and type of lubricant.
4. Buy lubricant from an approved dealer.

Mixing of Oil Types



CAUTION: Never mix engine oils & gear oils in the same transmission.

Note: Additives and friction modifiers must not be introduced.

Engine oils and gear oils may not be compatible; mixing can cause breakdown of the lubricant and affect component performance. When switching between types of lubricants, all areas of each affected component must be thoroughly flushed.

Note: For a list of Eaton approved synthetic lubricants, see TCMT-0020 or call 1-800-826-HELP (4357).

Lubrication

Proper Transmission Lubrication Level

Make sure the transmission lubricant is level with the bottom of the fill opening. Being able to reach the lubricant with your finger does not mean the lubricant is at the proper level. (On heavy duty transmissions, one inch of lubricant level equals about one gallon of lubricant.)

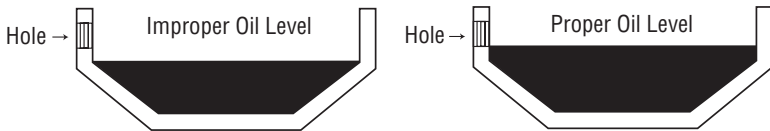

If the transmission operating angle is more than 12 degrees, improper lubrication can occur. The operating angle is the transmission mounting angle in the chassis plus the grade (expressed in degrees).

Any time the transmission operating angle of 12 degrees is exceeded for an extended period of time, the transmission must be equipped with an oil pump or cooler kit to insure proper lubrication.

Lube Change Intervals

Lubricant changes should be based on a combination of the intervals shown in TCMT-0021, the Roadranger Products Lubrication Manual, and user judgement based on the application and operating environment. Extending drain intervals beyond those shown in the tables is not recommended and will put warranties at risk.

Note: The first lube change for a Line-Haul vehicle may be extended to 500,000 miles (800,000 km) when a new transmission has been factory filled with a lube that is Eaton approved for 500,000 miles (800,000 km) (E-500, PS-164).

Note: Vocational service applications are those which require components to be consistently operated at heavy loads, in contaminated environments or on steep grades. For these applications, the Vocational Service section should be used.

Operating Temperatures

Transmissions must not be operated at temperatures above 250°F [120°C]. Operation at temperatures above 250°F [120°C] causes loaded gear tooth temperatures to exceed 350°F [177°C] which will ultimately destroy the heat treatment of the gears. If the elevated temperature is associated with an unusual operating condition that will recur, a cooler should be added, or the capacity of the existing cooling system increased.

The following conditions in any combination can cause operating temperatures over 250°F [121°C].

- Operating consistently at slower speeds
- High ambient temperatures
- Restricted air flow around transmission
- High horsepower
- Use of engine retarder
- Exhaust system too close to transmission

Transmission coolers must be used to reduce operating temperatures when the above conditions are encountered.

Transmission Oil Coolers are:

Recommended

- With engines of 350 H.P. and above

Required

- With engines of 399 H.P. and above and GCW's over 90,000 lbs,
- With engines of 399 H.P. and above and 1400 lbs. ft. or greater torque,
- With engines 450 H.P. and above.

Lubrication

Lubrication Change

Draining Oil

Drain transmission while oil is warm. To drain oil, remove the two (2) drain plugs at the case bottom and oil pan. Clean the drain plugs and flush the cooler circuit before re-installing.

Refilling

The operational level should always be within the appropriate temperature bands on the dipstick. The exact amount of oil depends on the transmission inclination and model. Insufficient oil damages the pump and other components, and can affect the function and reduce the life of the transmission.

DO NOT OVERFILL! This causes overheating and loss of fuel economy.

When adding oil, types and brands of oil should not be mixed because of possible incompatibility.

Use clean oil and clean containers when filling transmission. Containers that have been used for anti-freeze or water should not be used for transmission oil.

1. Remove the dipstick and slowly add of the prescribed oil through the fill tube.
2. Place the transmission in neutral position and apply the parking brakes. Start the engine and let it idle for five (5) minutes, (this allows oil to fill the converter, main case, and cooling system). Add oil as needed to obtain a level at the proper temperature range. Total oil quantity varies depending on the cooling system.
3. Increase the engine idle slowly to 1500 RPM for five (5) minutes. Now recheck the oil level at normal idle speed in neutral, again adding oil to obtain a level at the proper temperature range.
4. Replace the dipstick and tighten securely.

For additional lubrication information, see TCMT-0021.

Maintenance Checks

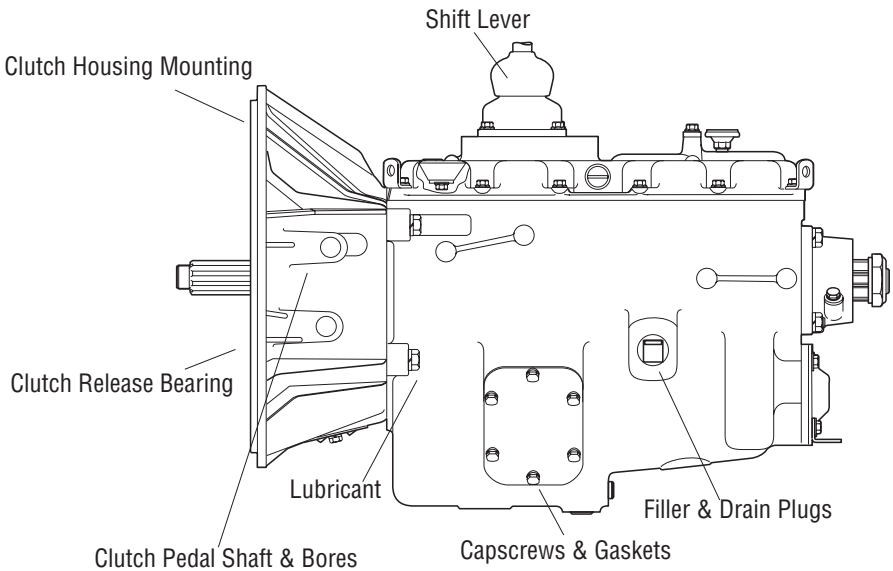

Clutch Housing Mounting

- Check all capscrews of the clutch housing flange for looseness.

Clutch Release Bearing (Not Shown)

- Remove hand hole cover and check radial and axial clearance in release bearing.
- Check relative positive of thrust surface of release bearing with thrust sleeve on push-type clutches.

Clutch Pedal Shaft and Bores

- Pry upward on shafts to check wear.
- If excessive movement is found, remove clutch release mechanism and check bushing on bores and wear on shafts.

Preventative Maintenance

Lubricant

- Change at specified service intervals.
- Use only the types and grades recommended.

Filler and Drain Plugs

- Remove filler plugs and check level of lubricant at specified intervals. Tighten filler and drain plugs securely.

Capscrews and Gaskets

- Check all capscrews, especially those on P.T.O. covers and rear bearing covers for looseness which would cause oil leakage.
- Check P.T.O. opening and rear bearing covers for oil leakage due to faulty gasket.

Shift Lever

- Check for looseness and free play in housing. If lever is loose in housing, proceed to check the Shift Lever Housing Assembly.

Shift Lever Housing Assembly

- Check tension spring and washer for set and wear.
- Check the shift lever spade pin and slot for wear.
- Check bottom end of shift lever for wear and check slot of yokes and blocks in shift bar housing for wear at contact points with shift lever.

Copyright Eaton Corporation, 2012. Eaton hereby grant their customers, vendors, or distributors permission to freely copy, reproduce and/or distribute this document in printed format. It may be copied only in its entirety without any changes or modifications. THIS INFORMATION IS NOT INTENDED FOR SALE OR RESALE, AND THIS NOTICE MUST REMAIN ON ALL COPIES.

Note: Features and specifications listed in this document are subject to change without notice and represent the maximum capabilities of the software and products with all options installed. Although every attempt has been made to ensure the accuracy of information contained within, Eaton makes no representation about the completeness, correctness or accuracy and assumes no responsibility for any errors or omissions. Features and functionality may vary depending on selected options.

For spec'ing or service assistance, call 1-800-826-HELP (4357) or visit www.eaton.com/roadranger. In Mexico, call 001-800-826-4357.

Roadranger: Eaton and trusted partners providing the best products and services in the industry, ensuring more time on the road.

Eaton Corporation

Vehicle Group
P.O. Box 4013
Kalamazoo, MI 49003 USA
800-826-HELP (4357)
www.eaton.com/roadranger

Printed in USA



BACKED BY
Roadranger
SUPPORT