

# FS(O) 10309

# ES(O) 1X409

Type	FS 10309	FSO 10309	ES 15409	ESO 17409
Max. Input Torque [Nm]	1500	1750	1600	1750
Mass [kg]	250			
Oil Quantity [l]	11.7			
Clutch Housing	SAE 1			
Overall Length [mm]	950			
Center distance [mm]	148			
GVW [t]	45 (10309) / 60 (15409)			

## General view:

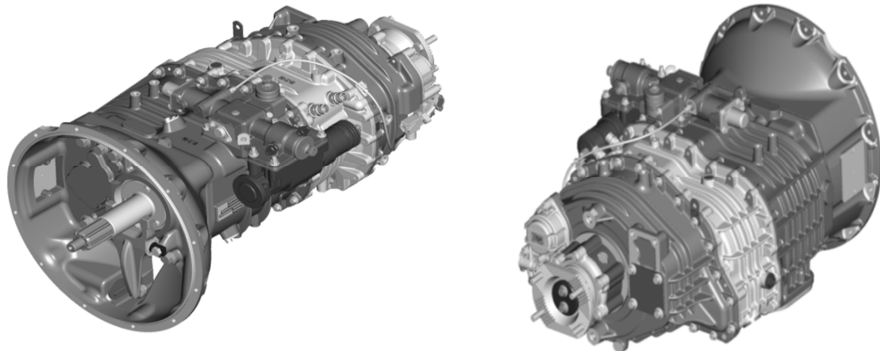
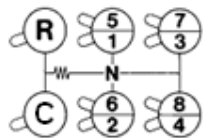
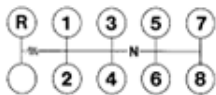

## Gear ratios:

GEAR TYPE	L	1	2	3	4	5	6	7	8	R
FS/ES	14.39	10.4	7.11	5.05	3.71	2.71	1.92	1.36	1.00	14.41
FSO/ESO	10.58	7.38	5.22	3.71	2.73	1.99	1.41	1.00	0.74	10.59

# FS(O) 10309

# ES(O) 1X409

*Basic dimensions (horizontal version):*

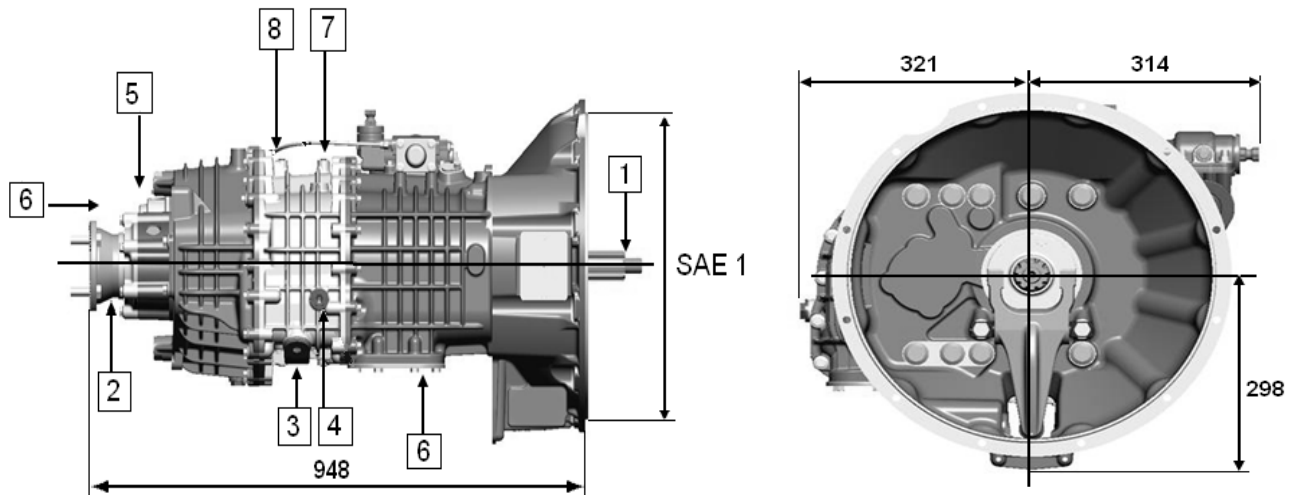

- |                            |                         |
|----------------------------|-------------------------|
| 1. Input shaft             | 5. Tachometer sensor    |
| 2. Output flange           | 6. PTO opening          |
| 3. Oil drain plug          | 7. Reverse light switch |
| 4. Oil filler & level plug | 8. Neutral light switch |

On a base of agreement with customer gearbox can be additionally fitted with:

- Vertical and horizontal installation
- Remote or Cable control options
- Fine pitch helical gears
- Single or double “H” shift pattern
- PTO: LH or Rear
- PPA, HGS
- External oil cooler provisions
- Integrated Air system
- Parking Brake provision