



*Powering Business Worldwide*

# Illustrated Parts List

---

**Y08389**

**November 2015**

# Contents

How To Use The Illustrated Parts List .....	3
CROSS GATE INTERLOCK ASSY. ....	4
FRONT BEARING COVER ASSY. ....	5
FRONT CASE ASSY.....	6
INPUT SHAFT ASSY.....	8
INTERMEDIATE CASE ASSY.....	9
LAYSHAFT ASSY. ....	11
LRC ASSEMBLY .....	13
MAINSHAFT ASSY.....	15
PLANET GEAR SPINDLE ASSY. ....	18
RANGE ASSY.....	19
RANGE CONTROL ASSY.....	21
REAR CASE ASSY. ....	23
REVERSE IDLER ASSY.....	25
SELECTOR ASSY. O/D .....	26

## How To Use The Illustrated Parts List

The information contained in this document is subject to frequent updates. Therefore, for the latest information available, please visit the interactive Electronic Parts Catalog at <http://www.eaton.com/EatonCom/TruckEurope/TruckEurope/index.htm>

### Model Designation and Nomenclature

- For information regarding Model Designation and Nomenclature, visit <http://www.eaton.com/EatonCom/TruckEurope/TruckEurope/index.htm>

### Kits and Assemblies (K/A's)

- Kits or Assemblies contain groups of individual or assembled parts specially developed for optimal replacement during repair.
- Kits and Assemblies are shown with applicable parts groupings in the parts listings.

### Identifying Kits and Assemblies

A- Part numbers beginning with the letter 'A' are pre-assembled Production Assemblies

K- Part numbers beginning with the letter 'K' are kits that are not assembled

T - Part numbers beginning with the letter 'T' are kits that are not assembled

S- Part numbers beginning with the letter 'S' are pre-assembled Service Assemblies

- Note: Some Production Assemblies do not begin with a letter prefix (Midrange only).

### Illustrations

- Illustrations show parts in assembly groups.
- Item numbers on illustrations correspond with parts listings adjacent to the illustration.(on the same or adjacent page)
- Notes are included on illustrations where additional information is needed.

### Parts Listing

Parts listings are defined by parts groupings and are broken down by service assemblies. Parts listings identify a part for servicing with the following categories

- **ITEM** - Number corresponds to number on illustration for part identification.
- **CURRENT PART** - part number of the part available for service.
- **DESCRIPTION** - part name or description.
- **REPLACED PART** - number of replaced part.
- **QTY** - Quantity required for assembly.
- **NOTES** - unique characteristics or requirements.
- **KITS / ASSYS WHERE NEEDED** - kits or assemblies that contain the part.

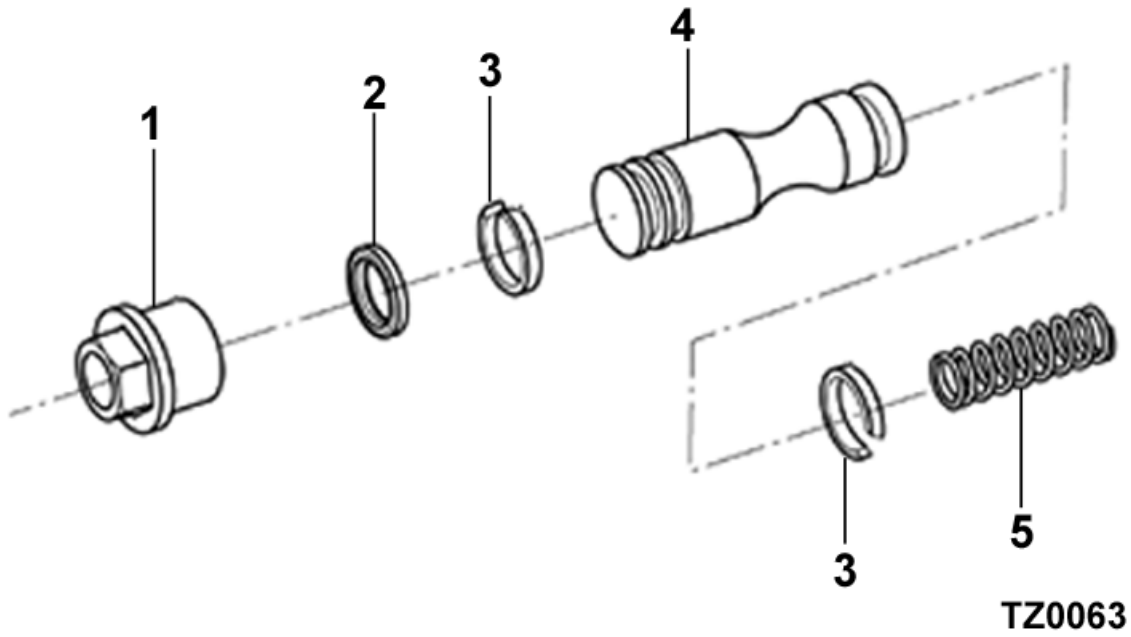

**CROSS GATE INTERLOCK ASSY.**

Item	Current Part	Description	Replaced Part	Qty.	Notes	Kits/Assys Where Needed
0	U8882180	CROSS GATE INTERLOCK ASSY		1		
1	8882133	ADAPTOR BUSH		1		
2	X8882252	PISTON SEALING		1		
3	X8882129	SLIDE RING		2		
4	8882126	PISTON		1		
5	8881333	SPRING COMPRESSION		1		

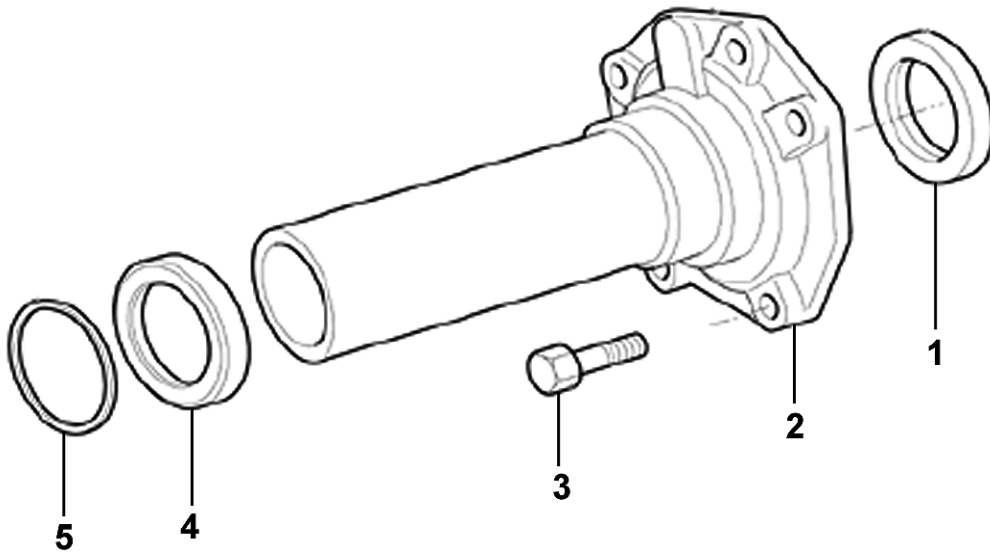

**TZ0040**

**FRONT BEARING COVER ASSY.**

Item	Current Part	Description	Replaced Part	Qty.	Notes	Kits/Assys Where Needed
0	U8877092	FRONT BEARING COVER ASSY.		1		
1	X8870760	OIL SEAL		1		
2	8877091	FRONT BEARING COVER ASSY.		1		
3	GMX-8-1089	SCREW		5	M10X25 HEX FLG HD	
4	8877523	O-RING HOUSING		1		
5	X8876391	O-RING		1	135 I.D. X 2.5 SECT	

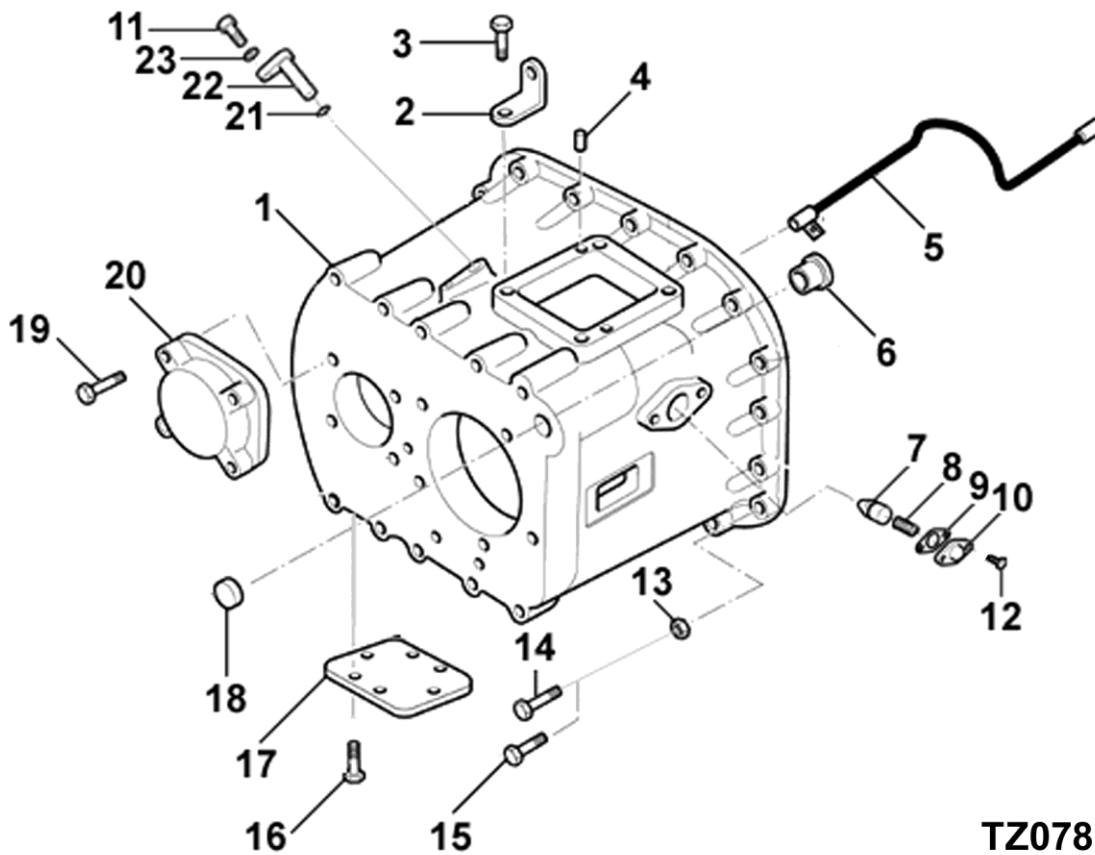

**TZ0781**

**FRONT CASE ASSY**

Item	Current Part	Description	Replaced Part	Qty.	Notes	Kits/Assys Where Needed
0	U8882246	FRONT CASE ASSY.		1		
1	8882245	FRONT CASE		1		
2	GX8879212	LIFTING EYE		1	15 MM	
3	GMX-8-1091	SCREW		4	M10X30 HEX FLG HD	
4	X8870542	DOWEL		2	8,0 DIA X 16	
5	U8880098	OIL SPRAY BAR ASSY.		1		
6	8883756	BUSH	8882415	1	FOR MAIN SELECTOR SHAFT	
7	8873654	PLUNGER-NEUTRAL		1		
8	8874897	SPRING COMPRESSION		1		
9	8870590	GASKET		1		
10	GX8870259	DETENT COVER		1		
11	GMX-8-0811	SCREW		2	M8X20	

Item	Current Part	Description	Replaced Part	Qty.	Notes	Kits/Assys Where Needed
12	GMX-8-0819	SCREW	GMX-8-0801	2	M8 X 16	
13	GMX-9-1005	NUT		14	M10X1.5	
14	GMX-8-1079	BOLT		4	M10X40	
15	GMX-8-10111	BOLT		3	M10X65 HEX FLG HD	
15	GMX-8-1080	BOLT		11	M10X58	
16	GMX-8-1088	SCREW		6	M12X25 HEX FLG HD	
17	8882124	PLATE PTO FINNED		1		
18	GX8870278	CUP PLUG		1		
19	GMX-8-1240	SCREW		4	M12X25 HEX FLG HD	
20	GX8880554	BEARING COVER LAYSHAFT		1		
21	X8877743	O-RING		2	11.1 1D X 1 .6 DIA	
22	GX8872917	ROTATION PIN O/D FORK		2		
23	GMX-3-0801	WASHER SPRING		2	M8	

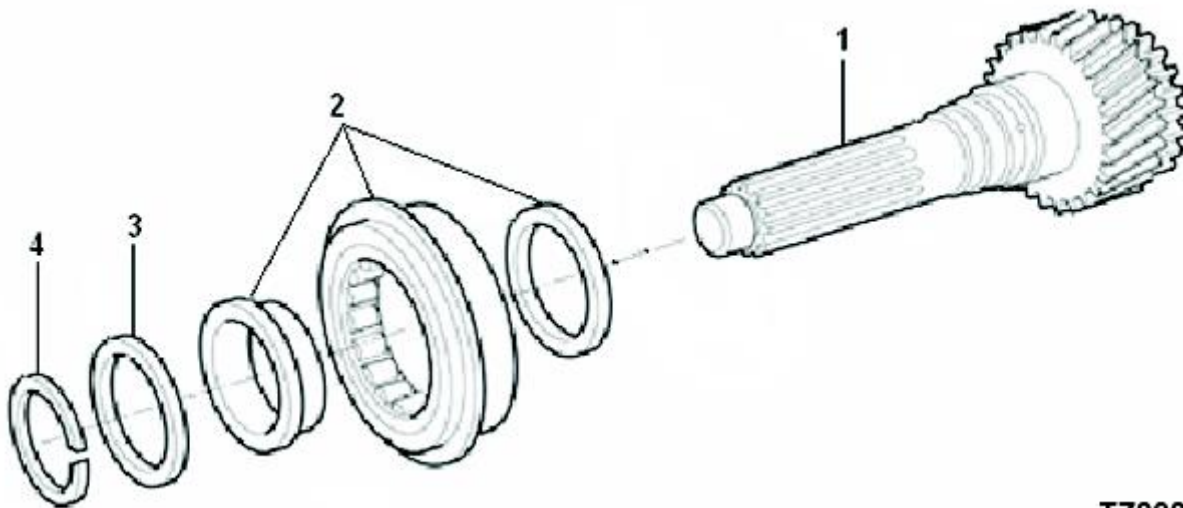

**TZ0003**

**INPUT SHAFT ASSY.**

Item	Current Part	Description	Replaced Part	Qty.	Notes	Kits/Assys Where Needed
0	U8882177	INPUT SHAFT ASSEMBLY		1		
1	8882574	INPUT SHAFT		1		
2	X8872593	INPUT SHAFT BEARING		1		
3	8877692	SPACER - GRADED 3.10		1	PACK: U8877691	
3	8877693	SPACER - GRADED 3.15		1	PACK: U8877691	
3	8877694	SPACER - GRADED 3.20		1	PACK: U8877691	
3	8877695	SPACER - GRADED 3.25		1	PACK: U8877691	
3	8877696	SPACER - GRADED 3.30		1	PACK: U8877691	
3	8877697	SPACER - GRADED 3.35		1	PACK: U8877691	
3	8877698	SPACER - GRADED 3.40		1	PACK: U8877691	
3	8877699	SPACER - GRADED 3.45		1	PACK: U8877691	
3	8877700	SPACER - GRADED 3.50		1	PACK: U8877691	
3	U8877691	SPACER - GRADED PACK		1		
4	X8877706	CIRCLIP		1		



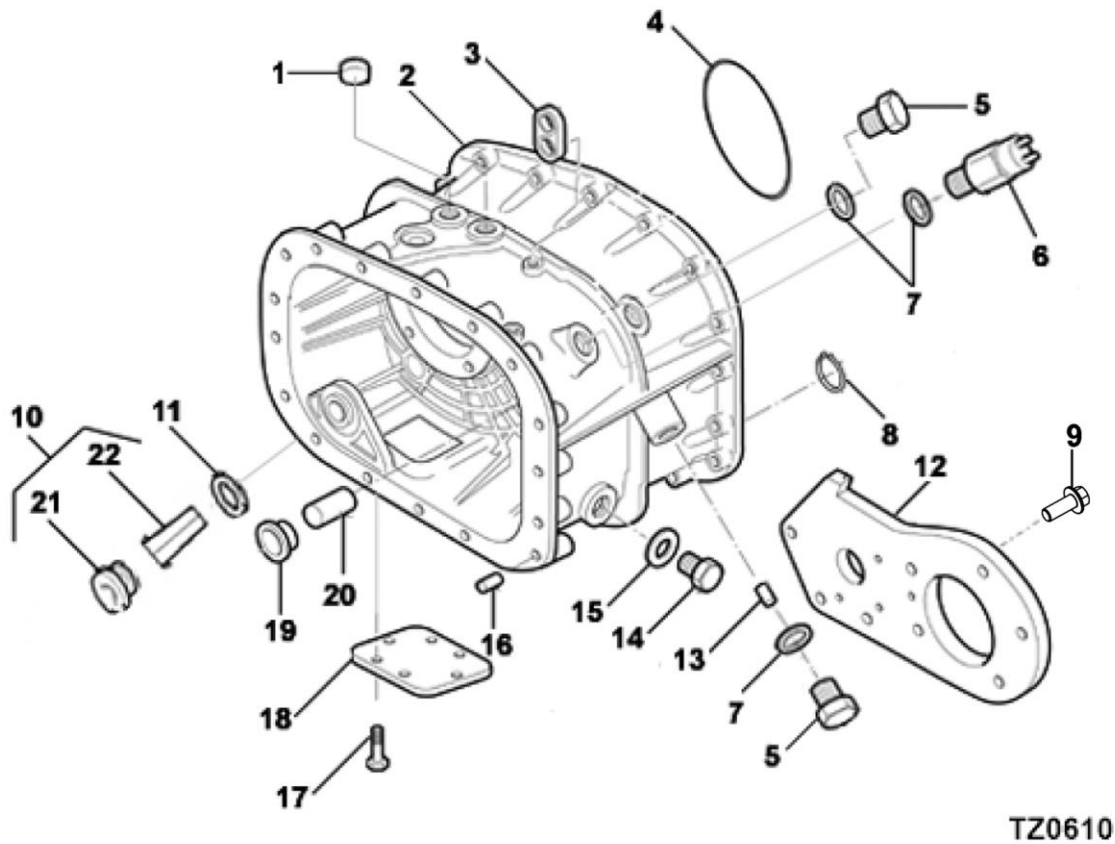

TZ0610

## INTERMEDIATE CASE ASSY.

Item	Current Part	Description	Replaced Part	Qty.	Notes	Kits/Assys Where Needed
0	T21228	SERVICE KIT OIL STRAINER/ WASHER		1	INCLUDES 8876351, GX8876352 & X8880469	
0	U8876423	INTERMEDIATE CASE ASSY		1		
1	8876744	CORE PLUG OIL RESTRICTOR		1		
2	8876418	INTERMEDIATE CASE		1		
3	GX8879211	LIFTING EYE		2		
4	X8881475	O-RING		1	(109,5X3,0)	
5	GX8871502	PLUG		2	M16	
6	GX2771532	SWITCH REVERSE / RANGE		1		
7	5568510	O-RING		3		
8	X8881424	CIRCLIP		1		
9	GMX-8-1089	SCREW		8	M10X25 HEX FLG HD	

Item	Current Part	Description	Replaced Part	Qty.	Notes	Kits/Assys Where Needed
10	U8876353	OIL STRAINER ASSY.		1		T21228
11	X8880469	WASHER-OIL STRAINER / DRAIN		1		T21228
12	U8883824	OIL PUMP ASSY.	GU8875469	1		
13	8875267	PIN INTERLOCK		1		
14	GX8874942	OIL FILLER PLUG		1		
15	X8880519	WASHER-FILL/DRAIN FL		1		
16	X8870543	DOWEL		2	16,0 DI X 30,5	
17	GMX-8-1088	SCREW		6	M12X25 HEX FLG HD	
18	8882124	PLATE PTO FINNED		1		
19	8883756	BUSH	8882415	1	FOR MAIN SELECTOR SHAFT, FOR MAIN SELECTOR SHAFT	
20	X8871377	BUSH		1		
21	GX8876352	PLUG OIL STRAINER		1		
22	8876351	STRAINER-OIL		1		

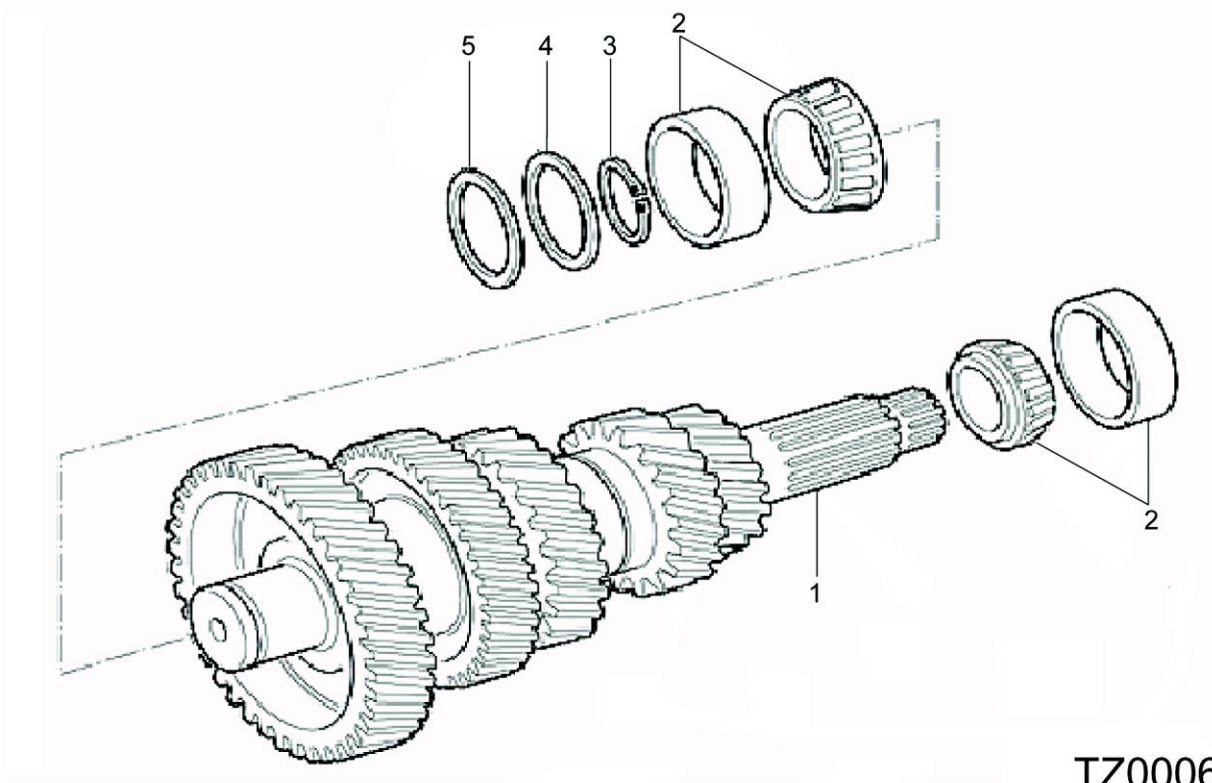

TZ0006

**LAYSHAFT ASSY.**

Item	Current Part	Description	Replaced Part	Qty.	Notes	Kits/Assys Where Needed
1	U8882178	LAYSHAFT ASSY. O/D		1		
2	X8880820	BEARING ASSEMBLY		2		
3	U8877534	CIRCLIP GRADED PACK		1		
3	X8870370	GR.C/CLIP 40 DIA. X 2.12 MM		1		
3	X8870371	GR.C/CLIP 40 DIA. X 2.07 MM		1		
3	X8870372	GR.C/CLIP 40 DIA X 2.02 MM		1		
3	X8871536	GR.C/CLIP 40 DIA. X 1.97 MM		1		
3	X8871537	GR.C/CLIP 40 DIA. X 1.92 MM		1		
3	X8871538	GR.C/CLIP 40 DIA. X 1.87 MM		1		
3	X8871539	GR.C/CLIP 40 DIA. X 1.82 MM		1		
3	X8871540	GR.C/CLIP 40 DIA. X 1.77 MM		1		

---

Item	Current Part	Description	Replaced Part	Qty.	Notes	Kits/Assys Where Needed
4	F88891	SHIM		1	S=0,051	
4	F88892	SHIM		1	S=0,127	
4	F88893	SHIM		1	S=0,254	
4	F88894	SHIM		1	S=0,508	
4	U8877535	SHIM PACK		1		
4	X8882272	SHIM		1	S=1,200	
5	8875879	SPACER		1		

---

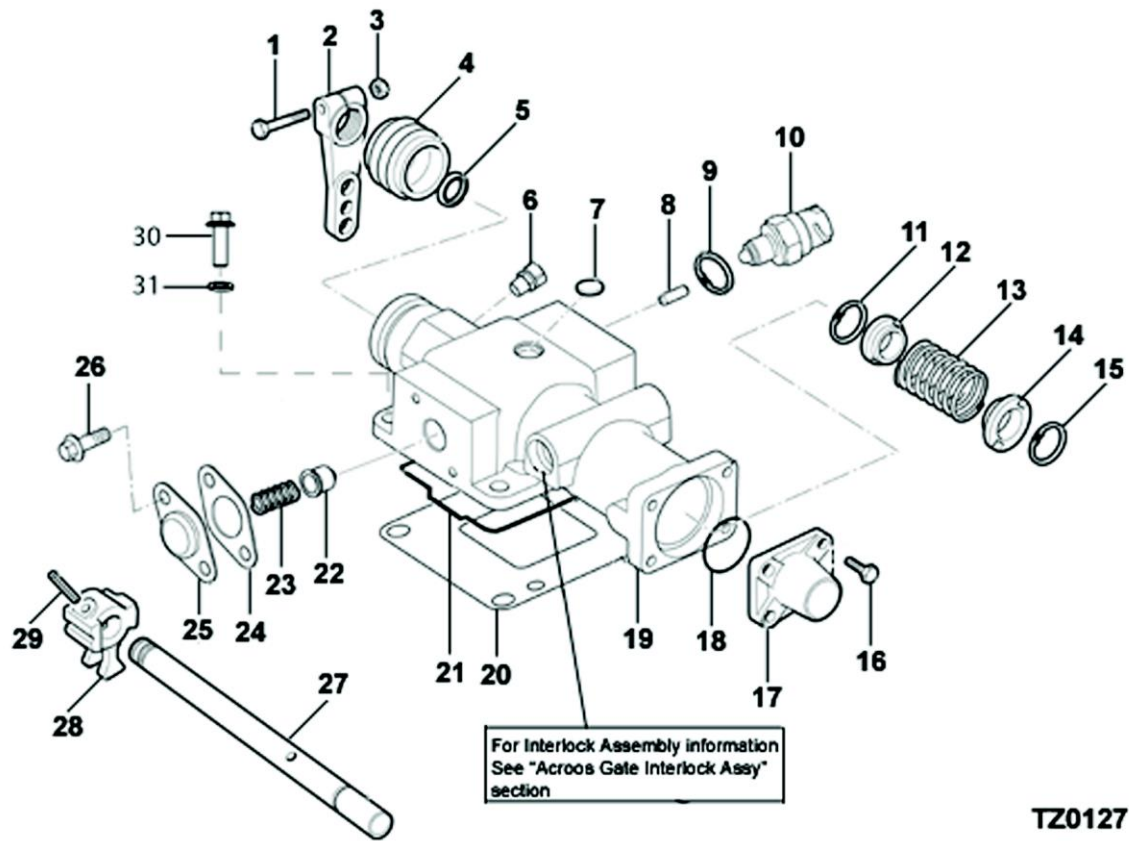

## LRC ASSEMBLY

Item	Current Part	Description	Replaced Part	Qty.	Notes	Kits/Assys Where Needed
0	U8880841	LRC ASSY. LH		1		
1	GMX-8-1007	BOLT		1	M10X50	
2	GX8876046	OUTER LEVER		1		
3	GMX-9-1005	NUT		1	M10X1.5	
4	X8875259	BOOT		1		
5	X8881481	OIL SEAL		1		
6	X8881713	STRAIGHT ADAPTOR		1	NPT TO 6 MM TUBE	
7	GX8871486	EXPANSION PLUG		1		
8	8871375	SWITCH ACTIVATOR PIN		1		
9	5568510	O-RING		1		
10	8881281	NEUTRAL SWITCH		1		
11	X8874450	CIRCLIP		1	25.DIA	
12	8876566	SPRING RETAINER-		1		

Item	Current Part	Description	Replaced Part	Qty.	Notes	Kits/Assys Where Needed
BOOSTER						
13	8873737	SPRING COMPRESSION		1		
14	8876567	SPRING RETAINER-BIAS		1		
15	X8874450	CIRCLIP		1	25.DIA	
16	GMX-8-0847	SCREW		4		
17	8880477	END CAP		1		
18	X8880639	O-RING		1		
19	U8881324	LRC SUB ASSY.		1		
20	8876045	SPACER		1		
21	8880638	SEAL		1		
22	8875415	PLUNGER - DETENT		1		
23	8874017	SPRING COMPRESSION		1		
24	8870590	GASKET		1		
25	GX8870259	DETENT COVER		1		
26	GMX-8-0848	SCREW		2		
27	GX8880771	SHIFT ROD		1		
28	8877656	LEVER INNER STRIKING		1		
29	X8871378	DOWEL		1	10,0 DIA X 44	
30	GMX-8-1091	SCREW		4	M10X30 HEX FLG HD	
31	GMX-3-1001	SPRING WASHER		4	M10	

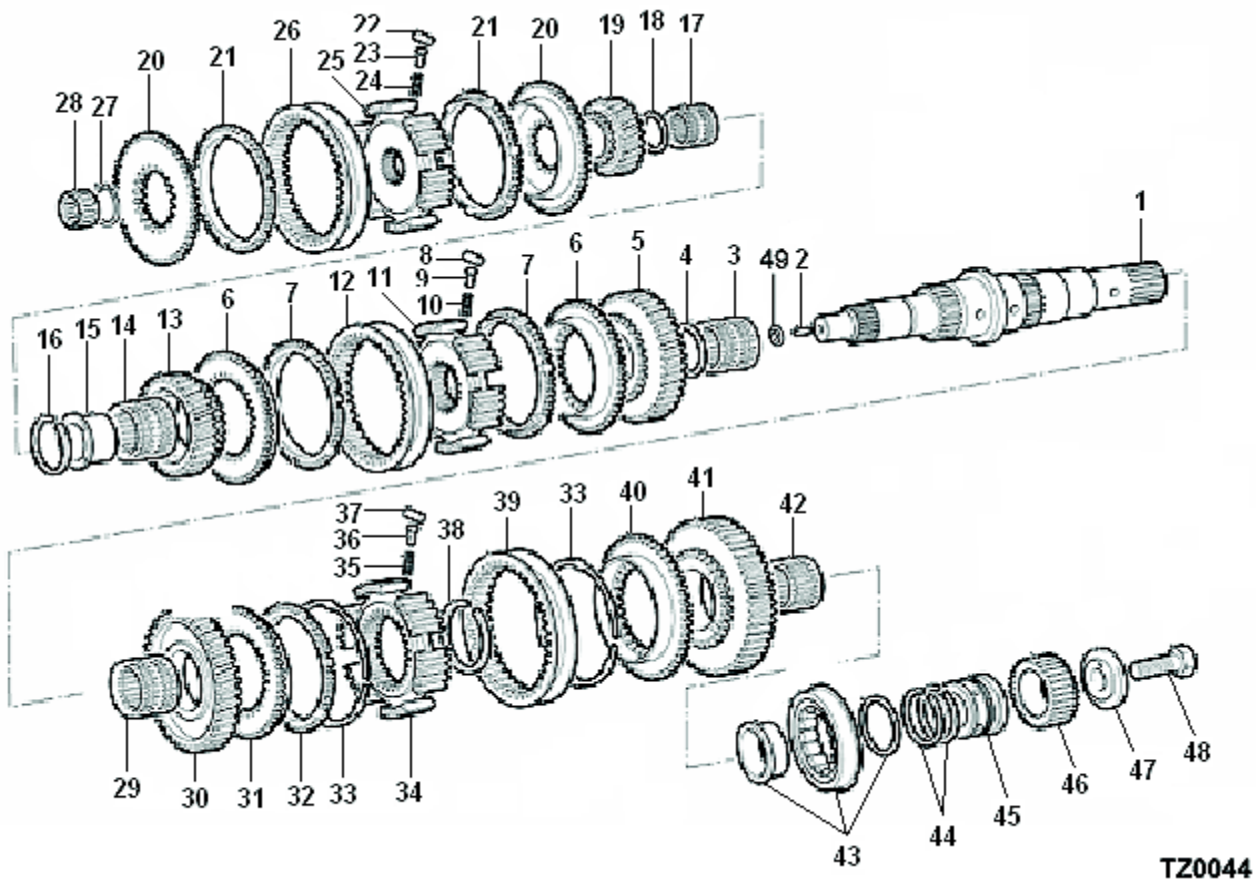

TZ0044

## MAINSHAFT ASSY.

Item	Current Part	Description	Replaced Part	Qty.	Notes	Kits/Assys Where Needed
0	U8883004	MAINSHAFT ASSY.		1		
1	U8877186V	MAINSHAFT SUB ASSY.	U8877186	1		
2	X14851	DOWEL		1	5/16 DI X 1.50	
3	X8870177	NEEDLE ROLLER BRG. ASSY		1		
4	8872589	GEAR SPACER 1ST		1		
5	8876948	GEAR MAINSHAFT 1ST		1		
6	8877321	SYNCHRO FLANGE 1/2/3/4		2		
7	8883044	RING SYNCHRO 1ST/2ND	8882682	2		
8	X8870356	ROLLER		3		
9	8870352	PLUNGER		3		
10	8870444	SPRING COMPRESSION		3		
11	8875571	HUB-FIXED, 1ST/2ND		1		

Item	Current Part	Description	Replaced Part	Qty.	Notes	Kits/Assys Where Needed
12	8880460	SLIDING SLEEVE		1		
13	8876949	GEAR MAINSHAFT 2ND		1		
14	X8870177	NEEDLE ROLLER BRG. ASSY		1		
15	8882868	SLEEVE MAINSHAFT BEARING		1		
16	U8882558	GRADED CIRCLIP PACK		1		
16	X8870534	GR.CIRCLIP 46 DIA. X 2.10 MM		1	PACK: U8882558	
16	X8870535	GR.CIRCLIP 46 DIA. X 2.05 MM		1	PACK: U8882558	
16	X8870536	GR.CIRCLIP 46 DIA. X 2.00 MM		1	PACK: U8882558	
16	X8883040	CIRCLIP GRADED 46 DIA X2.15 MM		1	PACK: U8882558	
16	X8883041	CIRCLIP GRADED 46 DIA X 2.20 MM		1	PACK: U8882558	
17	X8875276	NEEDLE BEARING		1		
18	8872588	GEAR SPACER 4TH		1		
19	8882507	GEAR MAINSHAFT 3RD		1		
20	8877321	SYNCHRO FLANGE 1/2/3/4		2		
21	8883044	RING SYNCHRO 1ST/2ND	8882682	2		
22	X8870356	ROLLER		3		
23	8870352	PLUNGER		3		
24	8870444	SPRING COMPRESSION		3		
25	8875554	FIXED HUB 3RD/4TH		1		
26	8880460	SLIDING SLEEVE		1		
27	U8877531	GRADED CIRCLIP PACK		1		
27	X8870370	GR.C/CLIP 40 DIA. X 2.12 MM		1		
27	X8870371	GR.C/CLIP 40 DIA. X 2.07 MM		1		
27	X8870372	GR.C/CLIP 40 DIA X 2.02 MM		1		
28	X8870305	NEEDLE BRG.ROLLER ASSY		1		
29	X8870177	NEEDLE ROLLER BRG. ASSY		1		



Item	Current Part	Description	Replaced Part	Qty.	Notes	Kits/Assys Where Needed
30	8876477	GEAR MAINSHAFT CRAWLER		1		
31	8877316	SYNCHRO FLANGE		1		
32	8877313	SYNCHRO RING		1		
33	X8873994	CIRCLIP SYNCHRO. ASSY.		1		
34	8875604	FIXED HUB REVERSE/CRAWLER		1		
35	8870444	SPRING COMPRESSION		3		
36	8870352	PLUNGER		3		
37	X8870356	ROLLER		3		
38	U8877532	GRADED CIRCLIP PACK		1		
38	X8870378	CIRCLIP-GR.DIA.60 X 2.10 MM		1		
38	X8870379	CIRCLIP-GR.DIA.60 X 2.05 MM		1		
38	X8870380	CIRCLIP-GR.DIA.60 X 2.00 MM		1		
39	8880461	SLIDING SLEEVE		1		
40	8870415	SYNCHRO FLANGE REVERSE		1		
41	8876478	GEAR MAINSHAFT REVERSE		1		
42	X8870178	NEEDLE ROLLER BRG. ASSY		1		
43	X8877164	BEARING REAR MAINSHAFT		1		
44	X8875532	SEALING RING		2		
45	8877115	OIL MUFF		1		
46	8881203	SUN GEAR		1		
47	8880594	RETAINER		1		
48	GX8870699	SCREW		1	M16X45 HEX HD	
49	8876298	RESTRICTOR		1		

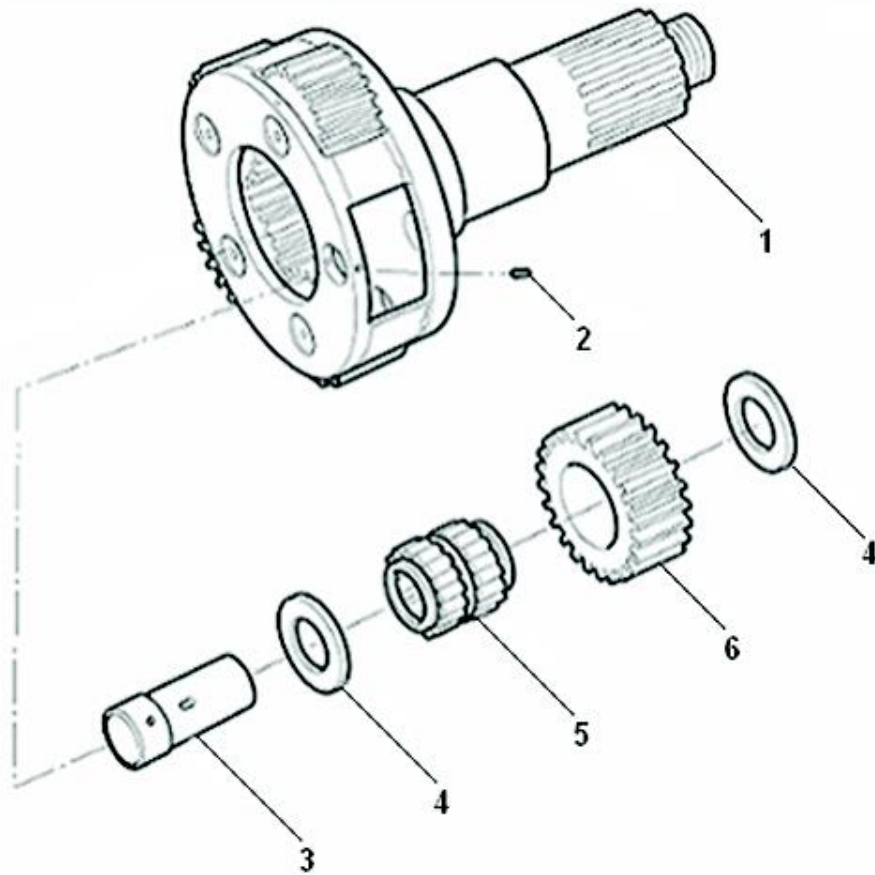

**TZ0008**

**PLANET GEAR SPINDLE ASSY.**

Item	Current Part	Description	Replaced Part	Qty.	Notes	Kits/Assys Where Needed
0	U8880229	PLANET GEAR SPINDLE ASSY		1		
1	U8882529	OUTPUT SHAFT ASSY.		1		
2	MX-11-0601	SCREW		5	M6 X 10 SKT HD SET	
3	8876972	SPINDLE PLANET GEAR		5		
4	8876893	WASHER		10		
5	U8876969	NEEDLE ROLL BRG. ASSY. PCK.		5		
6	8881523	GEAR PLANET		5		

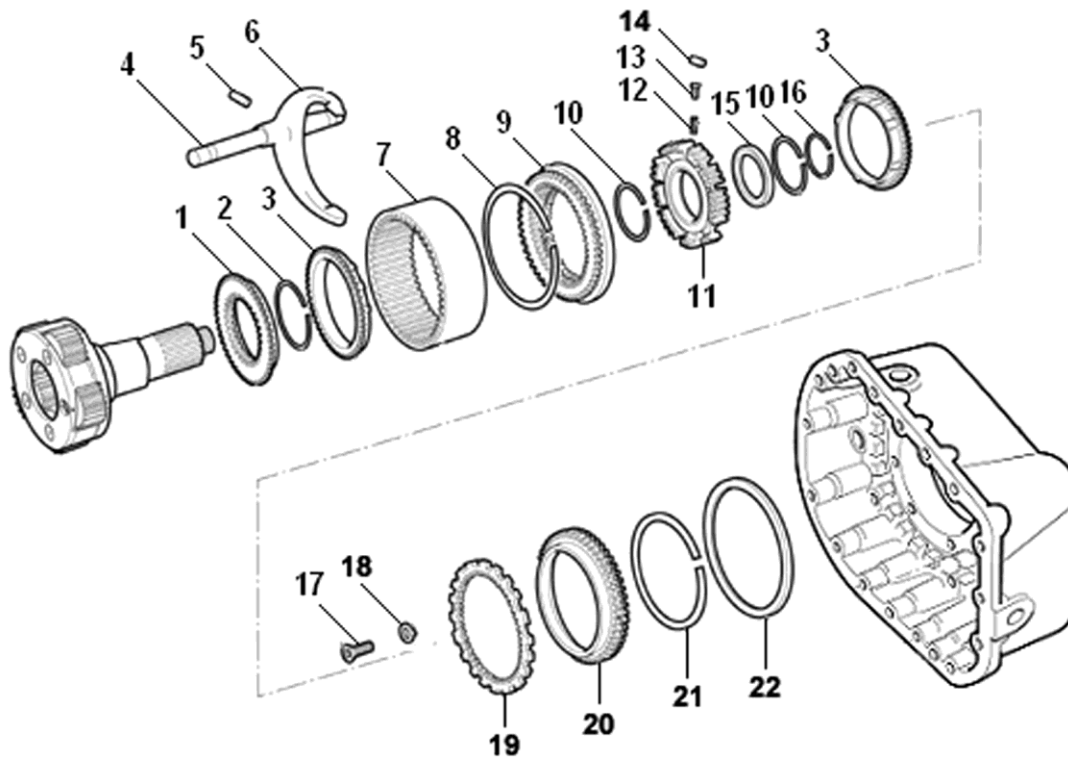

**TZ0033**

**RANGE ASSY.**

Item	Current Part	Description	Replaced Part	Qty.	Notes	Kits/Assys Where Needed
0	U8883422	RANGE ASSY.		1		
1	8877323	SYNCHRO FLANGE		1		
2	X8870342	CIRCLIP		1		
3	8877442	SYNCHRO RING - RANGE		2		
4	8876859	SHIFT ROD - RANGE		1		
5	X8878665	DOWEL	X8870726	1	ECO-0015293	
6	8872737	HIGH/LOW SHIFT FORK	8872737,8883677	1		
7	8880231	ANNULUS		1		
8	X8875296	CIRCLIP		1		
9	8883372	SLIDING SLEEVE		1		
10	X8870341	CIRCLIP		1		
11	8875881	FIXED HUB		1		
12	8870444	SPRING COMPRESSION		9		
13	8870352	PLUNGER		9		
14	X8870355	ROLLER		9		

Item	Current Part	Description	Replaced Part	Qty.	Notes	Kits/Assys Where Needed
15	X8870844	BEARING		1		
16	X8870344	CIRCLIP		1		
17	GMX-8-0806	SCREW		3	M8X20	
18	8870848	RETAINER		3		
19	8875646	REACTION PLATE		1		
20	8877322	SYNCHRO FLANGE		1		
21	X8873993	CIRCLIP		1		
22	8870808	SPACER		1		

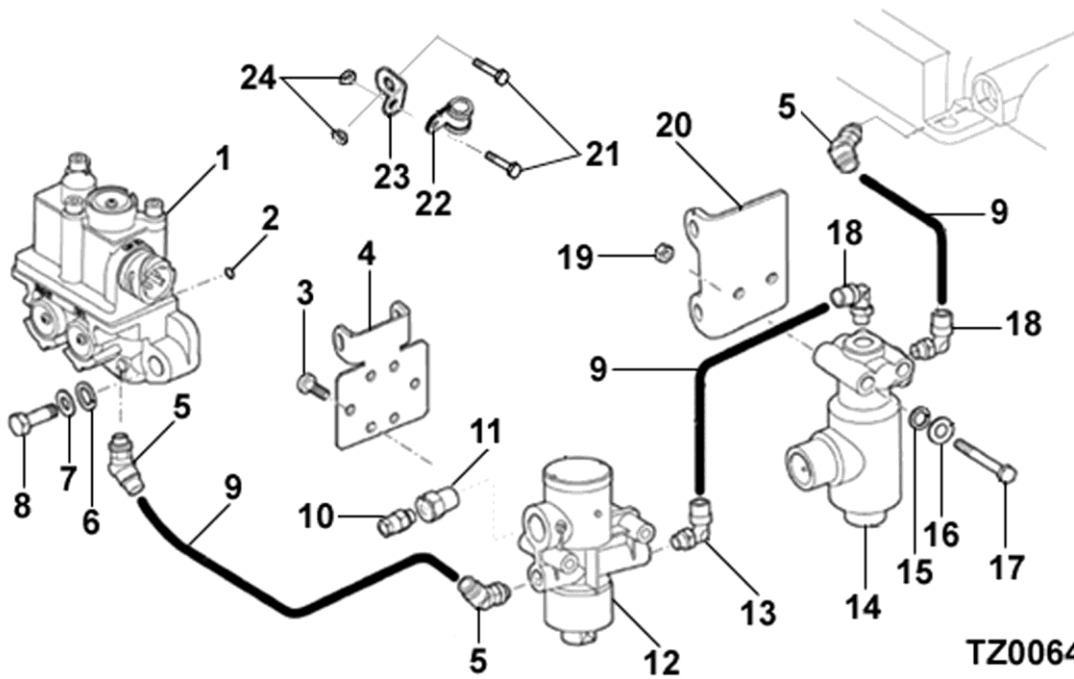

## RANGE CONTROL ASSY.

Item	Current Part	Description	Replaced Part	Qty.	Notes	Kits/Assys Where Needed
0	U8882509	RANGE CONTROL ASSY.		1		
1	U2773023	EPS/R-UNIT MODULE/ELECTROPNEU M		1		
2	15114	O-RING		2		
3	X8880151	SCREW SPIRAL	GX8880151	2		
4	8880659	MOUNTING BRACKET		1		
5	X8881544	SWIVEL ELBOW ADAPTOR 45 DEG		3		
6	GMX-10-0801	WASHER		2	M8	
7	GMX-3-0801	WASHER SPRING		2	M8	
8	GMX-8-0813	BOLT		2	M8 X 35 HX HD	
9	X8881545	NYLON TUBE 6 MM		3		
10	X8881897	STRIGHT ADAPTOR		1	6 MM VOSS 230	
11	X8877156	STRAIGHT ADAPTOR		1	3/8 - M10	
12	X8880109	FILTER REGULATOR		1		

Item	Current Part	Description	Replaced Part	Qty.	Notes	Kits/Assys Where Needed
13	X8880846	ELBOW ARTICULATED		1		
14	X8880184	3/2 SOLENOID VALVE		1		
15	GMX-10-0601	WASHER		2	M6	
16	GMX-3-0602	WASHER SPRING		2	M6	
17	GMX-8-0603	BOLT		2	M6 X 55	
18	X8881591	SWIVEL ELBOW ADAPTOR		2	90 DEG	
19	GMX-9-0601	NUT		2	M4 X 1	
20	8880769	MOUNTING BRACKET		1		
21	GMX-8-1088	SCREW		2	M12X25 HEX FLG HD	
22	8876407	CLAMP HOSE		2		
23	GX8879212	LIFTING EYE		2	15 MM	
24	GMX-9-1005	NUT		2	M10X1.5	

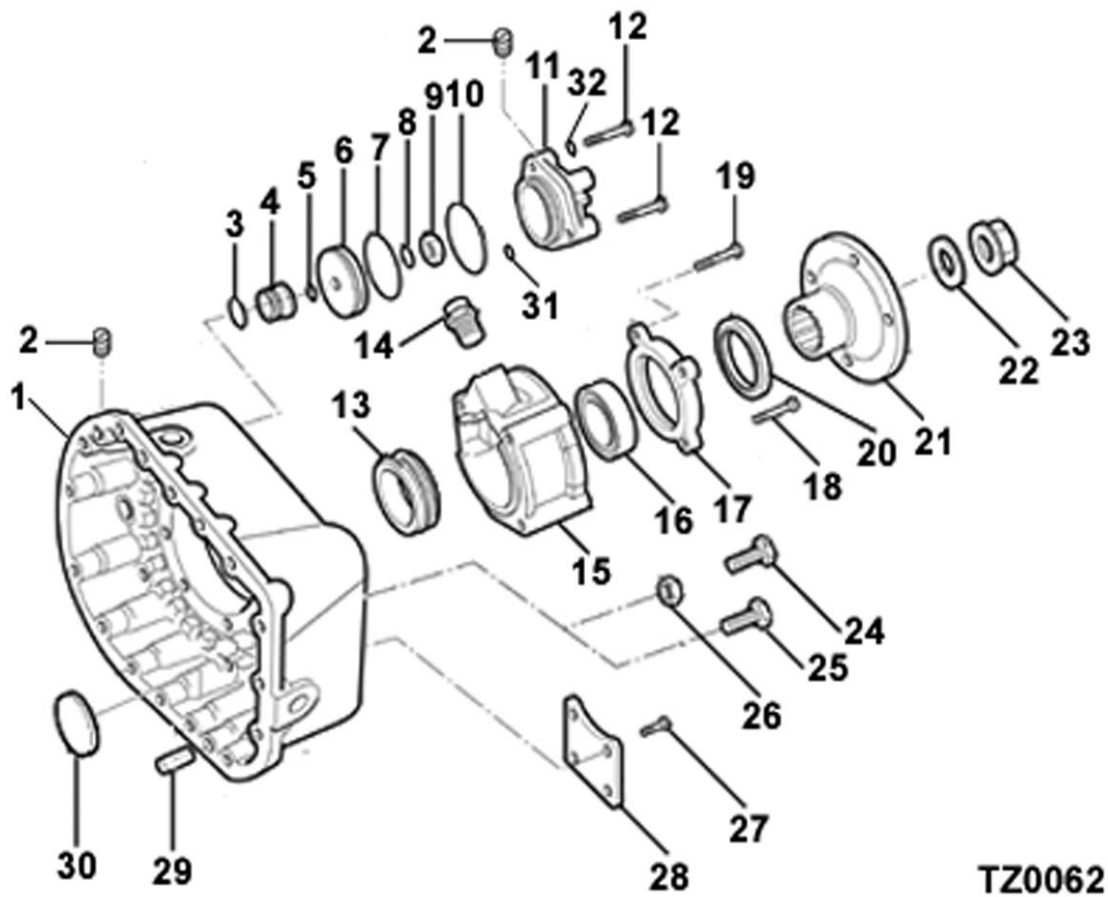

TZ0062

### REAR CASE ASSY.

Item	Current Part	Description	Replaced Part	Qty.	Notes	Kits/Assys Where Needed
0	U8881469	REAR CASE ASSY.		1		
1	8881471	REAR CASING		1		
2	GMX-8-0857	PLUG		2	M8 X 1.25	
3	X8875292	O-RING		1		
4	8878240	BUSH	8875293	1		
5	X8871258	O-RING		1	DIA.24,5	
6	8875179	PISTON RANGE CYLINDER		1		
7	14344	PISTON O RING		1		
8	14345	PISTON O RING		1		
9	GMX-9-1602	NUT		1	M16	
10	X8873008	O-RING		1		

Item	Current Part	Description	Replaced Part	Qty.	Notes	Kits/Assys Where Needed
11	8882369	CYLINDER RANGE		1		
12	GMX-8-1084	BOLT		1	M10 X 80	
12	GMX-8-1094	BOLT		2	M10X55 HEX FLG HD	
13	8882428	TACHOGRAPH ROTOR		1		
14	X8883716	SPEEDO SENSOR	GX8882393	1		
15	8874013	ELECTR. SPEEDO HOUSING		1		
16	X8872721	BEARING		1		
17	8871992	REAR COVER		1		
18	GMX-8-1095	BOLT		3	M10X95 HEX FLG HD	
19	GMX-8-1096	BOLT		1	M10X95 HEX FLG HD	
20	X8872722	OIL SEAL		1		
21	GX8877225	COUPLING FLANGE		1		
22	8877209	SPACER		1	77 X 61 X 6	
23	GX8870553	NUT		1		
24	GMX-8-1080	BOLT		13	M10X58	
25	GMX-8-10111	BOLT		4	M10X65 HEX FLG HD	
26	GMX-9-1005	NUT		17	M10X1.5	
27	GMX-8-1240	SCREW		4	M12X25 HEX FLG HD	
28	GX8873917	LAYSHAFT REAR COVER		1		
29	X8870543	DOWEL		2	16,0 DI X 30,5	
30	14373	DISC MAGNET		1		
31	15114	O-RING		1		
32	GX11245	WASHER PLAIN		1	M10	



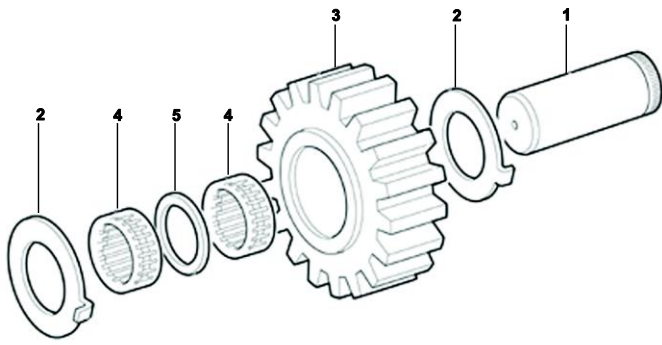

TZ0007

## REVERSE IDLER ASSY.

Item	Current Part	Description	Replaced Part	Qty.	Notes	Kits/Assys Where Needed
1	8883246	REVERSE IDLER SHAFT		1		
2	8870343	THRUST WASHER		2		
3	8876457	REVERSE IDLER GEAR		1		
4	X8872478	NEEDLE ROLLER BRG		2		
5	8872479	SPACER		1		

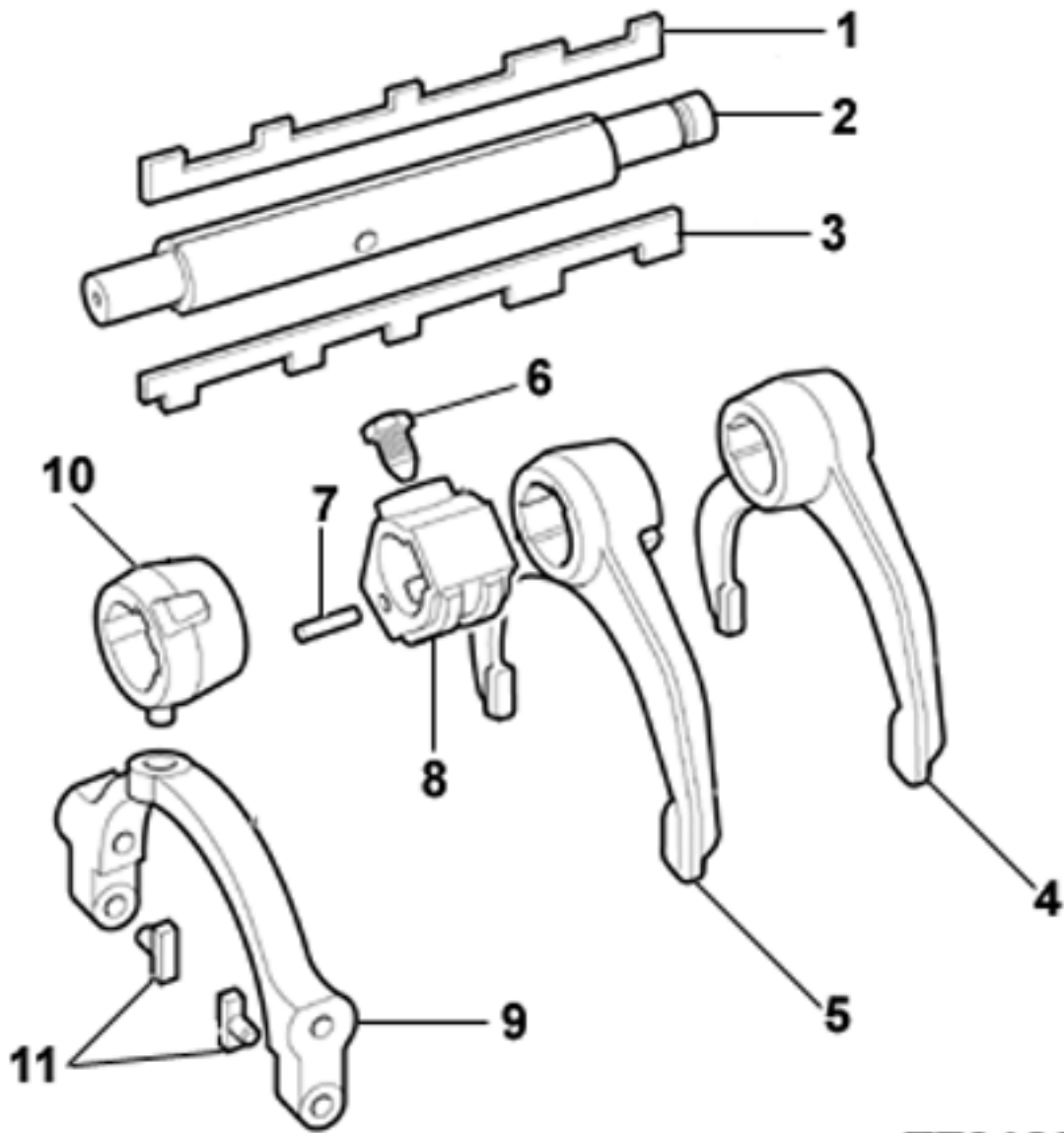

**TZ0126**

**SELECTOR ASSY. O/D**

Item	Current Part	Description	Replaced Part	Qty.	Notes	Kits/Assys Where Needed
0	U8877614	SELECTOR ASSY. O/D		1		
1	8872328	SELECTOR KEY		1		
2	8882443	SELECTOR SHAFT	8875827	1		
3	8880759	INTERLOCK KEY	8872327	1		
4	8875499	FORK CRAWLER/REVERSE		1		
5	8880760	FORK 1ST/2ND		1		

Item	Current Part	Description	Replaced Part	Qty.	Notes	Kits/Assys Where Needed
6	8873691	SCREW		1	M10X23 HEX HD	
7	X8870277	DOWEL		1		
8	8874755	SELECTOR BLOCK		1		
9	8876856	FORK OVERDRIVE		1		
10	8877613	SELECTOR OVERDRIVE		1		
11	8872042	PAD SHIFT FORK		2		

Copyright Eaton Corporation, 2009.  
Eaton hereby grants their customers,  
vendors, or distributors permission to  
freely copy, reproduce and/or distribute  
this document in printed format. It may  
be copied only in its entirety without  
any changes or modifications. THIS  
INFORMATION IS NOT INTENDED FOR  
SALE OR RESALE, AND THIS NOTICE  
MUST REMAIN ON ALL COPIES.

