



Powering Business Worldwide

Illustrated Parts List

Y04332

November 2015

Contents

How To Use The Illustrated Parts List	3
DIRECT CONTROL ASSY.....	4
FRONT BEARING COVER ASSY.	6
FRONT CASE ASSY.....	7
INPUT SHAFT ASSY.....	9
LAYSHAFT ASSY.	10
MAINSHAFT ASSY.....	12
REAR CASE ASSY.	15
REVERSE IDLER SHAFT.....	17
SELECTOR ASSY.	18
SPEEDO HOUSING.....	20

How To Use The Illustrated Parts List

The information contained in this document is subject to frequent updates. Therefore, for the latest information available, please visit the interactive Electronic Parts Catalog at <http://www.eaton.com/EatonCom/TruckEurope/TruckEurope/index.htm>

Model Designation and Nomenclature

- For information regarding Model Designation and Nomenclature, visit <http://www.eaton.com/EatonCom/TruckEurope/TruckEurope/index.htm>

Kits and Assemblies (K/A's)

- Kits or Assemblies contain groups of individual or assembled parts specially developed for optimal replacement during repair.
- Kits and Assemblies are shown with applicable parts groupings in the parts listings.

Identifying Kits and Assemblies

A- Part numbers beginning with the letter 'A' are pre-assembled Production Assemblies

K- Part numbers beginning with the letter 'K' are kits that are not assembled

T - Part numbers beginning with the letter 'T' are kits that are not assembled

S- Part numbers beginning with the letter 'S' are pre-assembled Service Assemblies

- Note: Some Production Assemblies do not begin with a letter prefix (Midrange only).

Illustrations

- Illustrations show parts in assembly groups.
- Item numbers on illustrations correspond with parts listings adjacent to the illustration.(on the same or adjacent page)
- Notes are included on illustrations where additional information is needed.

Parts Listing

Parts listings are defined by parts groupings and are broken down by service assemblies. Parts listings identify a part for servicing with the following categories

- **ITEM** - Number corresponds to number on illustration for part identification.
- **CURRENT PART** - part number of the part available for service.
- **DESCRIPTION** - part name or description.
- **REPLACED PART** - number of replaced part.
- **QTY** - Quantity required for assembly.
- **NOTES** - unique characteristics or requirements.
- **KITS / ASSYS WHERE NEEDED** - kits or assemblies that contain the part.

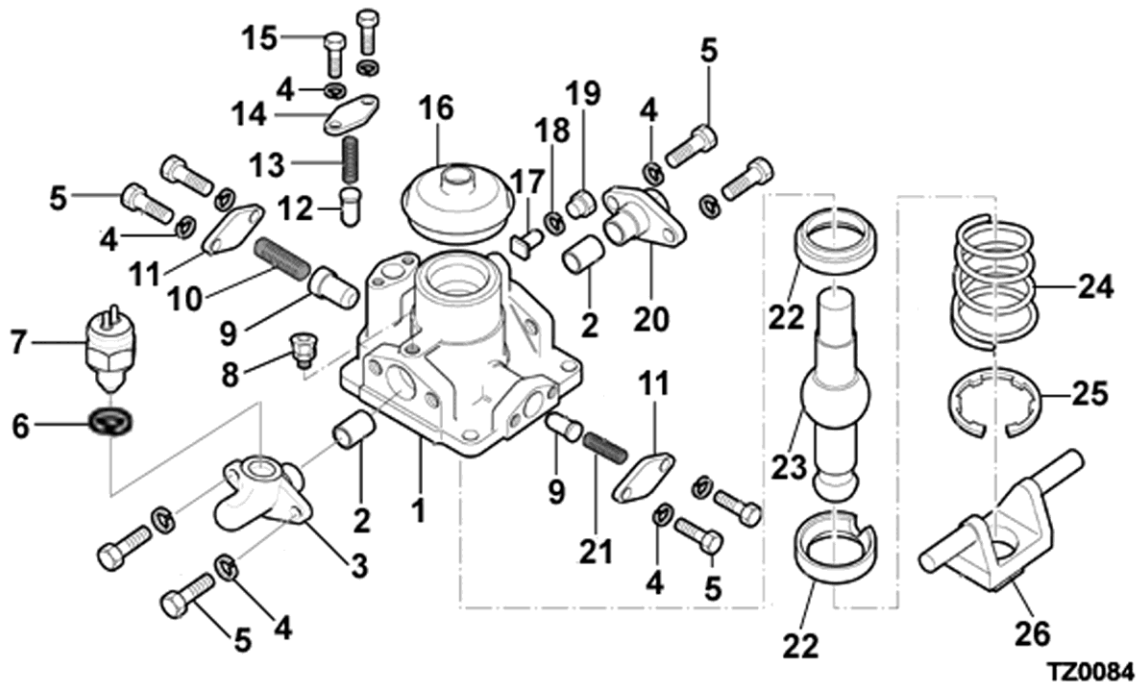

DIRECT CONTROL ASSY.

Item	Current Part	Description	Replaced Part	Qty.	Notes	Kits/Assys Where Needed
0	DU8877428	DIRECT CONTROL ASSY.		1		
1	D8877338	HOUSING DIRECT CONTROL		1		
2	8875217	BUSH		2	DIA 12 SPLIT	
3	GX8877437	END CAP		1		
4	GMX-3-0801	WASHER SPRING		8	M8	
5	GMX-8-0803	SCREW		8	M8X25	
6	5568510	O-RING		1		
7	8876415	NEUTRAL SWITCH		1		
8	DX8877268	ADAPTOR		1	1/8" NPT 6 MM	
9	8875205	PLUNGER BIAS		2		
10	8875351	SPRING COMPRESSION		1		
11	GX8875210	COVER		2		
12	8875206	PLUNGER REVERSE DETENT		1		

Item	Current Part	Description	Replaced Part	Qty.	Notes	Kits/Assys Where Needed
13	8870587	DETENT SPRING		1		
14	GX8875209	COVER		1		
15	GMX-8-0811	SCREW		2	M8X20	
16	8876548	GAITER DIRECT CONTROL		1		
17	8875208	PIN PIVOT		1		
18	GX8880158	WASHER		1	M10 SELF CENTRING	
19	GX8875207	PLUG		1	M10	
20	GX8875203	END CAP		1		
21	8877439	SPRING COMPRESSION		1		
22	8876568	SEATING SPHERICAL		2		
23	GX8876565	GEAR LEVER		1		
24	8876894	SPRING CONICAL		1		
25	8872401	SPRING RETAINER		1		
26	8877438	YOKE		1		

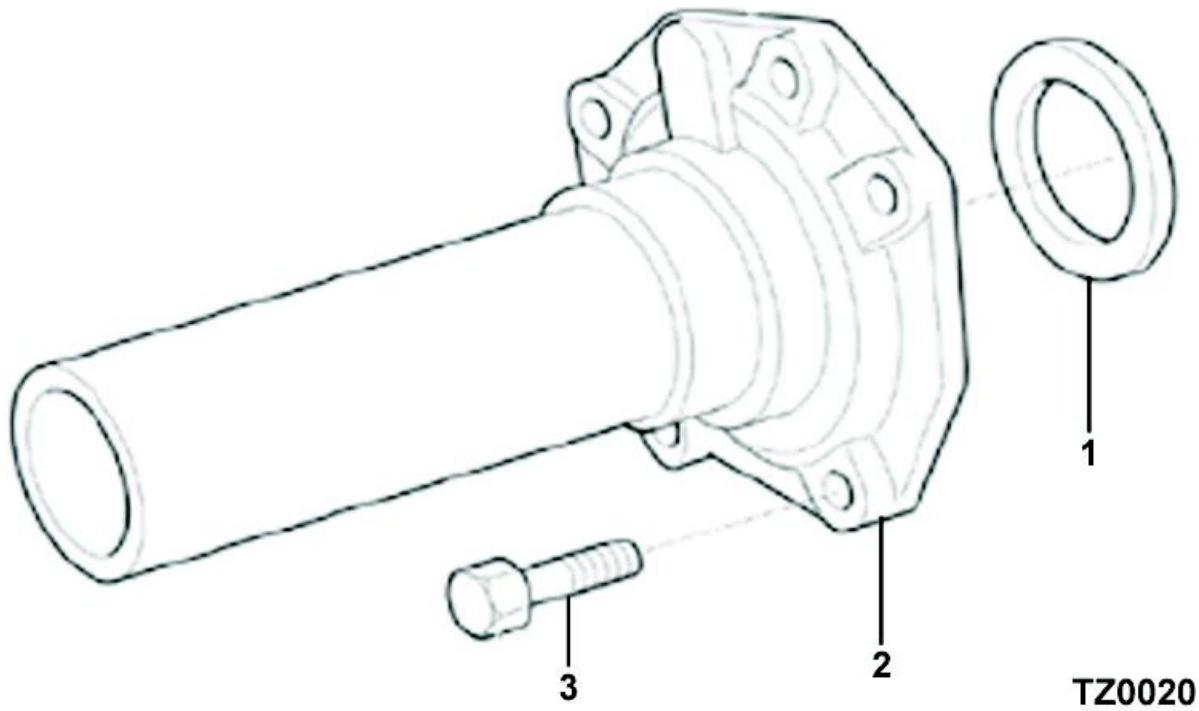

FRONT BEARING COVER ASSY.

Item	Current Part	Description	Replaced Part	Qty.	Notes	Kits/Assys Where Needed
0	U8872546	FRONT BEARING COVER ASSY.		1		
1	X8870760	OIL SEAL		1		
2	8872547	FRONT BEARING COVER		1		
3	GMX-8-1089	SCREW		5	M10X25 HEX FLG HD	

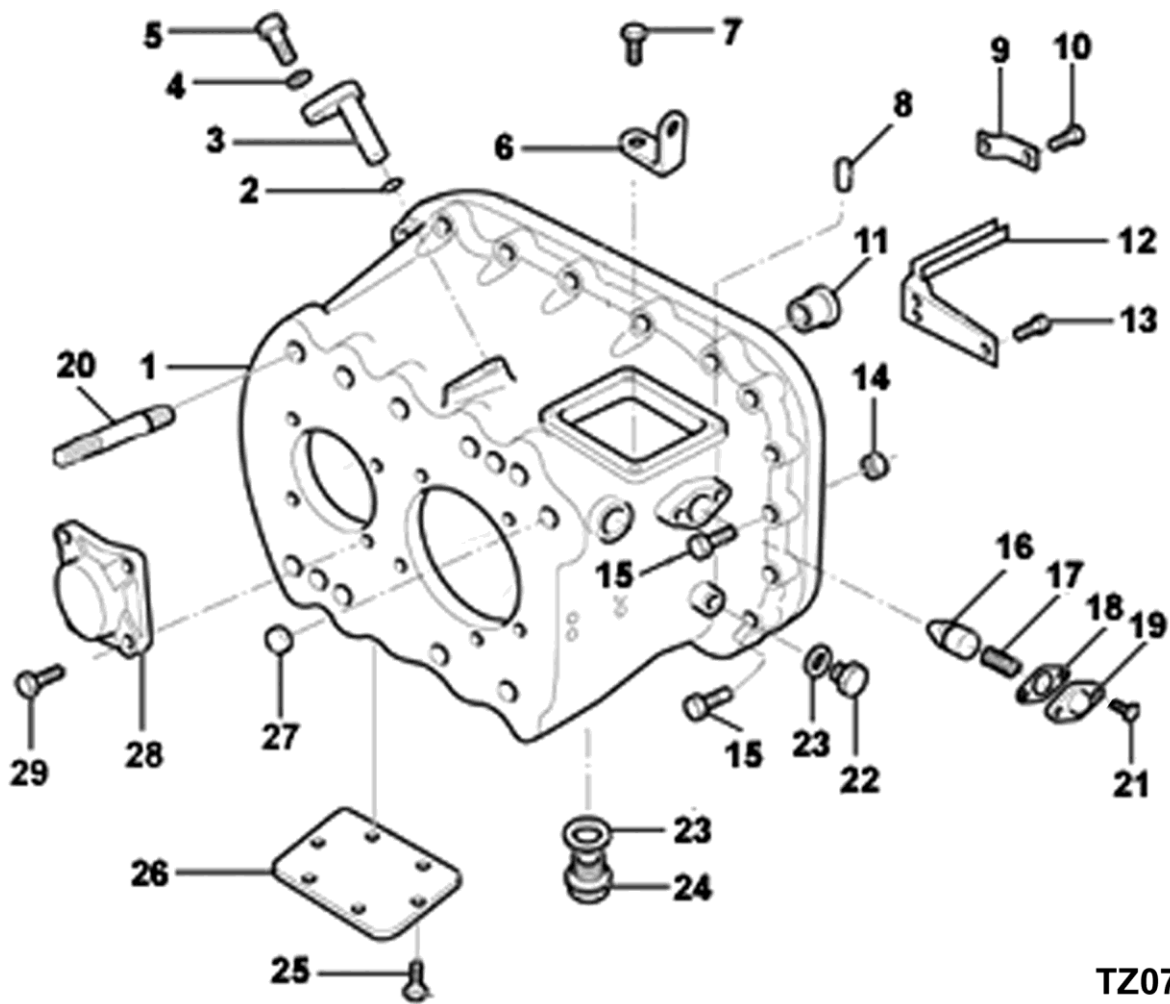

TZ0746

FRONT CASE ASSY

Item	Current Part	Description	Replaced Part	Qty.	Notes	Kits/Assys Where Needed
0	U8882256	FRONT CASE ASSY.		1		
1	U8881865	FRONT CASE		1		
2	X8877743	O-RING		2	11.1 ID X 1.6 DIA	
3	GX8872917	ROTATION PIN O/D FORK		2		
4	GMX-3-0801	WASHER SPRING		2	M8	
5	GMX-8-0811	SCREW		2	M8X20	
6	GX8879212	LIFTING EYE		1	15 MM	
7	GMX-8-1091	SCREW		4	M10X30 HEX FLG HD	
8	X8870542	DOWEL		2	8,0 DIA X 16	
9	8877430	OIL TROUGH		1		

Item	Current Part	Description	Replaced Part	Qty.	Notes	Kits/Assys Where Needed
10	X8872604	SCREW		2		
11	8883756	BUSH	8882415	1	FOR MAIN SELECTOR SHAFT	
12	8877431	OIL TROUGH		1		
13	8874473	SCREW		3		
14	GMX-9-1005	NUT		15	M10X1.5	
15	GMX-8-1079	BOLT		3	M10X40	
15	GMX-8-1080	BOLT		15	M10X58	
16	8873654	PLUNGER-NEUTRAL		1		
17	8876679	SPRING COMPRESSION		1		
18	8870590	GASKET		1		
19	GX8870259	DETENT COVER		1		
20	GX8873931	STUD		8	M12X45 LONG	
20	GX8874699	STUD	GX8881103	2	M12X65 LONG	
21	GMX-8-0819	SCREW	GMX-8-0801	2	M8 X 16	
22	GX8874942	OIL FILLER PLUG		1		
23	X8880519	WASHER-FILL/DRAIN FL		2		
24	GX8874941	MAGNETIC PLUG		1	M24	
25	GMX-8-1088	SCREW		6	M12X25 HEX FLG HD	
26	8881616	PTO PROVISION COVER		1		
27	GX8870278	CUP PLUG		1		
28	GX8880554	BEARING COVER LAYSHAFT		1		
29	GMX-8-1240	SCREW		4	M12X25 HEX FLG HD	

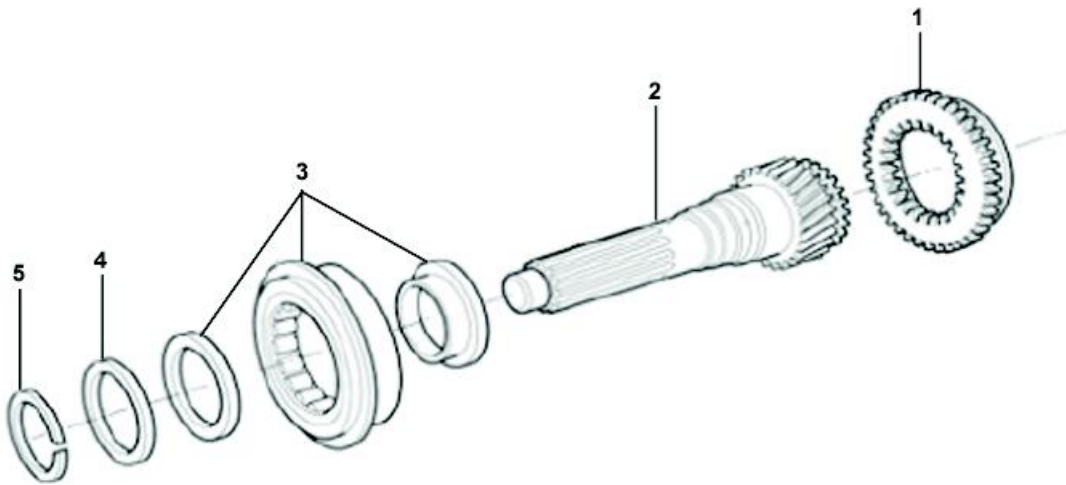

TZ0019

INPUT SHAFT ASSY.

Item	Current Part	Description	Replaced Part	Qty.	Notes	Kits/Assys Where Needed
0	U8877939	INPUT SHAFT ASSEMBLY		1		
1	8877318	SYNCHRO FLANGE		1		
2	8877809	INPUT SHAFT		1		
3	X8872593	INPUT SHAFT BEARING		1		
4	8877692	SPACER - GRADED 3.10		1	PACK: U8877691	
4	8877693	SPACER - GRADED 3.15		1	PACK: U8877691	
4	8877694	SPACER - GRADED 3.20		1	PACK: U8877691	
4	8877695	SPACER - GRADED 3.25		1	PACK: U8877691	
4	8877696	SPACER - GRADED 3.30		1	PACK: U8877691	
4	8877697	SPACER - GRADED 3.35		1	PACK: U8877691	
4	8877698	SPACER - GRADED 3.40		1	PACK: U8877691	
4	8877699	SPACER - GRADED 3.45		1	PACK: U8877691	
4	8877700	SPACER - GRADED 3.50		1	PACK: U8877691	
4	U8877691	SPACER - GRADED PACK		1		
5	X8877706	CIRCLIP		1		

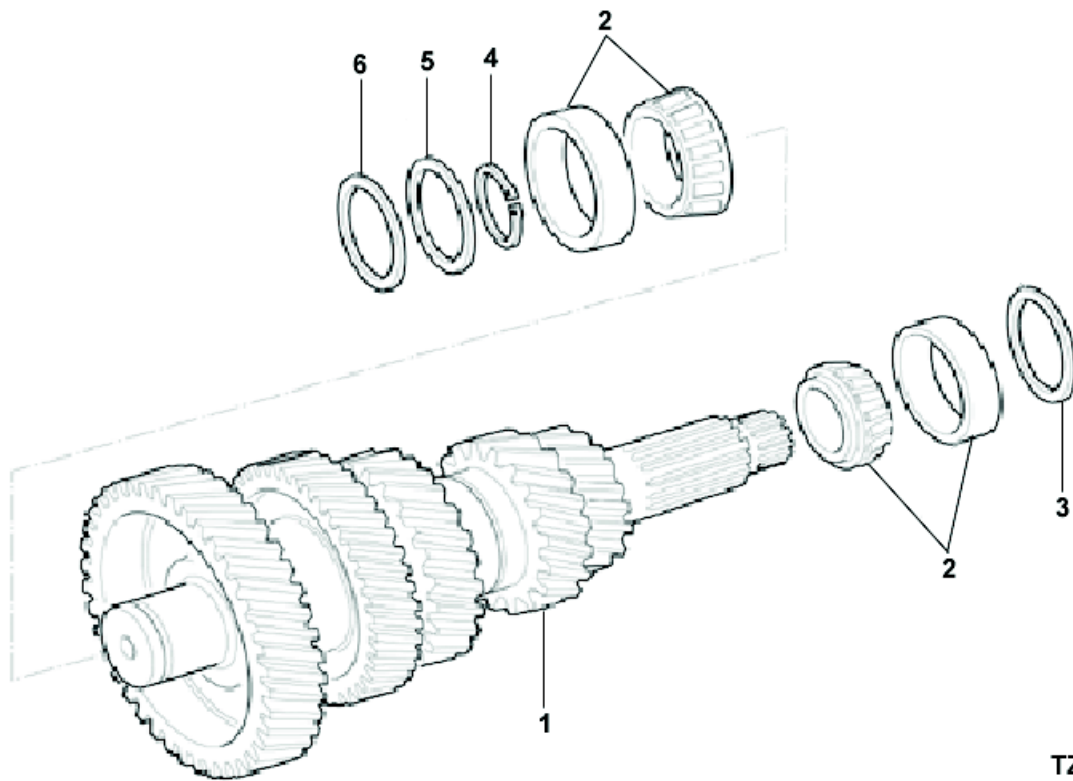

TZ0023

LAYSHAFT ASSY.

Item	Current Part	Description	Replaced Part	Qty.	Notes	Kits/Assys Where Needed
1	U8880064	LAYSHAFT ASSY.		1		
2	X8875587	BEARING ASSEMBLY		2		
3	8872210	DISTANCE PIECE		1		
4	U8877534	CIRCLIP GRADED PACK		1		
4	X8870370	GR.C/CLIP 40 DIA. X 2.12 MM		1		
4	X8870371	GR.C/CLIP 40 DIA. X 2.07 MM		1		
4	X8870372	GR.C/CLIP 40 DIA X 2.02 MM		1		
4	X8871536	GR.C/CLIP 40 DIA. X 1.97 MM		1		
4	X8871537	GR.C/CLIP 40 DIA. X 1.92 MM		1		
4	X8871538	GR.C/CLIP 40 DIA. X 1.87 MM		1		
4	X8871539	GR.C/CLIP 40 DIA. X 1.82 MM		1		

Item	Current Part	Description	Replaced Part	Qty.	Notes	Kits/Assys Where Needed
4	X8871540	GR.C/CLIP 40 DIA. X 1.77 MM		1		
5	F88891	SHIM		1	S=0,051	
5	F88892	SHIM		1	S=0,127	
5	F88893	SHIM		1	S=0,254	
5	F88894	SHIM		1	S=0,508	
5	U8877535	SHIM PACK		1		
5	X8882272	SHIM		1	S=1,200	
6	8875879	SPACER		1		

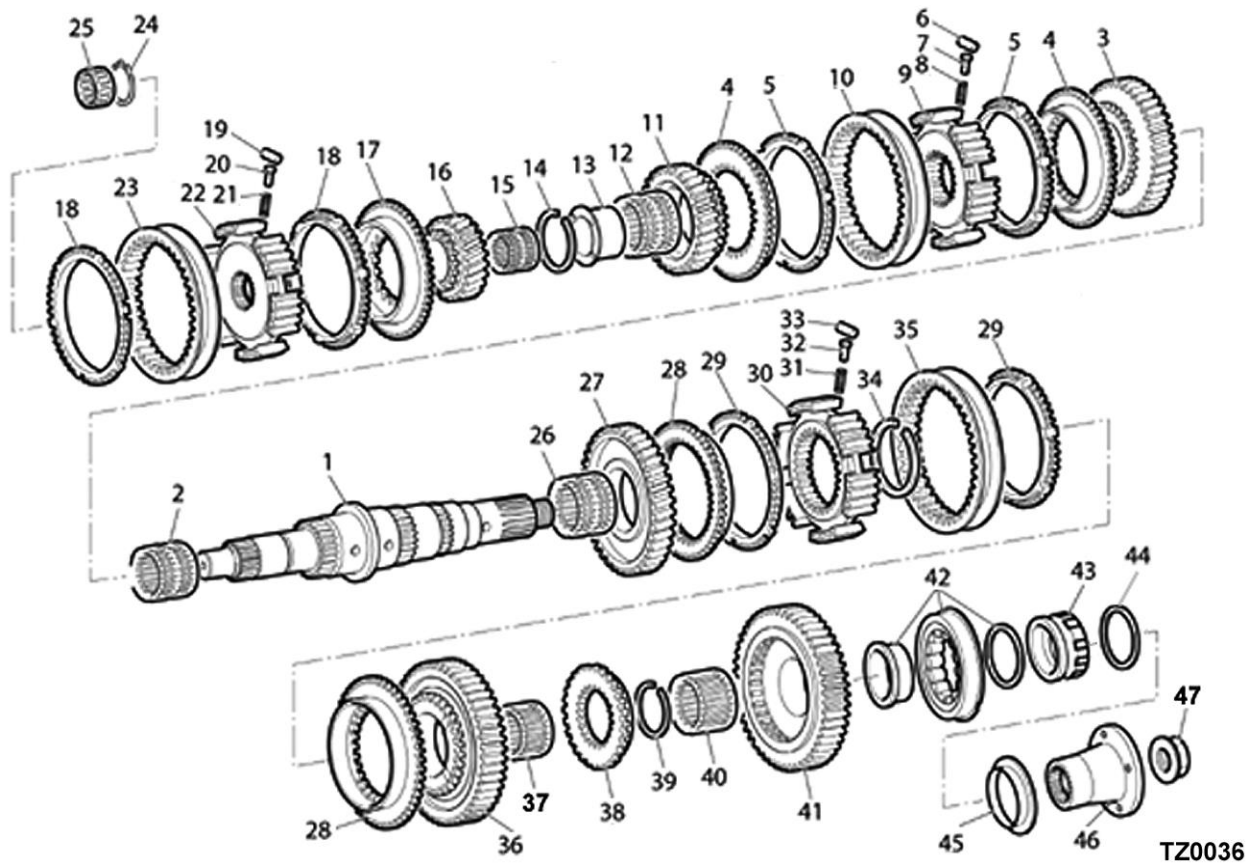

MAINSHAFT ASSY.

Item	Current Part	Description	Replaced Part	Qty.	Notes	Kits/Assys Where Needed
0	U8877902	MAINSHAFT ASSY.		1		
1	8876605	MAINSHAFT		1		
2	X8872236	NEEDLE ROLLER BRG. ASSY.		1		
3	8880491	GEAR MAINSHAFT 3RD	8876267	1		
4	8877316	SYNCHRO FLANGE		2		
5	8877313	SYNCHRO RING		2		
6	X8870356	ROLLER		3		
7	8870352	PLUNGER		3		
8	8870444	SPRING COMPRESSION		3		
9	8875128	FIXED HUB 3RD/4TH		1		
10	8875374	SLIDING SLEEVE		1		
11	8872009	GEAR MAINSHAFT 4TH		1		
12	X8872233	NEEDLE ROLLER BRG.		1		

Item	Current Part	Description	Replaced Part	Qty.	Notes	Kits/Assys Where Needed
		ASSY				
13	8882868	SLEEVE MAINSHAFT BEARING		1		
14	U8882558	GRADED CIRCLIP PACK		1		
14	X8870534	GR.CIRCLIP 46 DIA. X 2.10 MM		1	PACK: U8882558	
14	X8870535	GR.CIRCLIP 46 DIA. X 2.05 MM		1	PACK: U8882558	
14	X8870536	GR.CIRCLIP 46 DIA. X 2.00 MM		1	PACK: U8882558	
14	X8883040	CIRCLIP GRADED 46 DIA X2.15 MM		1	PACK: U8882558	
14	X8883041	CIRCLIP GRADED 46 DIA X 2.20 MM		1	PACK: U8882558	
15	X8870180	NEEDLE BEARING		1		
16	8880088	GEAR MAINSHAFT 6TH	8872028	1		
17	8877317	SYNCHRO FLANGE		1		
18	8877314	SYNCHRO RING		2		
19	X8870356	ROLLER		3		
20	8870352	PLUNGER		3		
21	8870444	SPRING COMPRESSION		3		
22	8875127	FIXED HUB 5TH/6TH		1		
23	8875375	SLIDING SLEEVE		1		
24	U8877531	GRADED CIRCLIP PACK		1		
24	X8870370	GR.C/CLIP 40 DIA. X 2.12 MM		1		
24	X8870371	GR.C/CLIP 40 DIA. X 2.07 MM		1		
24	X8870372	GR.C/CLIP 40 DIA X 2.02 MM		1		
25	X8870305	NEEDLE BRG.ROLLER ASSY		1		
26	X8872236	NEEDLE ROLLER BRG. ASSY.		1		
27	8876904	GEAR MAINSHAFT 2ND	8881309	1		
28	8877315	SYNCHRO FLANGE		2		
29	8877440	SYNCHRO RING		2		
30	8875129	FIXED HUB 1ST/2ND		1		

Item	Current Part	Description	Replaced Part	Qty.	Notes	Kits/Assys Where Needed
31	8870444	SPRING COMPRESSION		3		
32	8870352	PLUNGER		3		
33	X8870356	ROLLER		3		
34	U8876620	GRADED CIRCLIP PACK		1		
34	X8876597	CIRCLIP GR.DIA. 65 X 4.15		1	PACK: U8876620	
34	X8876598	CIRCLIP-GR.DIA. 65 X 4.10		1	PACK: U8876620	
34	X8876599	CIRCLIP-GR.DIA. 65 X 4.05		1	PACK: U8876620	
34	X8876600	CIRCLIP-GR.DIA. 65 X 4.00		1	PACK: U8876620	
34	X8876601	CIRCLIP-GR.DIA. 65 X 3.95		1	PACK: U8876620	
35	8875373	SLIDIND SLEEVE 1ST/2ND		1		
36	8876603	GEAR MAINSHAFT 1ST		1		
37	X8870177	NEEDLE ROLLER BRG. ASSY		1		
38	8876602	HUB FIXED REVERSE		1		
39	U8882193	GRADED CIRCLIP PACK		1		
39	X8870378	CIRCLIP-GR.DIA.60 X 2.10 MM		1		
39	X8870379	CIRCLIP-GR.DIA.60 X 2.05 MM		1		
39	X8870380	CIRCLIP-GR.DIA.60 X 2.00 MM		1		
40	X8870178	NEEDLE ROLLER BRG. ASSY		1		
41	8872013	GEAR MAINSHAFT REVERSE		1		
42	X8877197	BRG.M/S OUTPUT INT SPACER		1		
43	8877149	ROTOR TACHOGRAPH		1		
44	8877150	SPACER TACH0		1		
45	GX8870572	DIRT SHIELD		1		
46	GX8876093	COUPLING FLANGE		1		
47	GX8870564	MAINSHAFT NUT		1	M33	

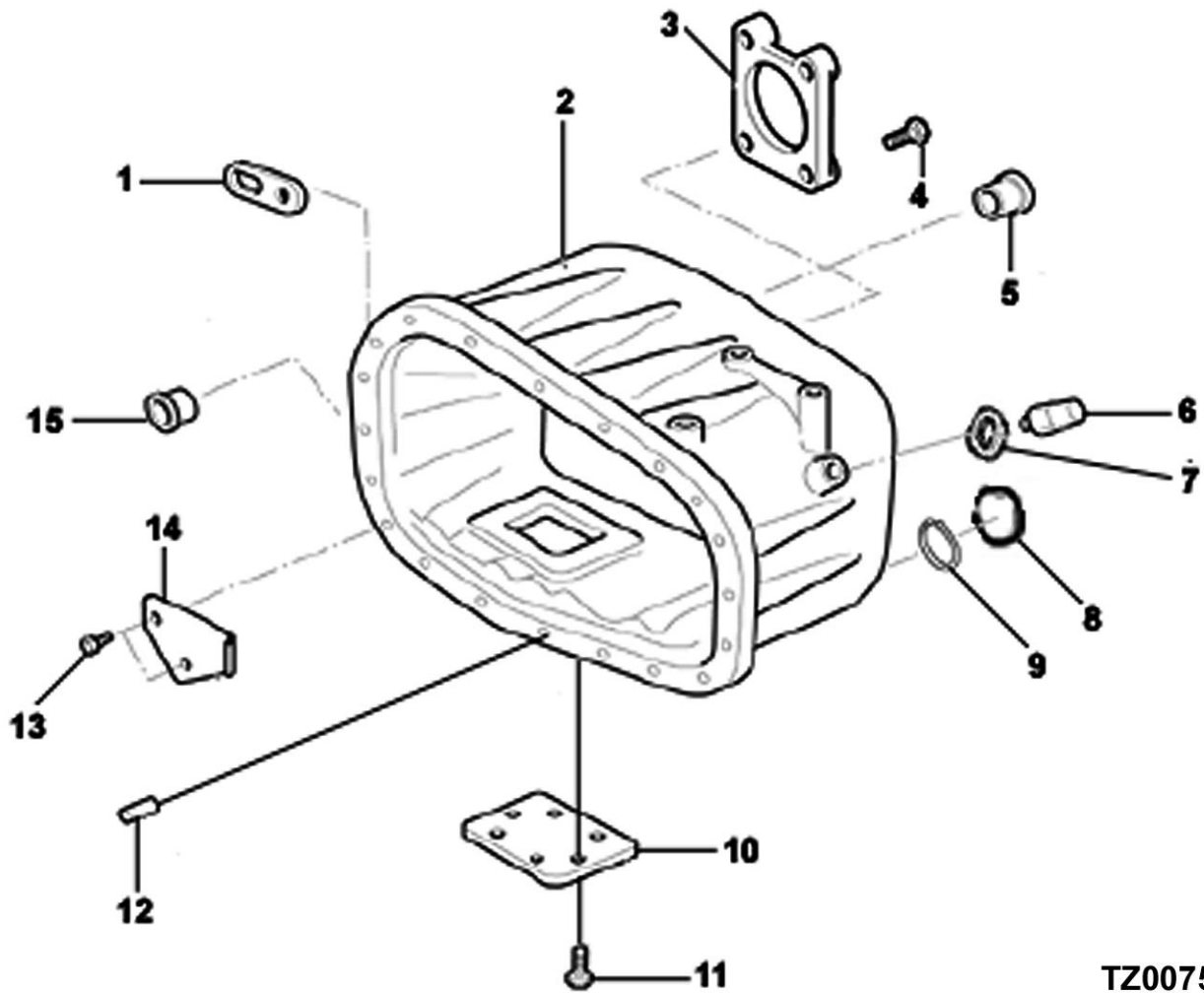

TZ0075

REAR CASE ASSY.

Item	Current Part	Description	Replaced Part	Qty.	Notes	Kits/Assys Where Needed
0	DU8876798	REAR CASE ASSY.		1		
1	GX8879211	LIFTING EYE		2		
2	8876781	REAR CASE		1		
3	GX8880554	BEARING COVER LAYSHAFT		1		
4	GMX-8-1239	SCREW		4	M12 X 25 HEX FLG HD	
5	GX8870278	CUP PLUG		1		
6	8876416	REVERSE SWITCH		1		
7	5568510	O-RING		1		
8	X8880496	CORE PLUG		1	37.DIA	

Item	Current Part	Description	Replaced Part	Qty.	Notes	Kits/Assys Where Needed
9	X8881424	CIRCLIP		1		
10	8881616	PTO PROVISION COVER		1		
11	GMX-8-1088	SCREW		6	M12X25 HEX FLG HD	
12	X8870543	DOWEL		2	16,0 DI X 30,5	
13	8874473	SCREW		2		
14	8874494	PLATE OIL RETENTION		1		
15	8883756	BUSH	8882415	1	FOR MAIN SELECTOR SHAFT	

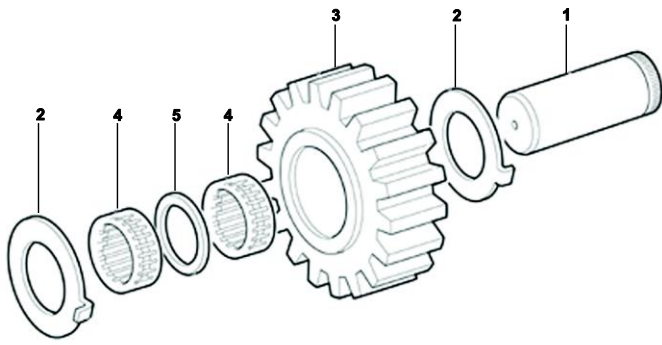

TZ0007

REVERSE IDLER SHAFT

Item	Current Part	Description	Replaced Part	Qty.	Notes	Kits/Assys Where Needed
1	8883246	REVERSE IDLER SHAFT		1		
2	8870343	THRUST WASHER		2		
3	8872173	GEAR IDLER REVERSE		1		
4	X8872478	NEEDLE ROLLER BRG		2		
5	8872479	SPACER		1		

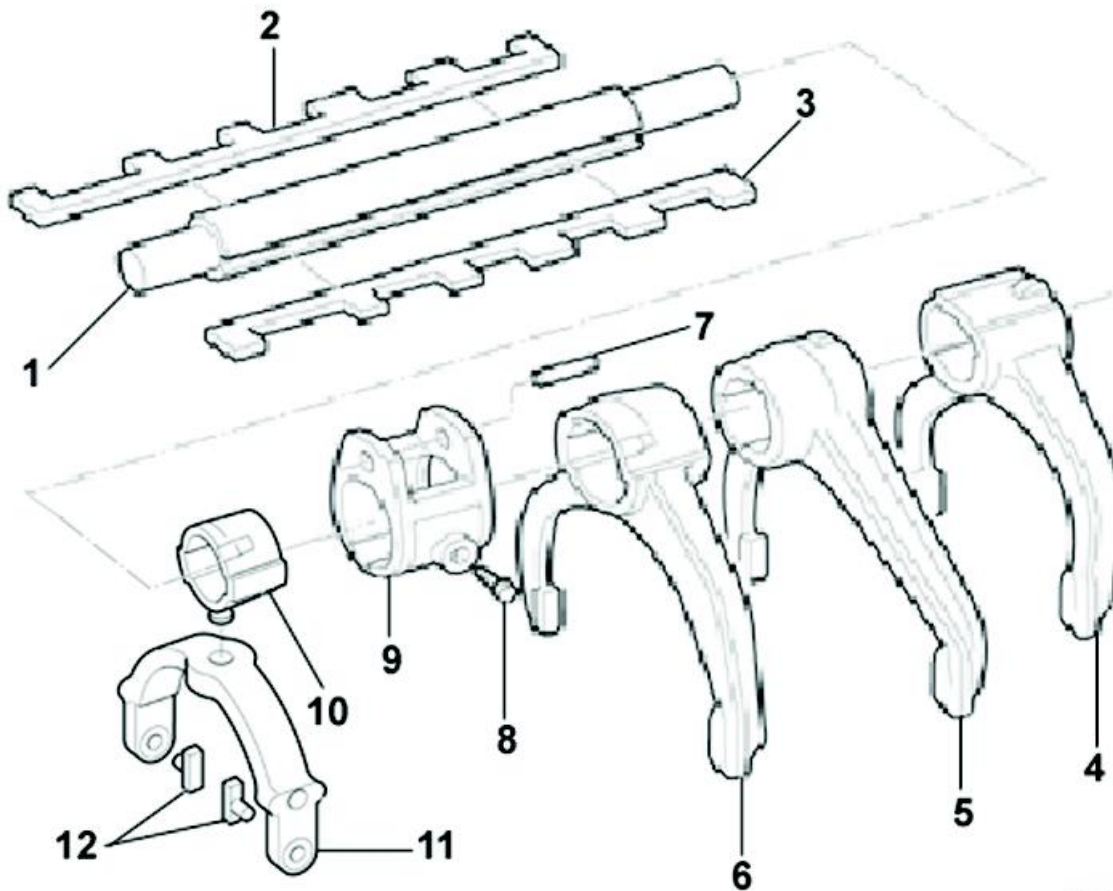

TZ0037

SELECTOR ASSY.

Item	Current Part	Description	Replaced Part	Qty.	Notes	Kits/Assys Where Needed
0	T21235	SERVICE KIT FOR FORK & PAD		1	INCLUDES 8881826 & 8882321	
0	U8877720	SELECTOR ASSY. O/D		1		
1	8874835	SELECTOR SHAFT		1		
2	8876394	SELECTOR KEY		1		
3	8876395	INTERLOCK KEY		1		
4	8875503	FORK REVERSE		1		
5	8882620	FORK 1ST/2ND	8880805	1		
6	8882619	FORK 3RD/4TH	8875501	1		
7	X8870277	DOWEL		1		
8	8873691	SCREW		1	M10X23 HEX HD	
9	8874755	SELECTOR BLOCK		1		

Item	Current Part	Description	Replaced Part	Qty.	Notes	Kits/Assys Where Needed
10	8877718	SELECTOR OVERDRIVE		1		
11	8881826	FORK OVERDRIVE	8880960	1		T21235
12	8882321	OVERDIVE SHIFT PAD	8872043	2		T21235

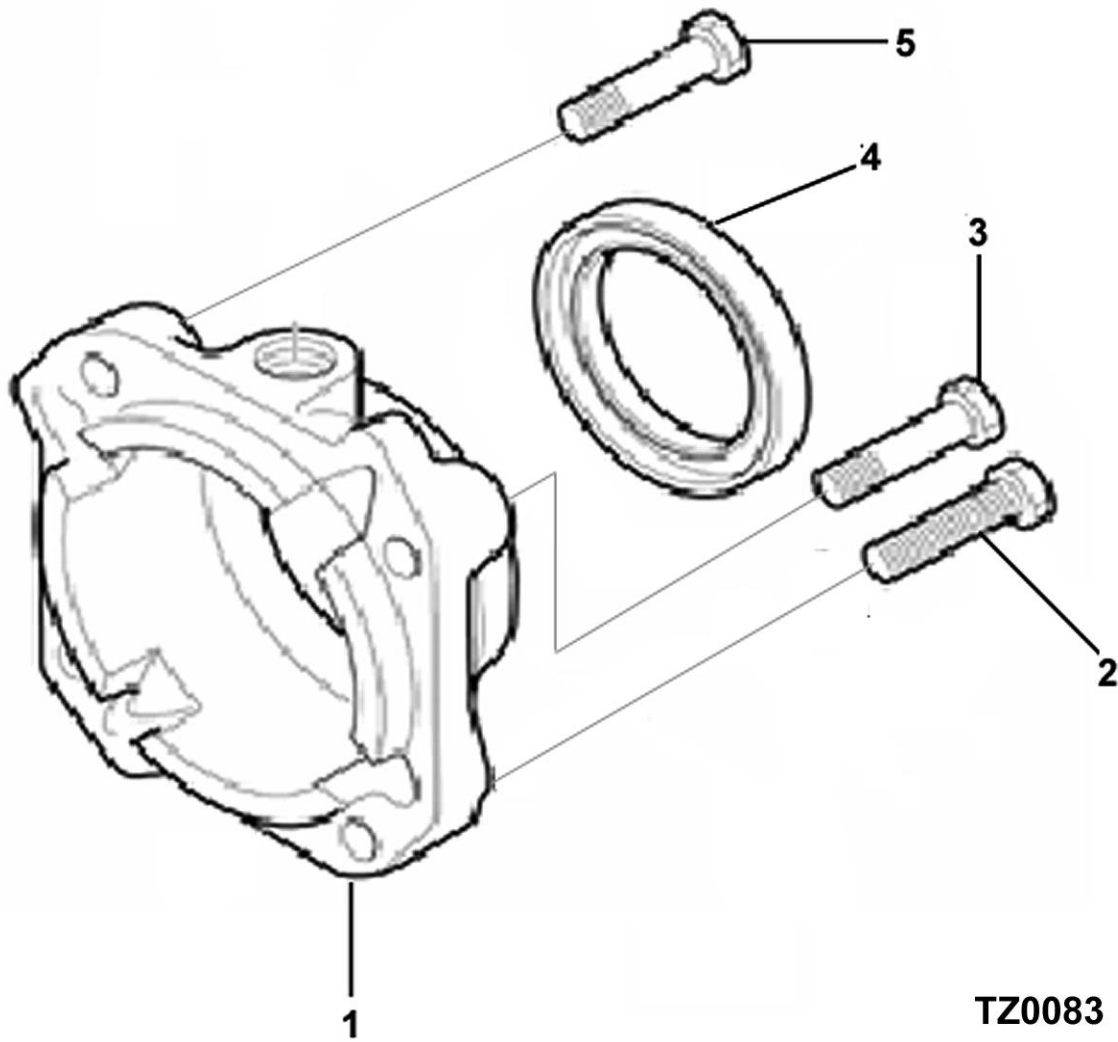

TZ0083

SPEEDO HOUSING

Item	Current Part	Description	Replaced Part	Qty.	Notes	Kits/Assys Where Needed
0	U8877435	SPEEDO HOUSING ASSY.		1		
1	8877757	SPEEDO HOUSING		1		
2	GMX-8-1093	BOLT		1	M10X45 HEX FLG HD	
3	GMX-8-1092	SCREW		1	M10 X 30 HEX FLG HD	
4	X8877434	OIL SEAL		1		
5	GMX-8-1091	SCREW		2	M10X30 HEX FLG HD	

Copyright Eaton Corporation, 2009.
Eaton hereby grants their customers,
vendors, or distributors permission to
freely copy, reproduce and/or distribute
this document in printed format. It may
be copied only in its entirety without
any changes or modifications. THIS
INFORMATION IS NOT INTENDED FOR
SALE OR RESALE, AND THIS NOTICE
MUST REMAIN ON ALL COPIES.

