

Eaton  
Illustrated  
Parts List

# Y08024

## Frontcase

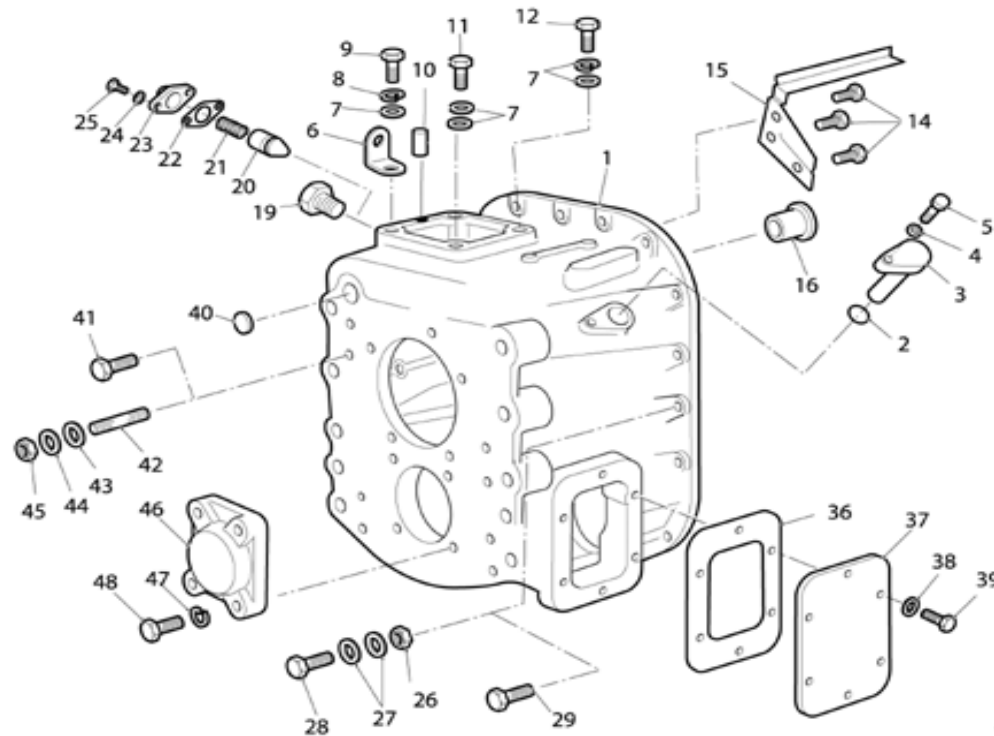

Part No:	English:	Deutsch:	Français:	Italiano:	Espanol:	Notes	QTY:	
00	U8882266	FRONT CASE ASSY	Vordergehäuse-Montage	Ensemble carter AV	scatola anteriore completa	Conjunto carcasa delantera	1	
01	8881855	FRONT CASE	Gehäuse	Carter	Corpo	Alojamiento	1	
06	D20815	LIFTING EYE	Hebering	Crochet de levage	staffa di sollevamento	Cáncamo de izar	1	
07	DX11245	WASHER	Scheibe	Rondelle	Rondella	Arrandela	M10 X 2MM	7
08	DMX-3-1001	SPRING WASHER	Federscheibe	Rondelle grower	Rondella di sicurezza	Arandela elásti	M10 X2.2MM	4
10	X8870542	DOWEL	Dübel, stift	(Douille)Goujon Perdu	Spina	Punto guia	8.0 DIA X 16	2
11	DMX-8-1066	BOLT	Schraubbolzen	Boulon	Vite	Perno	M10 X 40 HEX HD	2
12	DMX-8-1091	SCREW	Schraube	Vis	Vite	Tornillo	M10 X 35 HEX HD	4
14	X2014206	RIVET	Niet	Rivet	ribattino	remache	3.2 Dia x 8mm LONG	3
15	8877758	OIL TROUGH	Oel Leitrinne	Défecteur d'huile	Canal de aceite	passaggio dell'olio		1
16	8882415	BUSH	Buchse	Bague	Boccola	Casquillo		1
20	8873654	PLUNGER - NEUTRAL	Kolben – Neutral	Plongeur – Point Mort	pistoncino del folle	Vástago – Punto Muerto		1
21	8874897	SPRING COMPRESSION	Feder, verdichtungs-/kompressi	Ressort de compression	Compressione de Molla	Ballesta		1
22	8870590	GASKET	Dichtung	Joint	Guarnizione	Junta		1
23	D8870259	COVER - DETENT	Deckel – Sperre	Couvercle	Coperchio	Tapa		1
24	DMX-3-0801	SPRING WASHER	Federscheibe	Rondelle grower	Rondella di sicurezza	Arandela elásti	M8	2
25	DMX-8-0801	SCREW	Schraube	Vis	Vite	Tornillo	M8 X 14 HEX HD	2
26	DMX-9-1005	NUT	Mutter M10	Ecrou M10	Dado M10	Tuerca m10	M10	14

# Y08024

## Frontcase

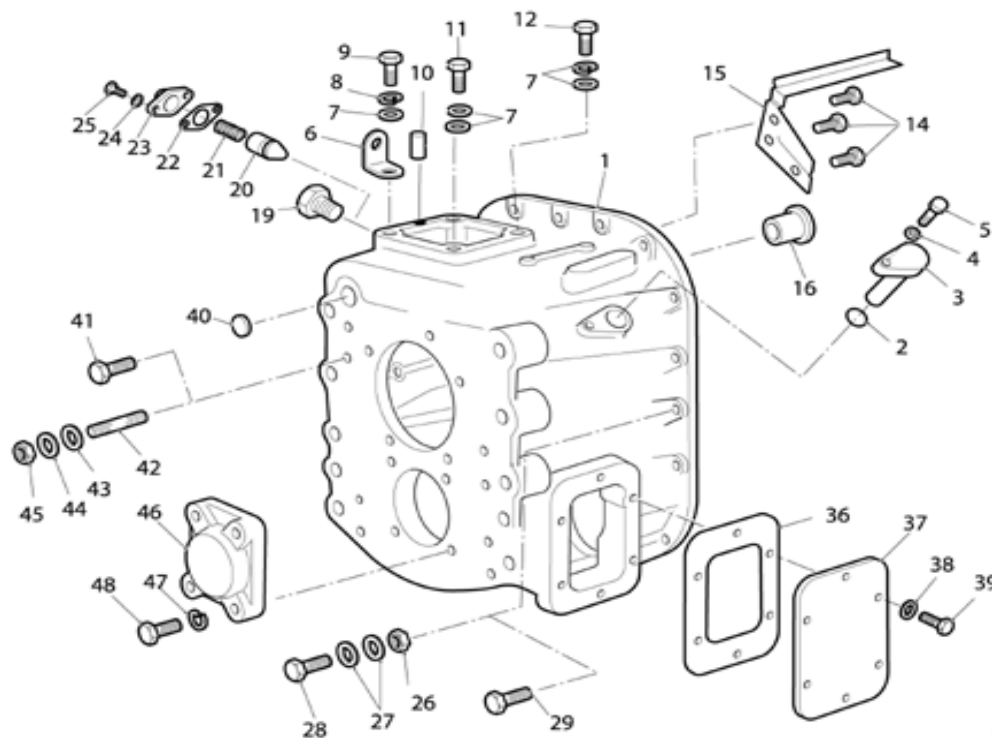

95R-01

Part No:	English:	Deutsch:	Français:	Italiano:	Espanol:	Notes	QTY:
28	DMX-8-1080	BOLT	Schraubbolzen	Boulon	Vite	M10 X 58	4
29	DMX-8-1079	BOLT	Schraubbolzen	Boulon	Vite	M10 x 40	4
33	D20815	LIFTING EYE	Hebering	Crochet de levage	staffa di sollevamento	Cáncamo de izar	1
37	8881616	PTO COVER	Deckel	Couvercle	Coperchio	Tapa	1
38	DMX-3-1001	SPRING WASHER	Federscheibe M10	Rondelle grower M10	Rondella di sicurezza M10	Arandela elásti M10	M10 X 2.2MM
39	DMX-8-1001	SCREW	Schraube	Vis	Vite	Tornillo	M10 X 20
40	8870278	PLUG	Stopfen	Bouchon	Tappo	Tapón	1
42	8873931	STUD	Stiftschraube	Goujon	Pridioniero	Espárrago	M12 x 75 long
46	8880554	BEARING COVER	Lagerdeckel	Couvercle de roulement	coperchio cuscinetto	Tapa cojinete	1
47	DMX-3-1201	SPRING WASHER	Federscheibe	Rondelle grower	Rondella di sicurezza	Arandela elásti	M12
48	DMX-8-1240	SCREW	Schraube	Vis	Vite	Tornillo	M12 X 25

# Y08024

## Intermediate Case

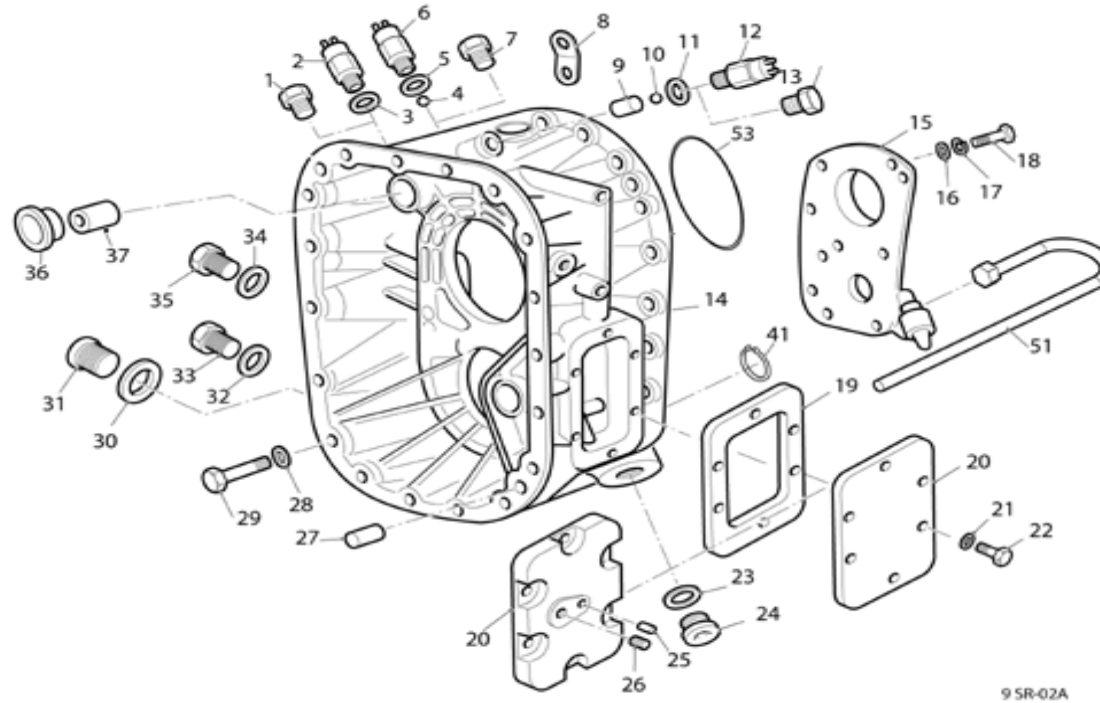

Part No:	English:	Deutsch:	Français:	Italiano:	Espanol:	Notes	QTY:
00	U8876645	INTERMEDIATE CASE ASS	Zwischengehäusemontage	Carter intermédiaire complet	scatola intermedia completa	Conjunto caja intermedia	1
02	8876416	REVERSE SWITCH	Schalter	Commutateur	Interruttore	Interruptor	1
04	X8870711	DETENT BALL	Rastkugel	Bille	Sfera	Bola	1
06	8876415	NEUTRAL SWITCH	Leerlaufschalter	Contacteur point mort	interruttore del folle	Conmutador de punto muerto	1
08	D8874026	LIFTING EYE	Hebering	Crochet de levage	staffa di sollevamento	Cáncamo de izar	1
09	8875267	INTERLOCK PIN	Riegel	Goupille/axe	Spina di consenso	Pasador de cierre	1
10	X8870711	DETENT BALL	Rastkugel	Bille	Sfera	Bola	1
11	X8880470	WASHER	Scheibe	Rondelle	Rondella	Arrandela	M16
13	DX8871502	PLUG	Stopfen	Bouchon	Tappo	Tapón	M16 X 1.5
14	8876644	INTERMEDIATE HOUSING	Zwischengehäusemontage	Carter intermédiaire complet	scatola intermedia completa	Conjunto caja intermedia	1
15	GU8875469	OIL PUMP ASSY	Ölpumpenmontage	Pompe à huile complète	pompa olio completa	Conjunto bomba de aceite	1
16	DX11245	WASHER	Scheibe	Rondelle	Rondella	Arrandela	M10 X 2MM
17	DMX-3-1001	SPRING WASHER	Federscheibe	Rondelle grower	Rondella di sicurezza	Arandela elásti	M10 X 2.2MM
18	DMX-8-1006	BOLT	Schraubbolzen	Boulon	Vite	Perno	M10 X 30 HEX HD
20	8881616	PTO COVER	Deckel	Couvercle	Coperchio	Tapa	1
21	DMX-3-1001	SPRING WASHER	Federscheibe	Rondelle grower	Rondella di sicurezza	Arandela elásti	M10 X 2.2MM
22	DMX-8-1001	SCREW	Schraube	Vis	Vite	Tornillo	M10 X 20
23	X8880469	WASHER	Scheibe	Rondelle	Rondella	Arrandela	1

# Y08024

## Intermediate Case

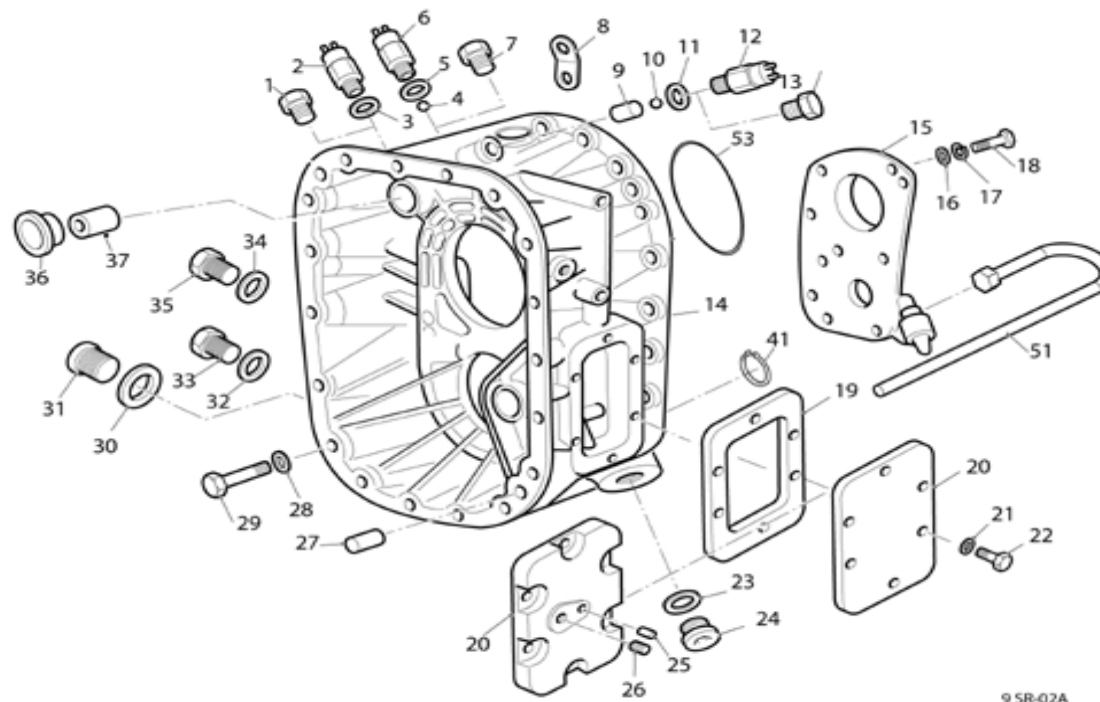

Part No:	English:	Deutsch:	Français:	Italiano:	Espanol:	Notes	QTY:
24	GX8876352	PLUG	Stopfen	Bouchon	Tappo	Tapón	1
24	DU8876353	OIL STRAINER ASSY	Ölsiebmontage	Crépine à huile complète	filtro olio completo	Conjunto filtro aceite	1
27	X8870543	DOWEL	Dübel, stift	(Douille)Goujon Perdu	Spina	Punto guía	2
30	X8880519	WASHER-FILL/DRAIN PLU	Unterlegscheibe – Füll/Ablassst	Rondelle de bouchon de remplis	rondella tappo scarico/riempim	Llenado lava -/ tapón de vaciad	1
31	GX8874942	PLUG-OIL FILLER	Stopfen – Ölfüller	Bouchon - remplissage d'huile	tappo di riempimento olio	Tapón – Aceite	1
36	8882415	BUSH	Buchse	Bague	Boccola	Casquillo	1
37	X8871377	BUSH	Buchse	Bague	Boccola	Casquillo	1
41	X8881424	CIRCLIP	Seegerring	Circlip	Anello elastico	Anillo elastico	1

# Y08024

## Input Shaft

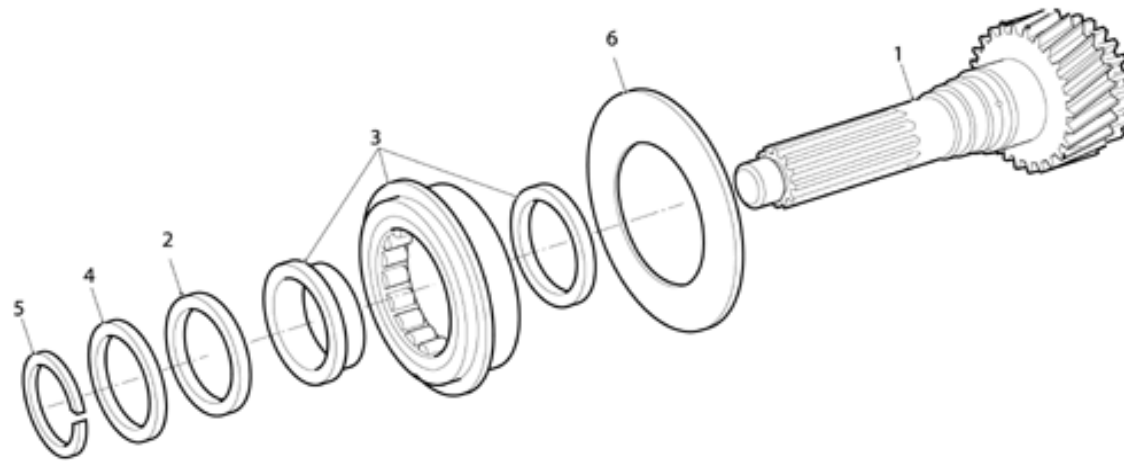

9 SR-03

Part No:	English:	Deutsch:	Français:	Italiano:	Espanol:	Notes	QTY:
00	U8880004	INPUT SHAFT ASSY	Eingangswellenmontage	Arbre d'entrée complet	albero entrata completo	Conjunto del eje de entrada	1
01	8877837	INPUT SHAFT	Eingangswelle	Arbre primaire	Albero entrata	Eje impulsor	1
03	X8872593	BEARING	Lager,	Roulement	Cuscinetto	Cojinete	1
04	8877692	SPACER	Distanzstück	Entretoise	Distanziale	Separador	3.10mm 1
04	U8877691	GRADED SPACER PACK	Packung abgestufte Zwischens	Paquet d'entretoises calibrées	pacco spessori graduati	Grupo separadores graduados	1
04	8877700	SPACER	Distanzstück	Entretoise	Distanziale	Separador	3.50mm 1
04	8877699	SPACER	Distanzstück	Entretoise	Distanziale	Separador	3.45mm 1
04	8877698	SPACER	Distanzstück	Entretoise	Distanziale	Separador	3.40mm 1
04	8877696	SPACER	Distanzstück	Entretoise	Distanziale	Separador	3.30mm 1
04	8877695	SPACER	Distanzstück	Entretoise	Distanziale	Separador	3.25mm 1
04	8877693	SPACER	Distanzstück	Entretoise	Distanziale	Separador	3.15mm 1
04	8877697	SPACER	Distanzstück	Entretoise	Distanziale	Separador	3.35mm 1
04	8877694	SPACER	Distanzstück	Entretoise	Distanziale	Separador	3.20mm 1
05	X8877706	CIRCLIP	Seegerring	Circlip	Anello elastico	Anillo elastico	1.95 1

# Y08024

## Frontcover Assy

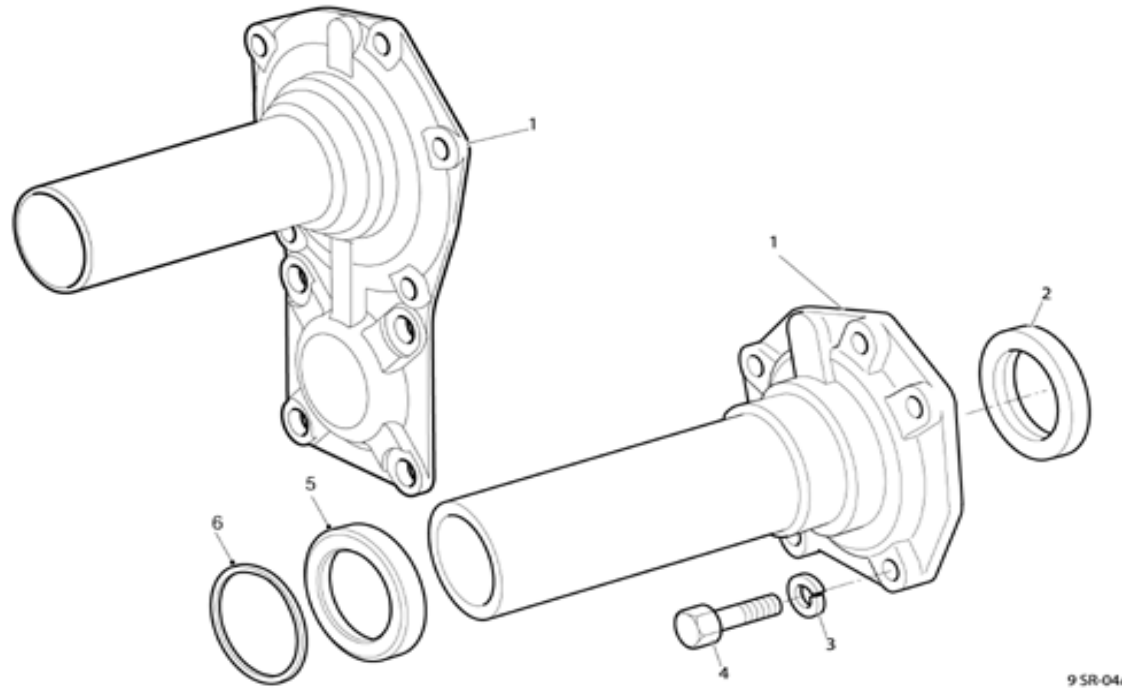

Part No:	English:	Deutsch:	Français:	Italiano:	Espanol:	Notes	QTY:
00 U8877544	FRONT COVER ASSY	Vorderdeckel-Montage	Ensemble carter AV	scatola anteriore completa	Conjunto carcasa delantera		1
01 8877543	FRONT COVER	Vorderdeckel	Couvercle antérieur	coperchio anteriore	Tapa delantera		1
02 X8870760	OIL SEAL	Öldichtung	Joint d'étanchéité d'huile	Anello tenuta cambio	Retén de aceite		1
03 DMX-3-1001	SPRING WASHER	Federscheibe	Rondelle grower	Rondella di sicurezza	Arandela elásti	M10 X 2.2MM	5
04 DMX-8-1089	SCREW	Schraube	Vis	Vite	Tornillo	M10 X 25	5

# Y08024

## Mainshaft

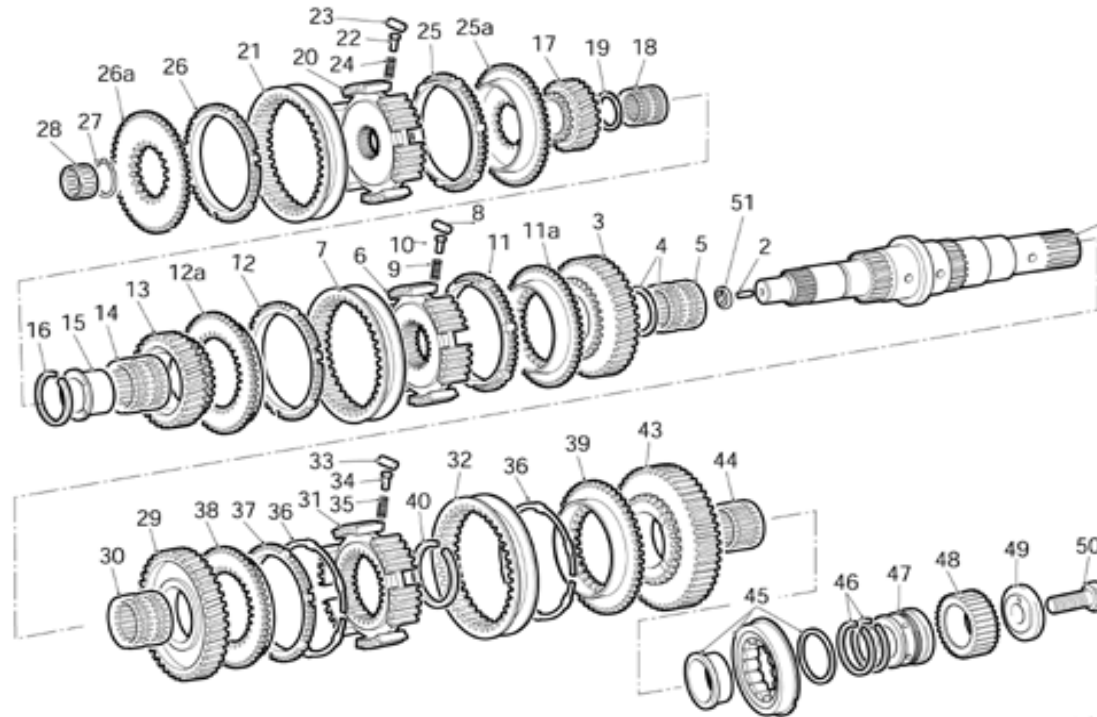

9 SR-05

Part No:	English:	Deutsch:	Français:	Italiano:	Espanol:	Notes	QTY:
00	U8880023	MAINSHAFT ASSY	Hauptwellenmontage	Arbre principal complet	albero primario completo	Conjunto del eje pral.	1
01	U8877167	MAINSHAFT SUB ASSY	Hauptwelle	Arbre principal	albero primario	Eje principal	1
02	X14851	SPIROL PIN	Spiralstift	Goupille Spirol	spina elastica	Pasador espiral	1
03	8876948	1ST GEAR	Zahnrad 1. Gang	Pigon de 1eme	Ingranaggio albero principale 1	Engranaje 1a	1
04	8872589	SPACER	Distanzstück	Entretoise	Distanziale	Separador	1
05	X8872233	NEEDLE ROLLER	Nadel	Aiguille	cuscinetto ad aghi	Cuello combust.	1
06	8875571	FIXED HUB	Festnabe	Moyeu fixe	mozzo fisso	Cubo fijo	1
07	8875377	SLIDING SLEEVE	Schiebemuffe	Anneau baladeur	Manicotto scorrevole	Casquillo deslizante	1
08	X8870356	ROLLER	Rolle	Rouleau	rullo	Rodillo	3
09	8870444	SPRING	Feder	Ressort	Molla	Ballesta	3
10	8870352	PLUNGER	Bolzen	Plongeur	Nottlino	Vastago	3
11	8877441	SYNCHRO RING	Synchronring	Anneau de synchro	Andello sincronizzatore	Anillo sincro.	1
11A	8877321	SYNCHRO FLANGE	SynchronFlansch	Bride de Synchro	Flangia sincronizzatore	Brida de sincronizacion	1
12	8877441	SYNCHRO RING	Synchronring	Anneau de synchro	Andello sincronizzatore	Anillo sincro.	1
12A	8877321	SYNCHRO FLANGE	SynchronFlansch	Bride de Synchro	Flangia sincronizzatore	Brida de sincronizacion	1
13	8876949	2ND GEAR	Zahnrad 2. Gang	Pigon de 2eme	ngranaggio albero principale 2	Engranaje 2a	1
14	X8872233	NEEDLE BEARING	Nadel	Aiguille	cuscinetto ad aghi	Cuello combust.	1
15	8875196	BEARING SLEEVE	Lagerbuchse	Manchon de roulement	pista del cuscinetto	Casquillo de cojinete	1



# Y08024

## Mainshaft

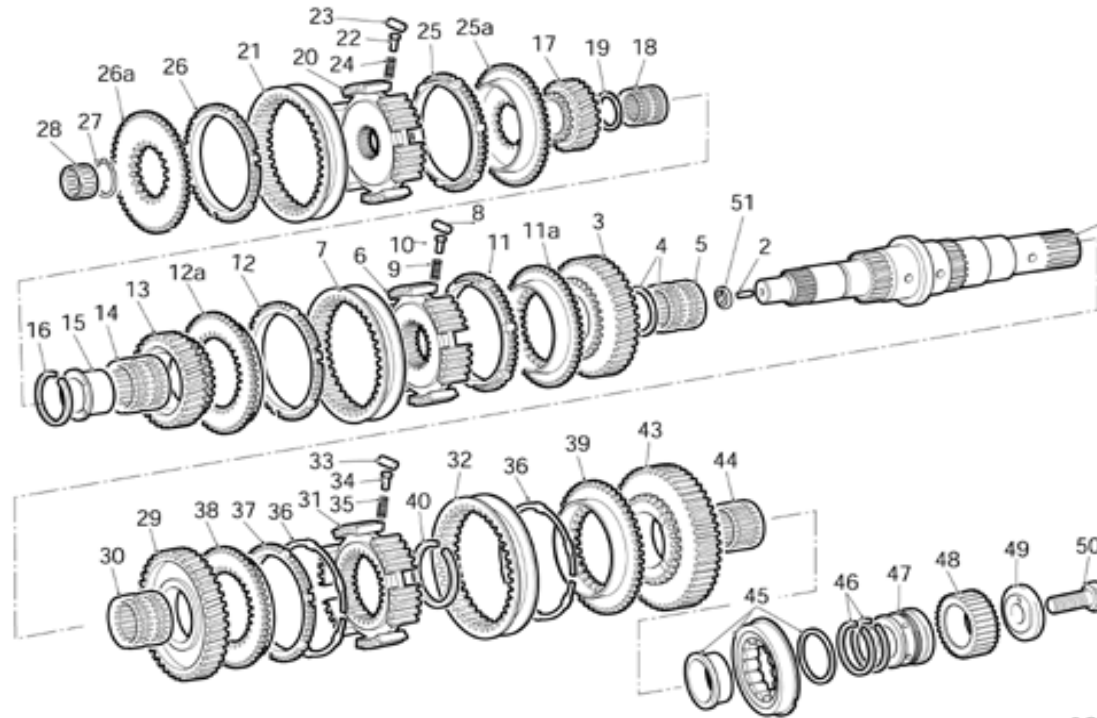

9 SR-05

Part No:	English:	Deutsch:	Français:	Italiano:	Espanol:	Notes	QTY:
16	U8882558	CIRCLIP PACK	Packung Sicherungsringe	Paquet de circlips	gruppo anelli elastici	Grupo resortes circulares	1
17	8880740	3RD GEAR	Zahnrad 3. Gang	Pigon de 3eme	Ingranaggio albero principale 3	Engranaje 3a	1
18	X8870180	NEEDLE BEARING	Nadel	Aiguille	cuscinetto ad aghi	Cuello combust.	NEEDLE ROLLER BRG 1
19	8872588	SPACER	Distanzstück	Entretoise	Distanziale	Separador	1
20	8875554	FIXED HUB	Festnabe	Moyeu fixe	mozzo fisso	Cubo fijo	1
21	8875377	SLIDING SLEEVE	Schiebemuffe	Anneau baladeur	Manicotto scorrevole	Casquillo deslizante	1
22	8870352	PLUNGER	Kolben	Plongeur	pistoncino	Vástago	3
23	X8870356	ROLLER	Rolle	Rouleau	rullo	Rodillo	3
24	8870444	SPRING	Feder	Ressort	Molla	Ballesta	3
25	8877441	SYNCHRO RING	Synchronring	Anneau de synchro	Andello sincronizzatore	Anillo sincro.	1
25A	8877321	SYNCHRO FLANGE	SynchronFlansch	Bride de Synchro	flangia del sincronizzatore	Brida sincronizadora	1
26	8877441	SYNCHRO RING	Synchronring	Anneau de synchro	Andello sincronizzatore	Anillo sincro.	1
26A	8877321	SYNCHRO FLANGE	SynchronFlansch	Bride de Synchro	flangia del sincronizzatore	Brida sincronizadora	1
27	X8870372	CIRCLIP	Seegerring	Circlip	Anello elastico	Anillo elastico	DIA 40 X 2.00MM 1
27	U8877531	CIRCLIP PACK	Packung Sicherungsringe	Paquet de circlips	gruppo anelli elastici	Grupo resortes circulares	1
27	X8870370	CIRCLIP	Seegerring	Circlip	Anello elastico	Anillo elastico	DIA 40 X 2.12MM 1
27	X8870371	CIRCLIP	Seegerring	Circlip	Anello elastico	Anillo elastico	DIA 40 X 2.07MM 1
28	X8870305	NEEDLE BEARING	Nadel	Aiguille	cuscinetto ad aghi	Cuello combust.	NEEDLE ROLLER BRG 1

# Y08024

## Mainshaft

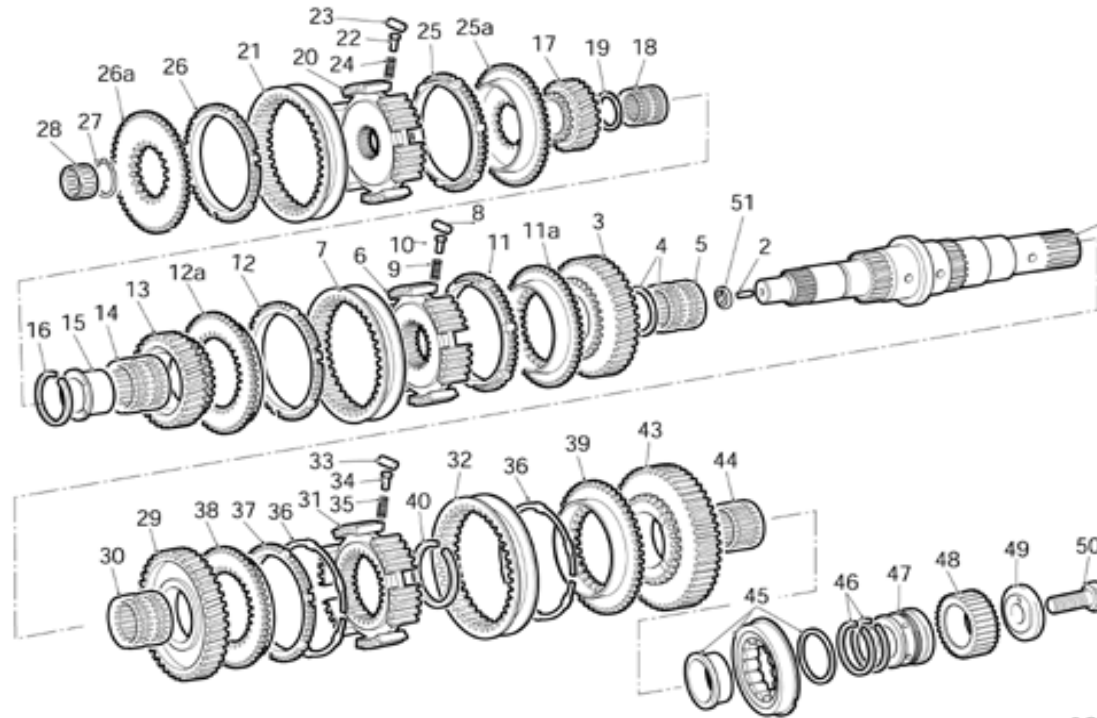

9 SR-05

Part No:	English:	Deutsch:	Français:	Italiano:	Espanol:	Notes	QTY:
29	8876477	CRAWLER GEAR	riechgang	Pignon rampant	ingranaggio del primino	Engranaje marcha mínima	1
30	X8872233	NEEDLE BEARING	Nadel	Aiguille	cuscinetto ad aghi	Cuello combust.	NEEDLE ROLLER BRG 1
31	8875604	FIXED HUB	Festnabe	Moyeu fixe	mozzo fisso	Cubo fijo	1
32	8875376	SLIDING SLEEVE	Schiebemuffe	Anneau baladeur	Manicotto scorrevole	Casquillo deslizante	1
33	X8870356	ROLLER	Rolle	Rouleau	rullo	Rodillo	3
34	8870352	PLUNGER	Kolben	Plongeur	pistoncino	Vastago	3
35	8870444	SPRING	Feder	Ressort	Molla	Ballesta	3
36	X8873994	CIRCLIP	Seegerring	Circlip	Anello elastico	Anillo elastico	2
38	8880059	SYNCHRO FLANGE	Synchronflansch	Bride de synchro	flangia del sincronizzatore	Brida sincronizadora	1
39	8870415	SYNCHRO FLANGE -REVE	Synschronflansch - Rückwärts	Bride de synchro-Marche AR	retromarcia	Brida sincron. - marcha atrás	1
40	U8877532	CIRCLIP PACK	Packung Sicherungsringe	Paquet de circlips	gruppo anelli elastici	Grupo resortes circulares	1
40	X8870379	CIRCLIP	Seegerring 2.05MM	Circlip 2.05MM	Anello elastico 2.05MM	Anillo elastico	2.05MM 1
40	X8870378	CIRCLIP	Seegerring 2.10MM	Circlip 2.10MM	Anello elastico 2.10MM	Anillo elastico	2.10MM 1
40	X8870380	CIRCLIP	Seegerring 2.00MM	Circlip 2.00MM	Anello elastico 2.00MM	Anillo elastico	2.00MM 1
43	8876478	REVERSE GEAR	Rückwärtsgang	Pignon de marche AR	ingranaggio retromarcia	Piñón marcha atrás	1
44	X8870178	NEEDLE BEARING	Nadel	Aiguille	cuscinetto ad aghi	Cuello combust.	NEEDLE ROLLER BRG 1
45	X8877164	REAR BEARING	Lagerrückseite	Roulement AR	cuscinetto posteriore	Cojinete trasero	1
46	X8875532	SEALING RING	Dichtungsring	Anneau d'étanchéité	anello di tenuta	Arandela obturadora	2

Y08024

Mainshaft

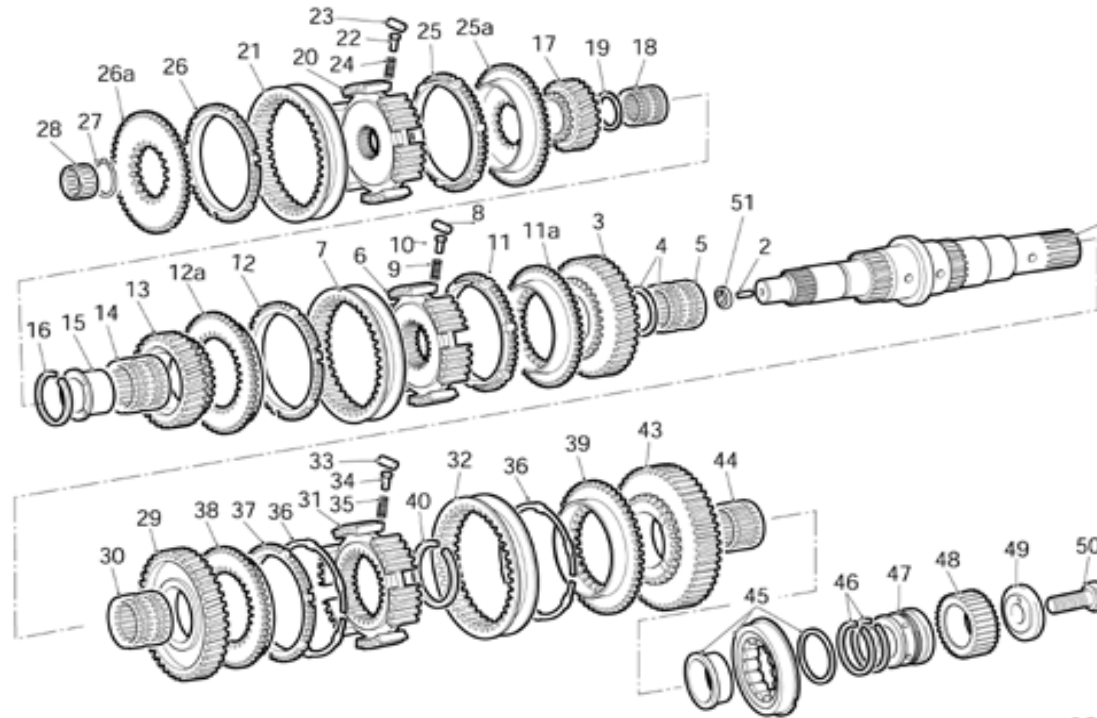

9 SR-05

Part No:	English:	Deutsch:	Français:	Italiano:	Espanol:	Notes	QTY:
47	8874921	OIL MUFF	Ölmanschette	Manchon d'huile	OIL MUFF	Muffa aceite	1
48	8875585	SUN GEAR	Sonnenrad	Satellite	ingranaggio solare	Engranaje planetario	1
49	8880594	RETAINER	Halter	arrêtoir	Tassello	Retenedor	1
50	X8870699	SCREW	Schraube	Vis	Vite	Tornillo	1

# Y08024

## Countershaft

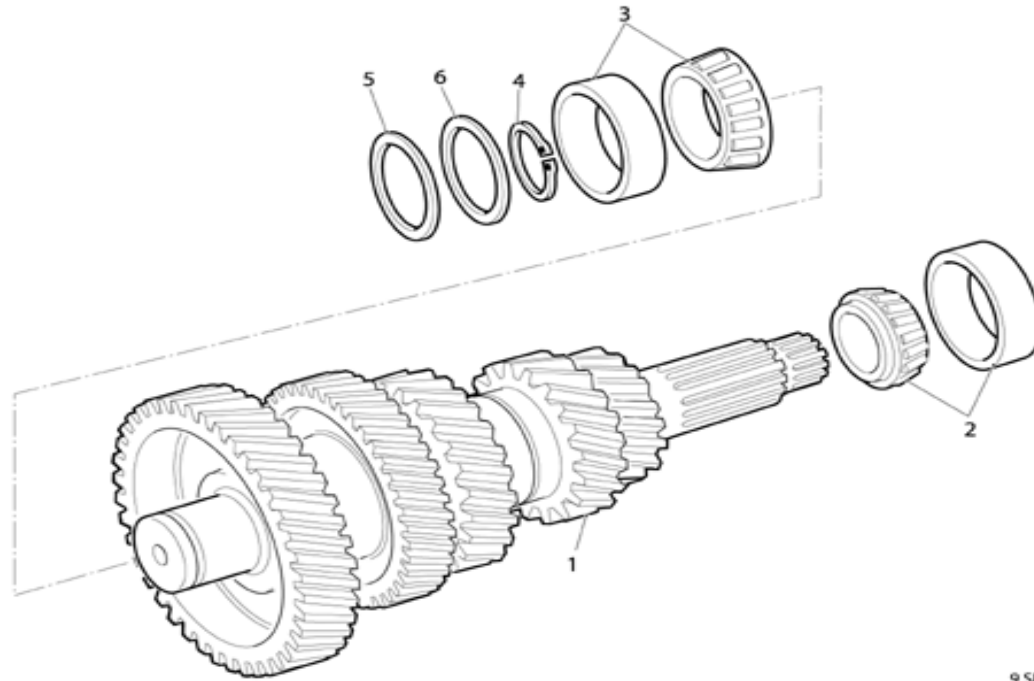

9 5R-06

Part No:	English:	Deutsch:	Français:	Italiano:	Espanol:	Notes	QTY:
01	U8880745	LAYSHAFT ASSY	Zwischenwelle	Arbre secondaire complet	albero secundario	Conjunto del eje secundario de	1
02	X8875587	BEARING ASSY	Lagermontage	Roulement complet	cuscinetto completo	Conjunto cojinete	1
03	X8875587	BEARING ASSY	Lagermontage	Roulement complet	cuscinetto completo	Conjunto cojinete	1
04	X8871536	CIRCLIP	Seegerring	Circlip	Anello elastico	Anillo elastico	1.97MM
04	X8870372	CIRCLIP	Seegerring	Circlip	Anello elastico	Anillo elastico	2.00MM
04	X8871539	CIRCLIP	Seegerring	Circlip	Anello elastico	Anillo elastico	1.82MM
04	X8871540	CIRCLIP	Seegerring	Circlip	Anello elastico	Anillo elastico	1.77MM
04	X8871538	CIRCLIP	Seegerring	Circlip	Anello elastico	Anillo elastico	1.87MM
04	X8870371	CIRCLIP	Seegerring	Circlip	Anello elastico	Anillo elastico	2.07MM
04	X8870370	CIRCLIP	Seegerring	Circlip	Anello elastico	Anillo elastico	2.12MM
04	X8871537	CIRCLIP	Seegerring	Circlip	Anello elastico	Anillo elastico	1.92MM
04	U8877534	CIRCLIP PACK	Packung Sicherungsringe	Paquet de circlips	gruppo anelli elastici	Grupo resortes circulares	1
05	8875879	SPACER	Distanzstück	Entretoise	Distanziale	Separador	2MM
06	F88894	SHIM	Ausgleichsscheibe	Cale	Distanziale	Relleno	.020
06	F88891	SHIM	Ausgleichsscheibe	Cale	Distanziale	Relleno	.002
06	F88893	SHIM	Ausgleichsscheibe	Cale	Distanziale	Relleno	.010
06	F88892	SHIM	Ausgleichsscheibe	Cale	Distanziale	Relleno	.025
06	U8877535	SHIM Kit	Ausgl.schei.kit	Kit cale	Distanziale	Kit de relleno	1

# Y08024

## Reverse Idler

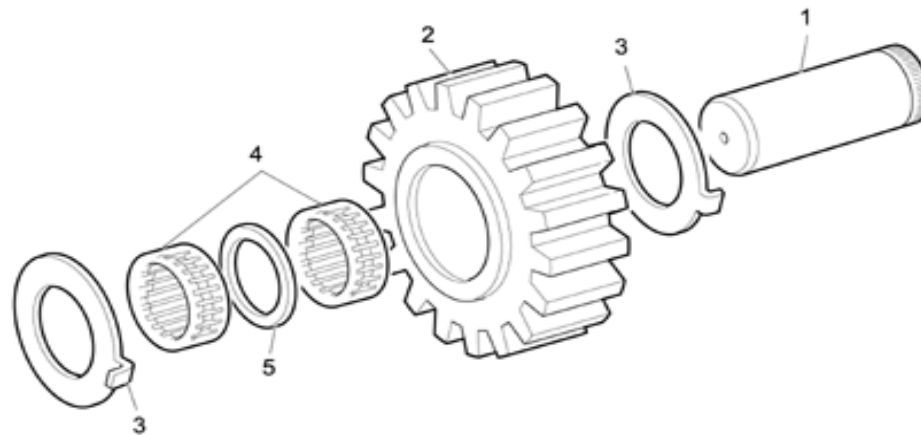

9 SR-07

Part No:	English:	Deutsch:	Français:	Italiano:	Espanol:	Notes	QTY:
01 8880069	REVERSE IDLER SHAFT	Rückwärts Welle	Axe de pignon de renvoi de mar	Albero, Ingranaggio rinvio RM	Eje intermedio de MA		1
02 8876457	REVERSE IDLER GEAR	Rückwärts-Umkehrad	Pignon de renvoi de marche AR	ruota oziosa retromarcia	Intermedio de marcha atrás		1
03 8870343	THRUST WASHER	Schub-Unterlegscheibe	Rondelle de poussée	rondella di battuta	Arandela de empuje		2
04 X8872478	NEEDLE ROLLER	Nadel	Aiguille	cuscinetto ad aghi	Cuello combust.		2
05 8872479	SPACER	Distanzstück	Entretoise	Distanziale	Separador		1

# Y08024

## Selector Assy

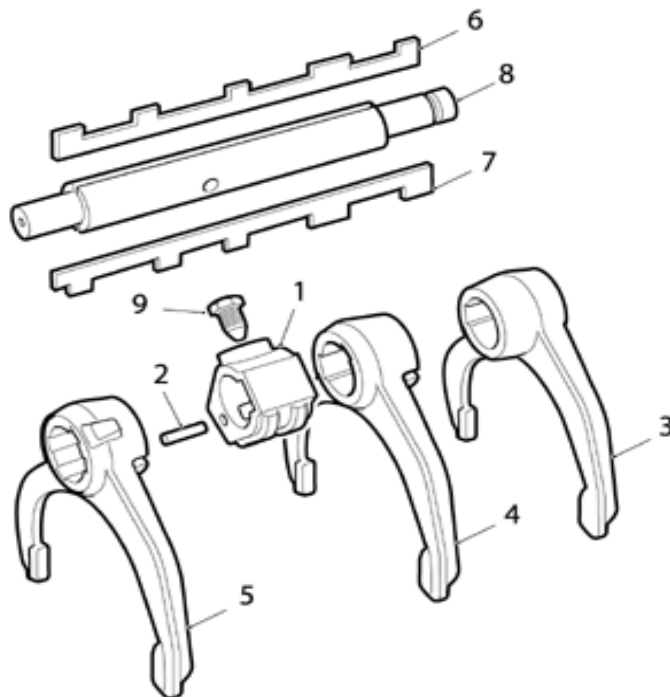

9 SR-08

Part No:	English:	Deutsch:	Français:	Italiano:	Espanol:	Notes	QTY:	
00	U8880546	SELECTOR ASSY	Gangwählermontage	Sélecteur complet	selettore completo	Conjunto selector		1
01	8874754	SELECTOR BLOCK	Schaltblock	Bloc sélecteur	selettore completo	Bloque selector		1
02	X8870277	DOWEL	Stift	Goupille	Spina	Pasador		1
03	8875499	SHIFT FORK	Gangschaltgabel	Fourchette commande de vit.	Forca	Horquilla		1
04	8880760	SHIFT FORK	Gangschaltgabel	Fourchette commande de vit.	Forca	Horquilla		1
05	8875497	SHIFT FORK	Gangschaltgabel	Fourchette commande de vit.	Forca	Horquilla		1
06	8872328	SELECTOR KEY	Schalklinke	Reglette de selection	Chiavetta selettore	Llava selectora		1
07	8880759	INTERLOCK KEY	Sperre-Schlüssel	Clavette de verrouillage	CHIAVETTA DI CONSENSO I	Llave interbloqueo		1
08	8875829	SELECTOR SHAFT	Schaltwelle	Arbre sélecteur	albero del selettore	Horqu. select.		1
09	8873691	LOCATION SCREW	Zentrierschraube	Vis de localisation	vite di centraggio	Tornillo de fijación	M10 X 23 HEX HD	1

Y08024

LRC

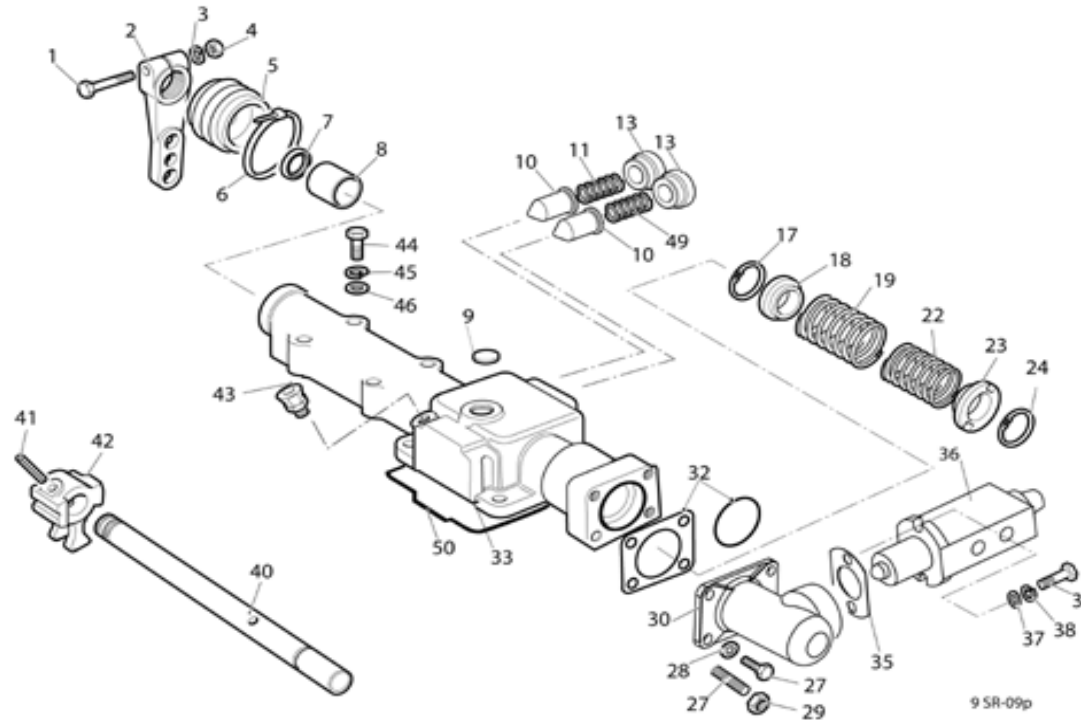

Part No:	English:	Deutsch:	Français:	Italiano:	Espanol:	Notes	QTY:
00	U8881270	LRC ASSY	Fernbedienungsmontage	Commande à distance complète	GRUPPO COMANDI ESTERN	Conjunto del control remoto	
01	DMX-8-1007	BOLT	Schraubbolzen	Boulon	Vite	Perno	M10 X 50
02	D8876842	OUTER LEVER	Hebel	Levier	Leva	Palanca	
04	DMX-9-1005	NUT	Mutter	Ecrou	Dado	Tuerca	
05	X8875259	BOOT ACCORDIAN	Faltenbalg	Gaîne protection accordéon	soffietto di protezione	Fuelle protector	
07	X8881481	OIL SEAL	Öldichtung	Joint d'étanchéité d'huile	Anello tenuta cambio	Retén de aceite	
09	DX8871486	PLUG-EXPANSION	Stopfen - Vergrößerung	Bouchon à expansion	tappo ad espansione	Tapón - Dilatador	
10	8880986	DETENT PLUNGER	Kolben - Sperre	Plongeur - verrouillage	pistoncino di ritegno	Vástago - Detención	
11	8881592	SPRING COMPRESSION	Feder, verdichtungs-/kompressi	Ressort de compression	Compressione de Molla	Ballesta	
13	X8880301	PLUG	Stopfen	Bouchon	Tappo	Tapón	
17	X8874450	CIRCLIP	Seegerring	Circlip	Anello elastico	Anillo elastico	
18	8876566	SPRING RETAINER	Feder-Halter - Verstärker	Retenue de ressort - renforc.	ritegno molla-di spinta	Sujetaresorte - Reforzador	
19	8873735	SPRING COMPRESSION	Feder, verdichtungs-/kompressi	Ressort de compression	Compressione de Molla	Ballesta	
22	8876344	SPRING COMPRESSION	Feder, verdichtungs-/kompressi	Ressort de compression	Compressione de Molla	Ballesta	
23	8876567	SPRING RETAINER	Feder-Halter	Retenue de ressort	ritegno molla	Sujetaresorte	
24	X8874450	CIRCLIP	Seegerring	Circlip	Anello elastico	Anillo elastico	
27	2772071	STUD	Stiftschraube	Goujon	Pridioniero	Espárrago	M12 x 75MM
29	DMX-9-0803	NUT	Mutter	Ecrou	Dado	Tuerca	NUT M8 HEX FLG

Y08024

LRC

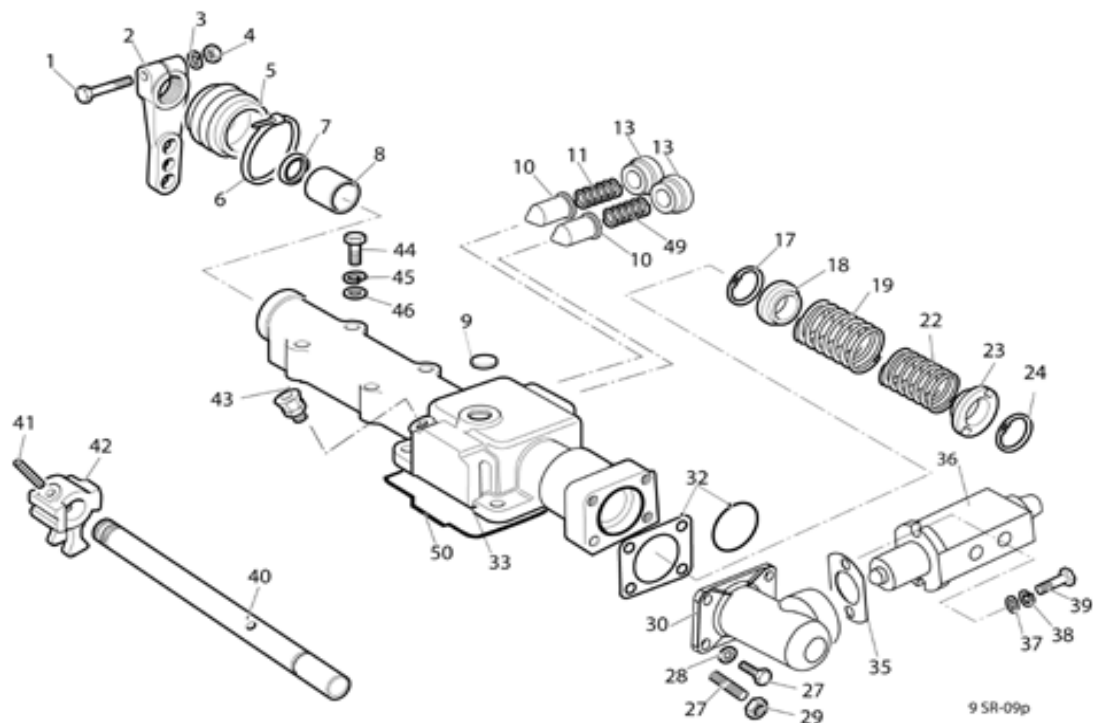

Part No:	English:	Deutsch:	Français:	Italiano:	Espanol:	Notes	QTY:
30	8880467	CONTROL VALVE HOUSIN	Carter de valve	scatola da valvola	Caja da válvula		1
32	X8880639	'O' RING	Ring -O	Joint torique	Guarnizione toroidale	Tuberías nylon	1
33	U8880718	LRC SUB ASSY					1
35	F91353	JOINT	Verbindungsteil	Joint d'étanchéité	giunto	Junta	1
36	F96387	RANGE VALVE	Bereichsventil	Valve de gamme	valvola cambio gamma	Válvula cambio gama	1
37	DMX-10-0601	WASHER	Scheibe	Rondelle	Rondella	Arrandela	2
38	DMX-3-0602	WASHER	Scheibe	Rondelle	Rondella	Arrandela	2
39	DMX-8-0629	SCREW	Schraube	Vis	Vite	Tornillo	M6 X 20MM
40	8880294	CROSS SHAFT	Schaltung	Levier rapport	Tirante regola	Varilla regulad.	1
41	X8871378	DOWEL	Dübel, stift	(Douille)Goujon Perdu	Spina	Punto guia	1
42	8880298	INNER STRIKING LEVER	Innerer Schlaghebel	Embrayeur intérieur	leva di selezione	Palanca de embrague	1
43	X2014210	BREATHER	Entlüfter	Reniflard	Sfiatatoi	Respiradero	1
44	GMX-8-1005	BOLT	Schraubbolzen	Boulon	Vite	Perno	M10 X 55
45	DMX-3-1001	SPRING WASHER	Federscheibe	Rondelle grower	Rondella di sicurezza	Arandela elásti	M10 X 2.2MM
46	DMX-3-1001	SPRING WASHER	Federscheibe	Rondelle grower	Rondella di sicurezza	Arandela elásti	M10 X 2.2MM
50	8880638	SEAL - LRC	Dichtung	Joint	Guarnizione	Sello	1



# Y08024

## Planet Carrier

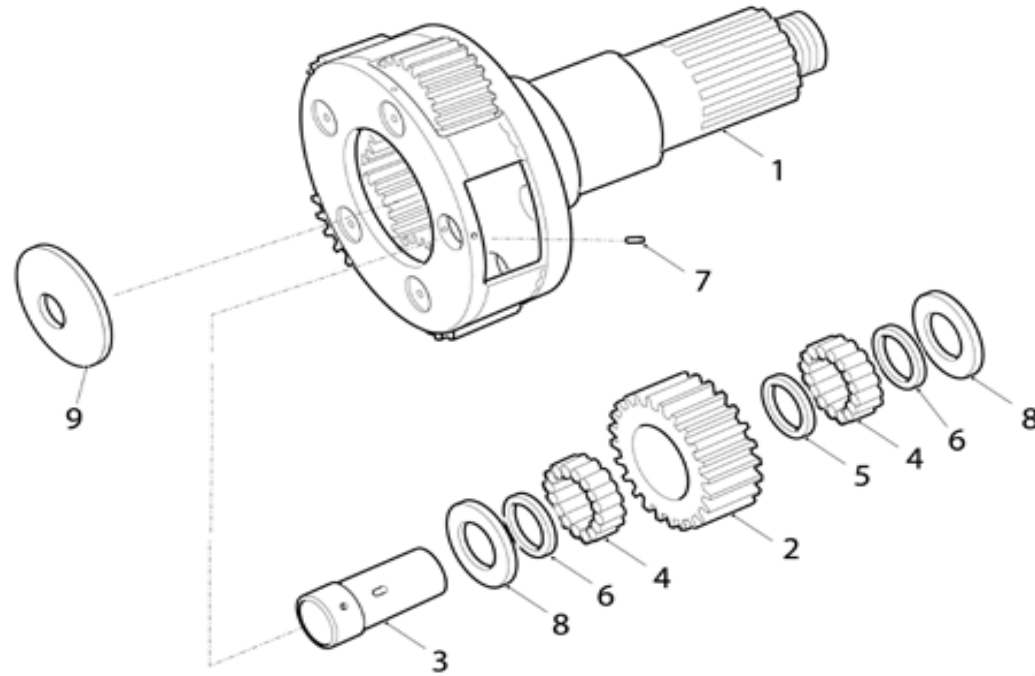

9 5R-10A

Part No:	English:	Deutsch:	Français:	Italiano:	Espanol:	Notes	QTY:	
01	U8882490	OUTPUT SHAFT ASSY	Ausgangswellenmontage	Arbre de sortie complet	albero uscita completo	Conjunto del eje de salida		1
02	8875586	PLANET GEAR	Planetenrad	Pignon planétaire	ingranaggio satellite	Engranaje planetario		5
03	8872682	PLANET SPINDLE	Planetenspindel	Fuseau de planétaire	perno del satellite	Eje satélite		5
04	X8872678	ROLLER	Rolle	Rouleau	rullo	Rodillo		180
05	8872741	SPACER	Distanzstück	Entretoise	Distanziale	Separador		5
06	8874827	THRUST WASHER	Schub-Unterlegscheibe	Rondelle de poussée	rondella di battuta	Arandela de empuje	0.4MM	10
07	MX-11-0601	SCREW	Schraube	Vis	Vite	Tornillo	M6 X 10	5
08	8876893	THRUST WASHER	Schub-Unterlegscheibe	Rondelle de poussée	rondella di battuta	Arandela de empuje	1.5MM	10

# Y08024

## Rear Housing

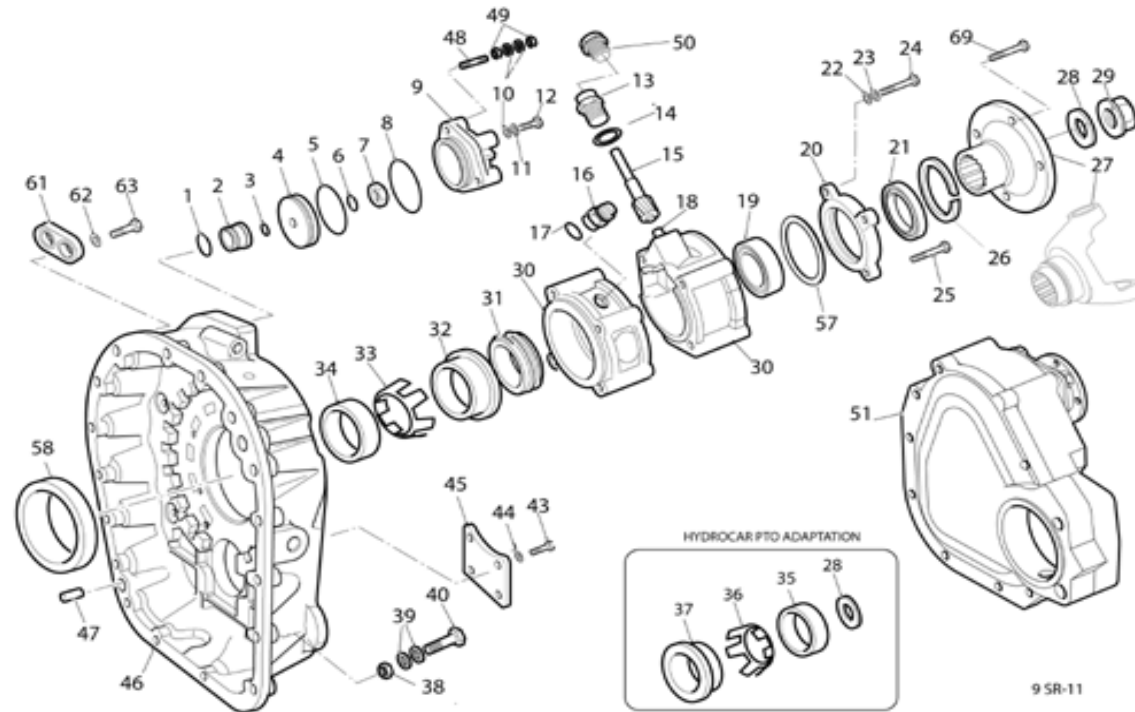

Part No:	English:	Deutsch:	Français:	Italiano:	Espanol:	Notes	QTY:
01	X8875292	'O' RING	Ring -O	Joint torique	Guarnizione toroidale	Tuberías nylon	1
02	8875293	BUSH	Buchse	Bague	Boccola	Casquillo	1
03	X8871258	'O' RING	Ring -O	Joint torique	Guarnizione toroidale	Tuberías nylon	1
04	8875179	PISTON RANGE CYLINDER	Kolbenbereichszylinder	Cylindre de piston de gamme	pistone cambio gamma	Pistón cilindro gama	1
05	14344	'O' RING	Ring -O	Joint torique	Guarnizione toroidale	Tuberías nylon	1
06	14345	'O' RING	Ring -O	Joint torique	Guarnizione toroidale	Tuberías nylon	1
07	GMX-9-1602	NUT	Mutter	Ecrou	Dado	Tuerca	M16 X 2
08	X8873008	'O' RING	Ring -O	Joint torique	Guarnizione toroidale	Tuberías nylon	1
09	8875430	CYLINDER - RANGE	Zylinder - Bereich	Cylindre de gamme	cilindro gamma	Cilindro - Gama	1
10	DX11245	WASHER	Scheibe	Rondelle	Rondella	Arrandela	M10 X 2MM
11	DMX-3-1001	SPRING WASHER	Federscheibe	Rondelle grower	Rondella di sicurezza	Arandela elásti	M10 X 2.2MM
12	DMX-8-1094	BOLT	Schraubbolzen	Boulon	Vite	Perno	M10 X 60 HEX HD
13	X8877476	SPEEDO PICKUP	Tachogeber	Pick-up - tachymètre	trasmettitore tachimetro	Sensor del velocímetro	1
19	X8872721	BEARING	Lager	Roulement	Cuscinetto	Cojinete	1
20	8871992	REAR COVER OIL SEAL	Rückdeckel	Couvercle AR	coperchio posteriore	Tapa trasera	1
21	X8872722	OIL SEAL	Öldichtung	Joint d'étanchéité d'huile	Anello tenuta cambio	Retén de aceite	1
22	DX11245	WASHER	Scheibe	Rondelle	Rondella	Arrandela	M10 X 2MM
23	DMX-3-1001	SPRING WASHER	Federscheibe	Rondelle grower	Rondella di sicurezza	Arandela elásti	M10 X 2.2MM

# Y08024

## Rear Housing

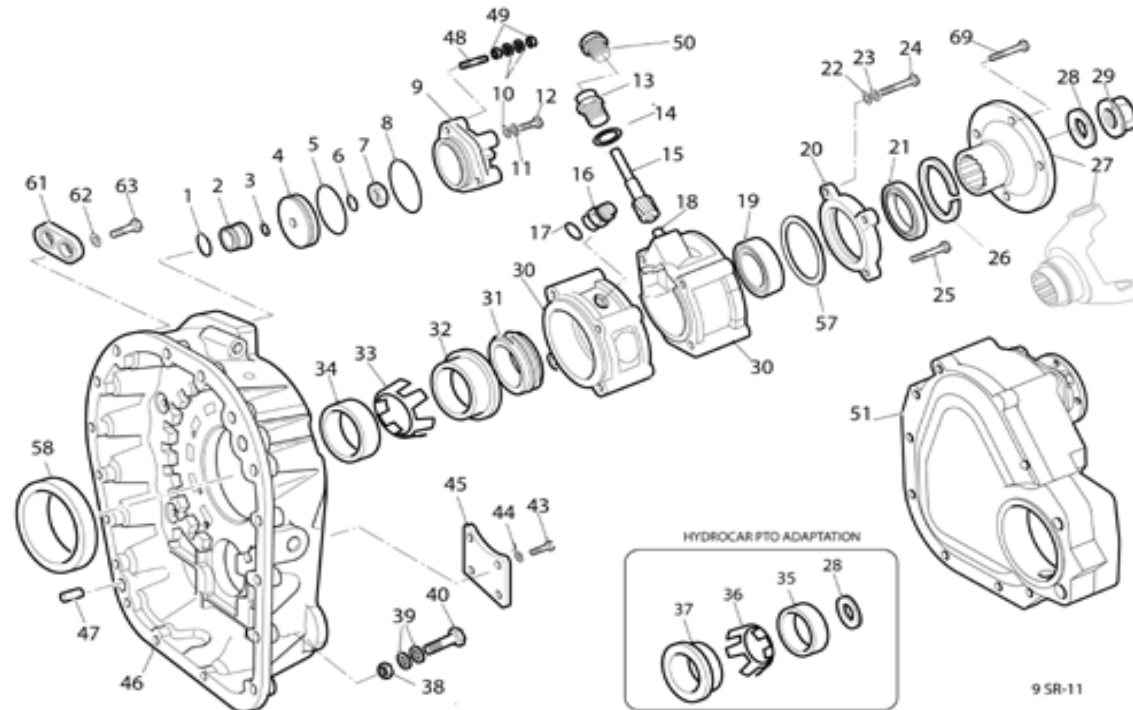

Part No:	English:	Deutsch:	Français:	Italiano:	Espanol:	Notes	QTY:
24	DMX-8-1095	BOLT	Schraubbolzen	Boulon	Vite	M10 X 100 HEX	3
25	DMX-8-1096	SCREW	Schraube	Vis	Vite	M10 X 100MM	1
27	D8877079	COUPLING FLANGE	Anschlußflansch	Bride de Sortie	flangia di uscita	Brida de acoplamiento	1
28	8877047	SPACER	Distanzstück	Entretoise	Distanziale	Separador	1
29	X8870553	NUT	Mutter	Ecrou	Dado	Tuerca M39	1
30	8874013	REAR COVER - ELEC. SPE	Rückdeckel – elektr. Tacho	Couvercle AR - Tachym. élec.	coperchio tachimetro elettronico	Tapa trasera del velocímetro el	1
31	8882427	SPEEDO DRIVE GEAR	Zahnrad	Zahnrad	Ingranaggio	Engranaje	1
38	DMX-9-1005	NUT	Mutter	Ecrou	Dado	Tuerca M10	17
40	DMX-8-1080	BOLT	Schraubbolzen	Boulon	Vite	M10 X 58MM	17
43	DMX-8-1240	SCREW	Schraube	Vis	Vite	M12 X 25MM	4
44	DMX-3-1201	SPRING WASHER	Federscheibe	Rondelle grower	Rondella di sicurezza	Arandela elásti M12	4
45	D8873917	COVER - LAYSHAFT REAR	Deckel – Zwischenwelle	Couvercle - arbre intermédiaire	Coperchio	Tapa - Eje secundario del cam	1
46	8874367	REAR CASE	Hinteres Gehäuse	Carter AV	Scatola posteriore	Carcasa trasera	1
47	X8870543	DOWEL	Dübel, stift	(Douille)Goujon Perdu	Spina	Punto guía	2

# Y08024

## Range Section

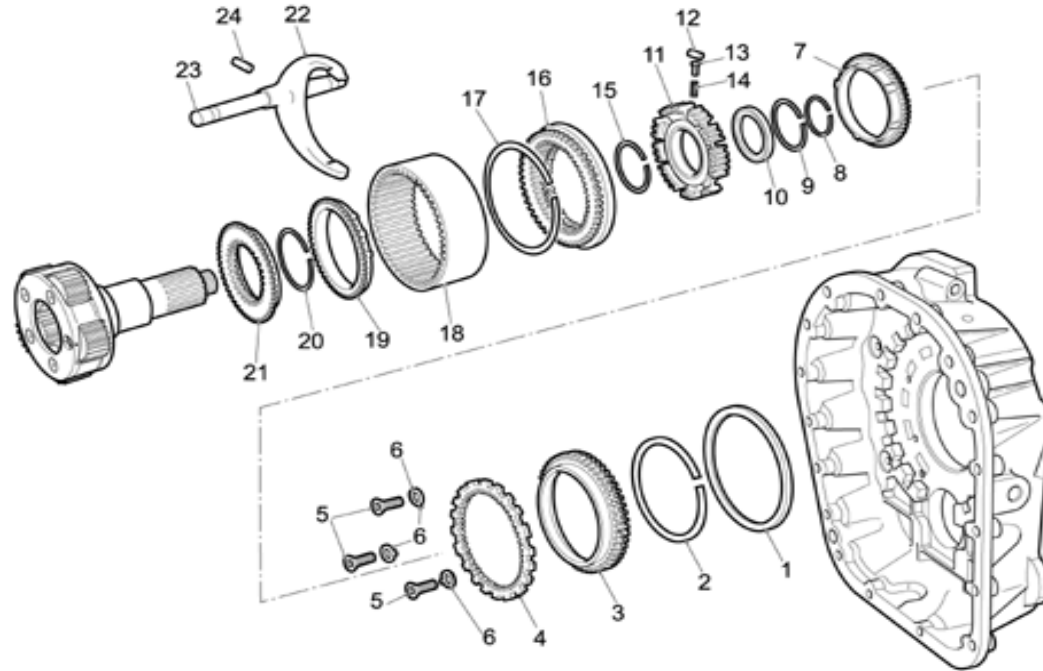

9 SR-12

Part No:	English:	Deutsch:	Français:	Italiano:	Espanol:	Notes	QTY:
00	U8877170	REAR HOUSING ASSY	Nachschaltgehäuseruppengenh	Carter Arrier assemble	Complessivo scatola posteriore	Conjunto tapa trasera	1
01	8870808	SPACER	Distanzstück	Entretoise	Distanziale	Separador	5.5 THICK
02	X8873993	CIRCLIP -	Seegerring	Circlip	Anello elastico	Anillo elastico	2.5 THICK
03	8877322	SYNCHRO FLANGE	Synchronflansch	Bride de Synchro	Flangia sincronizzatore	Brida de sincronizacion	1
04	8875646	REACTION PLATE	Reaktionsplatte	Plaque de réaction	piastra di reazione	Placa de reaccion	1
05	DMX-8-0806	SCREW	Schraube	Vis	Vite	Tornillo	M8 X 20MM
06	8870848	REACTION PLATE	Reaktionsplatte	Plaque de réaction	piastra di reazione	Placa de reaccion	3
07	8877442	SYNCHRO RING	Synchronring	Anneau de synchro	Andello sincronizzatore	Anillo sincro.	1
08	X8870344	CIRCLIP	Seegerring	Circlip	Anello elastico	Anillo elastico	1
09	X8870341	CIRCLIP - INT/L PLAIN	Seegerring	Circlip	Anello elastico	Anillo elastico	1
10	X8870844	BALL BEARING	Kugellager	Roulement à billes	cuscinetto a sfere	Cojinete de bolas	1
11	8875881	FIXED HUB	Festnabe	Moyeu fixe	mozzo fisso	Cubo fijo	1
12	X8870355	ROLLER	Rolle	Rouleau	rullo	Rodillo	9
13	8870352	PLUNGER	Kolben	Plongeur	pistoncino	Vástago	9
14	8870444	SPRING	Feder	Ressort	Molla	Ballesta	9
15	X8870341	CIRCLIP - INT/L PLAIN	Seegerring	Circlip	Anello elastico	Anillo elastico	1
16	8873041	SLIDING SLEEVE	Schiebemuffe	Anneau baladeur	Manicotto scorrevole	Casquillo deslizante	1
17	X8875296	CIRCLIP	Seegerring	Circlip	Anello elastico	Anillo elastico	1

**Y08024**

**Range Section**

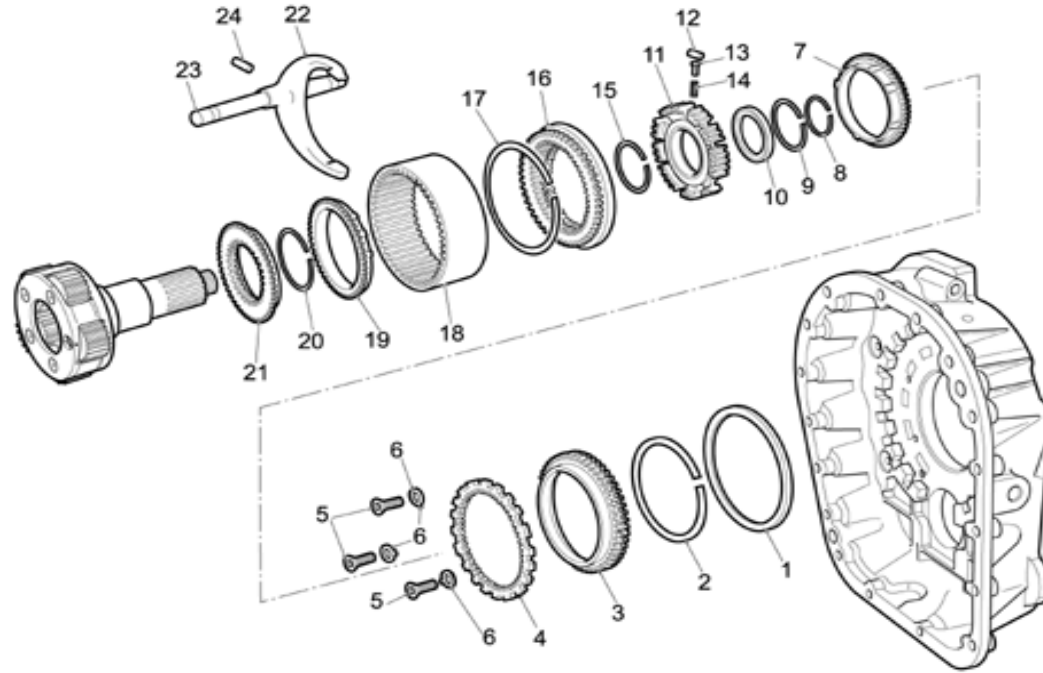

9 SR-12

Part No:	English:	Deutsch:	Français:	Italiano:	Espanol:	Notes	QTY:
18	8872680	ANNULUS	Planetenrad	Roue planetaire	Ingranaggio planetar	Rueda planetar	1
19	8877442	SYNCHRO RING	Synchronring	Anneau de synchro	Andello sincronizzatore	Anillo sincro.	1
20	X8870342	CIRCLIP	Seegerring	Circlip	Anello elastico	Anillo elastico	1
21	8877323	SYNCHRO FLANGE	SynchronFlansch	Bride de Synchro	Flangia sincronizzatore	Brida de sincronizacion	1
22	8872737	HI-LO SHIFT FORK	Hoch-Niedrig-Schaltgabel	Fourchette de sélection haut-ba	forcella selezione cambio gam	Horquilla selección cambio gam	1
23	8872626	HI-LO SHIFT ROD	Hoch-Niedrig-Schaltstange	Biellette de sélection haut-bas	asta selezione cambio gamma	Varilla selección cambio gama	1
24	X8870726	DOWEL	Dübel, stift	(Douille)Goujon Perdu	Spina	Punto guia	1

# Y08024

## Air System

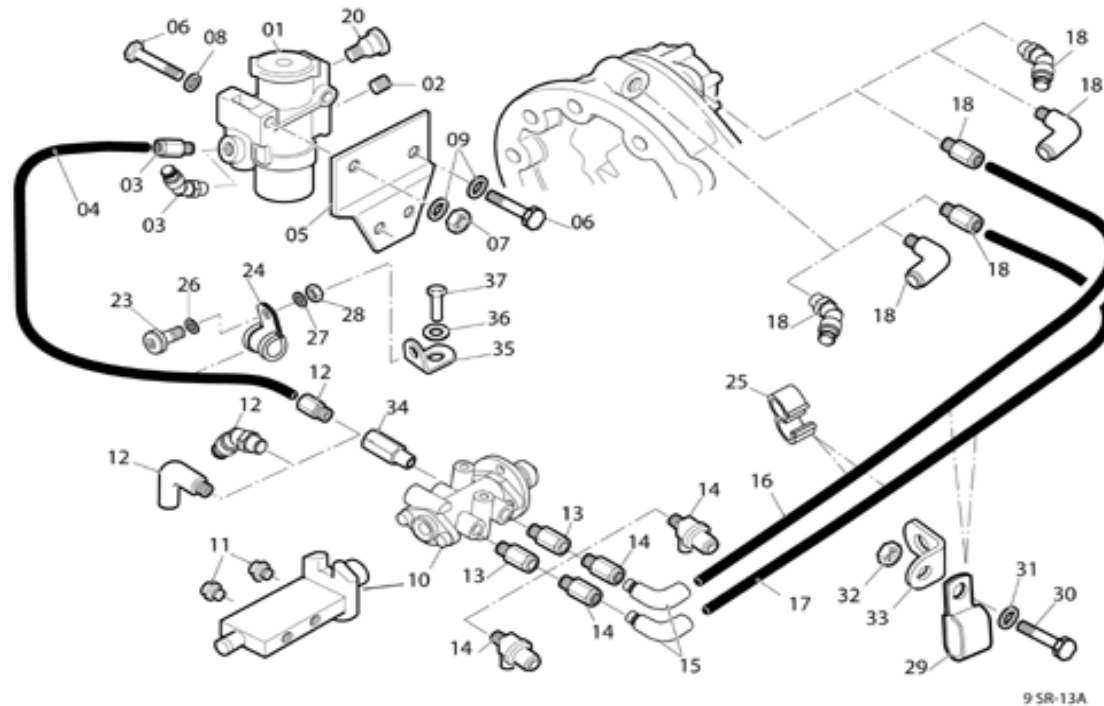

Part No:	English:	Deutsch:	Français:	Italiano:	Espanol:	Notes	QTY:
00	U8880159	RANGE CONTROL ASSY	Bereichssteuerungs-Montage	Commande de gamme complète	comando gamma completo	Conjunto control gama	1
01	X8880109	AIR FILTER REGULATOR	Luftfilterregler	Régul. filtre à air	filtro regolatore dell'aria	Filtro regulador de aire	1
02	DX2013517	PIPE PLUG	Rohrstopfen	Bouchon fileté	tappo a pipa	Tapón roscado	1
03	X8875566	STRAIGHT ADAPTOR	Gerades Element Adapter	Élément droit Adaptateur	diritto Utensile	Elemento recto Utensilt	1
04	X8881545	TUBING	Luftröhrenanlage	Tuyauterie d'air	Tubazione pneumatica	Tubería de aire	6MM
05	8880633	MOUNTING BRACKET	Schienenplatte	Support	Connettore diritto	Abrazadera	1
06	X8880151	TORX SCREW	Schraubbolzen	Boulon	Vite	Perno	2
08	DMX-10-0601	WASHER	Scheibe	Rondelle	Rondella	Arrandela	2
09	DMX-3-0602	SPRING WASHER	Federscheibe	Rondelle grower	Rondella di sicurezza	Arandela elásti	2
10	F96387	RANGE VALVE	Ventil	Valve	valvola	Válvula	1
11	X8877525	BREATHER	Entlüfter	Reniflard	Sfiatatoi	Respiradero	2
12	X8880846	ELBOW ADAPTOR	Winkel	Coude	gomito	Codo	1
14	U8881542	SWIVEL TEE ADAPTOR	Adapter	Adaptateur	Utensile	Utensilt	2
16	X8881545	TUBING	Luftröhrenanlage	Tuyauterie d'air	Tubazione pneumatica	Tubería de aire	6MM
17	X8881545	TUBING	Luftröhrenanlage	Tuyauterie d'air	Tubazione pneumatica	Tubería de aire	6MM
18	X8875566	STRAIGHT ADAPTOR	Gerades Element Adapter	Élément droit Adaptateur	diritto Utensile	Elemento recto Utensilt	2
20	X8877156	STRAIGHT ADAPTOR	Gerades Element Adapter	Élément droit Adaptateur	diritto Utensile	Elemento recto Utensilt	1
25	X8880207	PIPE CLIP	Rohrclip	Clip de pipe	Fascetta	clip del tubo	2

Y08024

Air System

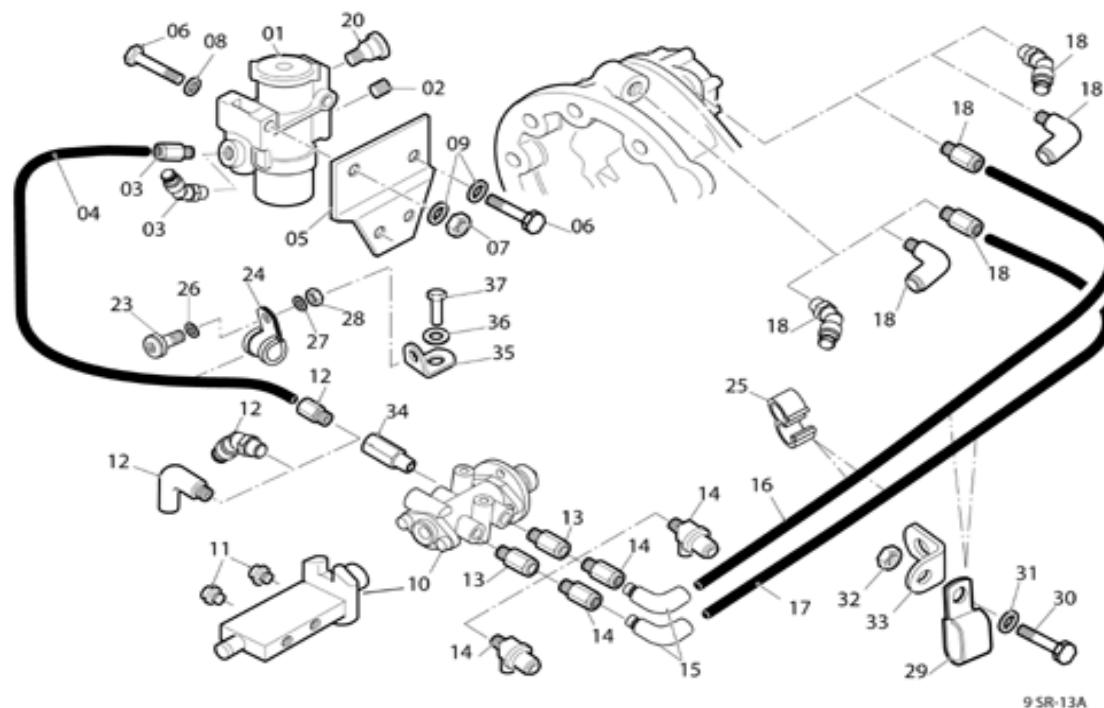

Part No:	English:	Deutsch:	Français:	Italiano:	Espanol:	Notes	QTY:
29 X8880183	PIPE CLIP	Rohrclip	Clip de pipe	Fascetta	clip del tubo		1