



*Powering Business Worldwide*

# Illustrated Parts List

---

**Y08090**

**November 2015**

# Contents

|   |    |
|---|----|
| How To Use The Illustrated Parts List ..... | 3  |
| FRONT BEARING COVER ASSY. ....              | 4  |
| FRONT CASE ASSY.....                        | 5  |
| INPUT SHAFT ASSY.....                       | 7  |
| INTERMEDIATE CASE ASSY.....                 | 8  |
| LAYSHAFT ASSY. ....                         | 10 |
| LRC ASSY.....                               | 12 |
| MAINSHAFT ASSY.....                         | 15 |
| PLANET GEAR SPINDLE ASSY .....              | 18 |
| RANGE ASSY.....                             | 19 |
| RANGE CONTROL ASSY.....                     | 21 |
| REAR CASE ASSY. ....                        | 23 |
| REVERSE IDLER SHAFT.....                    | 25 |
| SELECTOR ASSY. ....                         | 26 |

## How To Use The Illustrated Parts List

The information contained in this document is subject to frequent updates. Therefore, for the latest information available, please visit the interactive Electronic Parts Catalog at <http://www.eaton.com/EatonCom/TruckEurope/TruckEurope/index.htm>

### Model Designation and Nomenclature

- For information regarding Model Designation and Nomenclature, visit <http://www.eaton.com/EatonCom/TruckEurope/TruckEurope/index.htm>

### Kits and Assemblies (K/A's)

- Kits or Assemblies contain groups of individual or assembled parts specially developed for optimal replacement during repair.
- Kits and Assemblies are shown with applicable parts groupings in the parts listings.

### Identifying Kits and Assemblies

A- Part numbers beginning with the letter 'A' are pre-assembled Production Assemblies

K- Part numbers beginning with the letter 'K' are kits that are not assembled

T - Part numbers beginning with the letter 'T' are kits that are not assembled

S- Part numbers beginning with the letter 'S' are pre-assembled Service Assemblies

- Note: Some Production Assemblies do not begin with a letter prefix (Midrange only).

### Illustrations

- Illustrations show parts in assembly groups.
- Item numbers on illustrations correspond with parts listings adjacent to the illustration.(on the same or adjacent page)
- Notes are included on illustrations where additional information is needed.

### Parts Listing

Parts listings are defined by parts groupings and are broken down by service assemblies. Parts listings identify a part for servicing with the following categories

- **ITEM** - Number corresponds to number on illustration for part identification.
- **CURRENT PART** - part number of the part available for service.
- **DESCRIPTION** - part name or description.
- **REPLACED PART** - number of replaced part.
- **QTY** - Quantity required for assembly.
- **NOTES** - unique characteristics or requirements.
- **KITS / ASSYS WHERE NEEDED** - kits or assemblies that contain the part.

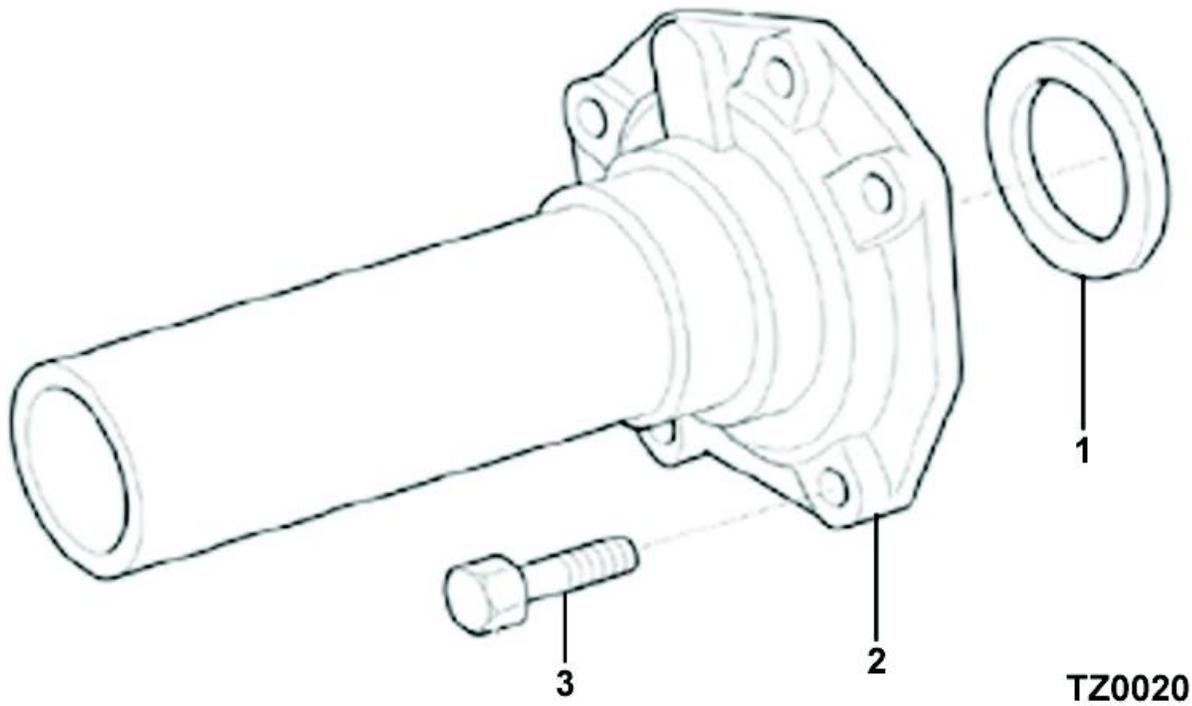

**FRONT BEARING COVER ASSY.**

| Item | Current Part | Description               | Replaced Part | Qty. | Notes             | Kits/Assys Where Needed |
|------|--------------|---------------------------|---------------|------|-------------------|-------------------------|
| 0    | U8877544     | FRONT BEARING COVER ASSY. |               | 1    |                   |                         |
| 1    | X8870760     | OIL SEAL                  |               | 1    |                   |                         |
| 2    | 8877543      | FRONT BEARING COVER       |               | 1    | 66 X 158          |                         |
| 3    | GMX-8-1089   | SCREW                     |               | 5    | M10X25 HEX FLG HD |                         |

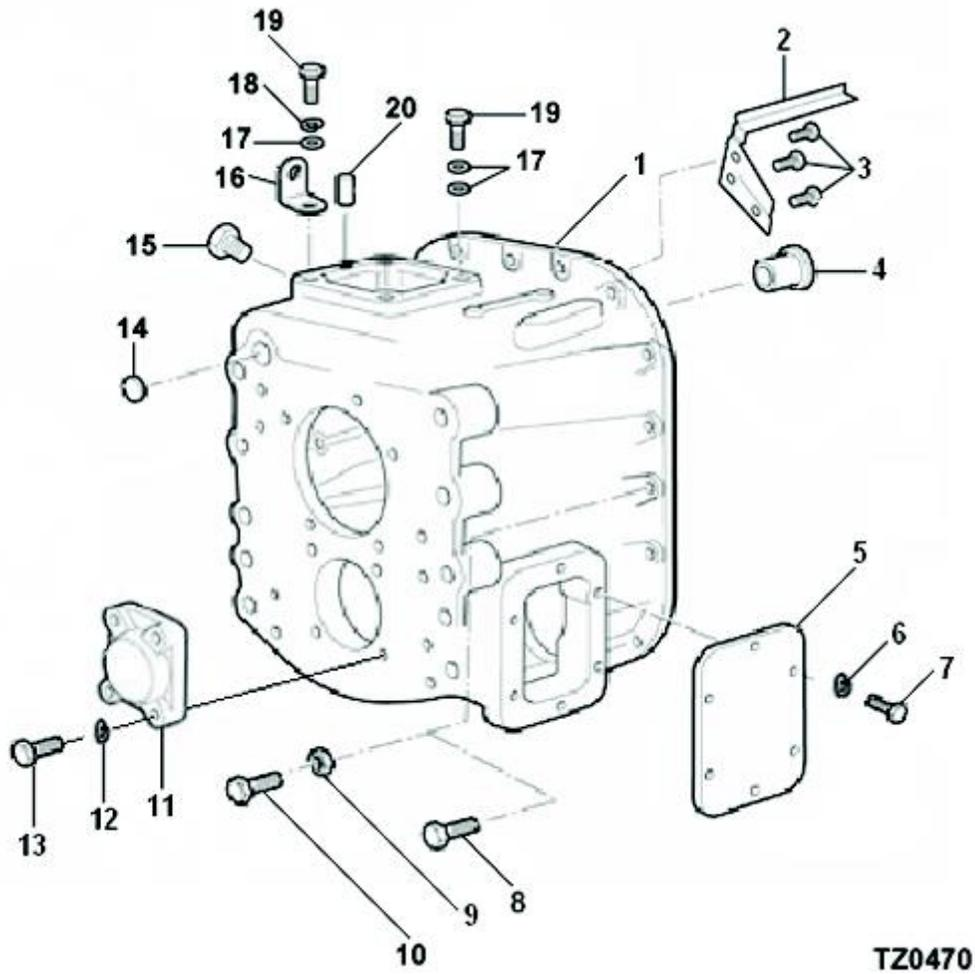

## FRONT CASE ASSY.

| Item | Current Part | Description      | Replaced Part | Qty. | Notes                   | Kits/Assys Where Needed |
|------|--------------|------------------|---------------|------|-------------------------|-------------------------|
| 0    | U8877806     | FRONT CASE ASSY. |               | 1    |                         |                         |
| 1    | 8877807      | FRONT CASE       |               | 1    |                         |                         |
| 2    | 8877758      | OIL TROUGH       |               | 1    |                         |                         |
| 3    | X2014206     | POP RIVET        |               | 3    |                         |                         |
| 4    | 8883756      | BUSH             | 8882415       | 1    | FOR MAIN SELECTOR SHAFT |                         |
| 5    | 2005144      | PTO COVER        |               | 1    |                         |                         |
| 6    | DMX-3-1001   | WASHER SPRING    |               | 6    | M10                     |                         |
| 7    | DMX-8-1001   | SCREW            |               | 6    | M10 X 20 HEX HD         |                         |
| 8    | MX-8-1079    | BOLT             |               | 4    | M10X40                  |                         |
| 9    | MX-9-1005    | NUT              |               | 14   | M10X1.5                 |                         |

| Item | Current Part | Description               | Replaced Part | Qty. | Notes           | Kits/Assys Where Needed |
|------|--------------|---------------------------|---------------|------|-----------------|-------------------------|
| 10   | MX-8-1080    | SCREW                     |               | 14   | M10-58 FLG HD   |                         |
| 11   | 8880554      | BEARING COVER<br>LAYSHAFT |               | 1    |                 |                         |
| 12   | DMX-3-1201   | SPRING WASHER             |               | 4    | M12             |                         |
| 13   | DMX-8-1209   | SCREW                     |               | 4    | M12 X 25 HEX HD |                         |
| 14   | GX8870278    | CUP PLUG                  |               | 1    |                 |                         |
| 15   | X8876793     | DETENT ASSY.              |               | 1    |                 |                         |
| 16   | GX8879212    | LIFTING EYE               |               | 1    | 15 MM           |                         |
| 17   | DX11245      | WASHER                    |               | 7    | M10             |                         |
| 18   | DMX-3-1001   | WASHER SPRING             |               | 4    | M10             |                         |
| 19   | DMX-8-1005   | BOLT                      |               | 4    | M10 X 55        |                         |
| 20   | X8870542     | DOWEL                     |               | 2    | 8,0 DIA X 16    |                         |

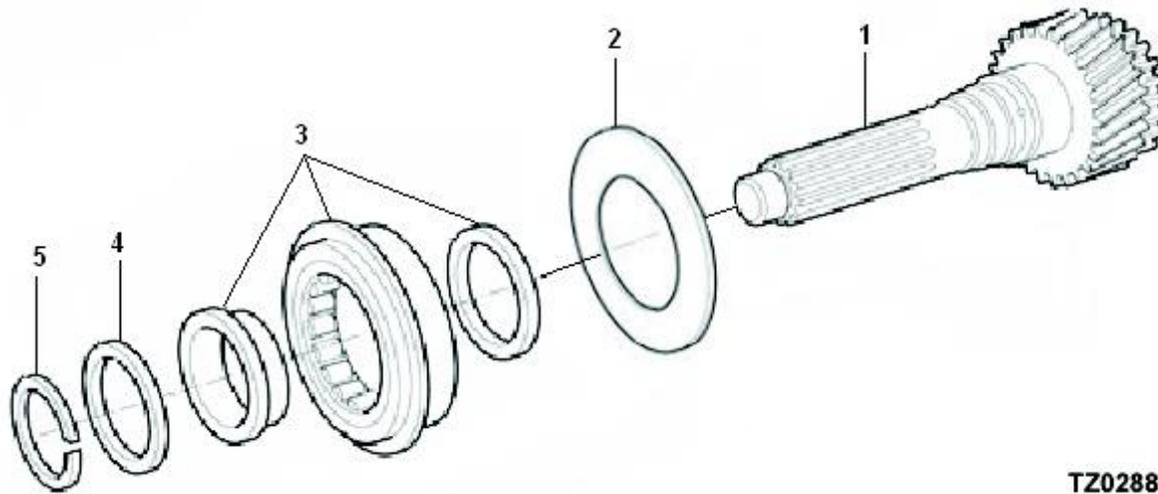

**TZ0288**

### INPUT SHAFT ASSY.

| Item | Current Part | Description           | Replaced Part | Qty. | Notes          | Kits/Assys Where Needed |
|------|--------------|-----------------------|---------------|------|----------------|-------------------------|
| 0    | U8880147     | INPUT SHAFT ASSEMBLY  |               | 1    |                |                         |
| 1    | 8877837      | INPUT SHAFT           |               | 1    |                |                         |
| 2    | 8877429      | SPACER BEARING SHIELD |               | 1    |                |                         |
| 3    | X8872593     | INPUT SHAFT BEARING   |               | 1    |                |                         |
| 4    | 8877692      | SPACER - GRADED 3.10  |               | 1    | PACK: U8877691 |                         |
| 4    | 8877693      | SPACER - GRADED 3.15  |               | 1    | PACK: U8877691 |                         |
| 4    | 8877694      | SPACER - GRADED 3.20  |               | 1    | PACK: U8877691 |                         |
| 4    | 8877695      | SPACER - GRADED 3.25  |               | 1    | PACK: U8877691 |                         |
| 4    | 8877696      | SPACER - GRADED 3.30  |               | 1    | PACK: U8877691 |                         |
| 4    | 8877697      | SPACER - GRADED 3.35  |               | 1    | PACK: U8877691 |                         |
| 4    | 8877698      | SPACER - GRADED 3.40  |               | 1    | PACK: U8877691 |                         |
| 4    | 8877699      | SPACER - GRADED 3.45  |               | 1    | PACK: U8877691 |                         |
| 4    | 8877700      | SPACER - GRADED 3.50  |               | 1    | PACK: U8877691 |                         |
| 4    | U8877691     | SPACER - GRADED PACK  |               | 1    |                |                         |
| 5    | X8877706     | CIRCLIP               |               | 1    |                |                         |

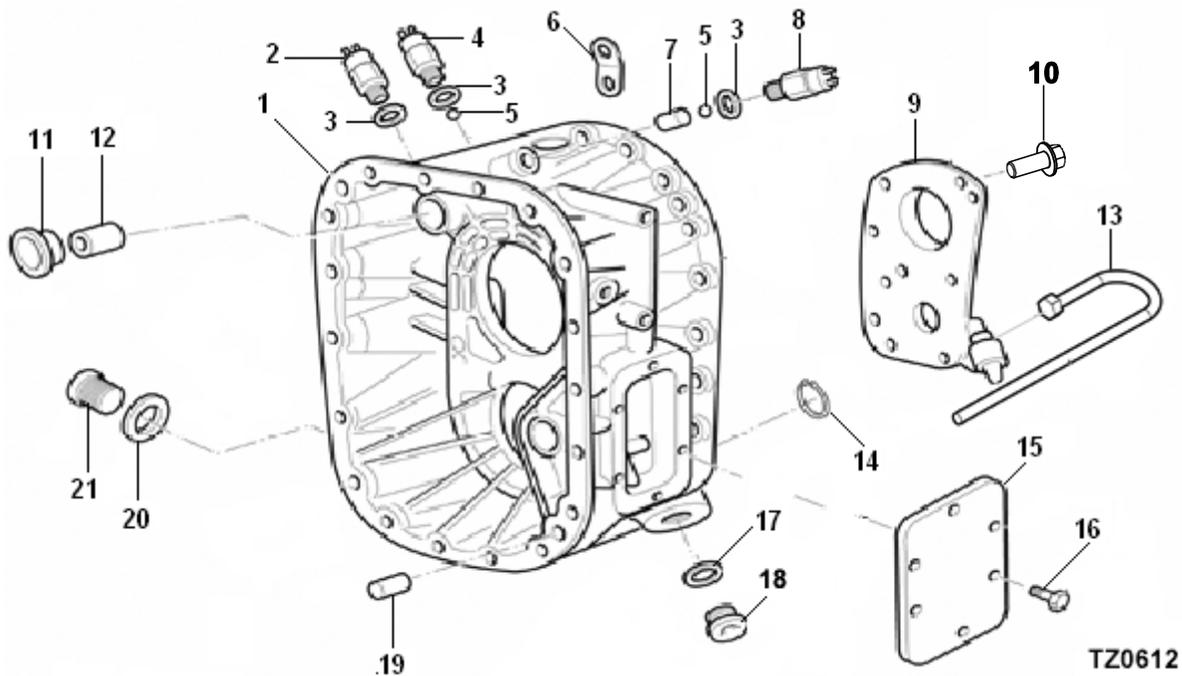

## INTERMEDIATE CASE ASSY.

| Item | Current Part | Description                 | Replaced Part | Qty. | Notes                   | Kits/Assys Where Needed |
|------|--------------|-----------------------------|---------------|------|-------------------------|-------------------------|
| 0    | U8877355     | INTERMEDIATE CASE ASSY.     |               | 1    |                         |                         |
| 1    | 8877354      | INTERMEDIATE CASE           |               | 1    |                         |                         |
| 2    | GX2771532    | SWITCH REVERSE / RANGE      |               | 1    |                         |                         |
| 3    | 5568510      | O-RING                      |               | 3    |                         |                         |
| 4    | 8880315      | NEUTRAL SWITCH              |               | 1    |                         |                         |
| 5    | X8870711     | BALL                        |               | 2    | DIA.14                  |                         |
| 6    | GX8879211    | LIFTING EYE                 |               | 1    |                         |                         |
| 7    | 8875267      | PIN INTERLOCK               |               | 1    |                         |                         |
| 8    | GX2771532    | SWITCH REVERSE / RANGE      |               | 1    |                         |                         |
| 9    | U8883827     | OIL PUMP ASSY.              | U8877604      | 1    |                         |                         |
| 10   | GMX-8-1089   | SCREW                       |               | 8    | M10X25 HEX FLG HD       |                         |
| 11   | 8883756      | BUSH                        | 8882415       | 1    | FOR MAIN SELECTOR SHAFT |                         |
| 12   | X8871377     | BUSH                        |               | 1    |                         |                         |
| 13   | U8877597     | OIL STRAINER & SUCTION TUBE |               | 1    |                         |                         |

| Item | Current Part | Description                 | Replaced Part | Qty. | Notes             | Kits/Assys Where Needed |
|------|--------------|-----------------------------|---------------|------|-------------------|-------------------------|
| 14   | X8881424     | CIRCLIP                     |               | 1    |                   |                         |
| 15   | 8881616      | PTO PROVISION COVER         |               | 1    |                   |                         |
| 16   | GMX-8-1088   | SCREW                       |               | 6    | M12X25 HEX FLG HD |                         |
| 17   | X8880469     | WASHER-OIL STRAINER / DRAIN |               | 1    |                   |                         |
| 18   | GX8876352    | PLUG OIL STRAINER           |               | 1    |                   |                         |
| 19   | X8870543     | DOWEL                       |               | 2    | 16,0 DI X 30,5    |                         |
| 20   | X8880519     | WASHER-FILL/DRAIN FL        |               | 1    |                   |                         |
| 21   | GX8874942    | OIL FILLER PLUG             |               | 1    |                   |                         |

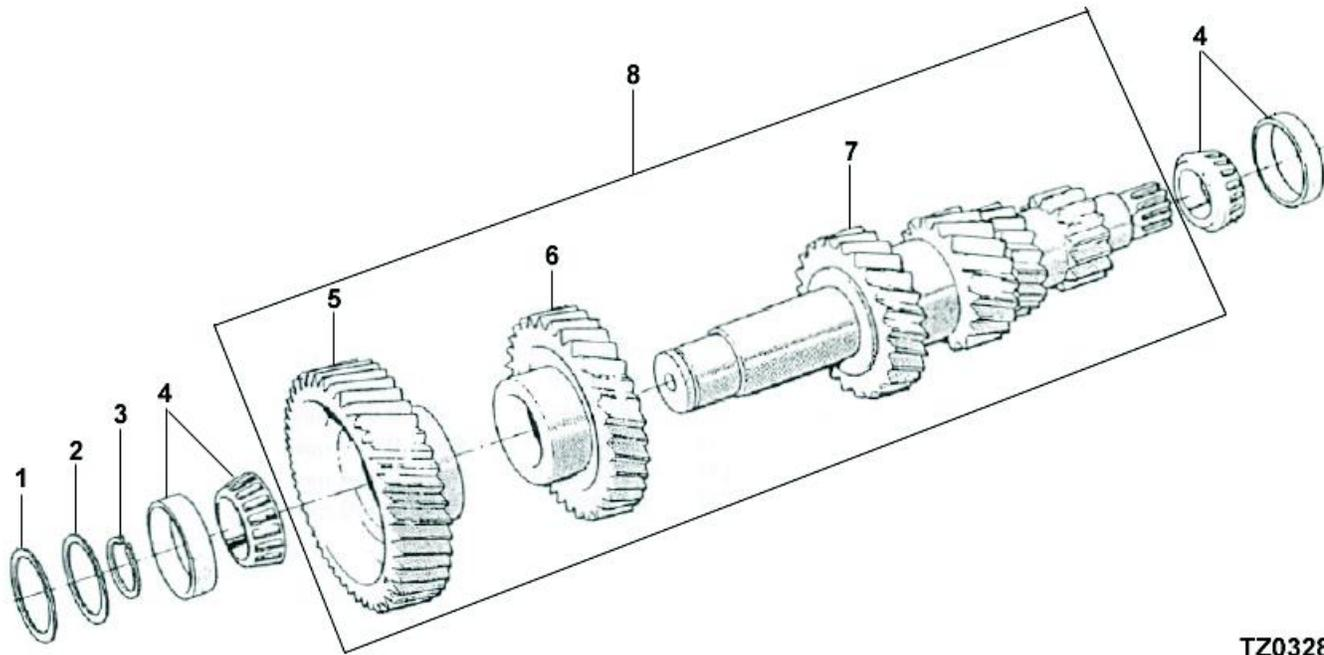

**TZ0328**

**LAYSHAFT ASSY.**

| Item | Current Part | Description                 | Replaced Part | Qty. | Notes   | Kits/Assys Where Needed |
|------|--------------|-----------------------------|---------------|------|---------|-------------------------|
| 1    | 8875879      | SPACER                      |               | 1    |         |                         |
| 2    | F88891       | SHIM                        |               | 1    | S=0,051 |                         |
| 2    | F88892       | SHIM                        |               | 1    | S=0,127 |                         |
| 2    | F88893       | SHIM                        |               | 1    | S=0,254 |                         |
| 2    | F88894       | SHIM                        |               | 1    | S=0,508 |                         |
| 2    | U8877535     | SHIM PACK                   |               | 1    |         |                         |
| 2    | X8882272     | SHIM                        |               | 1    | S=1,200 |                         |
| 3    | U8877534     | CIRCLIP GRADED PACK         |               | 1    |         |                         |
| 3    | X8870370     | GR.C/CLIP 40 DIA. X 2.12 MM |               | 1    |         |                         |
| 3    | X8870371     | GR.C/CLIP 40 DIA. X 2.07 MM |               | 1    |         |                         |
| 3    | X8870372     | GR.C/CLIP 40 DIA X 2.02 MM  |               | 1    |         |                         |
| 3    | X8871536     | GR.C/CLIP 40 DIA. X 1.97 MM |               | 1    |         |                         |
| 3    | X8871537     | GR.C/CLIP 40 DIA. X 1.92 MM |               | 1    |         |                         |
| 3    | X8871538     | GR.C/CLIP 40 DIA. X 1.87 MM |               | 1    |         |                         |

| Item | Current Part | Description                    | Replaced Part | Qty. | Notes | Kits/Assys Where Needed |
|------|--------------|--------------------------------|---------------|------|-------|-------------------------|
| 3    | X8871539     | GR.C/CLIP 40 DIA. X 1.82<br>MM |               | 1    |       |                         |
| 3    | X8871540     | GR.C/CLIP 40 DIA. X 1.77<br>MM |               | 1    |       |                         |
| 4    | X8875587     | BEARING ASSEMBLY               |               | 2    |       |                         |
| 5    | 8876437      | GEAR LAYSHAFT DRIVE            |               | 1    |       |                         |
| 6    | 8880741      | GEAR LAYSHAFT 3RD              |               | 1    |       |                         |
| 7    | 8876947      | LAYSHAFT                       |               | 1    |       |                         |
| 8    | U8880745     | LAYSHAFT ASSY.                 |               | 1    |       |                         |

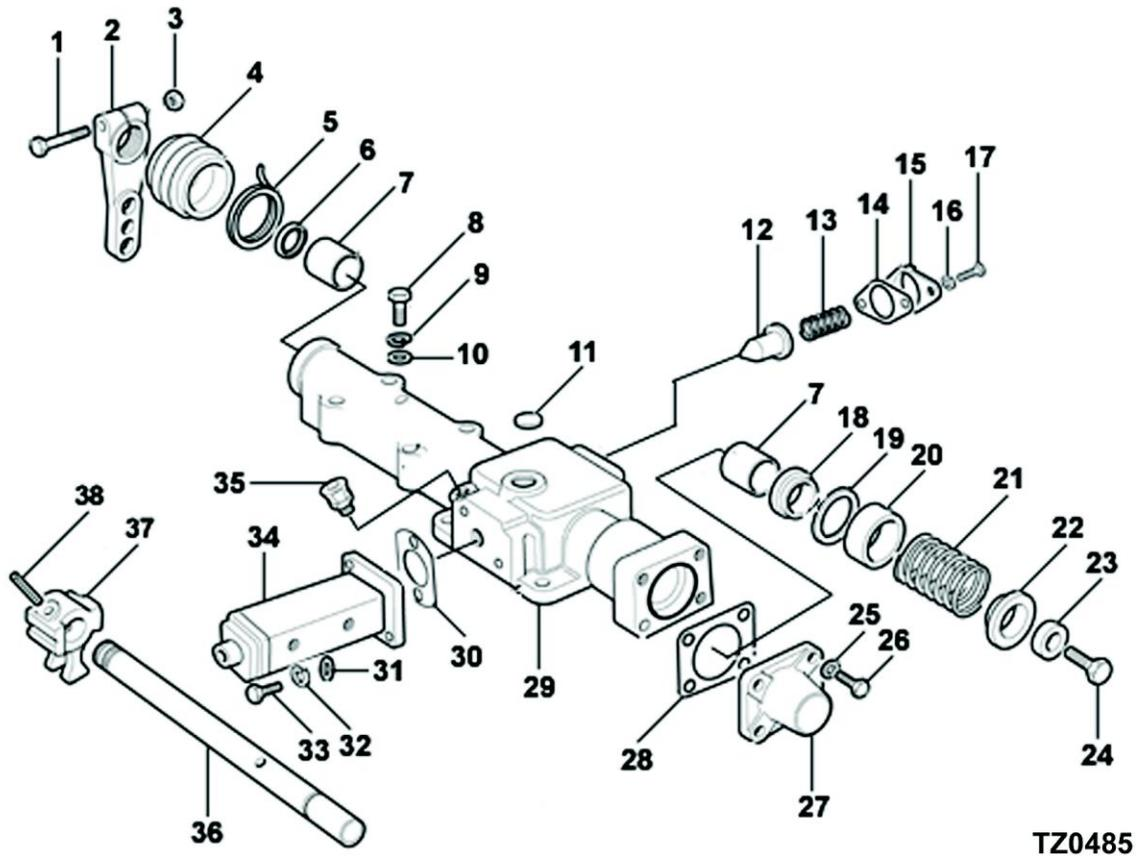

TZ0485

## LRC ASSY.

| Item | Current Part | Description   | Replaced Part | Qty. | Notes   | Kits/Assys Where Needed |
|------|--------------|---------------|---------------|------|---------|-------------------------|
| 0    | U8880476     | LRC ASSY.     |               | 1    |         |                         |
| 1    | GMX-8-1007   | BOLT          |               | 1    | M10X50  |                         |
| 2    | D8876842     | OUTER LEVER   |               | 1    |         |                         |
| 3    | GMX-9-1005   | NUT           |               | 1    | M10X1.5 |                         |
| 4    | 14975        | BOOT          |               | 1    |         |                         |
| 5    | F96430       | CABLE TIE     |               | 1    |         |                         |
| 6    | X8881481     | OIL SEAL      |               | 1    |         |                         |
| 7    | X8871377     | BUSH          |               | 2    |         |                         |
| 8    | GMX-8-1005   | BOLT          |               | 4    | M10X55  |                         |
| 9    | GMX-3-1001   | SPRING WASHER |               | 4    | M10     |                         |
| 10   | GX11245      | WASHER PLAIN  |               | 4    | M10     |                         |

| Item | Current Part | Description          | Replaced Part | Qty. | Notes        | Kits/Assys Where Needed |
|------|--------------|----------------------|---------------|------|--------------|-------------------------|
| 11   | GX8871486    | EXPANSION PLUG       |               | 1    |              |                         |
| 12   | 8880238      | PLUNGER              |               | 1    |              |                         |
| 13   | 8874897      | SPRING COMPRESSION   |               | 1    |              |                         |
| 14   | 8870590      | GASKET               |               | 1    |              |                         |
| 15   | GX8870259    | DETENT COVER         |               | 1    |              |                         |
| 16   | GMX-3-0801   | WASHER SPRING        |               | 2    | M8           |                         |
| 17   | GMX-8-0801   | SCREW                |               | 2    | M8X14        |                         |
| 18   | 8871374      | SPRING RETAINING CUP |               | 1    |              |                         |
| 19   | 8871481      | WASHER STOP          |               | 1    |              |                         |
| 20   | 8872637      | SPACER               |               | 1    |              |                         |
| 21   | 8871395      | SPRING COMPRESSION   |               | 1    |              |                         |
| 22   | 8872639      | SPRING RETAINER BUSH |               | 1    |              |                         |
| 23   | 8871478      | WASHER PLAIN         |               | 1    | M8           |                         |
| 24   | GMX-8-0803   | SCREW                |               | 1    | M8X25        |                         |
| 25   | GMX-3-0801   | WASHER SPRING        |               | 4    | M8           |                         |
| 26   | GMX-8-0824   | SCREW                |               | 4    | M8X30 HEX HD |                         |
| 27   | 8876041      | END COVER            |               | 1    |              |                         |
| 28   | 8873734      | GASKET               |               | 1    |              |                         |
| 29   | 8875113      | LRC HOUSING          |               | 1    |              |                         |
| 30   | F91353       | JOINT                |               | 1    |              |                         |
| 31   | GMX-10-0601  | WASHER               |               | 2    | M6           |                         |
| 32   | GMX-3-0602   | WASHER SPRING        |               | 2    | M6           |                         |
| 33   | GMX-8-0629   | SCREW                |               | 2    | M6 X 20      |                         |
| 34   | F96387       | RANGE VALVE          |               | 1    |              |                         |
| 35   | X2014210     | BREATHER             |               | 1    |              |                         |
| 36   | GX8880071    | SHIFT ROD            |               | 1    |              |                         |
| 37   | 8877659      | INNER STRIKING LEVER |               | 1    |              |                         |

| Item | Current Part | Description | Replaced Part | Qty. | Notes         | Kits/Assys Where Needed |
|------|--------------|-------------|---------------|------|---------------|-------------------------|
| 38   | X8871378     | DOWEL       |               | 1    | 10,0 DIA X 44 |                         |

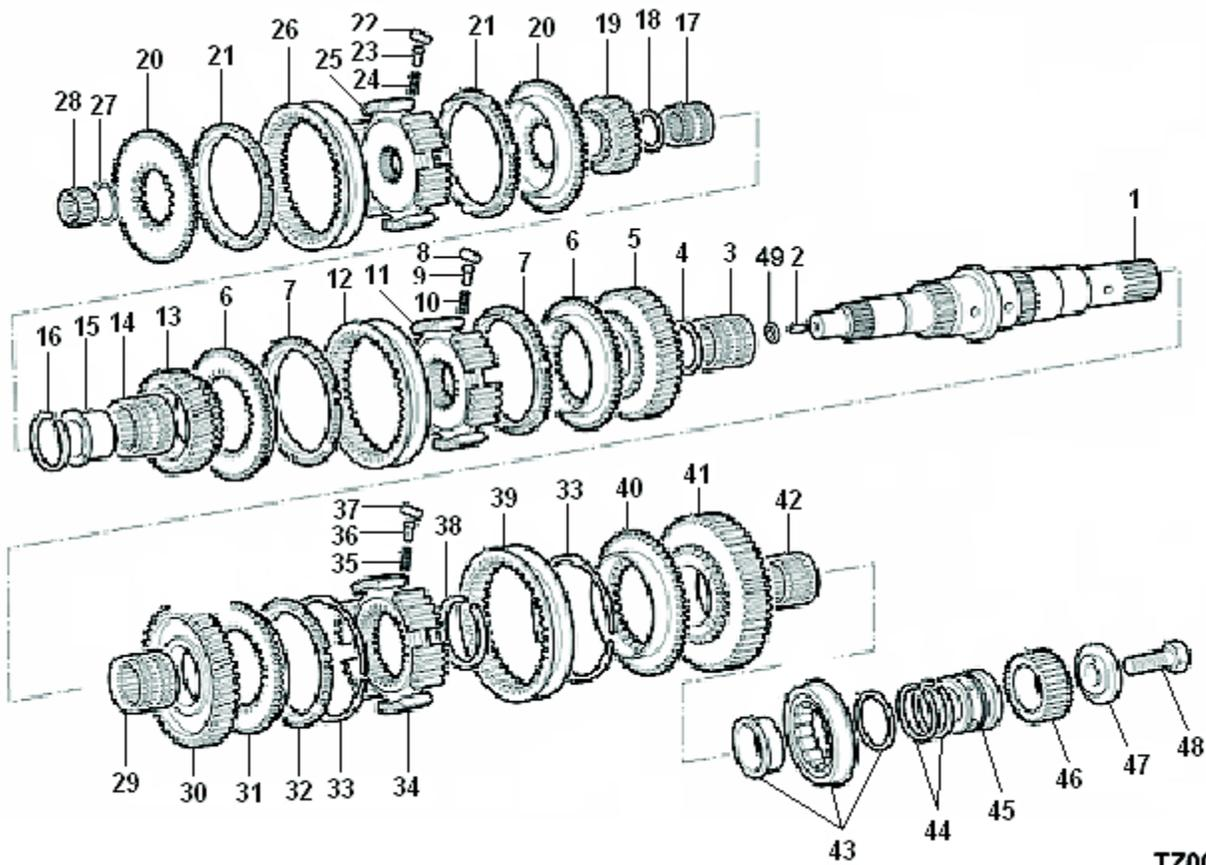

TZ0044

## MAINSHAFT ASSY.

| Item | Current Part | Description             | Replaced Part | Qty. | Notes          | Kits/Assys Where Needed |
|------|--------------|-------------------------|---------------|------|----------------|-------------------------|
| 1    | U8877167     | MAINSHAFT SUB ASSY.     |               | 1    |                |                         |
| 2    | X14851       | DOWEL                   |               | 1    | 5/16 DI X 1.50 |                         |
| 3    | X8872233     | NEEDLE ROLLER BRG. ASSY |               | 1    |                |                         |
| 4    | 8872589      | GEAR SPACER 1ST         |               | 1    |                |                         |
| 5    | 8876948      | GEAR MAINSHAFT 1ST      |               | 1    |                |                         |
| 6    | 8877321      | SYNCHRO FLANGE 1/2/3/4  |               | 2    |                |                         |
| 7    | 8877441      | SYNCHRO RING            |               | 2    |                |                         |
| 8    | X8870356     | ROLLER                  |               | 3    |                |                         |
| 9    | 8870352      | PLUNGER                 |               | 3    |                |                         |
| 10   | 8870444      | SPRING COMPRESSION      |               | 3    |                |                         |
| 11   | 8875571      | HUB-FIXED, 1ST/2ND      |               | 1    |                |                         |
| 12   | 8875377      | SLIDING SLEEVE          |               | 1    |                |                         |

| Item | Current Part | Description                        | Replaced Part | Qty. | Notes          | Kits/Assys Where Needed |
|------|--------------|------------------------------------|---------------|------|----------------|-------------------------|
| 13   | 8876949      | GEAR MAINSHAFT 2ND                 |               | 1    |                |                         |
| 14   | X8872233     | NEEDLE ROLLER BRG.<br>ASSY         |               | 1    |                |                         |
| 15   | 8882868      | SLEEVE MAINSHAFT<br>BEARING        |               | 1    |                |                         |
| 16   | U8882558     | GRADED CIRCLIP PACK                |               | 1    |                |                         |
| 16   | X8870534     | GR.CIRCLIP 46 DIA. X 2.10<br>MM    |               | 1    | PACK: U8882558 |                         |
| 16   | X8870535     | GR.CIRCLIP 46 DIA. X 2.05<br>MM    |               | 1    | PACK: U8882558 |                         |
| 16   | X8870536     | GR.CIRCLIP 46 DIA. X 2.00<br>MM    |               | 1    | PACK: U8882558 |                         |
| 16   | X8883040     | CIRCLIP GRADED 46 DIA<br>X2.15 MM  |               | 1    | PACK: U8882558 |                         |
| 16   | X8883041     | CIRCLIP GRADED 46 DIA<br>X 2.20 MM |               | 1    | PACK: U8882558 |                         |
| 17   | X8870180     | NEEDLE BEARING                     |               | 1    |                |                         |
| 18   | 8872588      | GEAR SPACER 4TH                    |               | 1    |                |                         |
| 19   | 8880740      | GEAR MAINSHAFT 3RD                 |               | 1    |                |                         |
| 20   | 8877321      | SYNCHRO FLANGE 1/2/3/4             |               | 2    |                |                         |
| 21   | 8877441      | SYNCHRO RING                       |               | 2    |                |                         |
| 22   | X8870356     | ROLLER                             |               | 3    |                |                         |
| 23   | 8870352      | PLUNGER                            |               | 3    |                |                         |
| 24   | 8870444      | SPRING COMPRESSION                 |               | 3    |                |                         |
| 25   | 8875554      | FIXED HUB 3RD/4TH                  |               | 1    |                |                         |
| 26   | 8875377      | SLIDING SLEEVE                     |               | 1    |                |                         |
| 27   | U8877531     | GRADED CIRCLIP PACK                |               | 1    |                |                         |
| 27   | X8870370     | GR.C/CLIP 40 DIA. X 2.12<br>MM     |               | 1    |                |                         |
| 27   | X8870371     | GR.C/CLIP 40 DIA. X 2.07<br>MM     |               | 1    |                |                         |
| 27   | X8870372     | GR.C/CLIP 40 DIA X 2.02<br>MM      |               | 1    |                |                         |
| 28   | X8870305     | NEEDLE BRG.ROLLER<br>ASSY          |               | 1    |                |                         |
| 29   | X8872233     | NEEDLE ROLLER BRG.<br>ASSY         |               | 1    |                |                         |
| 30   | 8876477      | GEAR MAINSHAFT<br>CRAWLER          |               | 1    |                |                         |

| Item | Current Part | Description                    | Replaced Part | Qty. | Notes         | Kits/Assys Where Needed |
|------|--------------|--------------------------------|---------------|------|---------------|-------------------------|
| 31   | 8880059      | SYNCHRO FLANGE<br>CRAWLER      |               | 1    |               |                         |
| 32   | 8876105      | SYNCHRO RING                   |               | 2    |               |                         |
| 33   | X8873994     | CIRCLIP SYNCHRO.<br>ASSY.      |               | 1    |               |                         |
| 34   | 8875604      | FIXED HUB<br>REVERSE/CRAWLER   |               | 1    |               |                         |
| 35   | 8870444      | SPRING COMPRESSION             |               | 3    |               |                         |
| 36   | 8870352      | PLUNGER                        |               | 3    |               |                         |
| 37   | X8870356     | ROLLER                         |               | 3    |               |                         |
| 38   | U8877532     | GRADED CIRCLIP PACK            |               | 1    |               |                         |
| 38   | U8882193     | GRADED CIRCLIP PACK            |               | 1    |               |                         |
| 38   | X8870378     | CIRCLIP-GR.DIA.60 X 2.10<br>MM |               | 1    |               |                         |
| 38   | X8870379     | CIRCLIP-GR.DIA.60 X 2.05<br>MM |               | 1    |               |                         |
| 39   | 8880461      | SLIDING SLEEVE                 |               | 1    |               |                         |
| 40   | 8870415      | SYNCHRO FLANGE<br>REVERSE      |               | 1    |               |                         |
| 41   | 8876478      | GEAR MAINSHAFT<br>REVERSE      |               | 1    |               |                         |
| 42   | X8870178     | NEEDLE ROLLER BRG.<br>ASSY     |               | 1    |               |                         |
| 43   | X8877164     | BEARING REAR<br>MAINSHAFT      |               | 1    |               |                         |
| 44   | X8875532     | SEALING RING                   |               | 2    |               |                         |
| 45   | 8874921      | OIL MUFF                       |               | 1    |               |                         |
| 46   | 8875585      | SUN GEAR                       |               | 1    |               |                         |
| 47   | 8880594      | RETAINER                       |               | 1    |               |                         |
| 48   | X8870699     | SCREW                          |               | 1    | M16X45 HEX HD |                         |
| 49   | 8876298      | RESTRICTOR                     |               | 1    |               |                         |

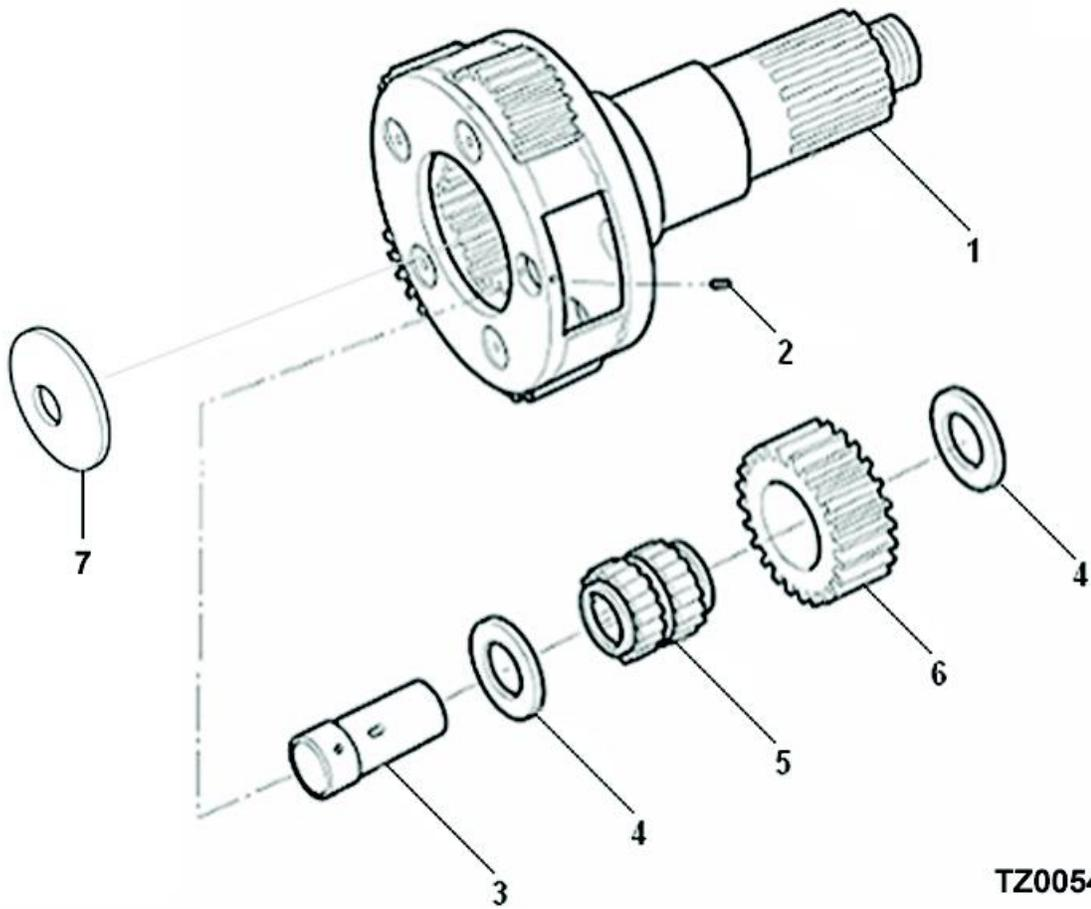

**TZ0054**

## PLANET GEAR SPINDLE ASSY

| Item | Current Part | Description              | Replaced Part | Qty. | Notes              | Kits/Assys Where Needed |
|------|--------------|--------------------------|---------------|------|--------------------|-------------------------|
| 0    | U8877600     | PLANET GEAR SPINDLE ASSY |               | 1    |                    |                         |
| 1    | U8882494     | OUTPUT SHAFT ASSY        |               | 1    |                    |                         |
| 2    | MX-11-0601   | SCREW                    |               | 5    | M6 X 10 SKT HD SET |                         |
| 3    | 8872682      | SPINDLE-PLANET GEAR      |               | 5    |                    |                         |
| 4    | 8876893      | WASHER                   |               | 10   |                    |                         |
| 5    | U8875235     | NEEDLE ROLLER BRG. ASSY. |               | 5    |                    |                         |
| 6    | 8883395      | GEAR PLANET              | 8875586       | 5    |                    |                         |
| 7    | 8877599      | OIL RESTRICTOR           |               | 1    |                    |                         |

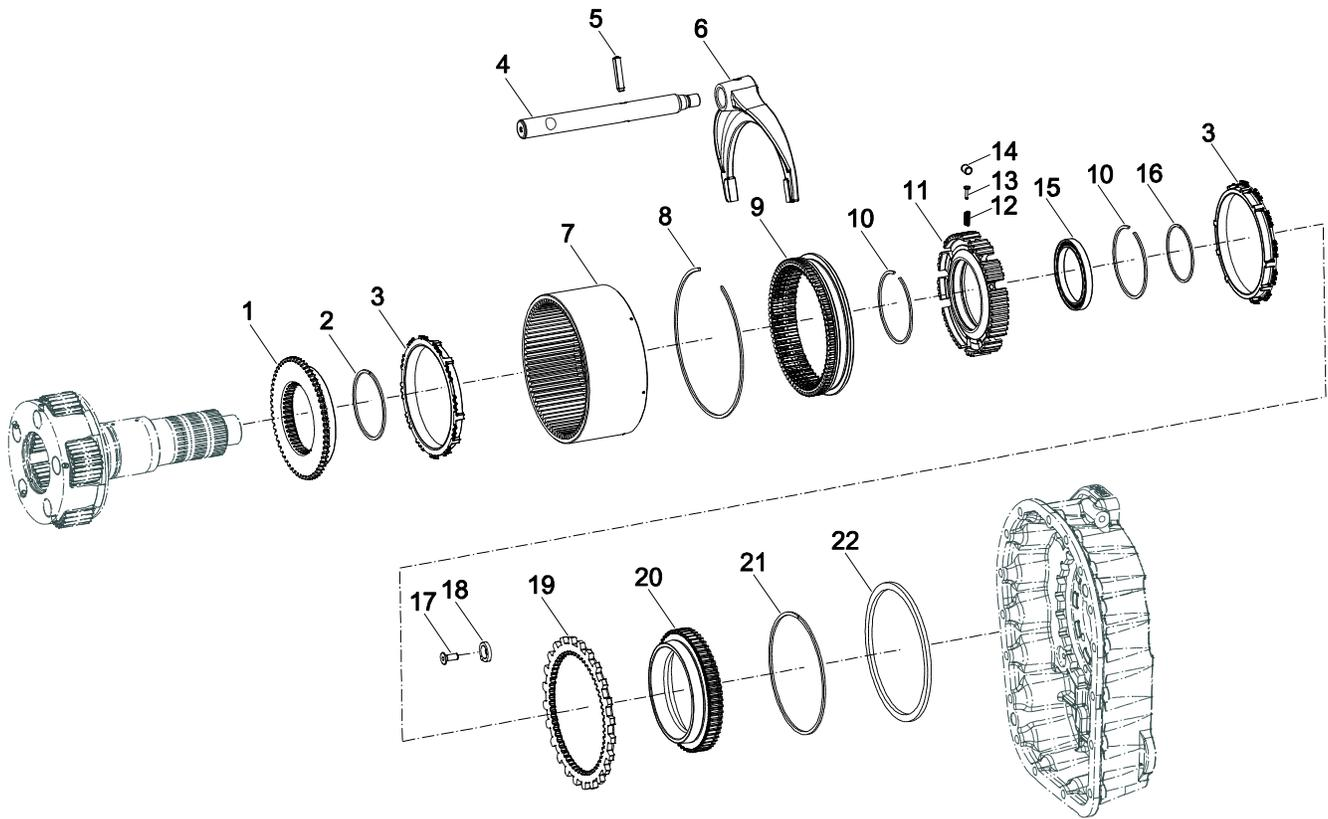

PU0146

**RANGE ASSY.**

| Item | Current Part | Description          | Replaced Part   | Qty. | Notes | Kits/Assys Where Needed |
|------|--------------|----------------------|-----------------|------|-------|-------------------------|
| 1    | 8877323      | SYNCHRO FLANGE       |                 | 1    |       |                         |
| 2    | X8870342     | CIRCLIP              |                 | 1    |       |                         |
| 3    | 8877442      | SYNCHRO RING - RANGE |                 | 2    |       |                         |
| 4    | 8872626      | HI-LO SHIFT ROD      |                 | 1    |       |                         |
| 5    | X8878665     | DOWEL                | X8870726        | 1    |       |                         |
| 6    | 8872737      | HIGH/LOW SHIFT FORK  | 8872737,8883677 | 1    |       |                         |
| 7    | 8872680      | ANNULUS              |                 | 1    |       |                         |
| 8    | X8875296     | CIRCLIP              |                 | 1    |       |                         |
| 9    | 8880522      | SLIDING SLEEVE       |                 | 1    |       |                         |
| 10   | X8870341     | CIRCLIP              |                 | 1    |       |                         |

| Item | Current Part | Description        | Replaced Part | Qty. | Notes | Kits/Assys Where Needed |
|------|--------------|--------------------|---------------|------|-------|-------------------------|
| 11   | 8875881      | FIXED HUB          |               | 1    |       |                         |
| 12   | 8870444      | SPRING COMPRESSION |               | 9    |       |                         |
| 13   | 8870352      | PLUNGER            |               | 9    |       |                         |
| 14   | X8870355     | ROLLER             |               | 9    |       |                         |
| 15   | X8870844     | BEARING            |               | 1    |       |                         |
| 16   | X8870344     | CIRCLIP            |               | 1    |       |                         |
| 17   | GMX-8-0806   | SCREW              |               | 3    | M8X20 |                         |
| 18   | 8870848      | RETAINER           |               | 3    |       |                         |
| 19   | 8875646      | REACTION PLATE     |               | 1    |       |                         |
| 20   | 8877322      | SYNCHRO FLANGE     |               | 1    |       |                         |
| 21   | X8873993     | CIRCLIP            |               | 1    |       |                         |
| 22   | 8870808      | SPACER             |               | 1    |       |                         |

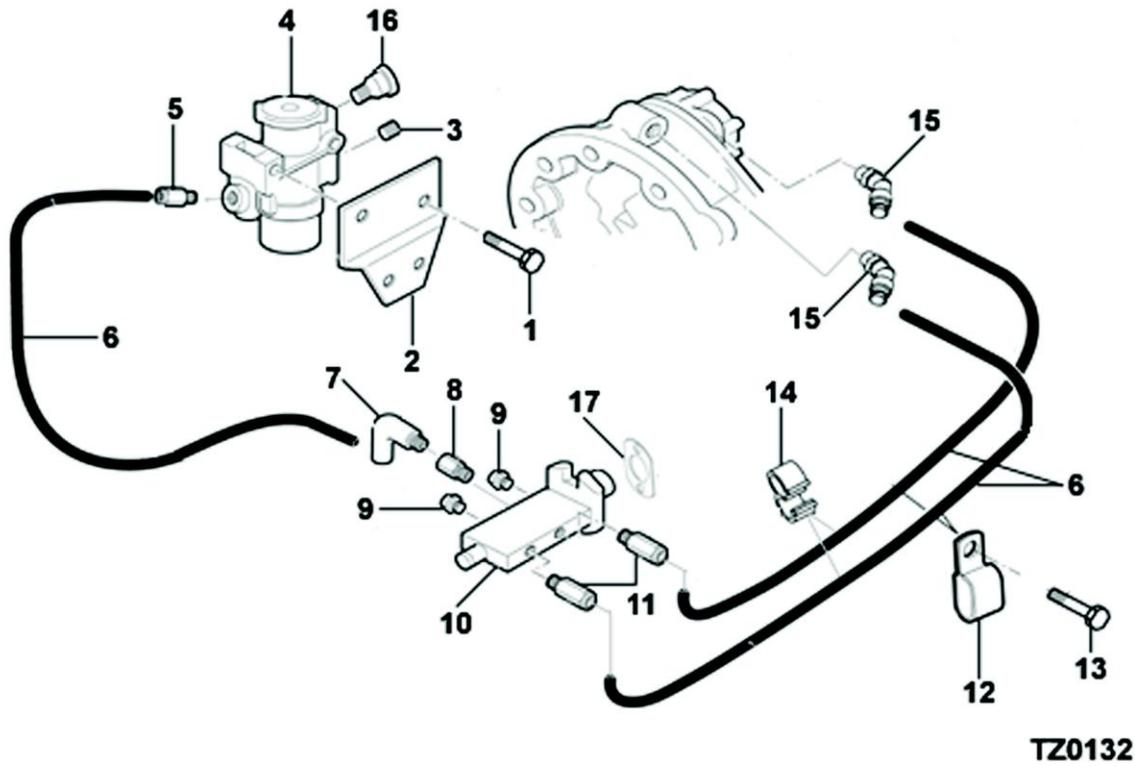

**RANGE CONTROL ASSY.**

| Item | Current Part | Description           | Replaced Part | Qty. | Notes             | Kits/Assys Where Needed |
|------|--------------|-----------------------|---------------|------|-------------------|-------------------------|
| 0    | U8880072     | RANGE CONTROL ASSY.   |               | 1    |                   |                         |
| 1    | X8880151     | SCREW SPIRAL          | GX8880151     | 2    |                   |                         |
| 2    | 8880633      | MOUNTING BRACKET      |               | 1    |                   |                         |
| 3    | GX2013517    | PIPE PLUG             |               | 1    | 1/8               |                         |
| 4    | X8880109     | FILTER REGULATOR      |               | 1    |                   |                         |
| 5    | X8881538     | STRAIGHT ADAPTOR      |               | 1    | 6MM               |                         |
| 6    | X8881545     | NYLON TUBE 6 MM       |               | 3    |                   |                         |
| 7    | X8880846     | ELBOW ARTICULATED     |               | 1    |                   |                         |
| 8    | X8883138     | ADAPTOR G1/8          |               | 2    |                   |                         |
| 9    | X8877525     | BREATHER              |               | 2    | 1/8 WITH FLAP     |                         |
| 10   | F96387       | RANGE VALVE           |               | 1    |                   |                         |
| 11   | X8881538     | STRAIGHT ADAPTOR      |               | 2    | 6MM               |                         |
| 12   | 12152        | HOSE CLAMP            |               | 1    |                   |                         |
| 13   | GMX-8-1088   | SCREW                 |               | 2    | M12X25 HEX FLG HD |                         |
| 14   | X8880545     | PIPE CLIP - TWIN PIPE |               | 2    |                   |                         |

| Item | Current Part | Description                    | Replaced Part | Qty. | Notes     | Kits/Assys Where Needed |
|------|--------------|--------------------------------|---------------|------|-----------|-------------------------|
| 15   | X8881544     | SWIVEL ELBOW<br>ADAPTOR 45 DEG |               | 2    |           |                         |
| 16   | X8877156     | STRAIGHT ADAPTOR               |               | 1    | 3/8 - M10 |                         |
| 17   | F91353       | JOINT                          |               | 1    |           |                         |

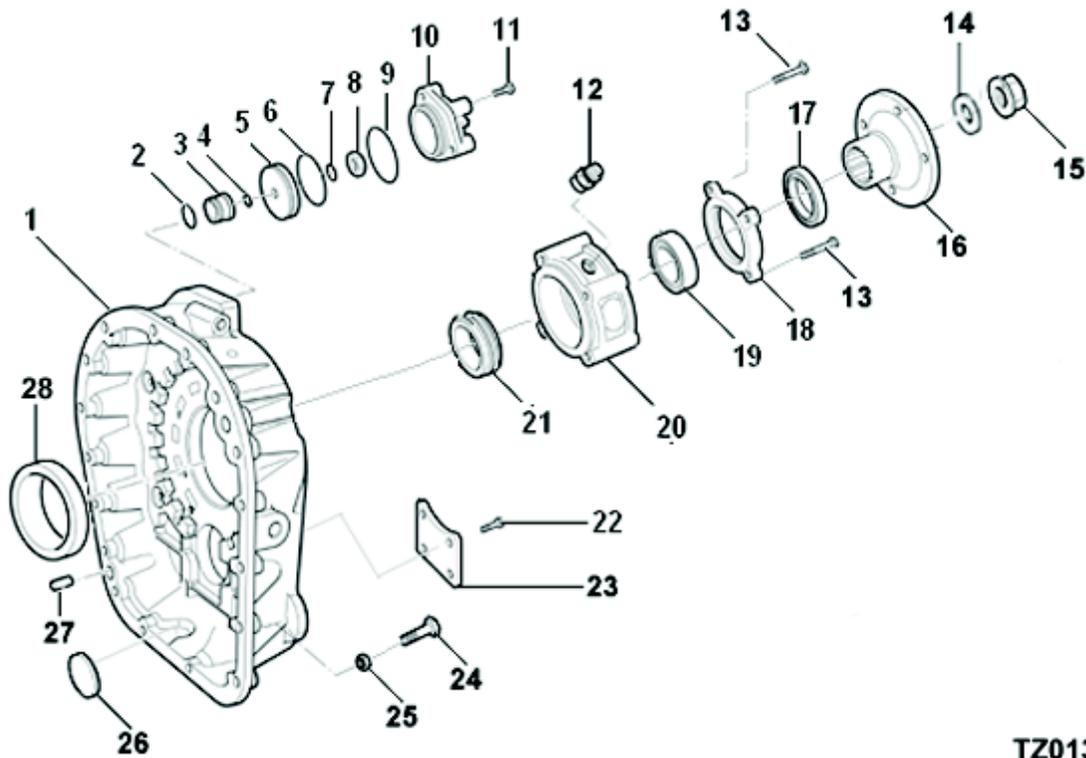

**TZ0131**

**REAR CASE ASSY.**

| Item | Current Part | Description           | Replaced Part | Qty. | Notes             | Kits/Assys Where Needed |
|------|--------------|-----------------------|---------------|------|-------------------|-------------------------|
| 0    | U8880053     | REAR CASE ASSY.       |               | 1    |                   |                         |
| 1    | 8874367      | REAR CASING           |               | 1    |                   |                         |
| 2    | X8875292     | O-RING                |               | 1    |                   |                         |
| 3    | 8878240      | BUSH                  | 8875293       | 1    |                   |                         |
| 4    | X8871258     | O-RING                |               | 1    | DIA.24,5          |                         |
| 5    | 8875179      | PISTON RANGE CYLINDER |               | 1    |                   |                         |
| 6    | 14344        | PISTON O RING         |               | 1    |                   |                         |
| 7    | 14345        | PISTON O RING         |               | 1    |                   |                         |
| 8    | GMX-9-1602   | NUT                   |               | 1    | M16               |                         |
| 9    | X8873008     | O-RING                |               | 1    |                   |                         |
| 10   | 8875430      | CYLINDER-RANGE        |               | 1    |                   |                         |
| 11   | GMX-8-1094   | BOLT                  |               | 3    | M10X55 HEX FLG HD |                         |
| 12   | X8877476     | IMPULSE TRANSMITTER   |               | 1    |                   |                         |

| Item | Current Part | Description         | Replaced Part | Qty. | Notes             | Kits/Assys Where Needed |
|------|--------------|---------------------|---------------|------|-------------------|-------------------------|
| 13   | GMX-8-1095   | BOLT                |               | 3    | M10X95 HEX FLG HD |                         |
| 13   | GMX-8-1096   | BOLT                |               | 1    | M10X95 HEX FLG HD |                         |
| 14   | 8877047      | SPACER              |               | 1    | 77 X 57 X 6       |                         |
| 15   | GX8870553    | NUT                 |               | 1    |                   |                         |
| 16   | D8877079     | COUPLING FLANGE     |               | 1    |                   |                         |
| 17   | X8872722     | OIL SEAL            |               | 1    |                   |                         |
| 18   | 8871992      | REAR COVER          |               | 1    |                   |                         |
| 19   | X8872721     | BEARING             |               | 1    |                   |                         |
| 20   | 8874013      | SPEEDO HOUSING      |               | 1    |                   |                         |
| 21   | 8882427      | ROTOR TACHOGRAPH    |               | 1    |                   |                         |
| 22   | GMX-8-1240   | SCREW               |               | 4    | M12X25 HEX FLG HD |                         |
| 23   | GX8873917    | LAYSHAFT REAR COVER |               | 1    |                   |                         |
| 24   | GMX-8-1080   | BOLT                |               | 17   | M10X58            |                         |
| 25   | GMX-9-1005   | NUT                 |               | 17   | M10X1.5           |                         |
| 26   | 14373        | DISC MAGNET         |               | 1    |                   |                         |
| 27   | X8870543     | DOWEL               |               | 2    | 16,0 DI X 30,5    |                         |
| 28   | 8877603      | RESTRICTOR OIL      |               | 1    |                   |                         |

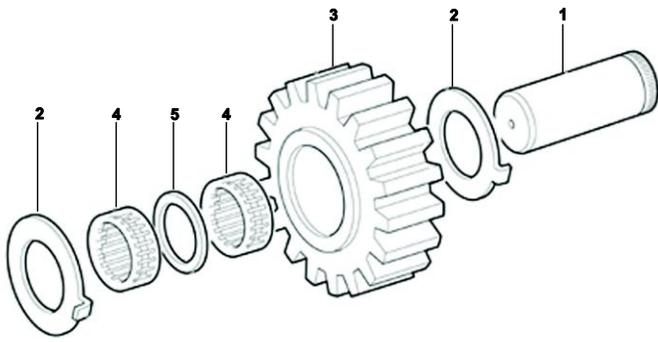

TZ0007

## REVERSE IDLER SHAFT

| Item | Current Part | Description         | Replaced Part | Qty. | Notes | Kits/Assys Where Needed |
|------|--------------|---------------------|---------------|------|-------|-------------------------|
| 1    | 8880069      | REVERSE IDLER SHAFT |               | 1    |       |                         |
| 2    | 8870343      | THRUST WASHER       |               | 2    |       |                         |
| 3    | 8876457      | REVERSE IDLER GEAR  |               | 1    |       |                         |
| 4    | X8872478     | NEEDLE ROLLER BRG   |               | 2    |       |                         |
| 5    | 8872479      | SPACER              |               | 1    |       |                         |

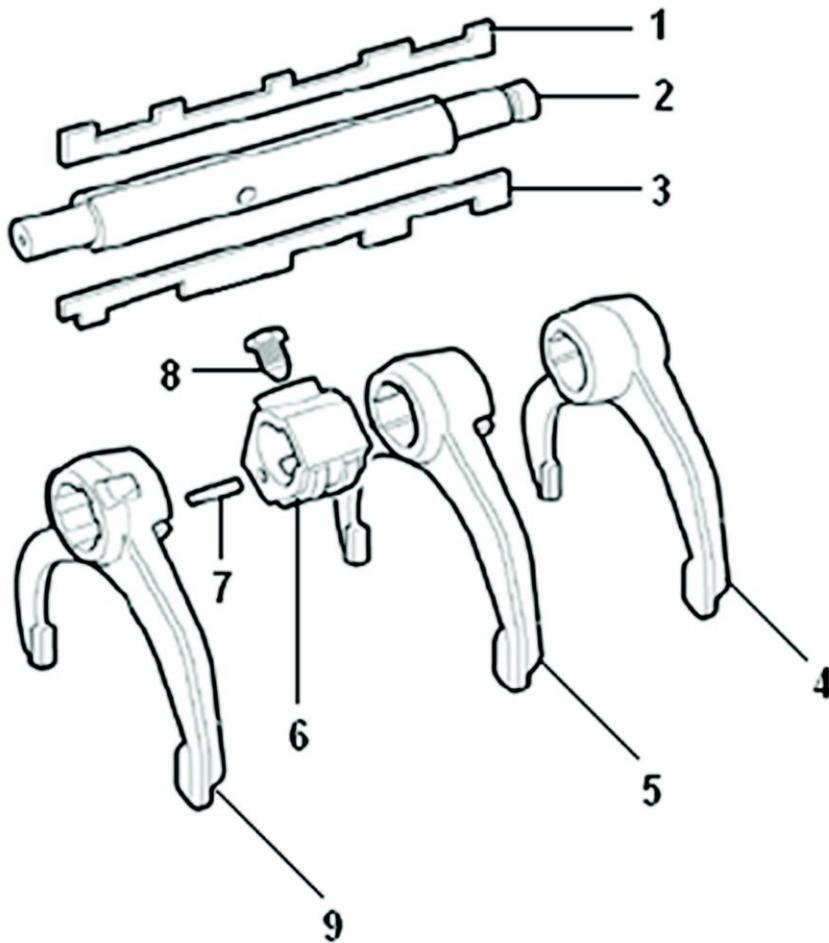

**PU0009**

**SELECTOR ASSY.**

| Item | Current Part | Description             | Replaced Part | Qty. | Notes         | Kits/Assys Where Needed |
|------|--------------|-------------------------|---------------|------|---------------|-------------------------|
| 0    | U8876833     | SELECTOR ASSY.          |               | 1    |               |                         |
| 1    | 8872731      | SELECTOR KEY            |               | 1    |               |                         |
| 2    | 8872734      | SELECTOR SHAFT          |               | 1    |               |                         |
| 3    | 8872732      | INTERLOCK KEY           |               | 1    |               |                         |
| 4    | 8872006      | FORK<br>CRAWLER/REVERSE |               | 1    |               |                         |
| 5    | 8872007      | FORK 1ST/2ND            |               | 1    |               |                         |
| 6    | 8876835      | SELECTOR BLOCK          |               | 1    |               |                         |
| 7    | X8870277     | DOWEL                   |               | 1    |               |                         |
| 8    | 8873691      | SCREW                   |               | 1    | M10X23 HEX HD |                         |
| 9    | 8872634      | FORK 3RD/4TH            |               | 1    |               |                         |



Copyright Eaton Corporation, 2009.  
Eaton hereby grants their customers,  
vendors, or distributors permission to  
freely copy, reproduce and/or distribute  
this document in printed format. It may  
be copied only in its entirety without  
any changes or modifications. THIS  
INFORMATION IS NOT INTENDED FOR  
SALE OR RESALE, AND THIS NOTICE  
MUST REMAIN ON ALL COPIES.

