



Powering Business Worldwide

Illustrated Parts List

Y06261

November 2015

Contents

How To Use The Illustrated Parts List	3
CLUTCH HOUSING ASSY.	4
FRONT BEARING COVER ASSY.	6
FRONT CASE ASSY.....	7
INPUT SHAFT ASSEMBLY	9
INTERMEDIATE CASE ASSY.	10
LAYSHAFT ASSY.	12
LRC ASSEMBLY	14
MAINSHAFT ASSY.....	16
PLANET GEAR SPINDLE ASSY	19
RANGE ASSY.....	20
RANGE CONTROL ASSY.....	22
REAR CASE ASSY.	24
REVERSE IDLER SHAFT.....	27
SELECTOR ASSY.	28

How To Use The Illustrated Parts List

The information contained in this document is subject to frequent updates. Therefore, for the latest information available, please visit the interactive Electronic Parts Catalog at <http://www.eaton.com/EatonCom/TruckEurope/TruckEurope/index.htm>

Model Designation and Nomenclature

- For information regarding Model Designation and Nomenclature, visit <http://www.eaton.com/EatonCom/TruckEurope/TruckEurope/index.htm>

Kits and Assemblies (K/A's)

- Kits or Assemblies contain groups of individual or assembled parts specially developed for optimal replacement during repair.
- Kits and Assemblies are shown with applicable parts groupings in the parts listings.

Identifying Kits and Assemblies

A- Part numbers beginning with the letter 'A' are pre-assembled Production Assemblies

K- Part numbers beginning with the letter 'K' are kits that are not assembled

T - Part numbers beginning with the letter 'T' are kits that are not assembled

S- Part numbers beginning with the letter 'S' are pre-assembled Service Assemblies

- Note: Some Production Assemblies do not begin with a letter prefix (Midrange only).

Illustrations

- Illustrations show parts in assembly groups.
- Item numbers on illustrations correspond with parts listings adjacent to the illustration.(on the same or adjacent page)
- Notes are included on illustrations where additional information is needed.

Parts Listing

Parts listings are defined by parts groupings and are broken down by service assemblies. Parts listings identify a part for servicing with the following categories

- **ITEM** - Number corresponds to number on illustration for part identification.
- **CURRENT PART** - part number of the part available for service.
- **DESCRIPTION** - part name or description.
- **REPLACED PART** - number of replaced part.
- **QTY** - Quantity required for assembly.
- **NOTES** - unique characteristics or requirements.
- **KITS / ASSYS WHERE NEEDED** - kits or assemblies that contain the part.

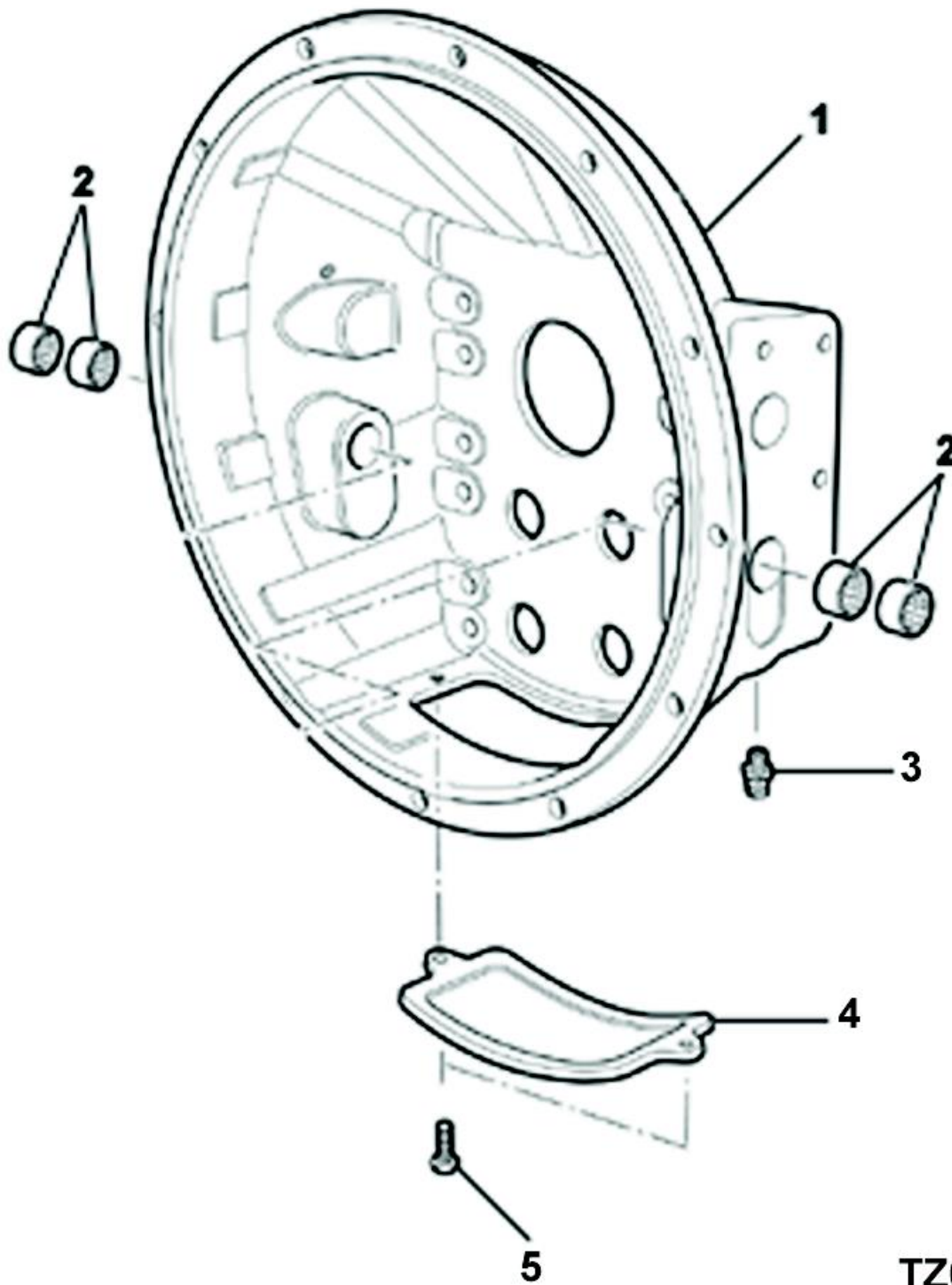

TZ0048

CLUTCH HOUSING ASSY.

Item	Current Part	Description	Replaced Part	Qty.	Notes	Kits/Assys Where Needed
0	U8877110	CLUTCH HOUSING ASSEMBLY		1	COMPRISES ITEMS 1 AND 2	

Item	Current Part	Description	Replaced Part	Qty.	Notes	Kits/Assys Where Needed
1	8877109	CLUTCH HOUSING		1		
2	12815	BUSHING		4		
3	X11476	GREASE NIPPLE		3		
4	8875171	COVER PLATE		1		
5	GMX-8-1088	SCREW		2	M12X25 HEX FLG HD	

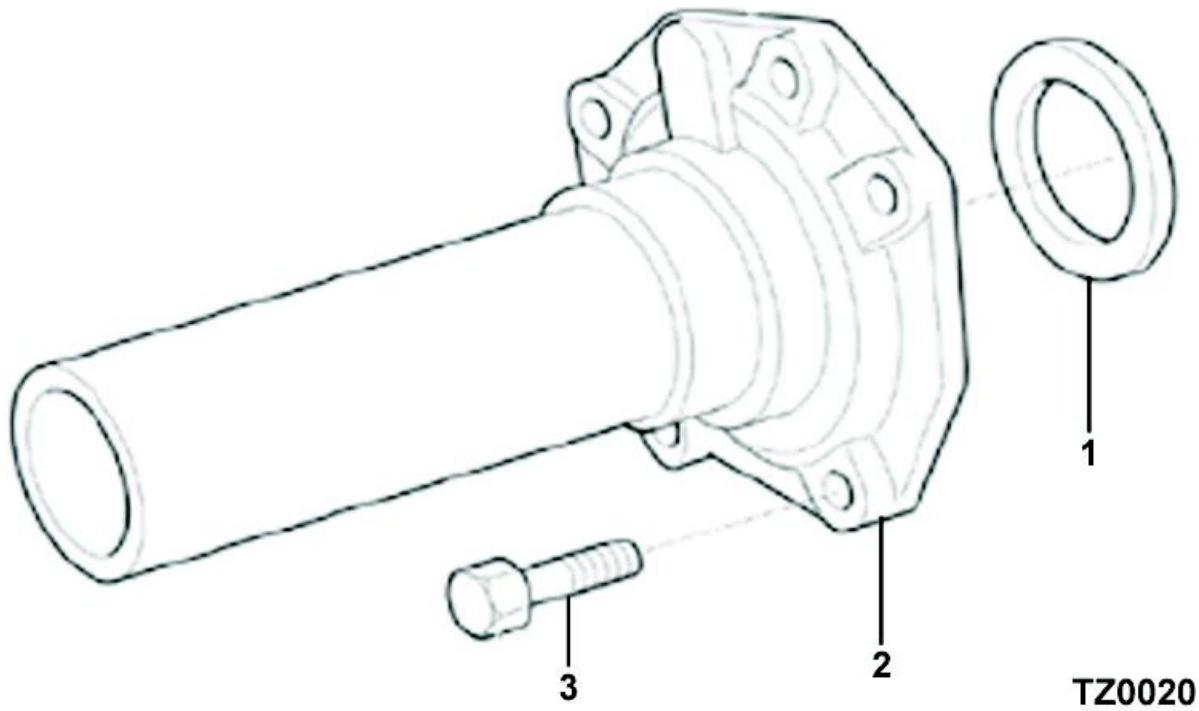

FRONT BEARING COVER ASSY.

Item	Current Part	Description	Replaced Part	Qty.	Notes	Kits/Assys Where Needed
0	U8872616	FRONT COVER ASSEMBLY		1	COMPRISES ITEMS 1 AND 2	
1	X8870760	OIL SEAL		1		
2	8872600	FRONT BEARING COVER		1		
3	GMX-8-1089	SCREW		5	M10X25 HEX FLG HD	

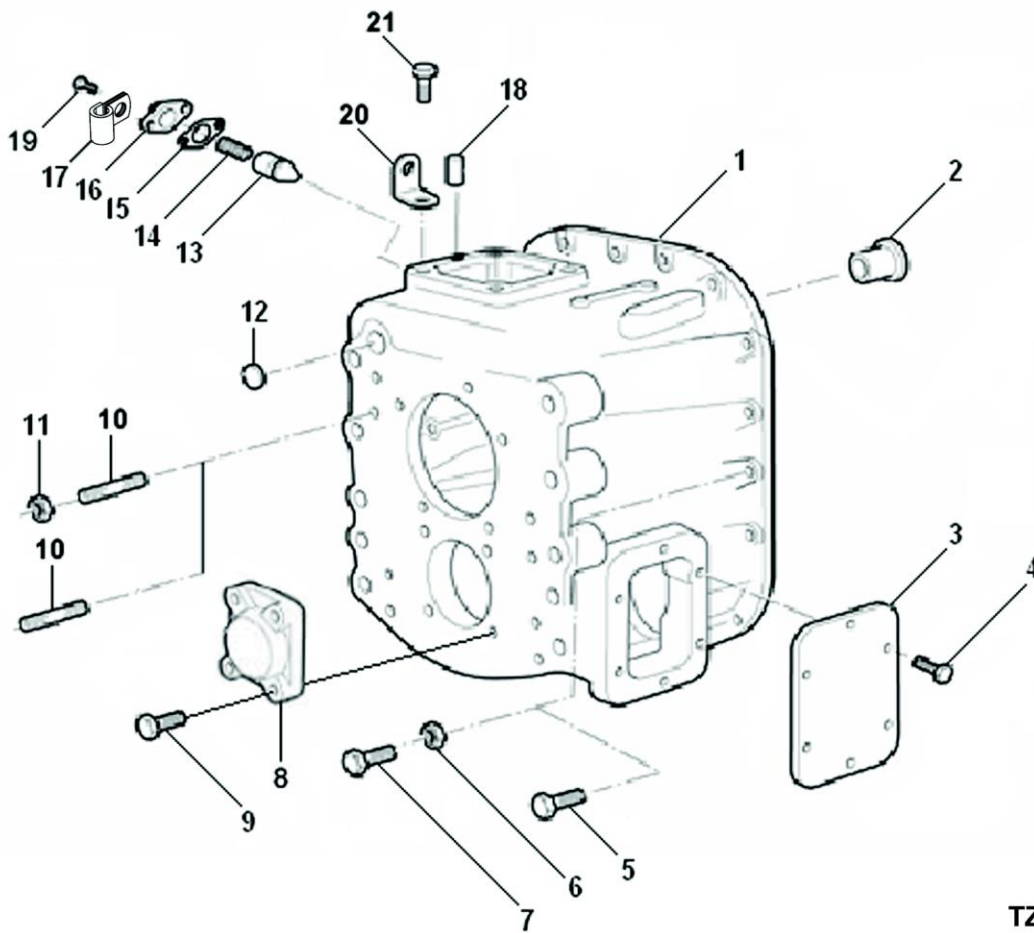

TZ0693

FRONT CASE ASSY.

Item	Current Part	Description	Replaced Part	Qty.	Notes	Kits/Assys Where Needed
0	U8882043	FRONT CASE ASSY.		1	COMPRISES ITEMS 1, 2, 10-12 AND 22	
1	8881835	FRONT CASING		1		
2	8883756	BUSH	8882415	1	FOR MAIN SELECTOR SHAFT	
3	8881616	PTO PROVISION COVER		1		
4	GMX-8-1088	SCREW		6	M12X25 HEX FLG HD	
5	GMX-8-1079	BOLT		4	M10X40	
6	GMX-9-1005	NUT		14	M10X1.5	
7	GMX-8-1080	BOLT		14	M10X58	
8	GX8880554	BEARING COVER LAYSHAFT		1		

Item	Current Part	Description	Replaced Part	Qty.	Notes	Kits/Assys Where Needed
9	GMX-8-1240	SCREW		4	M12X25 HEX FLG HD	
10	GX8873931	STUD		10	M12X45 LONG	
10	GX8874699	STUD		2	M12X65 LONG	
11	GMX-9-1204	NUT		12	M12	
12	GX8870278	CUP PLUG		1		
13	8873654	PLUNGER-NEUTRAL		1		
14	8874897	SPRING COMPRESSION		1		
15	8870590	GASKET		1		
16	GX8870259	DETENT COVER		1		
17	8876407	PIPE CLIP	GX8880183	1		
18	X8870542	DOWEL		2	8,0 DIA X 16	
19	GMX-8-0819	SCREW	GMX-8-0801	2	M8 X 16	
20	GX8879212	LIFTING EYE		1	15 MM	
21	GMX-8-1091	SCREW		4	M10X30 HEX FLG HD	

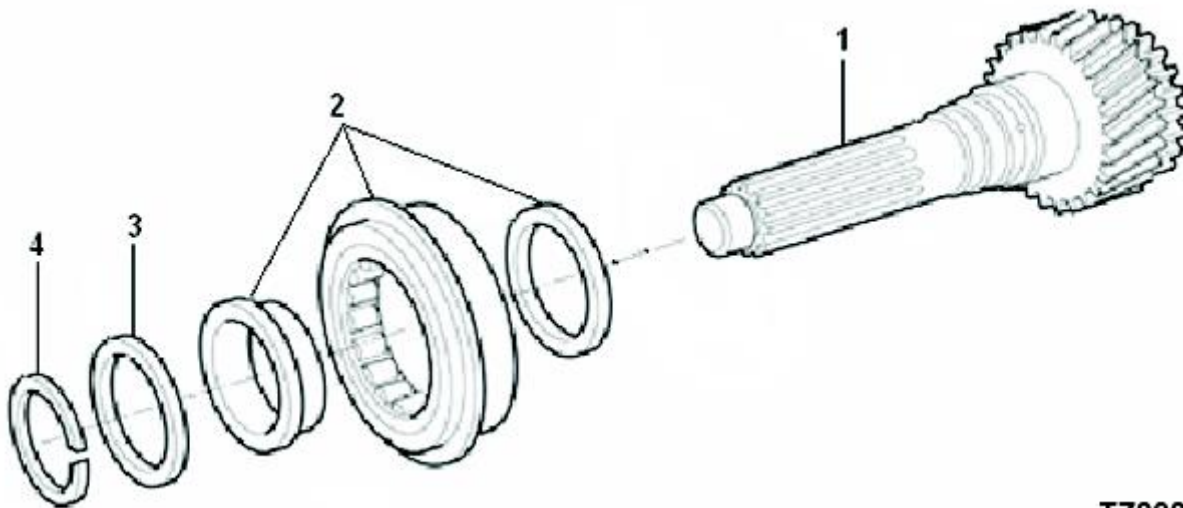

TZ0003

INPUT SHAFT ASSEMBLY

Item	Current Part	Description	Replaced Part	Qty.	Notes	Kits/Assys Where Needed
0	U8880155	INPUT SHAFT ASSEMBLY		1	COMPRISES ITEMS 1-4	
1	8877825	INPUT SHAFT		1		
2	X8872593	INPUT SHAFT BEARING		1		
3	8877692	SPACER - GRADED 3.10		1	PACK: U8877691	
3	8877693	SPACER - GRADED 3.15		1	PACK: U8877691	
3	8877694	SPACER - GRADED 3.20		1	PACK: U8877691	
3	8877695	SPACER - GRADED 3.25		1	PACK: U8877691	
3	8877696	SPACER - GRADED 3.30		1	PACK: U8877691	
3	8877697	SPACER - GRADED 3.35		1	PACK: U8877691	
3	8877698	SPACER - GRADED 3.40		1	PACK: U8877691	
3	8877699	SPACER - GRADED 3.45		1	PACK: U8877691	
3	8877700	SPACER - GRADED 3.50		1	PACK: U8877691	
3	U8877691	SPACER - GRADED PACK		1		
4	X8877706	CIRCLIP		1		

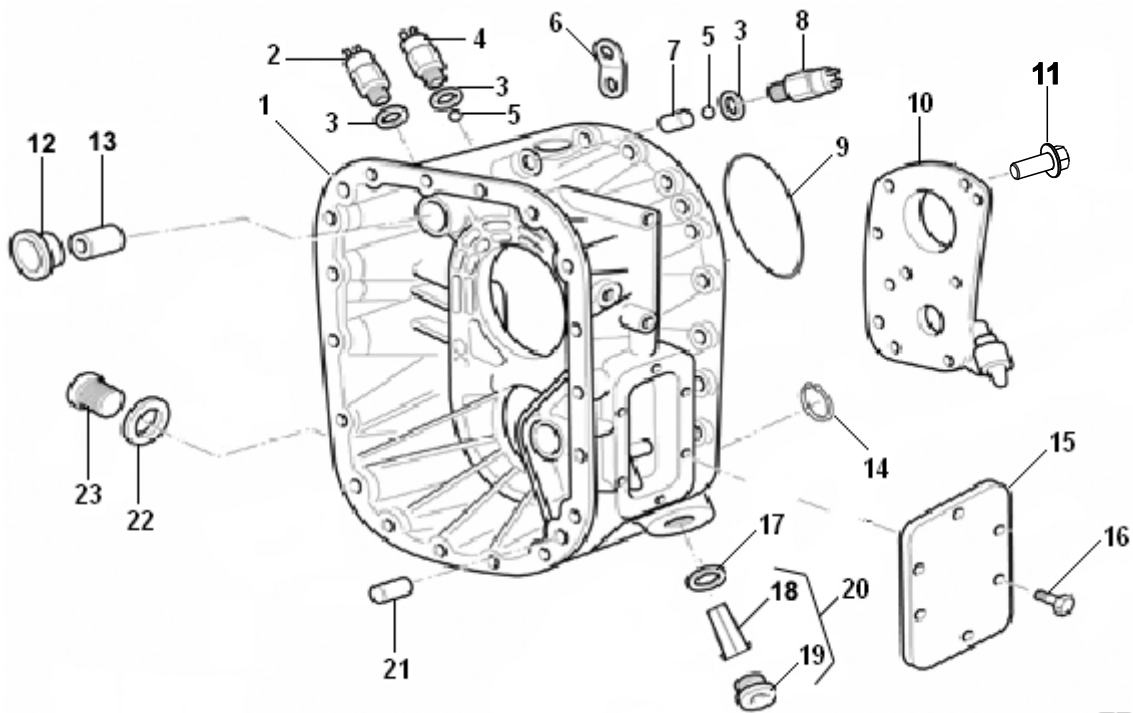

TZ0607

INTERMEDIATE CASE ASSY.

Item	Current Part	Description	Replaced Part	Qty.	Notes	Kits/Assys Where Needed
0	U8876645	INTERMEDIATE CASE ASSY		1		
1	8876644	INTERMEDIATE CASE		1		
2	GX2771532	SWITCH REVERSE / RANGE		1		
3	5568510	O-RING		3		
4	8880315	NEUTRAL SWITCH		1		
5	X8870711	BALL		2	DIA.14	
6	GX8879211	LIFTING EYE		1		
7	8875267	PIN INTERLOCK		1		
8	GX2771532	SWITCH REVERSE / RANGE		1		
9	X8881475	O-RING		1	(109,5X3,0)	
10	U8883824	OIL PUMP	GU8875469	1		
11	GMX-8-1089	SCREW		8	M10X25 HEX FLG HD	
12	8883756	BUSH	8882415	1	FOR MAIN SELECTOR SHAFT	
13	X8871377	BUSH		1		

Item	Current Part	Description	Replaced Part	Qty.	Notes	Kits/Assys Where Needed
14	X8881424	CIRCLIP		1		
15	8881616	PTO PROVISION COVER		1		
16	GMX-8-1088	SCREW		6	M12X25 HEX FLG HD	
17	X8880469	WASHER-OIL STRAINER / DRAIN		1		
18	8876351	STRAINER-OIL		1		
19	GX8876352	PLUG OIL STRAINER		1		
20	GU8876353	OIL FILTER		1		
21	X8870543	DOWEL		2	16,0 DI X 30,5	
22	X8880519	WASHER-FILL/DRAIN FL		1		
23	GX8874942	OIL FILLER PLUG		1		

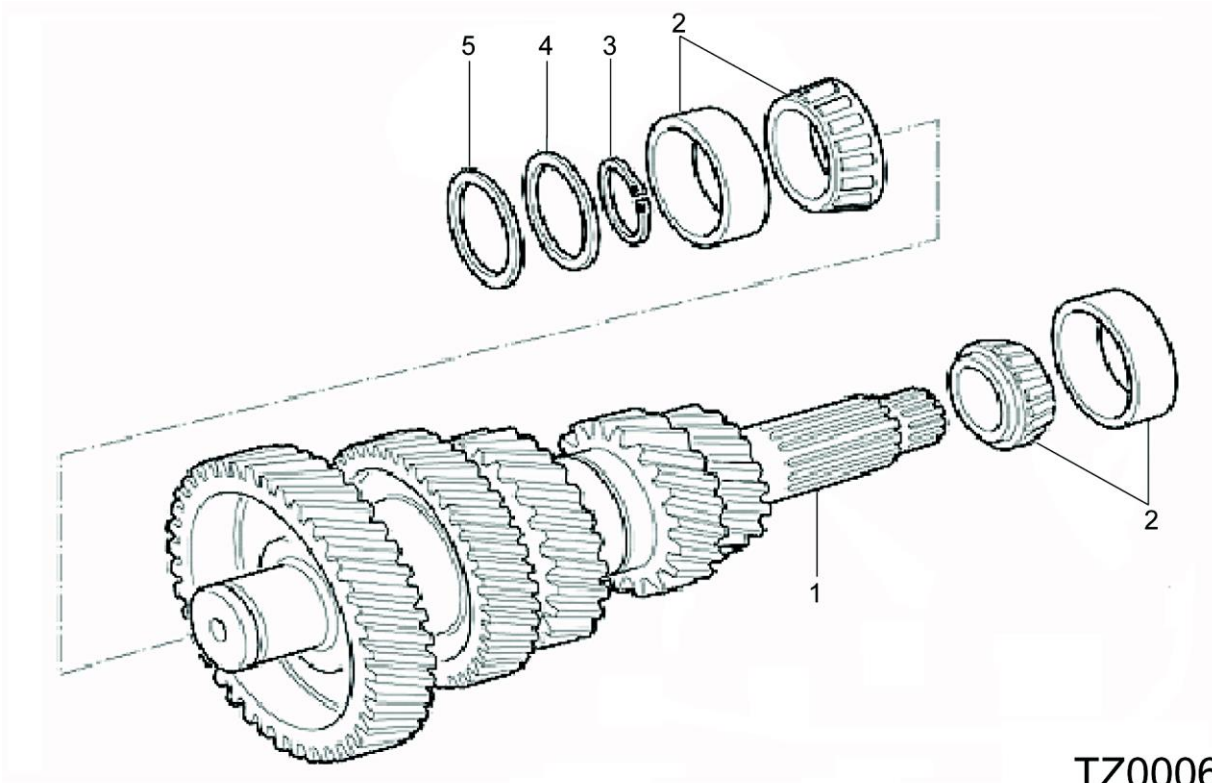

TZ0006

LAYSHAFT ASSY.

Item	Current Part	Description	Replaced Part	Qty.	Notes	Kits/Assys Where Needed
1	U8880743	LAYSHAFT ASSEMBLY		1		
2	X8875587	BEARING ASSEMBLY		2		
3	U8877534	CIRCLIP GRADED PACK		1		
3	X8870370	GR.C/CLIP 40 DIA. X 2.12 MM		1	PACK: U8877534	
3	X8870371	GR.C/CLIP 40 DIA. X 2.07 MM		1	PACK: U8877534	
3	X8870372	GR.C/CLIP 40 DIA X 2.02 MM		1	PACK: U8877534	
3	X8871536	GR.C/CLIP 40 DIA. X 1.97 MM		1		
3	X8871537	GR.C/CLIP 40 DIA. X 1.92 MM		1		
3	X8871538	GR.C/CLIP 40 DIA. X 1.87 MM		1		
3	X8871539	GR.C/CLIP 40 DIA. X 1.82 MM		1		
3	X8871540	GR.C/CLIP 40 DIA. X 1.77 MM		1		

Item	Current Part	Description	Replaced Part	Qty.	Notes	Kits/Assys Where Needed
4	F88891	SHIM		1	S=0,051	
4	F88892	SHIM		1	S=0,127	
4	F88893	SHIM		1	S=0,254	
4	F88894	SHIM		1	S=0,508	
4	U8877535	SHIM PACK		1		
4	X8882272	SHIM		1	S=1,200	
5	8875879	SPACER		1		

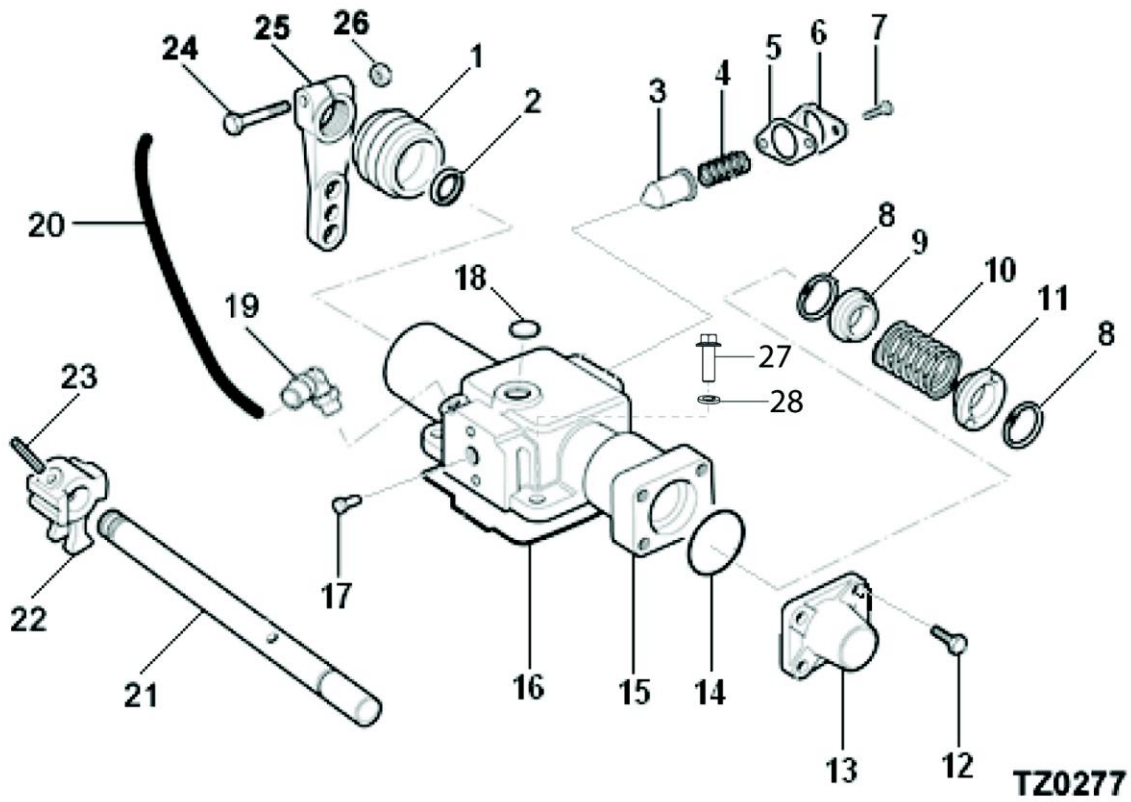

LRC ASSEMBLY

Item	Current Part	Description	Replaced Part	Qty.	Notes	Kits/Assys Where Needed
0	U8881053	LRC ASSY. RHV		1	COMPRISES ITEMS 1-3, 5-9, 11, 13, 14, 18 AND 23	
1	X8875259	BOOT		1		
2	X8881481	OIL SEAL		1		
3	8875415	PLUNGER - DETENT		1		
4	8871098	SPRING COMPRESSION		1		
5	GX8870259	DETENT COVER		1		
6	8870590	GASKET		1		
7	GMX-8-0848	SCREW		2		
8	X8874450	CIRCLIP		2	25.DIA	
9	8876566	SPRING RETAINER-BOOSTER		1		
10	8871395	SPRING COMPRESSION		1		
11	8876567	SPRING RETAINER-BIAS		1		
12	GMX-8-	SCREW		4		

Item	Current Part	Description	Replaced Part	Qty.	Notes	Kits/Assys Where Needed
	0847					
13	8880477	END CAP		1		
14	X8880639	O-RING		1		
15	U8880940	LRC SUB ASSY.		1		
16	8880638	SEAL		1		
17	8871375	SWITCH ACTIVATOR PIN		1		
18	GX8871486	EXPANSION PLUG		1		
19	X8881546	SWIVEL ELBOW ADAPTOR 90 DEG	X8880846	1		
20	X8881590	NYLON TUBE	X8881545	1	4MM, LENGTH 0.25M	
21	8874760	SHIFT ROD		1		
22	8877656	LEVER INNER STRIKING		1		
23	X8871378	DOWEL		1	10,0 DIA X 44	
24	GX8876051	OUTER LEVER				
	1					
25	GMX-8- 1007	BOLT		1	M10X50	
26	GMX-9- 1005	NUT		1	M10X1.5	
27	GMX-8- 1091	SCREW		4	M10X30 HEX FLG HD	
28	GMX-3- 1001	SPRING WASHER		4	M10	

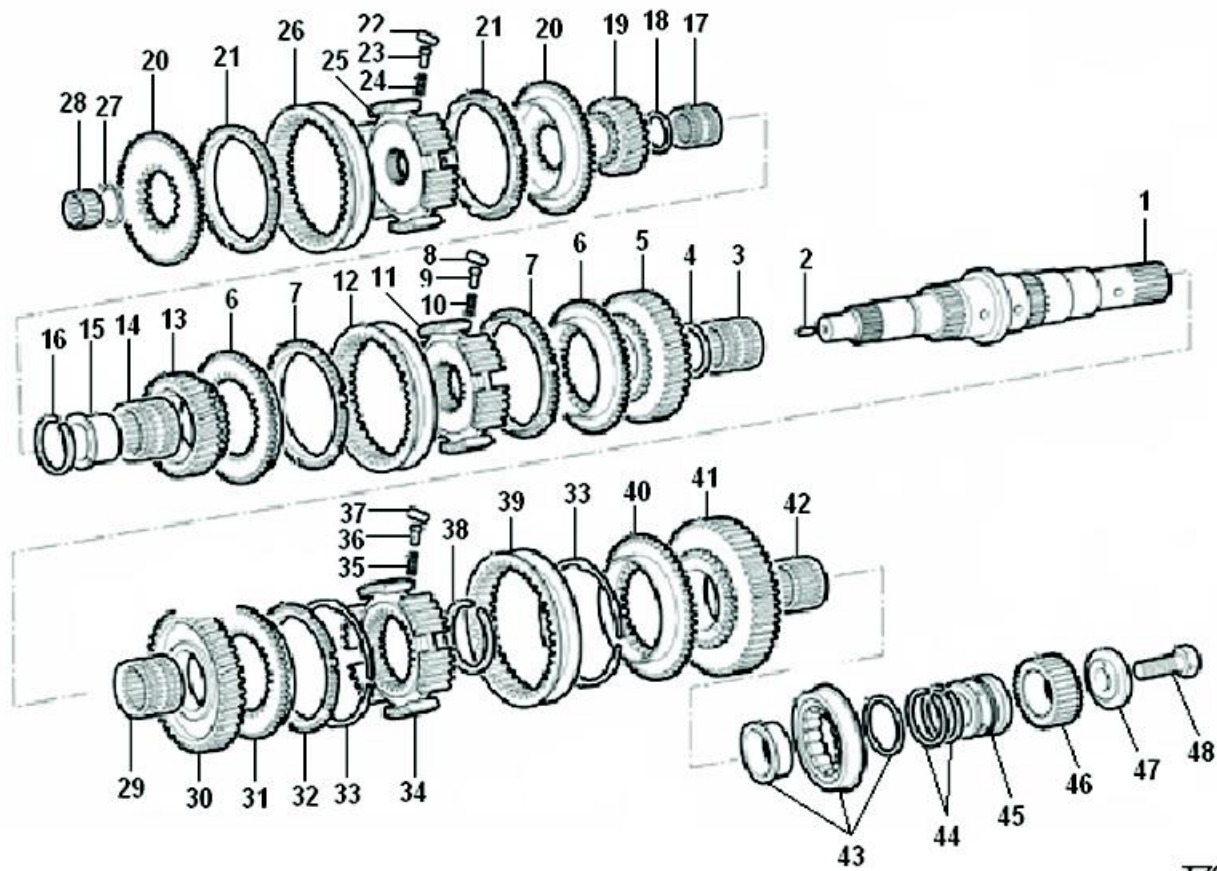

TZ0005

MAINSHAFT ASSY.

Item	Current Part	Description	Replaced Part	Qty.	Notes	Kits/Assys Where Needed
0	U8882818	MAINSHAFT ASSY.		1	COMPRISES ITEMS 1-42	
1	U8875877	MAINSHAFT SUB ASSY.		1		
2	X14851	DOWEL		1	5/16 DI X 1.50	
3	X8872233	NEEDLE ROLLER BRG. ASSY		1		
4	8872589	GEAR SPACER 1ST		1		
5	8876948	GEAR MAINSHAFT 1ST		1		
6	8877321	SYNCHRO FLANGE 1/2/3/4		2		
7	8883044	RING SYNCHRO 1ST/2ND	8882682	2		
8	X8870356	ROLLER		3		
9	8870352	PLUNGER		3		
10	8870444	SPRING COMPRESSION		3		
11	8875571	HUB-FIXED, 1ST/2ND		1		

Item	Current Part	Description	Replaced Part	Qty.	Notes	Kits/Assys Where Needed
12	8880460	SLIDING SLEEVE		1		
13	8872582	GEAR MAINSHAFT 2ND		1		
14	X8872233	NEEDLE ROLLER BRG. ASSY		1		
15	8882868	SLEEVE MAINSHAFT BEARING		1		
16	U8882558	GRADED CIRCLIP PACK		1		
16	X8870534	GR.CIRCLIP 46 DIA. X 2.10 MM		1	PACK: U8882558	
16	X8870535	GR.CIRCLIP 46 DIA. X 2.05 MM		1	PACK: U8882558	
16	X8870536	GR.CIRCLIP 46 DIA. X 2.00 MM		1	PACK: U8882558	
16	X8883040	CIRCLIP GRADED 46 DIA X2.15 MM		1	PACK: U8882558	
16	X8883041	CIRCLIP GRADED 46 DIA X 2.20 MM		1	PACK: U8882558	
17	X8870180	NEEDLE BEARING		1		
18	8872588	GEAR SPACER 4TH		1		
19	8880740	GEAR MAINSHAFT 3RD		1		
20	8877321	SYNCHRO FLANGE 1/2/3/4		2		
21	8883044	RING SYNCHRO 1ST/2ND	8882682	2		
22	X8870356	ROLLER		3		
23	8870352	PLUNGER		3		
24	8870444	SPRING COMPRESSION		3		
25	8875554	FIXED HUB 3RD/4TH		1		
26	8880460	SLIDING SLEEVE		1		
27	U8877531	GRADED CIRCLIP PACK		1		
27	X8870370	GR.C/CLIP 40 DIA. X 2.12 MM		1		
27	X8870371	GR.C/CLIP 40 DIA. X 2.07 MM		1		
27	X8870372	GR.C/CLIP 40 DIA X 2.02 MM		1		
28	X8870305	NEEDLE BRG.ROLLER ASSY		1		
29	X8872233	NEEDLE ROLLER BRG. ASSY		1		

Item	Current Part	Description	Replaced Part	Qty.	Notes	Kits/Assys Where Needed
30	8876477	GEAR MAINSHAFT CRAWLER	8873894	1		
31	8877316	SYNCHRO FLANGE		1		
32	8877313	SYNCHRO RING		1		
33	X8873994	CIRCLIP SYNCHRO. ASSY.		1		
34	8875604	FIXED HUB REVERSE/CRAWLER		1		
35	8870444	SPRING COMPRESSION		3		
36	8870352	PLUNGER		3		
37	X8870356	ROLLER		3		
38	U8877532	GRADED CIRCLIP PACK		1		
38	X8870378	CIRCLIP-GR.DIA.60 X 2.10 MM		1		
38	X8870379	CIRCLIP-GR.DIA.60 X 2.05 MM		1		
38	X8870380	CIRCLIP-GR.DIA.60 X 2.00 MM		1		
39	8880461	SLIDING SLEEVE		1		
40	8870415	SYNCHRO FLANGE REVERSE		1		
41	8872585	GEAR MAINSHAFT REVERSE		1		
42	X8870178	NEEDLE ROLLER BRG. ASSY		1		
43	X8877164	BEARING REAR MAINSHAFT		1		
44	X8875532	SEALING RING		2		
45	8874921	OIL MUFF		1		
46	8875585	SUN GEAR		1		
47	8880594	RETAINER		1		
48	GX8870699	SCREW		1	M16X45 HEX HD	

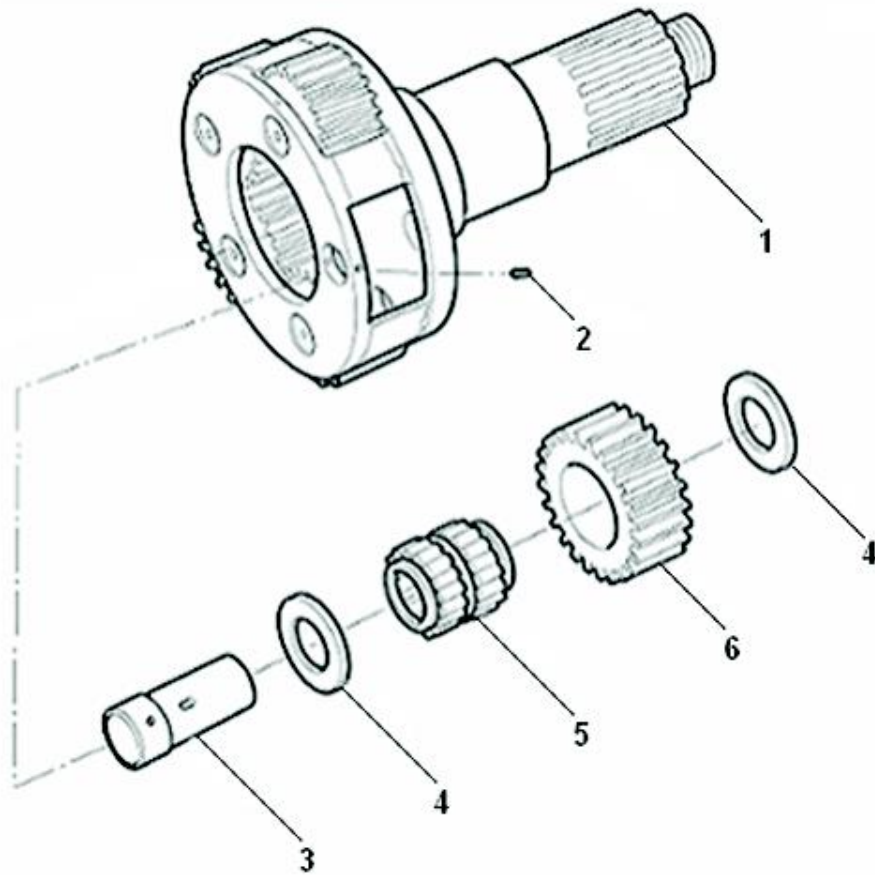

TZ0008

PLANET GEAR SPINDLE ASSY

Item	Current Part	Description	Replaced Part	Qty.	Notes	Kits/Assys Where Needed
0	U8876327	PLANET GEAR SPINDLE ASSY		1	COMPRISES ITEMS 1-6	
1	U8882491	OUTPUT SHAFT ASSY		1		
2	MX-11-0601	SCREW		5	M6 X 10 SKT HD SET	
3	8872682	SPINDLE-PLANET GEAR		5		
4	8876893	WASHER		10		
5	U8875235	NEEDLE ROLLER BRG. ASSY.		5		
6	8883395	GEAR PLANET	8875586	5		

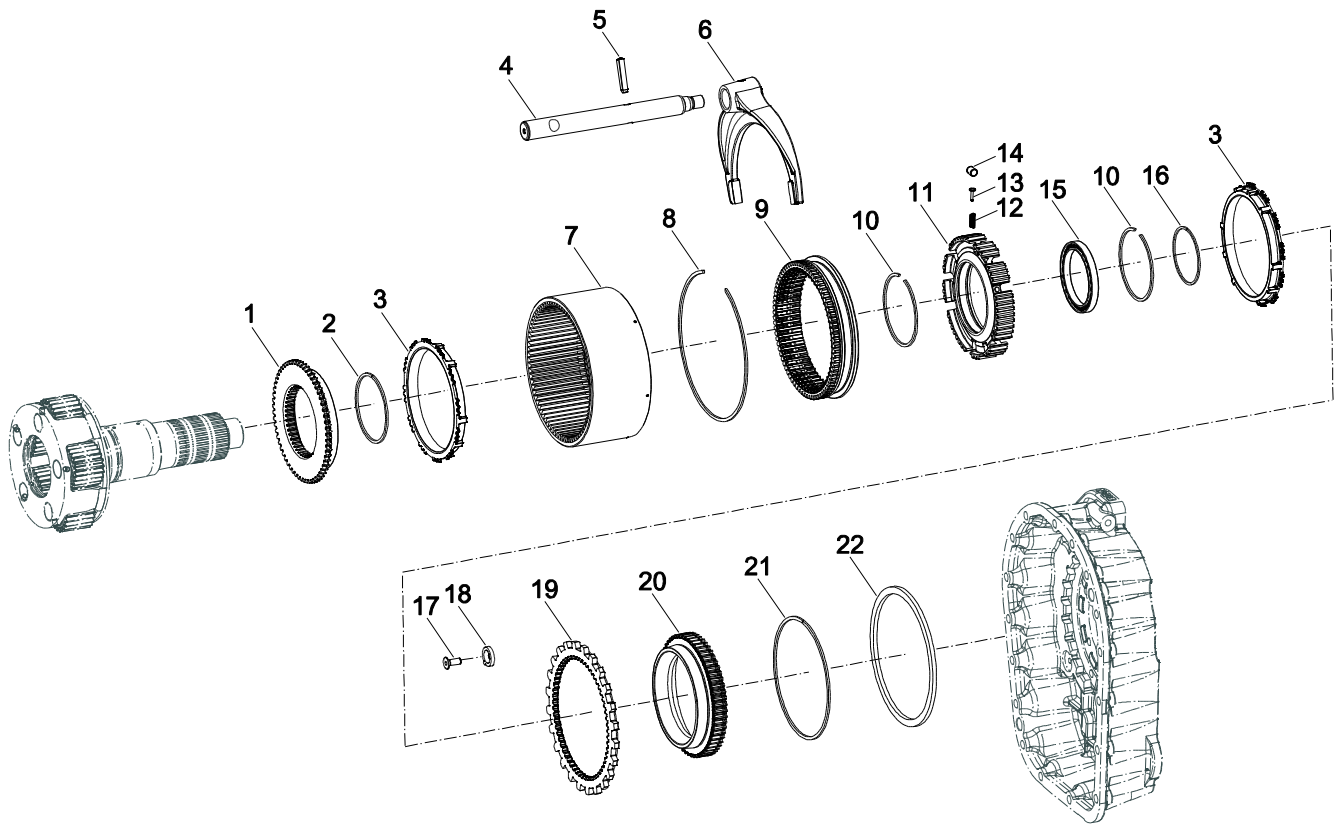

PU0146

RANGE ASSY.

Item	Current Part	Description	Replaced Part	Qty.	Notes	Kits/Assys Where Needed
1	8877323	SYNCHRO FLANGE		1		
2	X8870342	CIRCLIP		1		
3	8877442	SYNCHRO RING - RANGE		2		
4	8872626	HI-LO SHIFT ROD		1		
5	X8878665	DOWEL	X8870726	1		
6	8872737	HIGH/LOW SHIFT FORK	8872737,8883677	1		
7	8872680	ANNULUS		1		
8	X8875296	CIRCLIP		1		
9	8880522	SLIDING SLEEVE		1		
10	X8870341	CIRCLIP		1		

Item	Current Part	Description	Replaced Part	Qty.	Notes	Kits/Assys Where Needed
11	8875881	FIXED HUB		1		
12	8870444	SPRING COMPRESSION		9		
13	8870352	PLUNGER		9		
14	X8870355	ROLLER		9		
15	X8870844	BEARING		1		
16	X8870344	CIRCLIP		1		
17	GMX-8-0806	SCREW		3	M8X20	
18	8870848	RETAINER		3		
19	8875646	REACTION PLATE		1		
20	8877322	SYNCHRO FLANGE		1		
21	X8873993	CIRCLIP		1		
22	8870808	SPACER		1		

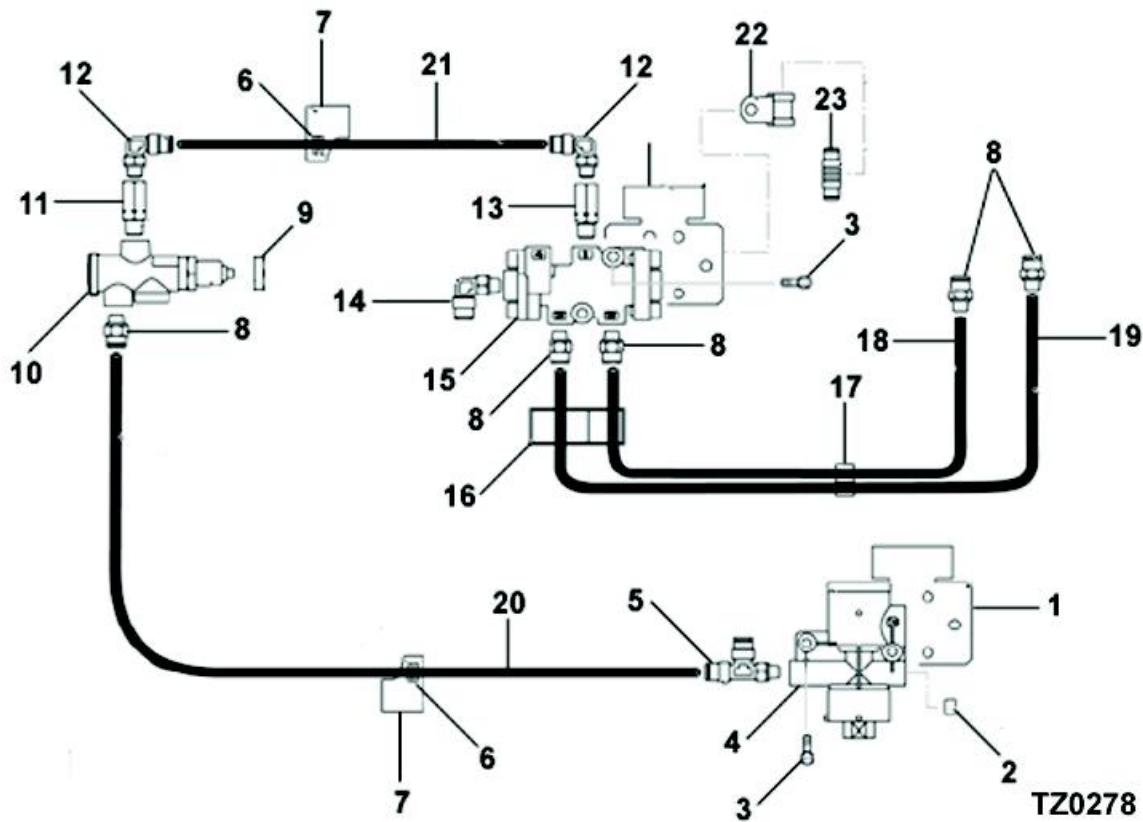

RANGE CONTROL ASSY.

Item	Current Part	Description	Replaced Part	Qty.	Notes	Kits/Assys Where Needed
0	U8881164	RANGE CONTROL ASSY.		1	COMPRISES ITEMS 1-23	
1	8880659	MOUNTING BRACKET		2		
2	GX2013517	PIPE PLUG		1	1/8	
3	X8880151	SCREW SPIRAL	GX8880151	4		
4	X8880109	FILTER REGULATOR		1		
5	U8881542	SWIVEL TEE ADAPTOR(BSP TO 6MM TUBE)		1		
6	X8882634	PIPE CLIP		1		
7	8882665	AIR PIPES		2		
8	X8881538	STRAIGHT ADAPTOR		5	6MM	
9	5568510	O-RING		1		
10	X8880054	3/2 POPPET VALVE		1		
11	X8883138	ADAPTOR G1/8		1		
12	X8880846	ELBOW ARTICULATED		2		

Item	Current Part	Description	Replaced Part	Qty.	Notes	Kits/Assys Where Needed
13	X8883139	RESTRICTOR G1/8		1		
14	X8881546	SWIVEL ELBOW ADAPTOR 90 DEG		1		
15	X8880843	4/2 AIR ACTUATING VALVE		1		
16	GX8880183	PIPE CLIP		1		
17	X8880545	PIPE CLIP - TWIN PIPE		1		
18	X8881588	MOULDED PIPE ASSY.		1	RANGE VALVE TO REAR CASE	
19	X8881587	MOULDED PIPE ASSY.		1	RANGE VALVE TO CYLINDER	
20	U8880728	MOULDED PIPE ASSY.		1	REGULATOR TO POPPET VALVE	
21	X8881545	NYLON TUBE 6 MM		1		
22	X8880637	PIPE CLIP		1	10 MM	
23	X8880636	STRAIGHT ADAPTOR4 MM TUBE		1		

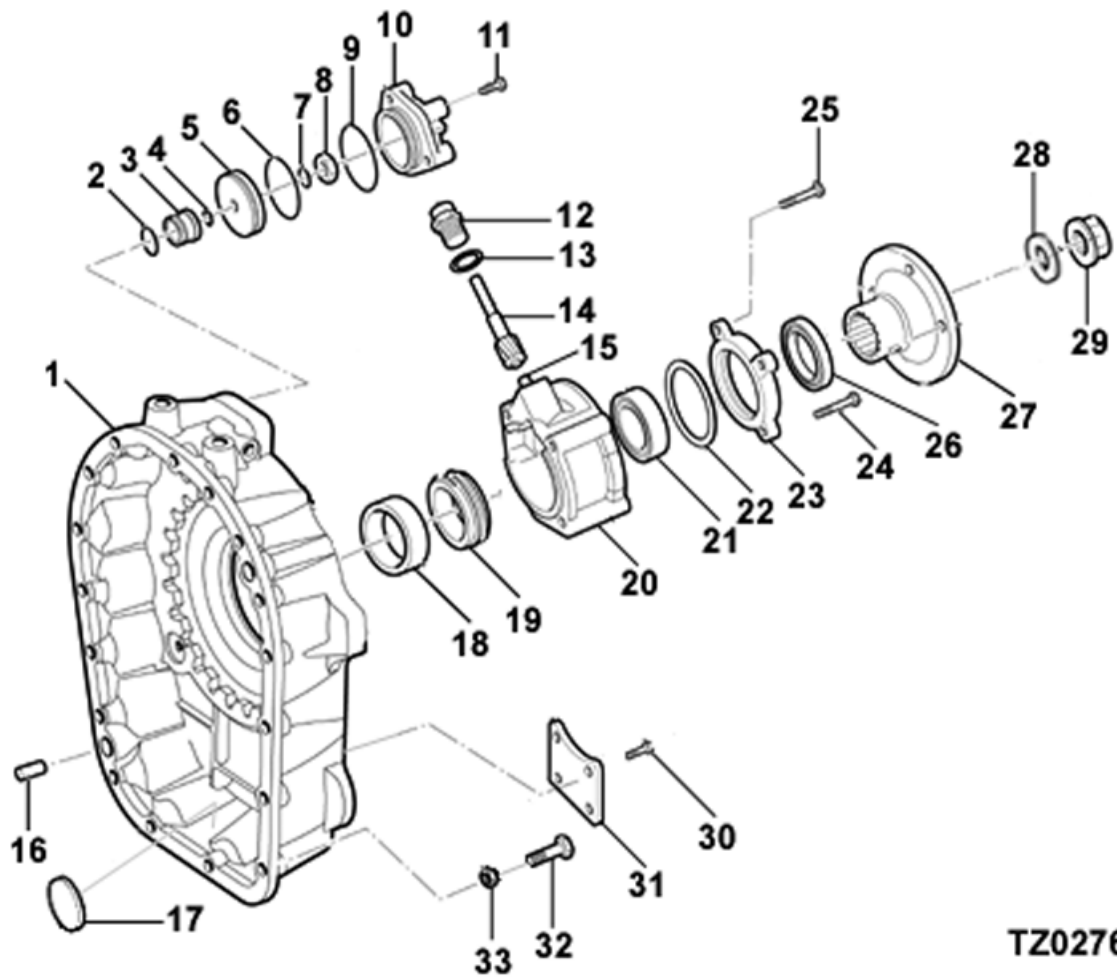

TZ0276

REAR CASE ASSY.

Item	Current Part	Description	Replaced Part	Qty.	Notes	Kits/Assys Where Needed
0	U8880532	REAR CASE ASSY.		1	COMPRISES ITEMS 1-11, 16 AND 17	
1	8874367	REAR CASING		1		
2	X8875292	O-RING		1		
3	8878240	BUSH	8875293	1		
4	X8871258	O-RING		1	DIA.24,5	
5	8875179	PISTON RANGE CYLINDER		1		
6	14344	PISTON O RING		1		
7	14345	PISTON O RING		1		
8	GMX-9-1602	NUT		1	M16	
9	X8873008	O-RING		1		

Item	Current Part	Description	Replaced Part	Qty.	Notes	Kits/Assys Where Needed
10	8875430	CYLINDER-RANGE		1		
11	GMX-8-1094	BOLT		3	M10X55 HEX FLG HD	
12	8873787	ADAPTOR		1		
13	X8880471	WASHER		1		
14	8874006	SPEEDO PINION		1		
15	7992	BUSH		1		
16	X8870543	DOWEL		2	16,0 DI X 30,5	
17	14373	DISC MAGNET		1		
18	8876319	SPACER TACHO		1		
19	8876084	GEAR SPEEDO DRIVE 6TH		1		
20	8880272	SPEEDO HOUSING		1		
21	X8872721	BEARING		1		
22	8880306	SHIM REAR BEARING		1	PACK: U8880276	
22	8880307	SHIM-REAR BEARING		1	PACK: U8880276	
22	8880308	SHIM REAR BEARING		1	PACK: U8880276	
22	U8880276	SHIM PACK		1		
23	8871992	REAR COVER		1		
24	GMX-8-1095	BOLT		3	M10X95 HEX FLG HD	
25	GMX-8-1096	BOLT		1	M10X95 HEX FLG HD	
26	X8872722	OIL SEAL		1		
27	8874353	SPEEDOMETER PINION		1		
28	8883649	THRUST WASHER	8874004	1		
29	GX8870564	MAINSHAFT NUT		1	M33	
30	GMX-8-1240	SCREW		4	M12X25 HEX FLG HD	
31	GX8873917	LAYSHAFT REAR COVER		1		
32	GMX-8-10111	BOLT		3	M10X65 HEX FLG HD	
32	GMX-8-1080	BOLT		14	M10X58	

Item	Current Part	Description	Replaced Part	Qty.	Notes	Kits/Assys Where Needed
32	GMX-8-1094	BOLT		1	M10X55 HEX FLG HD	
33	GMX-9-1005	NUT		17	M10X1.5	

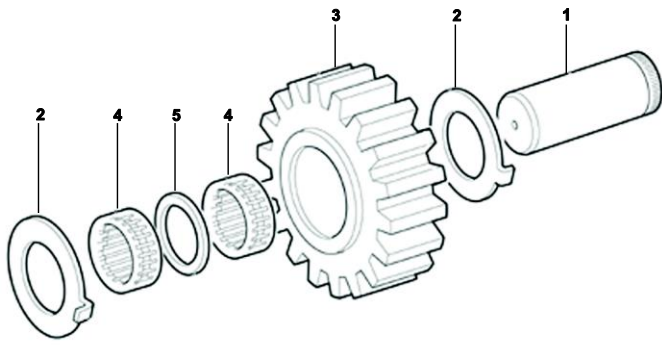

TZ0007

REVERSE IDLER SHAFT

Item	Current Part	Description	Replaced Part	Qty.	Notes	Kits/Assys Where Needed
1	8883246	REVERSE IDLER SHAFT		1		
2	8870343	THRUST WASHER		2		
3	8872173	GEAR IDLER REVERSE		1		
4	X8872478	NEEDLE ROLLER BRG		2		
5	8872479	SPACER		1		

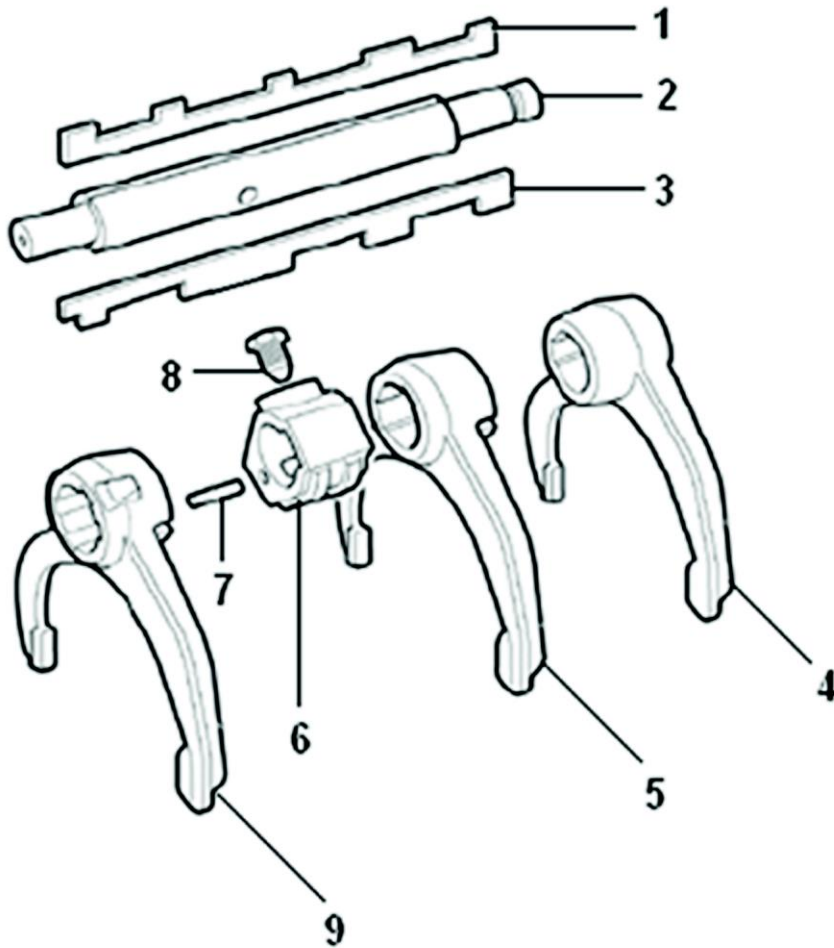

PU0009

SELECTOR ASSY.

Item	Current Part	Description	Replaced Part	Qty.	Notes	Kits/Assys Where Needed
0	U8875914	SELECTOR BLOCK		1	INCLUDES 8874754 & X8870277	
0	U8875941	SELECTOR ASSY.		1	COMPRISES ITEMS 1-9	
1	8872328	SELECTOR KEY		1		
2	8882443	SELECTOR SHAFT	8875827	1		
3	8880759	INTERLOCK KEY	8872327	1		
4	8875499	FORK CRAWLER/REVERSE		1		
5	8880760	FORK 1ST/2ND		1		
6	8874754	SELECTOR BLOCK		1		
7	X8870277	DOWEL		1		
8	8873691	SCREW		1	M10X23 HEX HD	
9	8875494	FORK 3RD/4TH		1		

Copyright Eaton Corporation, 2009.
Eaton hereby grants their customers,
vendors, or distributors permission to
freely copy, reproduce and/or distribute
this document in printed format. It may
be copied only in its entirety without
any changes or modifications. THIS
INFORMATION IS NOT INTENDED FOR
SALE OR RESALE, AND THIS NOTICE
MUST REMAIN ON ALL COPIES.

