



Powering Business Worldwide

Illustrated Parts List

Y08368

November 2015

Contents

How To Use The Illustrated Parts List	3
FRONT BEARING COVER ASSY.	4
FRONT CASE ASSY.....	5
INPUT SHAFT ASSY.....	7
INTERMEDIATE CASE ASSY.....	8
LAYSHAFT ASSY.	10
MAINSHAFT ASSY.....	12
PLANET GEAR SPINDLE ASSY.	15
PPA UNIT 9 SPEED.....	16
RANGE ASSY.....	17
RANGE CONTROL ASSY.....	19
REAR CASE ASSY.	20
REVERSE IDLER ASSY.....	22
SELECTOR ASSY.	23

How To Use The Illustrated Parts List

The information contained in this document is subject to frequent updates. Therefore, for the latest information available, please visit the interactive Electronic Parts Catalog at <http://www.eaton.com/EatonCom/TruckEurope/TruckEurope/index.htm>

Model Designation and Nomenclature

- For information regarding Model Designation and Nomenclature, visit <http://www.eaton.com/EatonCom/TruckEurope/TruckEurope/index.htm>

Kits and Assemblies (K/A's)

- Kits or Assemblies contain groups of individual or assembled parts specially developed for optimal replacement during repair.
- Kits and Assemblies are shown with applicable parts groupings in the parts listings.

Identifying Kits and Assemblies

A- Part numbers beginning with the letter 'A' are pre-assembled Production Assemblies

K- Part numbers beginning with the letter 'K' are kits that are not assembled

T - Part numbers beginning with the letter 'T' are kits that are not assembled

S- Part numbers beginning with the letter 'S' are pre-assembled Service Assemblies

- Note: Some Production Assemblies do not begin with a letter prefix (Midrange only).

Illustrations

- Illustrations show parts in assembly groups.
- Item numbers on illustrations correspond with parts listings adjacent to the illustration.(on the same or adjacent page)
- Notes are included on illustrations where additional information is needed.

Parts Listing

Parts listings are defined by parts groupings and are broken down by service assemblies. Parts listings identify a part for servicing with the following categories

- **ITEM** - Number corresponds to number on illustration for part identification.
- **CURRENT PART** - part number of the part available for service.
- **DESCRIPTION** - part name or description.
- **REPLACED PART** - number of replaced part.
- **QTY** - Quantity required for assembly.
- **NOTES** - unique characteristics or requirements.
- **KITS / ASSYS WHERE NEEDED** - kits or assemblies that contain the part.

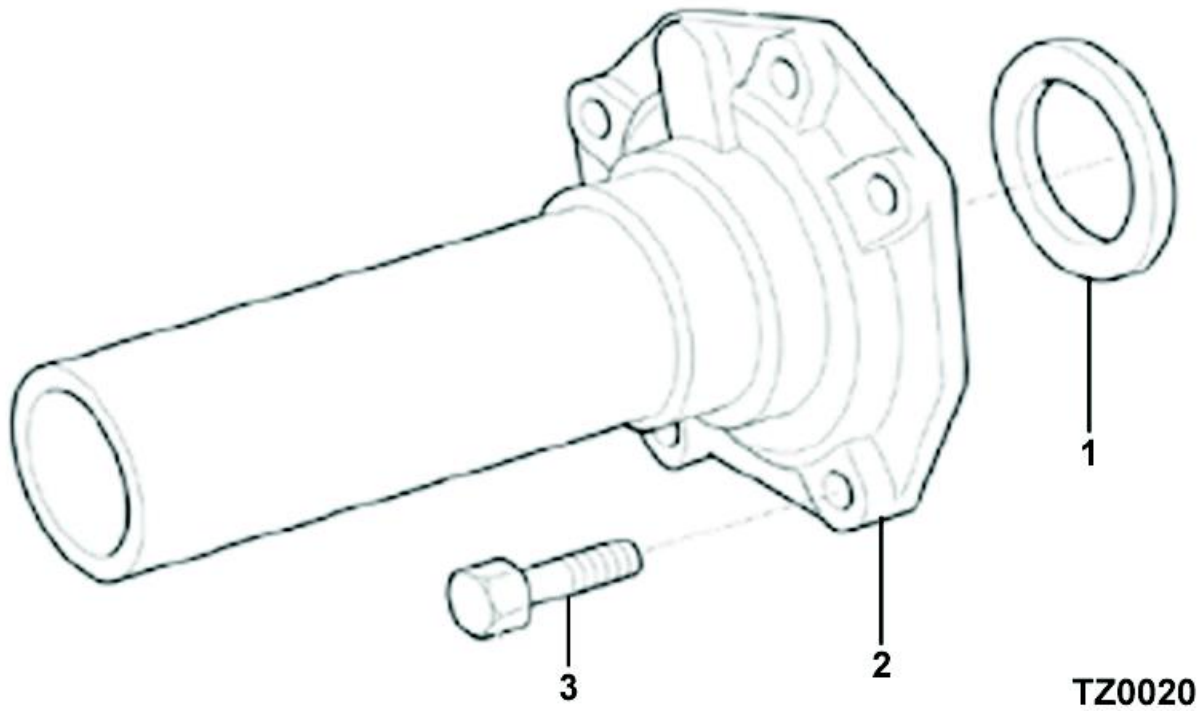

FRONT BEARING COVER ASSY.

Item	Current Part	Description	Replaced Part	Qty.	Notes	Kits/Assys Where Needed
0	U8877737	FRONT BEARING COVER ASSY.		1		
1	X8870760	OIL SEAL		1		
2	8877738	FRONT BEARING COVER		1		
3	GMX-8-1089	SCREW		5	M10X25 HEX FLG HD	

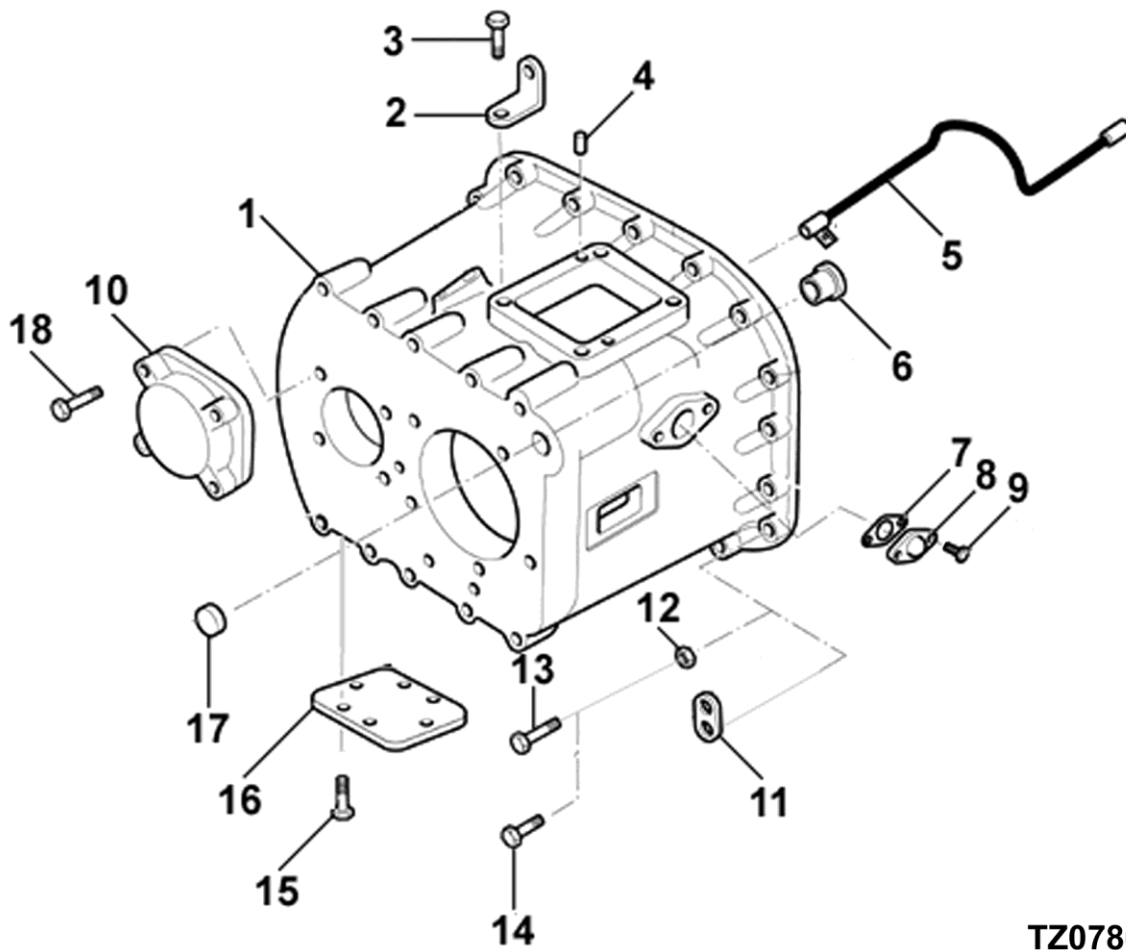

TZ0786

FRONT CASE ASSY

Item	Current Part	Description	Replaced Part	Qty.	Notes	Kits/Assys Where Needed
0	U8882448	FRONT CASE ASSY.		1		
1	8882608	FRONT CASE		1		
2	GX8879212	LIFTING EYE		1	15 MM	
3	GMX-8-1079	BOLT		4	M10X40	
4	X8870542	DOWEL		2	8,0 DIA X 16	
5	U8880098	OIL SPRAY BAR ASSY.		1		
6	8883756	BUSH	8882415	1	FOR MAIN SELECTOR SHAFT	
7	8870590	GASKET		1		
8	GX8870259	DETENT COVER		1		
9	GMX-8-0819	SCREW	GMX-8-0801	2	M8 X 16	
10	GX8880554	BEARING COVER		1		

Item	Current Part	Description	Replaced Part	Qty.	Notes	Kits/Assys Where Needed
LAYSHAFT						
11	GX8879211	LIFTING EYE		1		
12	GMX-9-1005	NUT		14	M10X1.5	
13	GMX-8-10111	BOLT		1	M10X65 HEX FLG HD	
13	GMX-8-1080	BOLT		13	M10X58	
14	GMX-8-1079	BOLT		4	M10X40	
15	GMX-8-1088	SCREW		6	M12X25 HEX FLG HD	
16	8881616	PTO PROVISION COVER		1		
17	GX8870278	CUP PLUG		1		
18	GMX-8-1240	SCREW		4	M12X25 HEX FLG HD	

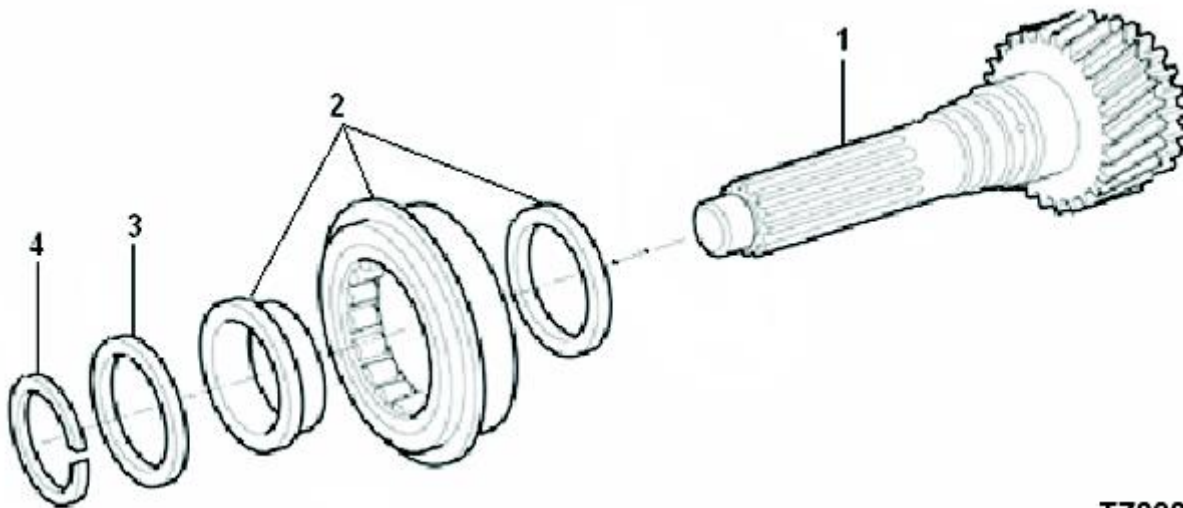

TZ0003

INPUT SHAFT ASSY.

Item	Current Part	Description	Replaced Part	Qty.	Notes	Kits/Assys Where Needed
0	U8882285	INPUT SHAFT ASSEMBLY		1		
1	8882283	INPUT SHAFT		1		
2	X8872593	INPUT SHAFT BEARING		1		
3	8877692	SPACER - GRADED 3.10		1	PACK: U8877691	
3	8877693	SPACER - GRADED 3.15		1	PACK: U8877691	
3	8877694	SPACER - GRADED 3.20		1	PACK: U8877691	
3	8877695	SPACER - GRADED 3.25		1	PACK: U8877691	
3	8877696	SPACER - GRADED 3.30		1	PACK: U8877691	
3	8877697	SPACER - GRADED 3.35		1	PACK: U8877691	
3	8877698	SPACER - GRADED 3.40		1	PACK: U8877691	
3	8877699	SPACER - GRADED 3.45		1	PACK: U8877691	
3	8877700	SPACER - GRADED 3.50		1	PACK: U8877691	
3	U8877691	SPACER - GRADED PACK		1		
4	X8877706	CIRCLIP		1		

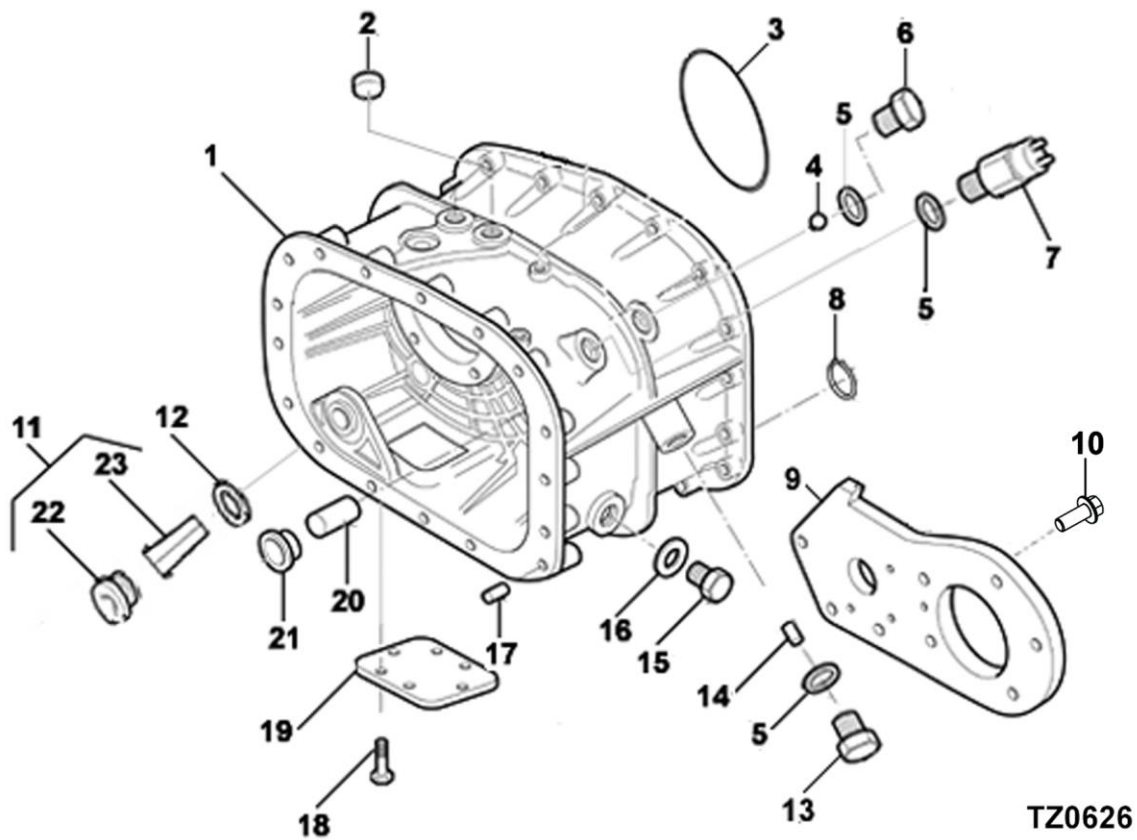

TZ0626

INTERMEDIATE CASE ASSY.

Item	Current Part	Description	Replaced Part	Qty.	Notes	Kits/Assys Where Needed
0	T21228	SERVICE KIT OIL STRAINER/ WASHER		1	INCLUDES 8876351, GX8876352 & X8880469	
0	U8876423	INTERMEDIATE CASE ASSY		1		
1	8876418	INTERMEDIATE CASE		1		
2	8876744	CORE PLUG OIL RESTRICTOR		1		
3	X8881475	O-RING		1	(109,5X3,0)	
4	X8870711	BALL		1	DIA.14	
5	5568510	O-RING		3		
6	GX8871502	PLUG		1	M16	
7	GX2771532	SWITCH REVERSE / RANGE		1		
8	X8881424	CIRCLIP		1		
9	U8883824	OIL PUMP ASSY.	GU8875469	1		
10	GMX-8-	SCREW		8	M10X25 HEX FLG HD	

Item	Current Part	Description	Replaced Part	Qty.	Notes	Kits/Assys Where Needed
	1089					
11	U8876353	OIL STRAINER ASSY.		1		T21228
12	X8880469	WASHER-OIL STRAINER / DRAIN		1		T21228
13	GX8871502	PLUG		1	M16	
14	8875267	PIN INTERLOCK		1		
15	GX8874942	OIL FILLER PLUG		1		
16	X8880519	WASHER-FILL/DRAIN FL		1		
17	X8870543	DOWEL		2	16,0 DI X 30,5	
18	GMX-8- 1088	SCREW		6	M12X25 HEX FLG HD	
19	8881616	PTO PROVISION COVER		1		
20	X8871377	BUSH		1		
21	8883756	BUSH	8882415	1	FOR MAIN SELECTOR SHAFT	
22	GX8876352	PLUG OIL STRAINER		1		
23	8876351	STRAINER-OIL		1		

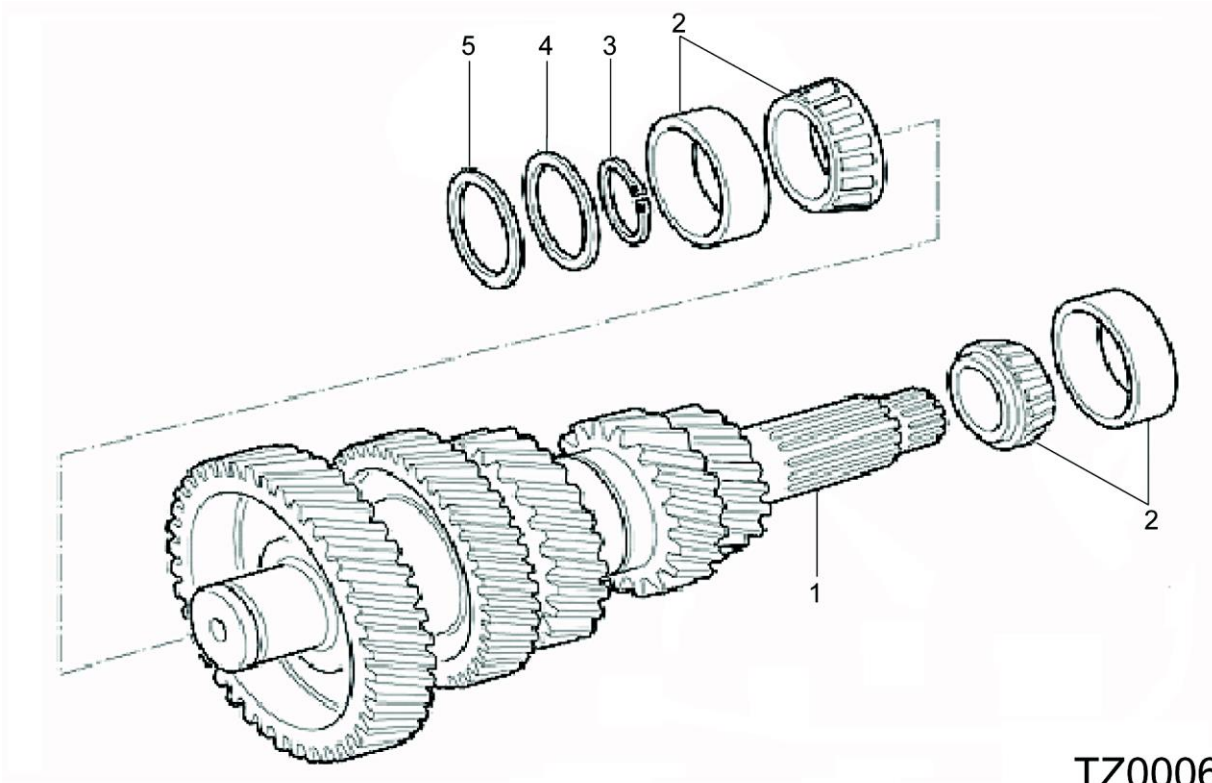

TZ0006

LAYSHAFT ASSY.

Item	Current Part	Description	Replaced Part	Qty.	Notes	Kits/Assys Where Needed
1	U8880746	LAYSHAFT ASSEMBLY		1		
2	X8880820	BEARING ASSEMBLY		2		
3	U8877534	CIRCLIP GRADED PACK		1		
3	X8870370	GR.C/CLIP 40 DIA. X 2.12 MM		1		
3	X8870371	GR.C/CLIP 40 DIA. X 2.07 MM		1		
3	X8870372	GR.C/CLIP 40 DIA X 2.02 MM		1		
3	X8871536	GR.C/CLIP 40 DIA. X 1.97 MM		1		
3	X8871537	GR.C/CLIP 40 DIA. X 1.92 MM		1		
3	X8871538	GR.C/CLIP 40 DIA. X 1.87 MM		1		
3	X8871539	GR.C/CLIP 40 DIA. X 1.82 MM		1		
3	X8871540	GR.C/CLIP 40 DIA. X 1.77 MM		1		

Item	Current Part	Description	Replaced Part	Qty.	Notes	Kits/Assys Where Needed
4	F88891	SHIM		1	S=0,051	
4	F88892	SHIM		1	S=0,127	
4	F88893	SHIM		1	S=0,254	
4	F88894	SHIM		1	S=0,508	
4	U8877535	SHIM PACK		1		
4	X8882272	SHIM		1	S=1,200	
5	8875879	SPACER		1		

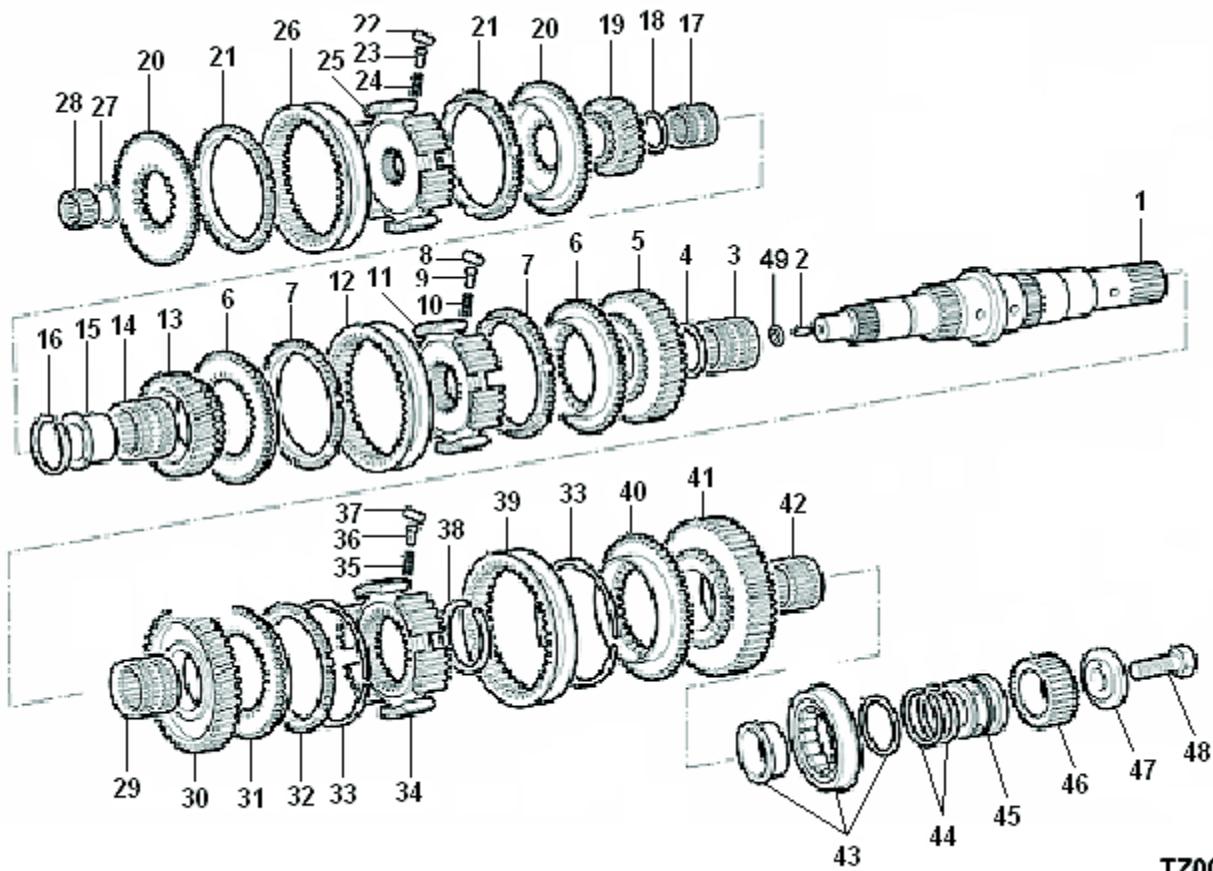

TZ0044

MAINSHAFT ASSY.

Item	Current Part	Description	Replaced Part	Qty.	Notes	Kits/Assys Where Needed
0	U8883423	MAINSHAFT ASSY.		1		
1	U8877186V	MAINSHAFT SUB ASSY.	U8877186	1		
2	X14851	DOWEL		1	5/16 DI X 1.50	
3	X8870177	NEEDLE ROLLER BRG. ASSY		1		
4	8872589	GEAR SPACER 1ST		1		
5	8876948	GEAR MAINSHAFT 1ST		1		
6	8877321	SYNCHRO FLANGE 1/2/3/4		2		
7	8883044	RING SYNCHRO 1ST/2ND	8882682	2		
8	X8870356	ROLLER		3		
9	8870352	PLUNGER		3		
10	8870444	SPRING COMPRESSION		3		
11	8875571	HUB-FIXED, 1ST/2ND		1		

Item	Current Part	Description	Replaced Part	Qty.	Notes	Kits/Assys Where Needed
12	8880460	SLIDING SLEEVE		1		
13	8876949	GEAR MAINSHAFT 2ND		1		
14	X8870177	NEEDLE ROLLER BRG. ASSY		1		
15	8882868	SLEEVE MAINSHAFT BEARING		1		
16	U8882558	GRADED CIRCLIP PACK		1		
16	X8870534	GR.CIRCLIP 46 DIA. X 2.10 MM		1	PACK: U8882558	
16	X8870535	GR.CIRCLIP 46 DIA. X 2.05 MM		1	PACK: U8882558	
16	X8870536	GR.CIRCLIP 46 DIA. X 2.00 MM		1	PACK: U8882558	
16	X8883040	CIRCLIP GRADED 46 DIA X2.15 MM		1	PACK: U8882558	
16	X8883041	CIRCLIP GRADED 46 DIA X 2.20 MM		1	PACK: U8882558	
17	X8875276	NEEDLE BEARING		1		
18	8872588	GEAR SPACER 4TH		1		
19	8880740	GEAR MAINSHAFT 3RD		1		
20	8877321	SYNCHRO FLANGE 1/2/3/4		2		
21	8883044	RING SYNCHRO 1ST/2ND	8882682	2		
22	X8870356	ROLLER		3		
23	8870352	PLUNGER		3		
24	8870444	SPRING COMPRESSION		3		
25	8875554	FIXED HUB 3RD/4TH		1		
26	8880460	SLIDING SLEEVE		1		
27	U8877531	GRADED CIRCLIP PACK		1		
27	X8870370	GR.C/CLIP 40 DIA. X 2.12 MM		1		
27	X8870371	GR.C/CLIP 40 DIA. X 2.07 MM		1		
27	X8870372	GR.C/CLIP 40 DIA X 2.02 MM		1		
28	X8870305	NEEDLE BRG.ROLLER ASSY		1		
29	X8870177	NEEDLE ROLLER BRG. ASSY		1		

Item	Current Part	Description	Replaced Part	Qty.	Notes	Kits/Assys Where Needed
30	8876477	GEAR MAINSHAFT CRAWLER		1		
31	8880059	SYNCHRO FLANGE CRAWLER		1		
33	X8873994	CIRCLIP SYNCHRO. ASSY.		1		
34	8875604	FIXED HUB REVERSE/CRAWLER		1		
35	8870444	SPRING COMPRESSION		3		
36	8870352	PLUNGER		3		
37	X8870356	ROLLER		3		
38	U8877532	GRADED CIRCLIP PACK		1		
38	X8870378	CIRCLIP-GR.DIA.60 X 2.10 MM		1		
38	X8870379	CIRCLIP-GR.DIA.60 X 2.05 MM		1		
38	X8870380	CIRCLIP-GR.DIA.60 X 2.00 MM		1		
39	8880461	SLIDING SLEEVE		1		
40	8870415	SYNCHRO FLANGE REVERSE		1		
41	8876478	GEAR MAINSHAFT REVERSE		1		
42	X8870178	NEEDLE ROLLER BRG. ASSY		1		
43	X8877164	BEARING REAR MAINSHAFT		1		
44	X8875532	SEALING RING		2		
45	8877115	OIL MUFF		1		
46	8881203	SUN GEAR		1		
47	8880594	RETAINER		1		
48	GX8870699	SCREW		1	M16X45 HEX HD	
49	8876298	RESTRICTOR		1		

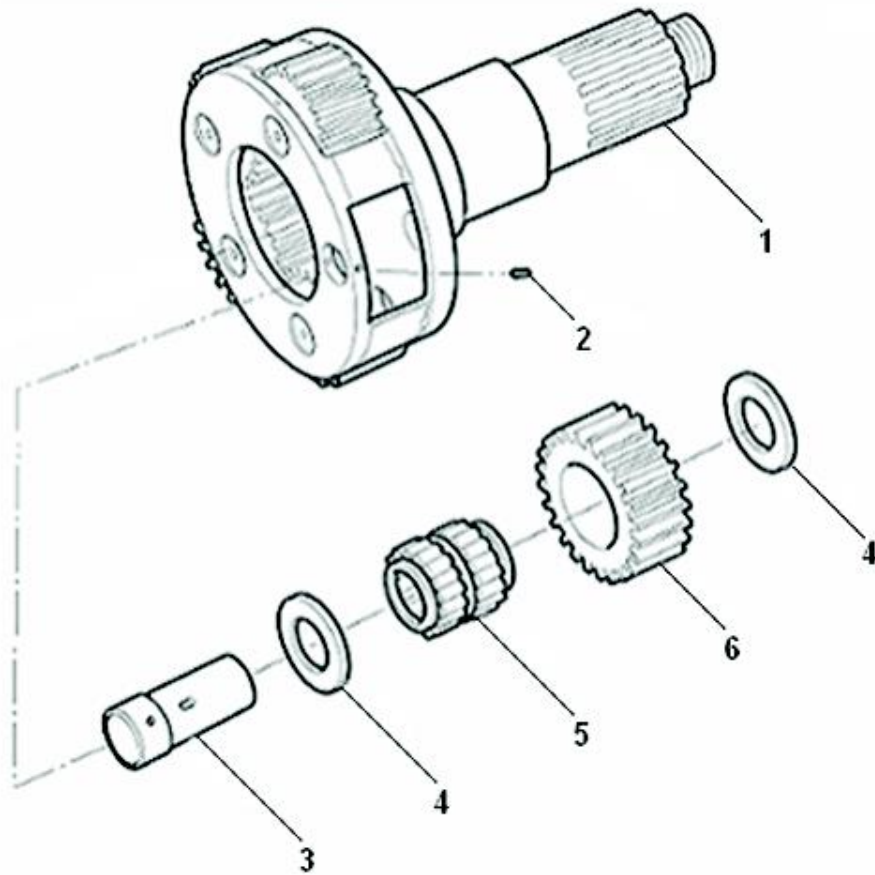

TZ0008

PLANET GEAR SPINDLE ASSY.

Item	Current Part	Description	Replaced Part	Qty.	Notes	Kits/Assys Where Needed
0	U8880229	PLANET GEAR SPINDLE ASSY		1		
1	U8882529	OUTPUT SHAFT ASSY.		1		
2	MX-11-0601	SCREW		5	M6 X 10 SKT HD SET	
3	8876972	SPINDLE PLANET GEAR		5		
4	8876893	WASHER		10		
5	U8876969	NEEDLE ROLL BRG. ASSY. PCK.		5		
6	8881523	GEAR PLANET		5		

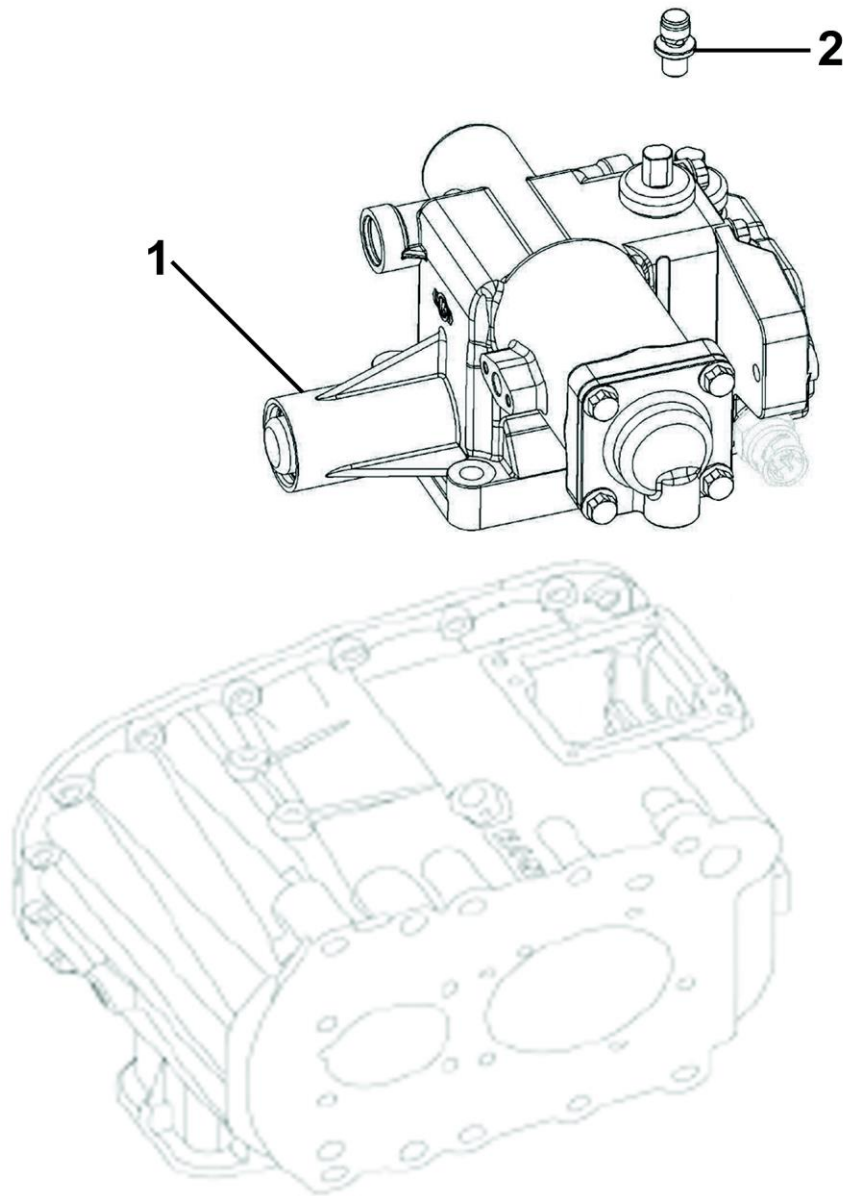

TZ0026

PPA UNIT 9 SPEED

Item	Current Part	Description	Replaced Part	Qty.	Notes	Kits/Assys Where Needed
1	U8882440	PPA UNIT		1	9 SPEED	
2	GX8882660	BREATHER		1		

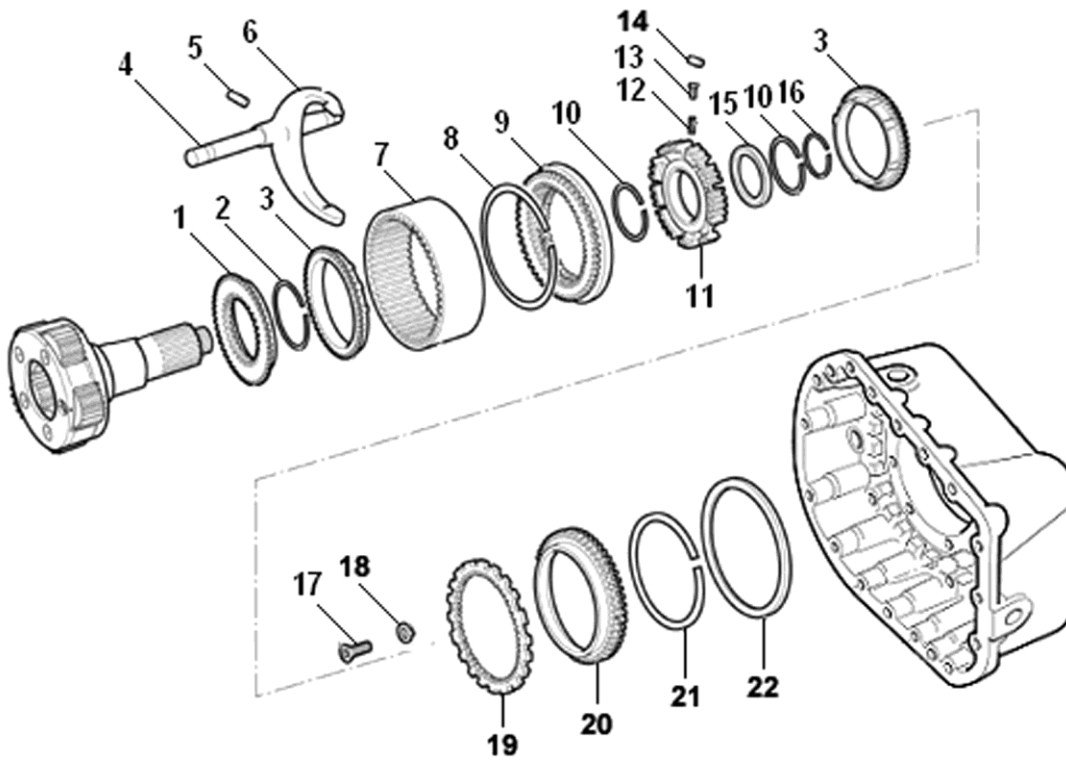

TZ0033

RANGE ASSY.

Item	Current Part	Description	Replaced Part	Qty.	Notes	Kits/Assys Where Needed
0	U8883422	RANGE ASSY.		1		
1	8877323	SYNCHRO FLANGE		1		
2	X8870342	CIRCLIP		1		
3	8877442	SYNCHRO RING - RANGE		2		
4	8872626	HI-LO SHIFT ROD		1		
5	X8878665	DOWEL	X8870726	1	ECO-0015293	
6	8872737	HIGH/LOW SHIFT FORK	8872737,8883677	1		
7	8880231	ANNULUS		1		
8	X8875296	CIRCLIP		1		
9	8883372	SLIDING SLEEVE		1		
10	X8870341	CIRCLIP		1		
11	8875881	FIXED HUB		1		
12	8870444	SPRING COMPRESSION		9		
13	8870352	PLUNGER		9		
14	X8870355	ROLLER		9		

Item	Current Part	Description	Replaced Part	Qty.	Notes	Kits/Assys Where Needed
15	X8870844	BEARING		1		
16	X8870344	CIRCLIP		1		
17	GMX-8-0806	SCREW		3	M8X20	
18	8870848	RETAINER		3		
19	8875646	REACTION PLATE		1		
20	8877322	SYNCHRO FLANGE		1		
21	X8873993	CIRCLIP		1		
22	8870808	SPACER		1		

Group: RANGE CONTROL ASSY.

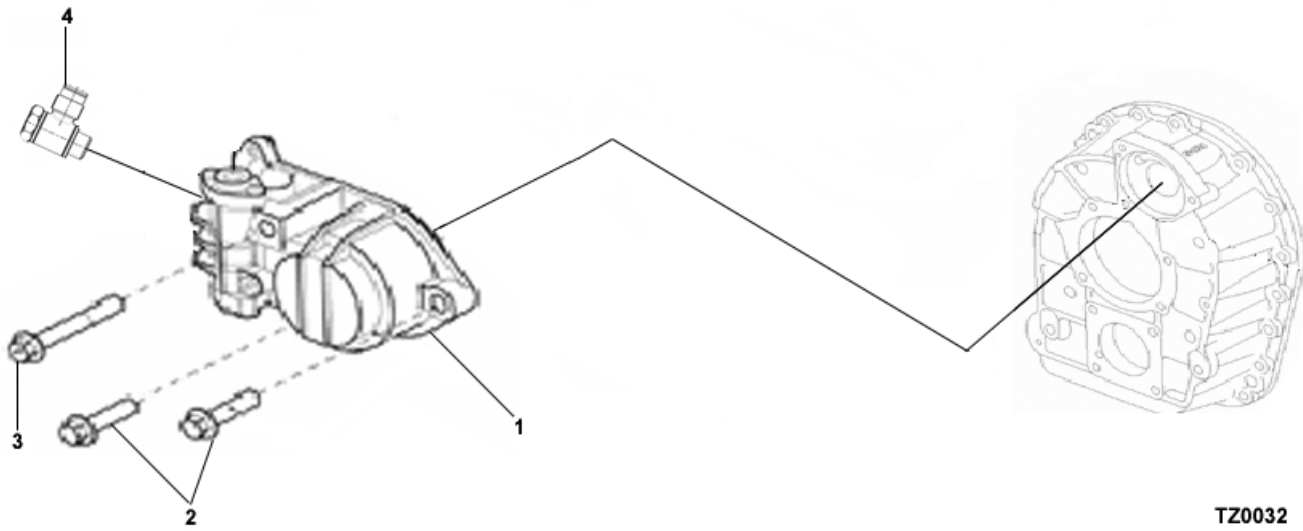

RANGE CONTROL ASSY.

Item	Current Part	Description	Replaced Part	Qty.	Notes	Kits/Assys Where Needed
0	ZU8882216	INTEGRATED RANGE CONTROL ASSY.		1		
1	X8882214	INTEGRATED AIR VALVE ELECTRIC		1		
2	GMX-8-1047	SCREW		2	M10 X 35 HEX.FLG.HD	
3	GMX-8-1087	BOLT		1	M10 X 70	
4	U8883020	BANJO ADAPTOR		1	G1/4 TO 8MM TUBE	

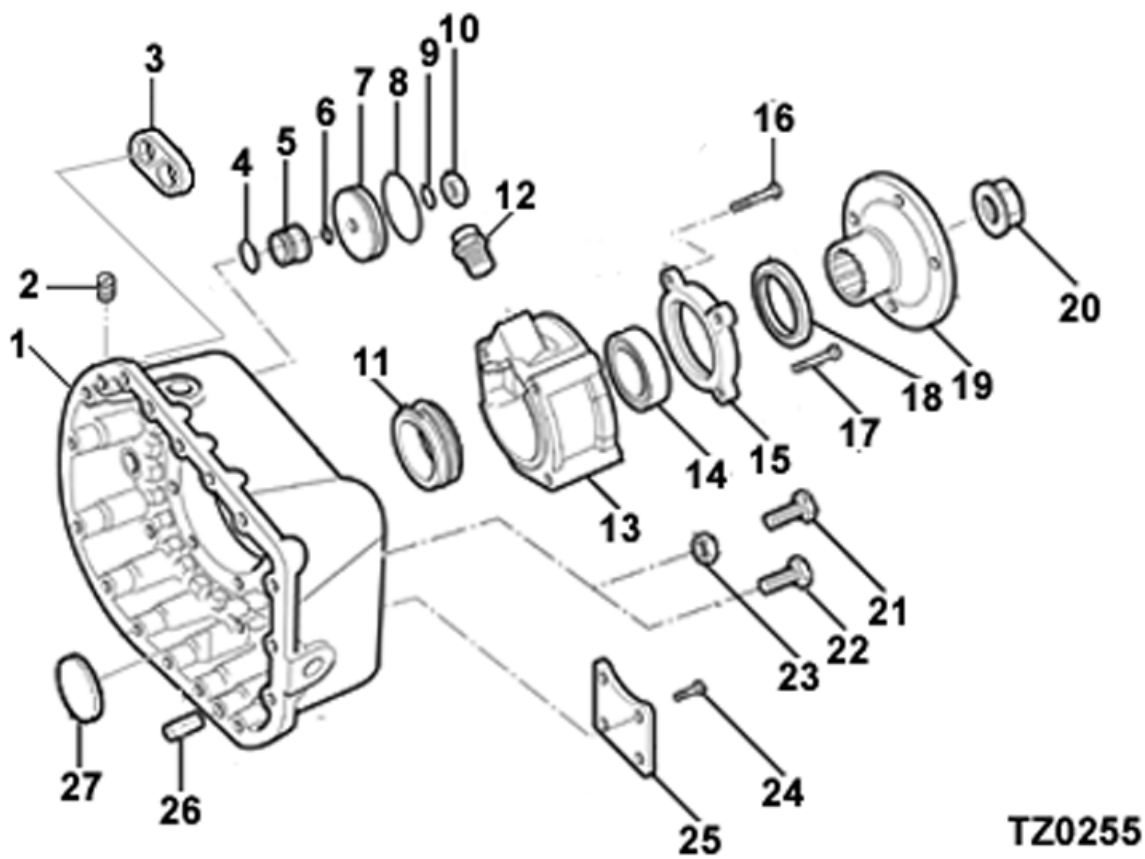

TZ0255

REAR CASE ASSY.

Item	Current Part	Description	Replaced Part	Qty.	Notes	Kits/Assys Where Needed
0	U8882288	REAR CASE ASSY.		1		
1	8882337	REAR CASING		1		
2	GMX-8-0857	PLUG		1	M8 X 1.25	
3	GX8879211	LIFTING EYE		2		
4	X8875292	O-RING		1		
5	8878240	BUSH	8875293	1		
6	X8871258	O-RING		1	DIA.24,5	
7	8875179	PISTON RANGE CYLINDER		1		
8	14344	PISTON O RING		1		
9	14345	PISTON O RING		1		
10	GMX-9-1602	NUT		1	M16	
11	8882428	TACHOGRAPH ROTOR		1		

Item	Current Part	Description	Replaced Part	Qty.	Notes	Kits/Assys Where Needed
12	X8874937	PROTECTION PLUG		1	M18	
13	8874013	ELECTR. SPEEDO HOUSING		1		
14	X8872721	BEARING		1		
15	8871992	REAR COVER		1		
16	GMX-8-1095	BOLT		3	M10X95 HEX FLG HD	
17	GMX-8-1096	BOLT		1	M10X95 HEX FLG HD	
18	X8872722	OIL SEAL		1		
19	GX8877225	COUPLING FLANGE		1		
20	GX8870553	NUT		1		
21	GMX-8-1080	BOLT		16	M10X58	
22	GMX-8-10111	BOLT		1	M10X65 HEX FLG HD	
23	GMX-9-1005	NUT		17	M10X1.5	
24	GMX-8-1240	SCREW		4	M12X25 HEX FLG HD	
25	GX8873917	LAYSHAFT REAR COVER		1		
26	X8870543	DOWEL		2	16,0 DI X 30,5	
27	14373	DISC MAGNET		1		

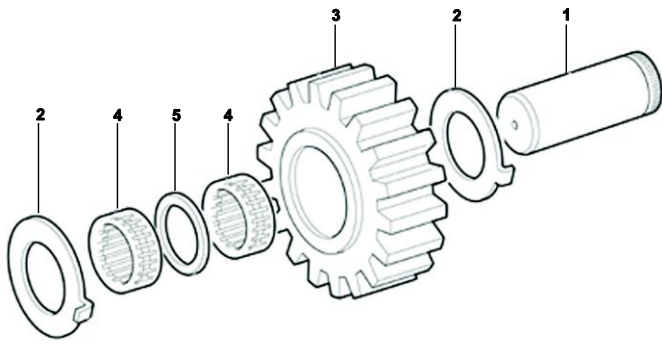

TZ0007

REVERSE IDLER ASSY.

Item	Current Part	Description	Replaced Part	Qty.	Notes	Kits/Assys Where Needed
1	8883246	REVERSE IDLER SHAFT		1		
2	8870343	THRUST WASHER		2		
3	8876457	REVERSE IDLER GEAR		1		
4	X8872478	NEEDLE ROLLER BRG		2		
5	8872479	SPACER		1		

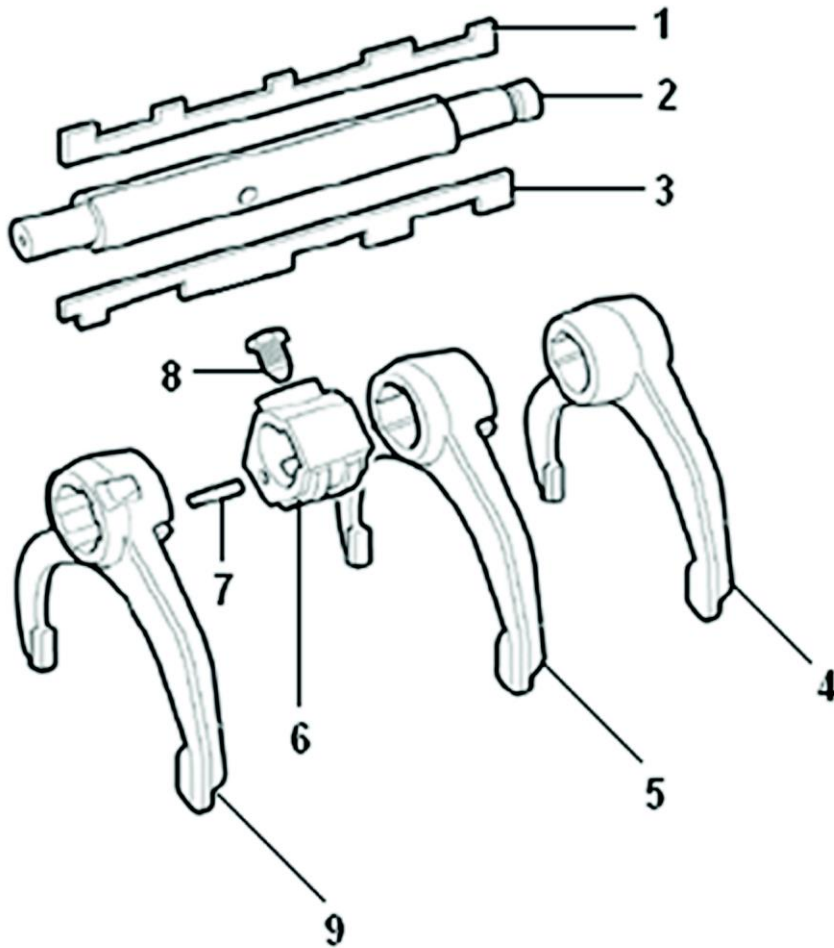

PU0009

SELECTOR ASSY.

Item	Current Part	Description	Replaced Part	Qty.	Notes	Kits/Assys Where Needed
0	U8882444	SELECTOR ASSY.		1		
1	8872328	SELECTOR KEY		1		
2	8882443	SELECTOR SHAFT		1		
3	8880759	INTERLOCK KEY	8872327	1		
4	8875499	FORK CRAWLER/REVERSE	8882629	1		
5	8880760	FORK 1ST/2ND	8882630	1		
6	8874755	SELECTOR BLOCK		1		
7	X8870277	DOWEL		1		
8	8873691	SCREW		1	M10X23 HEX HD	
9	8882631	FORK 3RD/4TH		1		

Copyright Eaton Corporation, 2009.
Eaton hereby grants their customers,
vendors, or distributors permission to
freely copy, reproduce and/or distribute
this document in printed format. It may
be copied only in its entirety without
any changes or modifications. THIS
INFORMATION IS NOT INTENDED FOR
SALE OR RESALE, AND THIS NOTICE
MUST REMAIN ON ALL COPIES.

