

**EATON
MEDIUM DUTY
SYNCHROMESH TRANSMISSIONS**

**BMC Turkey
Y08011
FS V8209A**

Illustrated Parts List
Ersatzteilleste
Catalogue Rechange
Catalogo Ricambi
Catalogo de Piezas de Recambio

12/97

Section	English	Deutsch	Francais	Italiano	Espanol	Section
1a	Front Case Assy	Vorderes gehause	Carter-AV	Scatola-Anteriore	Caja-Delantera	1a
1b	Intermediate Case Assembly	Zwischengehause	Carter-intermediaire	Scatola-intermedia	Caja-Intermedia	1b
2	Input Shaft Assembly	Antriebswelle	Arbre D'Entree	Complessivo Albero entrata	Conjunto Eje Primario	2
3	Front Cover Assembly	Vorderer lagerdeckel	Couvercleavant	Complessivo Coperchio anteriore	Conjunto Tapa Delantera	3
4	Mainshaft Assembly	Hauptwelle	Arbre Principal Assemble	Complessivo Albero Principale	Conjunto Eje Principal	4
5	Layshaft Assembly	Vorgelewelle	Arbre Intermediaire	Complessivo Contralbero	Conjunto Eje Secundario	5
6	Reverse Idler Gear Assy	Ruckwärtsgang-Umkehrrod	Pignon De Renvoi Marche AR	Complessivo Ingranaggio Rinvio Retromarcia	Engranaje inversor marcha atras	6
7	Shift Controls	Schaltung	Commandes de changement de vitesse	Comandi cambio	Mandos del cambio	7
8	Remote Control assy	Fernschaltung	Commande a distance	Complessivo comando a distanza	Conjunto control remoto	8
10	Planet Carrier Assembly	Planetenradtrager	Porte-Planetaire	Complessivo Scatola Satelliti	Conjunto del portapinion Satekite	10
11	Rear Case Assembly	Hinteres Gehäuse	Carter AR assemble	Scatola Posteriore-complessivo	Tapa Trasera-conjunto	11
12	Range Synchronizer Assy	Synchro-n-schalt	Synchro-selecteur	Sincronizzatore-selattore	Sincronizador-selector gama	12
13	Air system	Luftsystem	Systeme Pneumatique	Implanto Pneumatico	Sistema Del/Aire	13
14	Service kits & assemblies	Bau-und service-satze	Kits et ensembles	Corredi e complessivi de manutenzione	Juegos Y conjuntos de servicio	14

Section	English	Deutsch	Francaise	Italiano	Espaniol	Section
Note	Stocking quantity shows recommended quantities for 25 transmissions	Lagerempfehlung für 25 Getriebe	Quantite de stockage pour 25 unites	Quantita per 25 cambi	Cant. stock para 25 cajas de cambio	

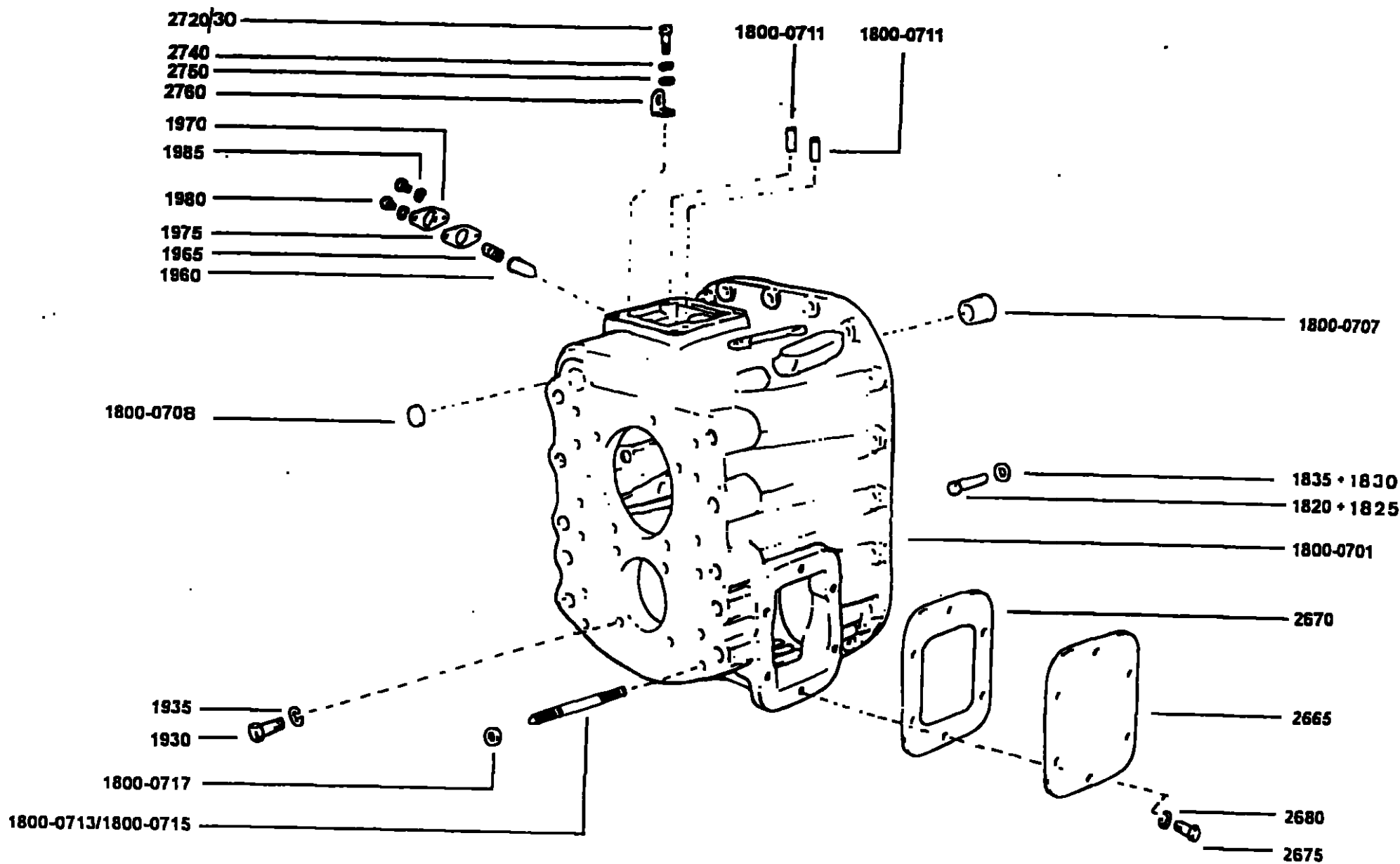

Front Case Assembly, Vorderes Gehäuse, Carter AV, Scatola Anteriore, Caja Delantera
Section 1a

Sequence No Sequence Nr Sequencia No Secuencia No	Qty Anzahl Qte Qta No.	Part No Teil Nr Piece No Rif No. Cat	English	Deutsch	Francais	Italiano	Espaniol	Stocking Qty Lager Empf Qte de Stockage Quantita Cant. Stock
1800	Ref	U8875958	Front Case Assy-vert.	Vorderes gehause	Carter-AV	Scatola anteriore	Caja delantera	-
1800-0701	1	8875929	Front case	Vorderes Gehäuse	Carter AV	Scatola anteriore	Tapa delantera	0
1800-0707	1	8872445	Bush	Buchse	Bague	Boccola	Casquillo	1
1800-0708	1	8870278	Plug	Verschlussschraube	Bouchon	Tappo	Tapon	2
1800-0709	-	X8877085	LOCTITE 243E	LOCTITE 243E	LOCTITE 243E	LOCTITE 243E	LOCTITE 243E	-
1800-0711	2	X8870542	Dowel	Passstift	Goupille	Grano di riferimento	Espiga	0
1800-0713	10	8873931	Stud M12 x 75	Stiftschraube	Goujon	Prigionero	Esparrago	0
1800-0715	2	8874899	Stud M12 x 65	Stiftschraube	Goujon	Prigionero	Esparrago	0
1800-0717	12	MX-9-1204	Self locking nut M12	Mutter	Ecrou	Dado	Tuerca	0
1800-0719	0		Oil trough					
1800-0721	0		Screw hammer drive	Schraube	Vis	Vite	Tornillo	
1800-0731	-	X10915	LOCTITE 270	LOCTITE 270	LOCTITE 270	LOCTITE 270	LOCTITE 270	-
1810	-	X8877790	LOCTITE 5205	LOCTITE 5205	LOCTITE 5205	LOCTITE 5205	LOCTITE 5205	-
1815			Cak screw M8	Schraube	Vis	Vite	Tornillo	
1820	4	MX-8-1004	Bolt M10 x 40	Schraube M10 x 40	Boulon M10 x 40	Bullone M10 x 40	Perno M10 x 40	0
1825	14	MX-8-1005	Bolt M10 x 55	Schraube M10 x 550	Boulon M10 x 55	Bullone M10 x 55	Perno M10 x 55	0
1830	14	MX-9-1001	Nut M10 x 1.5	Mutter M10 x 1.5	Ecrou M10 x 1.5	Dado M10 x 1.5	Tuerca M10 x 1.5	0
1835	32	X11245	Washer M10	Scheibe M10	Rondelle M10	Rondella M10	Arandela M10	0
1840	0		Bolt M10 x 60	Schraube	Boulon	Bullone	Perno	0
1920	0		Bearing Cover	Lagerdeckel	Couvercle AV	Coperchio anteriore	Tapa delantera	1
1925	-		Flange sealant	Dichtmittel	Produit d'entancheite	Sigillante flangia	Sellabridas	-
1930	4	MX-8-1209	Screw M12 x 25	Schraube M12	Vis M12	Vite M12	Tornillo M12	-
1935	4	MX-3-1201	Spring washer M12	Federscheibe M12	Rondelle grower M12	Rosetta elastica M12	Arandela elastica M12	0
1960	1	8873654	Plunger	Führungstift	Plongeur	Pistone	Vastago	2
1965	1	8874897	Spring	Feder	Ressort	Molla	Muelle	1

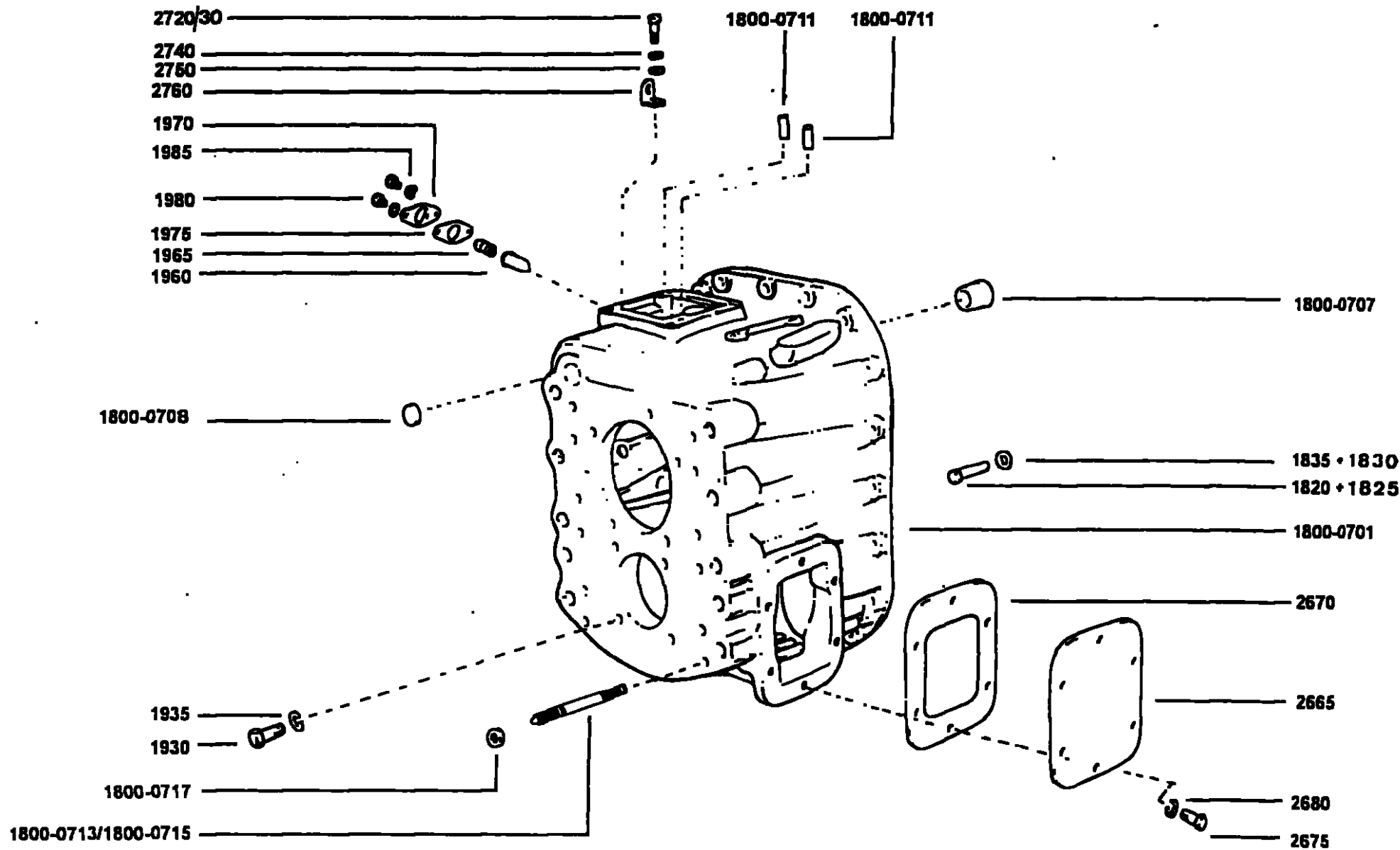

Section 1a

Sequence No Sequence Nr Sequela No Sequela No Secuencia No	Qty Anzahl Qte Qta No.	Part No Telle Nr Piece No RH No. Cat	English	Deutsch	Francais	Italiano	Espaniol	Stocking Qty Lager Empf Qte de Stockage Quantita Cant. Stock
1970	1	8870259	Cover	Deckel	Couvercle	Coperchio	Tapn reten	0
1975	1	8870590 (T20809)	Gasket	Dichtung	Joint	Guarnizione	Junta	2
1980	2	MX-8-0811	Screw M8 x 20	Schraube M8 x 20	Vis M8 x 20	Vite M8 x 20	Tornillo M8 x 20	0
1985	2	MX-3-0801	Spring washer M8	Federscheibe M8	Rondelle grower M8	Rosetta elastica M8	Arandela elastica M8	0
1990	0		Bracket, range inhibitor	Halter-	Support-	Supporto-	Soporte-	-
2665	1	2005144	Cover	Deckel	Couvercle	Coperchio	Tapa	0
2670	1	8877779 (T20809)	Gasket	Dichtung	Joint	Guarnizione	Junta	-
2675	6	MX-8-1001	Screw M10 x 20	Schraube M10 x 20	Vis M10 x 20	Vite M10 x 20	Tornillo M10 x 20	0
2680	6	MX-3-1001	Spring washer M10	Federscheibe M10	Rondelle grower M10	Rosetta elastica M10	Arandela elastica M10	0
2705	0		Spacer	Distanzscheibe	Entretoise	Anello distanziale	Espaciador	0
2710	-	X8877790	LOCTITE 5205	LOCTITE 5205	LOCTITE 5205	LOCTITE 5205	LOCTITE 5205	-
2720	4	MX-8-1003	Screw M10 x 35	Schraube M10 x 35	Vis M10 x 35	Vite M10 x 35	Tornillo M10 x 35	0
2730	4	MX-8-1005	Bolt M10 x 55	Schraube M10 x 55	Boulon M10 x 55	Bullone M10 x 55	Perno M10 x 55	0
2740	8	MX-3-1001	Spring washer M10	Federscheibe M10	Rondelle grower M10	Rosetta elastica M10	Arandela elastica M10	0
2750	7	X11245	Washer M10	Scheibe M10	Rondelle M10	Rondella M10	Arandela M10	0
2760	1	20815	Lifting eye	Hebeose	Patte de levage	Anello di sollevamento	Placa de izar	0
1720			Rotation pin (Overdrive)	Stift (Schnellgang)	Goupille (Surmultiples)	Alberino (Surmultiplicata)	Pasador (Superdirecta)	0
1740			Screw M8 x 20 (Overdrive)	Scheibe M8 x 20 (Schnellgang)	Vis M8 x 20 (Surmultiples)	Vite M8 x 20 (Surmultiplicata)	Tornillo M8 x 20 (Superdirecta)	0
1750			Washer M8	Scheibe M8	Rondelle M8	Rondella M8	Arandela M8	0

Intermediate Case Assembly- Vertical, Zwischengehäuse- Vertikal, Carter Intermediaire- Vertical, Scatola intermedia, Caja intermedia,

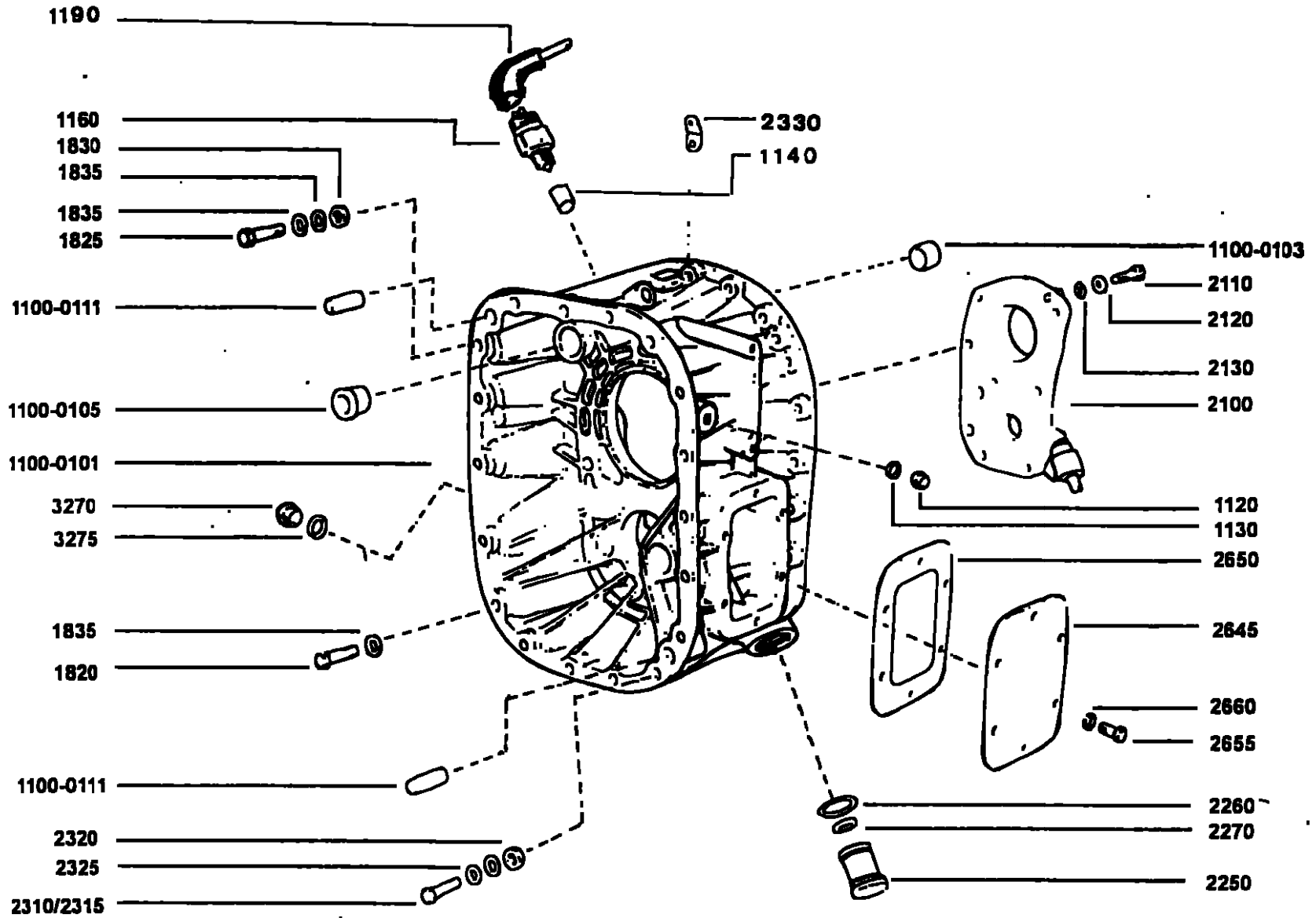

Intermediate Case Assembly, Zwischengehause, Carter Intermediaire, Scatola Intermedia, Caja Intermedia

Section 1b

Sequence No Sequence Nr Sequence No Sequela No Secuencia No	Qty Anzahl Qta Qta No.	Part No Teil Nr Piece No Rif No. Cat	English	Deutsch	Francals	Italiano	Espaniol	Stocking Qty Lager Empf Qta de Stockage Quantda Cant. Stock
1100	Ref	U8875628	Intermediate Case assy	Zwischengehause	Carter intermediaire	Scatola intermedia	Caja intermedia	0
1100-0101	1	8875304	Intermediate case	Zwischengehause	Carter intermediaire	Scatola intermedia	Caja inetrmedia	0
1100-0103	1	X8871377	Bush	Buchse	Bague	Boccola	Casquillo	2
1100-0105	1	8872445	Bush	Buchse	Bague	Boccola	Casquillo	1
1100-0111	2	X8870543	Dowel	Passstift	Goupille	Grano di riferimento	Espiga	0
1120	2	X8871502	Plug M16 x 1.5	Verschlusschraube M16	Bouchon M16 x 1.5	Tappo M16 x 1.5	Tapon M16 x 1.5	1
1130	2	X8875279	Washer	Scheibe	Rondelle	Rondella	Arandela	2
1135			Detent ball	Kugel	Bille	Sfera	Bola	2
1140	1	8875267	Interlock pin	Stift	Goupille	Alberino	Pasador	1
1145			Switch-range	Fahrbereichsschalter	Contacteur gamme	Interruttore gamma	Interruptor.gama	-
1150	0		Detent ball	Kugel	Bille	Sfera	Bola	2
1160	1	8876416	Switch-reverse	Ruckfahrtschalter	Contacteur marche AR	Interruttore retromarcia	Interruptor MA	2
1170	0		Switch-neutral	Neutralstellungschalter	Contacteur de point mort	Interruttore foils	Interruptor de punto	2
1180	0		Switch-reverse	Ruckfahrtschalter	Contacteur marche AR	Interruttore retromarcia	Interruptor de punto	2
1190	1	U2009052	Cable switch assy	Druckschalter-kabel	Contacteur-cable	Interruttore-cavo	Interruptor-cable	1
	OR							
1190	0		Switch protector					
2330	1	8874026	Lifting eye	Hebese	Patte de levage	Anello di sollevamento	Placa de izar	0
2100	1	U8875470	Oil pump assembly - 125 cooler	Olpumpe	Pompe a huile	Pompa olio	Bomba de aceite	0
2110	8	MX-8-1006	Bolt M10 x 30	Schraube M10 x 30	Boulon M10 x 30	Bullone M10 x 30	Perno M10 x 30	0
2120	8	MX-3-1001	Spring washer M10	Federscheibe M10	Rondelle grower M10	Rosetta elastica M10	Arandela elastica M10	0
2130	8	X11245	Plan washer	Scheibe	Rondelle	Rondella	Arandela	0
2250	1	U8876353	Oil strainer assy	Ol-Ablassschraube (Satz)	Crepine a huile	Complessivo filtro olio	Conjunto filtro aceite	2
2270	1	X8875280	Washer	Scheibe	Rondelle	Rondella	Arandela	2

Intermediate Case Assembly- Vertical, Zwischengehäuse- Vertikal, Carter intermediaire- Vertical, Scatola intermedia, Caja intermedia,

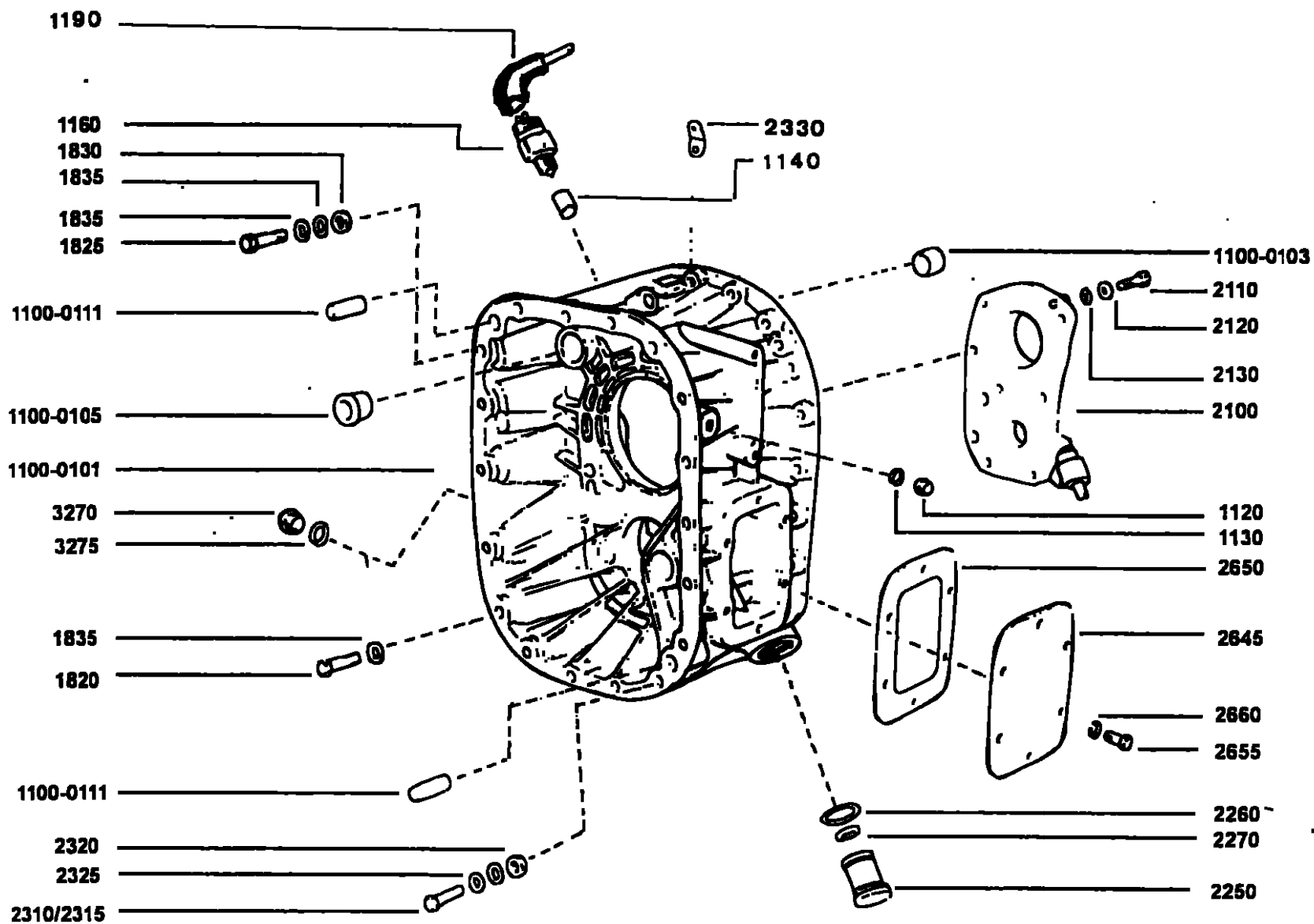

Sequence No Sequence Nr Sequela No Secuencia No	Qty Anzahl Qte Qta No.	Part No Telle Nr Piece No Rif No. Cat	English	Deutsch	Francais	Italiano	Espaniol	Stocking Qty Lager Empf Qte de Stockage Quantita Cant. Stock
2305	-	X8877790	LOCTITE 5205	LOCTITE 5205	LOCTITE 5205	LOCTITE 5205	LOCTITE 5205	-
2310	15	MX-8-1005	Bolt M10 x 55	Schraube M10 x 55	Boulon M10 x 55	Bullone M10 x 55	Perno M10 x 55	0
2315	2	MX-8-1013	Bolt M10 x 60	Schraube M10 x 60	Boulon M10 x 60	Bullone M10 x 60	Perno M10 x 60	0
2320	17	MX-9-1001	Nut M10 x 1.5	Mutter M10 x 1.5	Ecrou M10 x 1.5	Dado M10 x 1.5	Tuerca M10 x 1.5	0
2325	29	X11245	Washer M10	Scheibe M10	Rondelle M10	Rondella M10	Arandela M10	0
2645	1	2005144	Cover	Deckel	Couvercle	Coperchio	Tapa	0
2650	1	8877779 (T20609)	Gasket	Dichtung	Joint	Guarnizione	Junta	-
2655	6	MX-8-1001	Screw M10 x 20	Schraube M10 x 20	Vis M10 x 20	Vite M10 x 20	Tornillo M10 x 20	0
2660	6	MX-3-1001	Spring washer M10	Federschabe M10	Rondelle grower M10	Rosetta elastica M10	Arandela elastica M10	0
3270	1	X8874942	Plug M24	Verschlusschraube M24	Bouchon M24	Tappo M24	Tapon M24	2
3275	1	X8875238	Washer M24	Scheibe M24	Rondelle M24	Rondella M24	Arandela M24	0

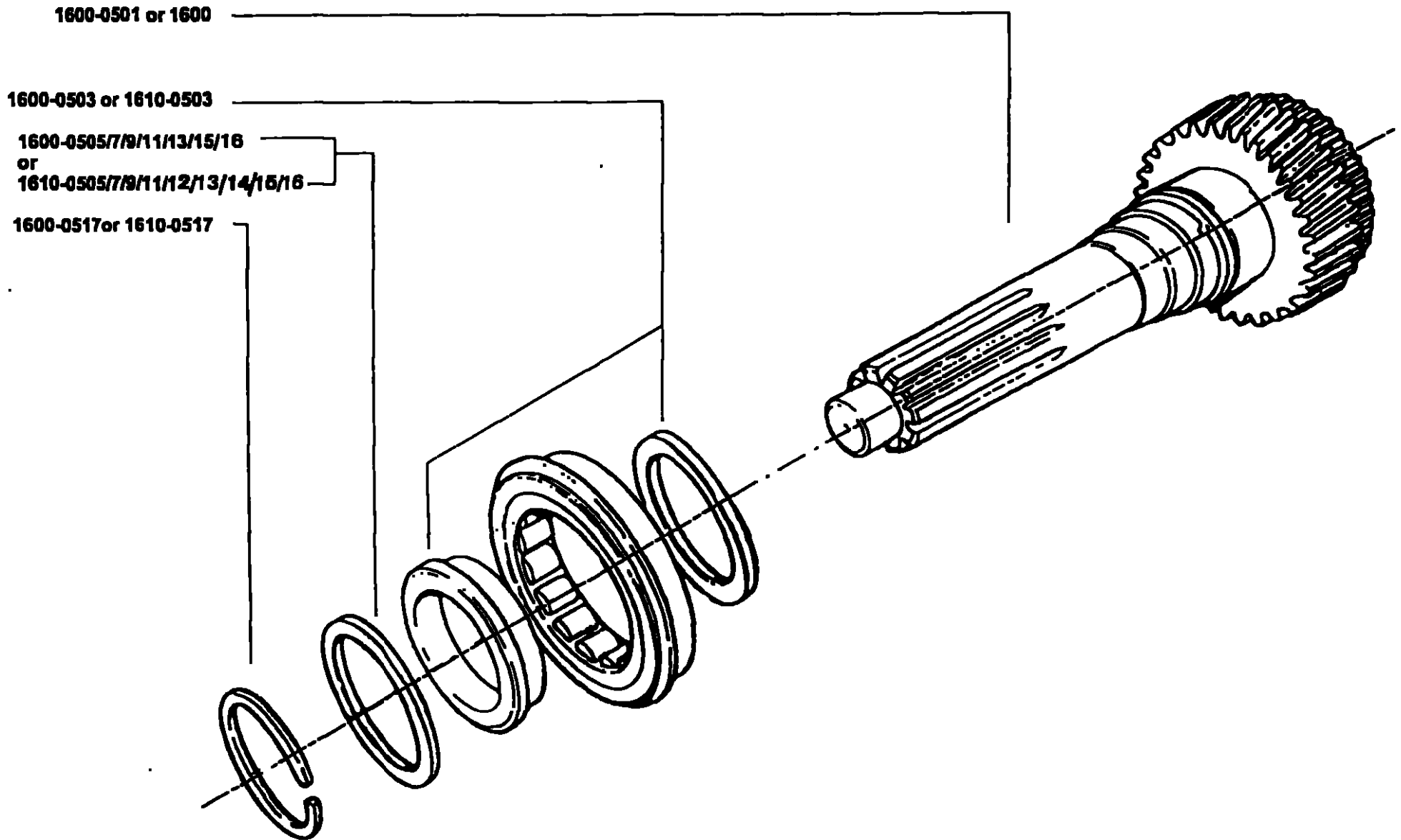

Input Shaft Assembly, Antriebswelle, Arbre d'Entree, Albero di Entrata, Eje Primario
Section 2

Sequence No	Qty	Part No	English	Deutsch	Francaise	Italiano	Espanol	Stock Qty
1600	Ref	U8876454	Input shaft assembly	Antriebswelle	Arbre d'entree	Albero entrata	Eje primario	1
1600-0501	1	8877702	Input shaft	Antriebswelle	Arbe d'entree	Albero entrata	Eje primario	2
1610-0503	1	X8872593 (T20608)	Bearing, input shaft (U8877703)	Rollenlager	Roulement de l'arbre d'entree	Cuscinetto a rulli	Cojnete de rodillos	2
1610-0505	1	8877692	Spacer 3.10mm (U8877691)	Distanzring 3.10mm	Entretoise 3.10mm	Distanziale 3.10mm	Separador 3.10mm	1
1610-0507	1	8877693	Spacer 3.15mm (U8877691)	Distanzring 3.15mm	Entretoise 3.15mm	Distanziale 3.15mm	Separador 3.15mm	1
1610-0509	1	8877694	Spacer 3.20mm (U8877691)	Distanzring 3.20mm	Entretoise 3.20mm	Distanziale 3.20mm	Separador 3.20mm	1
1610-0511	1	8877695	Spacer 3.25mm (U8877691)	Distanzring 3.25mm	Entretoise 3.25mm	Distanziale 3.25mm	Separador 3.25mm	1
1610-0512	1	8877696	Spacer 3.30mm (U8877691)	Distanzring 3.30mm	Entretoise 3.30mm	Distanziale 3.30mm	Separador 3.30mm	1
1610-0513	1	8877697	Spacer 3.35mm (U8877691)	Distanzring 3.35mm	Entretoise 3.35mm	Distanziale 3.35mm	Separador 3.35mm	1
1610-0514	1	8877698	Spacer 3.40mm (U8877691)	Distanzring 3.40mm	Entretoise 3.40mm	Distanziale 3.40mm	Separador 3.40mm	1
1610-0515	1	8877699	Spacer 3.45mm (U8877691)	Distanzring 3.45mm	Entretoise 3.45mm	Distanziale 3.45mm	Separador 3.45mm	1
1610-0516	1	8877700	Spacer 3.50mm (U8877691)	Distanzring 3.50mm	Entretoise 3.50mm	Distanziale 3.50mm	Separador 3.50mm	1
1610-0521	1	X8877706	Circlip (U8876148)	Sicherungring	Circlips	Anello de sicurezza	Anillo elastico	2

2000-0803

2000-0801

1935

1930

2030

2020

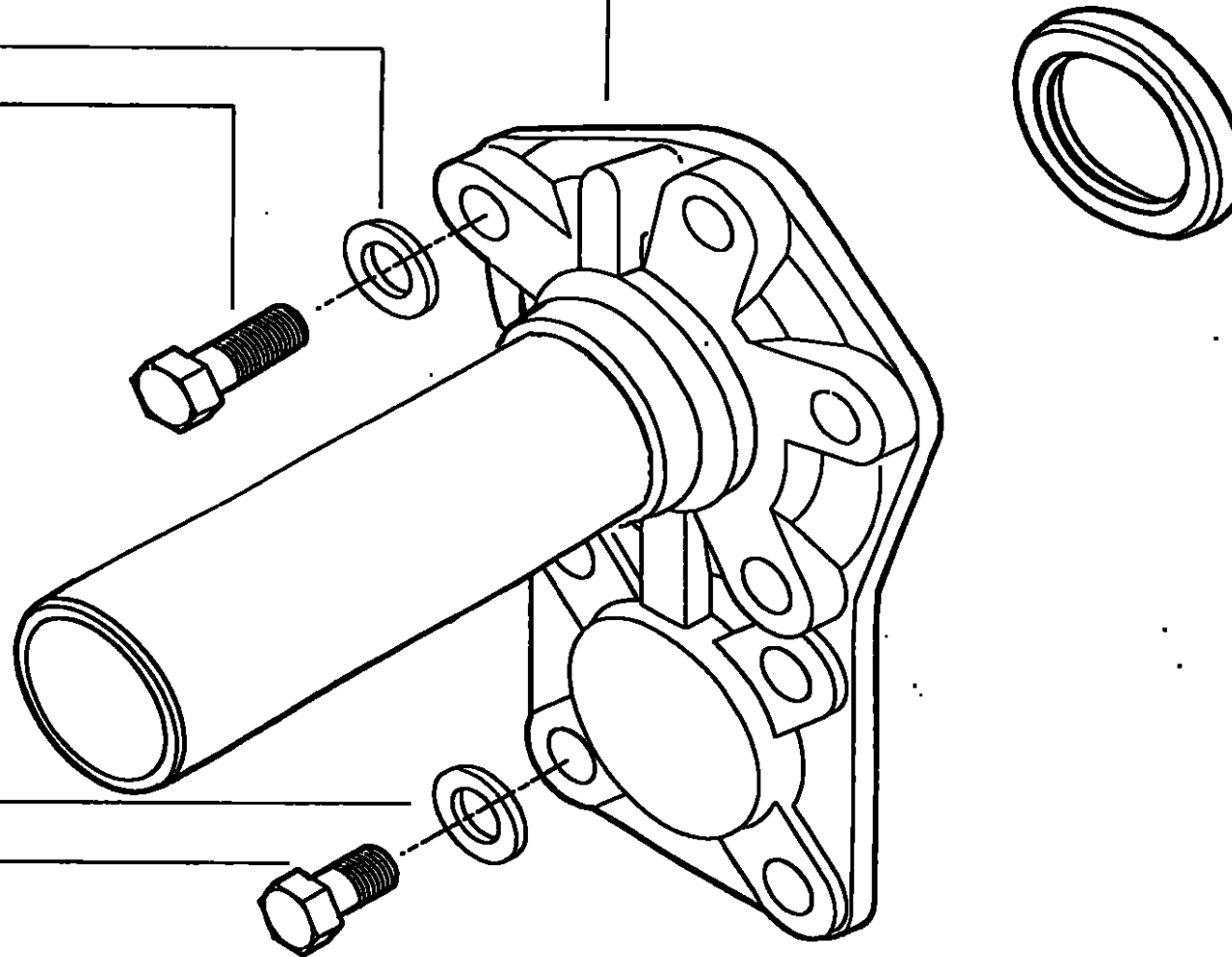

Front Cover Assembly, Vorderer Lagerdeckel, Couvercle Avant, Complessivo Coperchio Anteriore, Conjunto Tapa Delantera
Section 3

Sequence No	Qty	Part No	English	Deutsch	Francais	Italiano	Espaniol	Stock Qty
2000	Ref	U8875968	Front cover assy	-	-	-	-	-
2000-0801	1	8875547	Front cover, 1-piece	Vorderer Lagerdeckel	Couvercle AV	Coperchio anteriore	Tapa delantera	1
2000-0803	1	X8870760 (T20609)	Oil seal, front cover	Oldichtung	Joint d'entancheite	Tenuta dell'olio	Reten	4
2010	-	X8877790	LOCTITE 5205	LOCTITE 5205	LOCTITE 5205	LOCTITE 5205	LOCTITE 5205	-
2020	5	MX-8-1002	Screw M10 x 25	Schraube M10	Boulons M10	Vite M10	Tornillo M10	-
2030	5	MX-3-1001	Spring washer M10	Federscheibe M10	Rondelle grower M10	Rosetta elastica M10	Arandela elastica M10	-

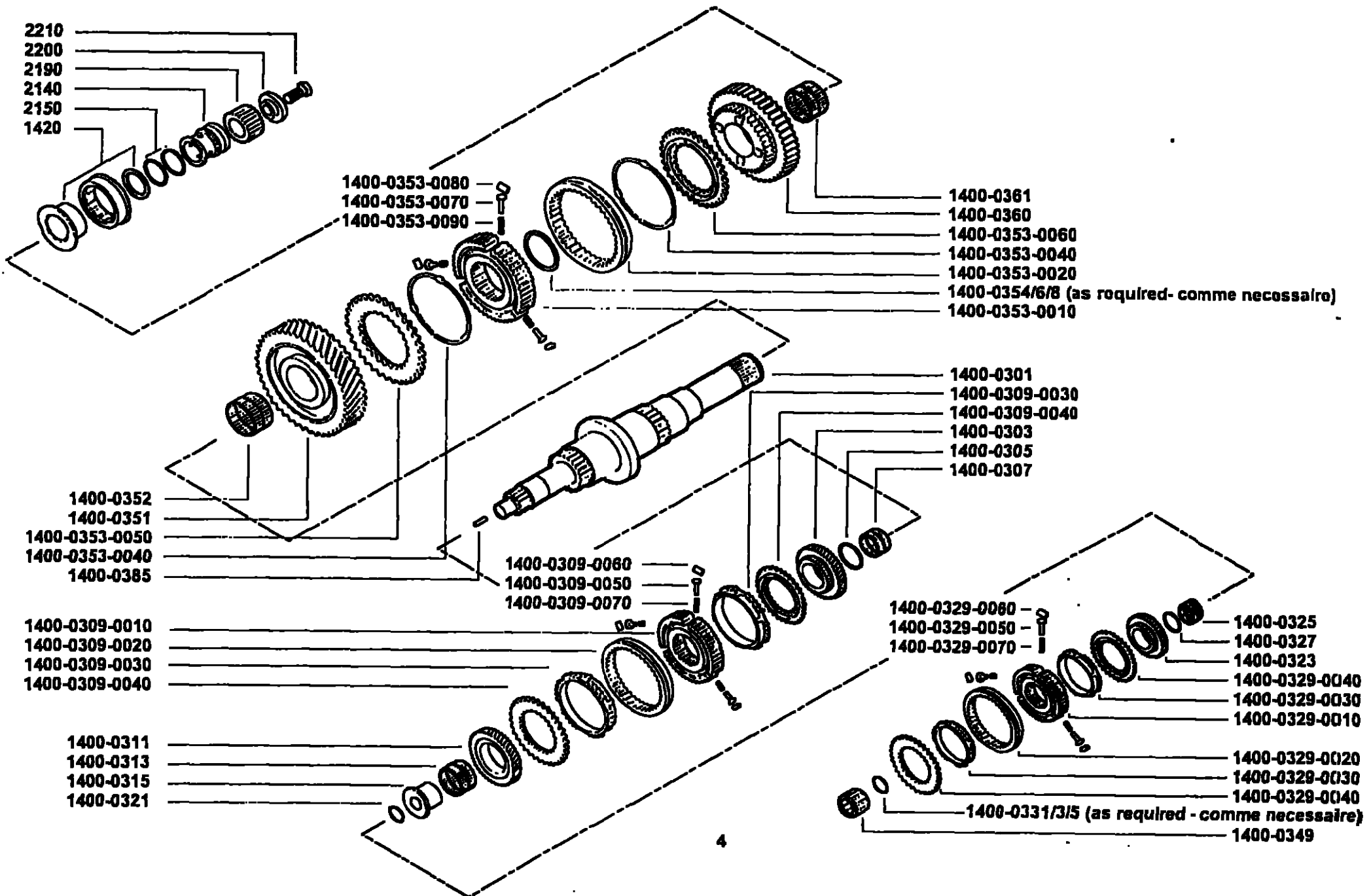

Mainshaft Assembly, Hauptwelle, Arbre Principal, Complessivo Albero Principale, Conjunto del Eje Principal

Section 4

Sequence No	Qty	Part No	English	Deutsch	Francais	Italiano	Espaniel	Stock Qty
1400	Ref	U8876301	Mainshaft assembly	-	-	-	-	-
1400-0301	1	U8875888	Mainshaft sub-assy	Hauptwelle	Arbre principal	Albero principale	Eje principal	-
1400-0303	1	8876441	Mainshaft gear 1st	Zahnrad 1 Gang	Pignon 1ere vitesse	Ingranaggio albero principale 1a	Engranje 1e	2
1400-0305	1	8872589	Spacer-2nd gear	Distanzscheibe	Entretoise	Anello distanziale	Espaciador	1
1400-0307	1	X8870177 (T20608)	Needle roller bearing	Nadelrollenlager	Roulement a aiguilles	Cuscinetto A rullini	Cojinete de rodillos en aguja	2
1400-0309-0010	1	8875571 (T20605)	Fixed hub 1st/2nd	Nabe, feststehend 1/2gang	Moyeu fixe 1ere/2eme	Mozzo fisso 1a/2a	Cubo o compana fija 1a/2a	2
1400-0309-0020	1	8875377 (T20605)	Sliding sleeve 2nd/3rd	Schiebemuffe 1./2. Gang	Anneau baladeur 1ere/2eme	Manicotto scorrevole 1a/2a	Casquillo deslizante 1a/2a	2
1400-0309-0030	2	8875135 (T20605)	Synchro ring (T20611)	Synchronring	Anneau de synchro	Anello sincronizzatore	Anillo sincronizador	4
1400-0309-0040	2	8871639 (T20605)	Synchro flange 2nd/3rd-(T20611)	Synchronflansch 2./3. Gang	Bride de synchro 2eme/3eme	Flangia sincronizzazione 2a/3a	Brida de sin. 2a/3a	4
1400-0309-0050	3	8870352 (T20605)	Plunger, synchro	Führungstift	Pionneur	Pistone	Vastago	12
1400-0309-0060	3	X8870356 (T20605)	Roller, synchro	Verriegelungsrolle	Rouleau	Rullo	Rodillo	12
1400-0309-0070	3	8870444 (T20605)	Spring, compression	Feder	Ressort	Molla	Muelle	12
1400-0311	1	8876439	Gear mainshaft 2nd	Zahnrad 2. Gang	Pignon 2 eme	Ingranaggio 2a	Engranaje 2a	2
1400-0313	1	X8870177 (T20608)	Needle roller bearing	Nadelrollenlager	Roulement a aiguiller	Cuscinetto a rullini	Cojinete de rodillos en aguja	2
1400-0315	1	8875196	Bearing sleeve 2nd	Lagermuffe 2 Gang	Manchon de roulement de 2eme	Manica cuscinetto 2	Casquillo cojinete 2a	2
1400-0321	1	X8870536	Circlip 46 dia x 2.00mm	Sicherungerring 2.0mm	Circlips 2.0mm	Anello di sicurezza 2.0mm	Anillo elastico 2.0mm	1
1400-0323			Gear mainshaft (overdrive)	Zahnrad (Schnellgang)	Pignon (Surmultiplee)	Ingranaggio (Surmultiplicata)	Engranaje (Suerdirecta)	2
1400-0323	1	8876438	Gear, mainshaft 3rd	Zahnrad 3. Gang	Pignon 3eme	ingranaggio 3	Engranaje 3a	2

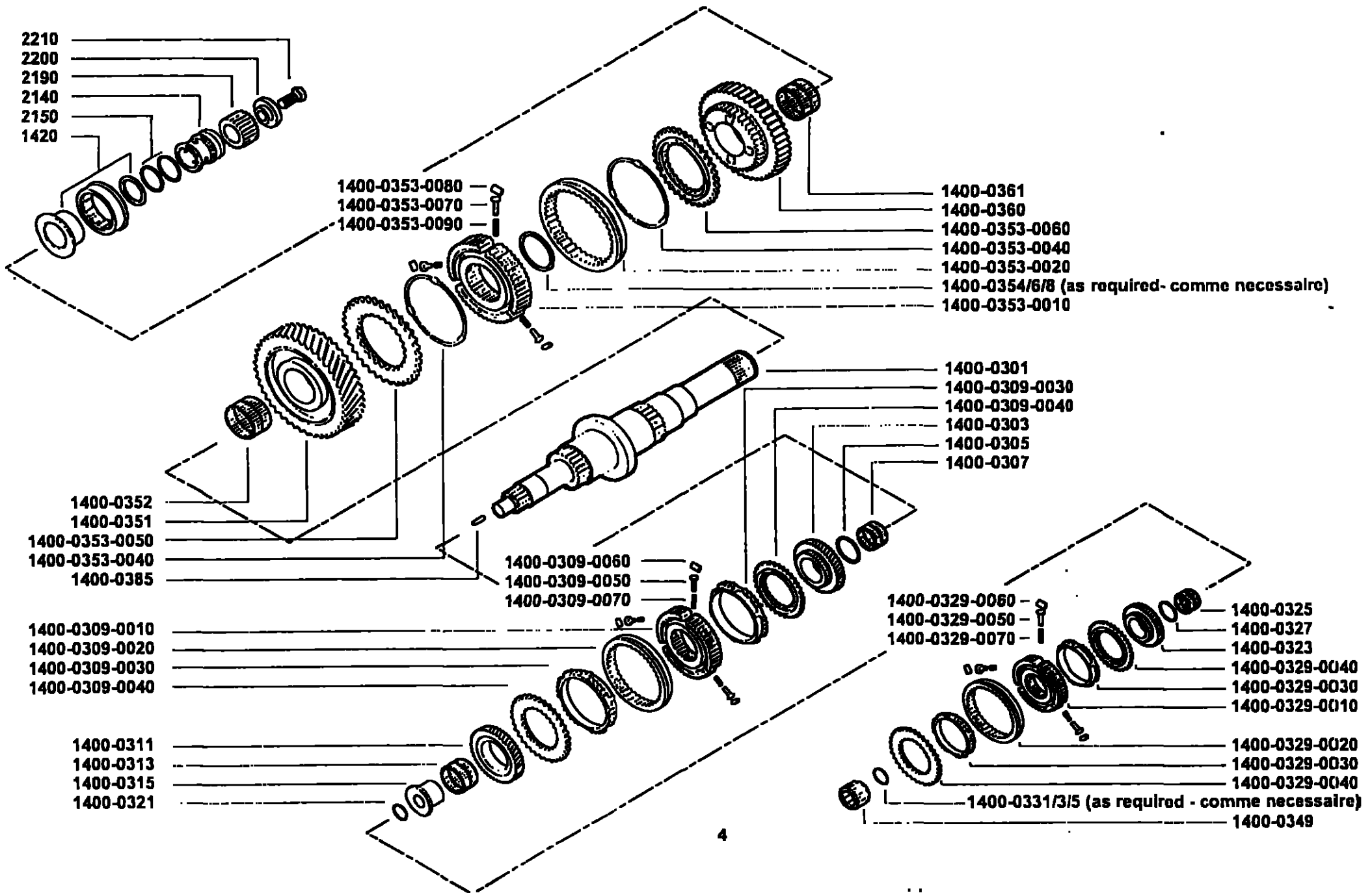

Sequence No	Qty	Part No	English	Deutch	Francaia	Italiano	Espaniol	Stock Qty
1400-0325	1	X8875276 (T20608)	Needle roller bearing	Nadelrollenlager	Roulement a aiguilles	Cuscinetti a rullini	Cojinete de rodillos en aguja	2
1400-0327	1	88752588	Spacer 4th gear	Distanzring 3. Gang	Entretoise 3eme	Distanziale 3a	Separador 3a	2
1400-0329-0010	1	8875554 (T20608)	Fixed hub 3rd/4th	Nabn, feststehend 3/4 gang	Moyeu fixe 3eme/4eme	Mozzo fisso 3/4	Cubo o campana fija 3a/4a	2
1400-0329-0020	1	8875377 (T20608)	Sliding sleeve 2nd/3rd	Schiebemuffe 3/4 gang	Anneau baladeur 3eme/4eme	Manicotto scorrevole 3/4	Casquillo deslizante 3a/4a	2
1400-0329-0030	2	8875135 (T20606)	Synchro ring (T20611)	Synchronring	Anneau de synchro	Anello sincronizzatore	Anillo sincronizador	4
1400-0329-0040	2	8871639 (T20606)	Synchro flange 2nd/3rd-(T20611)	Synchronflansch 3/4 gang	Bride de synchro 3eme/4eme	Flangia sincronizzazione 3/4	Brida de sin. 3a/4a	4
1400-0329-0050	3	8870352 (T20606)	Plunger, synchro	Führungstift	Pionneur	Pistone	Vastago	12
1400-0329-0060	3	X8870356 (T20606)	Roller, synchro	Verriegelungsrolle	Rouleau	Rullo	Rodillo	12
1400-0329-0070	3	8870444 (T20606)	Spring compression	Feder	Ressort	Molla	Muelle	12
1400-0331	1	X8870370 (T20185)	Circlip 40 dia x 2.12mm	Sicherungsring 2.12mm	Circlips 2.12mm	Anello di sicurezza 2.12mm	Anillo elastico 2.12mm	1
1400-0333	1	X8870371 (T20185)	Circlip 40 dia x 2.07mm	Sicherungsring 2.07mm	Circlips 2.07mm	Anello di sicurezza 2.07mm	Anillo elastico 2.07mm	1
1400-0335	1	X8870372 (T20185)	Circlip 40 dia x 2.02mm	Sicherungsring 2.02mm	Circlips 2.02mm	Anello di sicurezza 2.02mm	Anillo elastico 2.02mm	1
1400-0349	1	X8870305 (T20608)	Needle roller bearing	Nadelrollenlager	Roulement a aiguilles	Cuscinetto a rullini	Cojinete de rodillos en aguja	4
1400-0351	1	8878477	Gear mainshaft crawler	Zahnrad K. gang	Pignon, rampante	Ingranaggio, primino	Engranaje bajo	1
1400-0352	1	X8870177 (T20608)	Needle roller bearing	Nadelrollenlager	Roulement a aiguilles	Cuscinetti a rullini	Cojinete de rodillos en aguja	2
1400-0353-0010	1	8875804 (T20616)	Fixed hub-crawler/rev	Nabn, feststehend K.gang/R.gang	Moyeu fixe, rampante/marche arriere	Mozzo fisso, primino/retromarcia	Cubo o campana fija bajo/MA	2
1400-0353-0020	1	8875376 (T20616)	Sliding sleeve- crawler/rev	Scheibemuffe K/R Gang	Anneau baladeur ramp/m AR	Manicotto scorrevole primino/RM	Casquillo deslizante baja MA	2
1400-0353-0030	0		Synchro ring	Synchronring	Anneau de synchro	Anello sincronizzazione	Brida de sin.	1

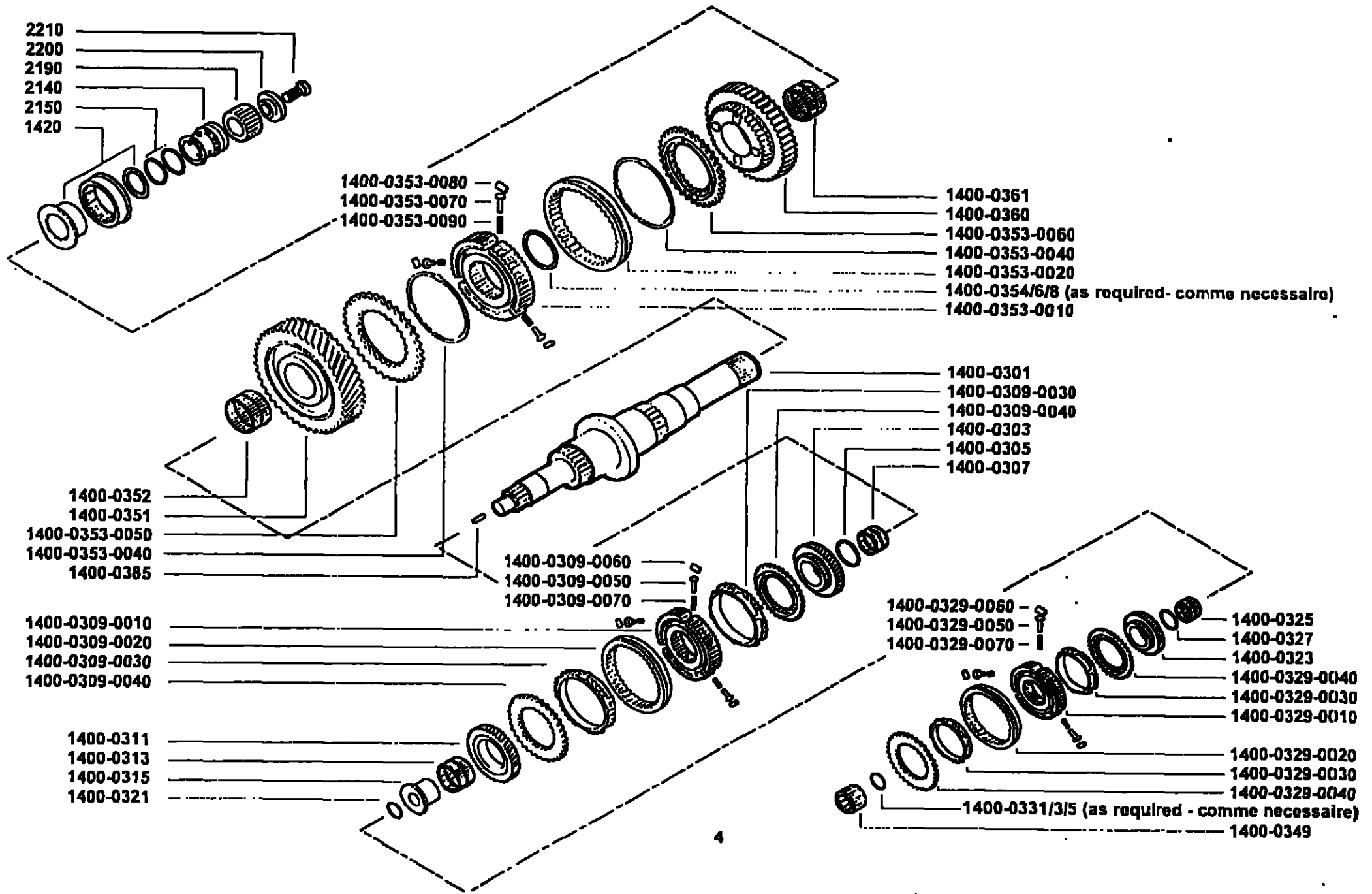

Sequence No	Qty	Part No	English	Deutsch	Francais	Italiano	Espanol	Stock Qty
1400-0353-0040	1	X8873994 (T20616)	Circlip-synchro	Sicherungsring	Circlips	Anello di sicurezza	Anillo elastico	1
1400-0353-0050	1	8876166 (T20616)	Synchro flange 3rd/4th	Synchronflansch K./R. Gang	Bride de synchro rampante/m AR	Flangia sincronizzazione prim/RM	Brida de sin. baja/MA	1
1400-0353-0060	1	8870415 (T20616)	Synchro flange reverse	Synchronflansch R. Gang	Bride de synchro marche AR	Flangia sincronizzatore RM	Brida de sin. MA	1
1400-0353-0070	3	8870352 (T20616)	Plunger, synchro	Führungstift	Plongeur	Pistone	Vastago	3
1400-0353-0080	3	X8870356 (T20618)	Roller synchro	Verriegelungsrolle	Rouleau	Rullo	Rodillo	3
1400-0353-0090	3	8870444 (T20616)	Spring, compression	Feder	Ressort	Molla	Muelle	3
1400-0354	1	X8870378 (T20185)	Circlip 60 dia x 2.10mm	Sicherungsring 2.10mm	Circlips 2.10mm	Anello di sicurezza 2.10mm	Anillo elastico 2.10mm	1
1400-0356	1	X8870379 (T20185)	Circlip 60 dia x 2.05mm	Sicherungsring 2.05mm	Circlips 2.05mm	Anello di sicurezza 2.05mm	Anillo elastico 2.05mm	1
1400-0358	1	X8870380 (T20185)	Circlip 60 dia x 2.00mm	Sicherungsring 2.00mm	Circlips 2.00mm	Anello di sicurezza 2.00mm	Anillo elastico 2.00mm	1
1400-0360	1	8876478	Mainshaft gear reverse	Zahnrad Ruckwärtsgang	Pignon de marche AR	Ingranaggio RM	Engranaje MA	2
1400-0361	1	X8870178 (T20608)	Needle roller bearing	Nadelrollenlager	Roulement a aiguilles	Cuccinetto a rullini	Cojinete de rodillos en aguja	2
1400-0385	1	X14851	Dowel	Stift	Goupille	Alberino	Pasador	2
1400-0386	0		Restrictor	Einstellung	Regulateur	Recoglatore	Adjustaco.	1
1410	0		Thrust washer	Druckscheibe	Rondelle de pousse	Rondella di spinta	Arandela de empuje	2
1420	1	X8877164 (T20608)	Bearing output	Rollenlager	Rolement de sortie	Cuscinetto a rulli	Cojinete de rodillos	2
2140	1	8874921	Oil muff	Ölmuffe	Manchon a huile	Manicotto olio	Manguito aceite	2
2150	2	X8875532	Sealing ring (oil muff)	Öldichtungansch	Joint d'etancheiten	Tenuta dell olio	Reten	2
2190	1	8875585	Gear, sun	Sonnenrad	Satelite	Ingranaggio centrale	Engranaje planetario	1
2200	1	19668	Retainer, sun gear	Halter sonnenrad	Retenue satellite	Fermo ingranaggio centrale	Fiador engranaje planetario	0
2210	1	X8870699	Screw M16 x 45	Schraube	Vis	Vite	Tornillo	0

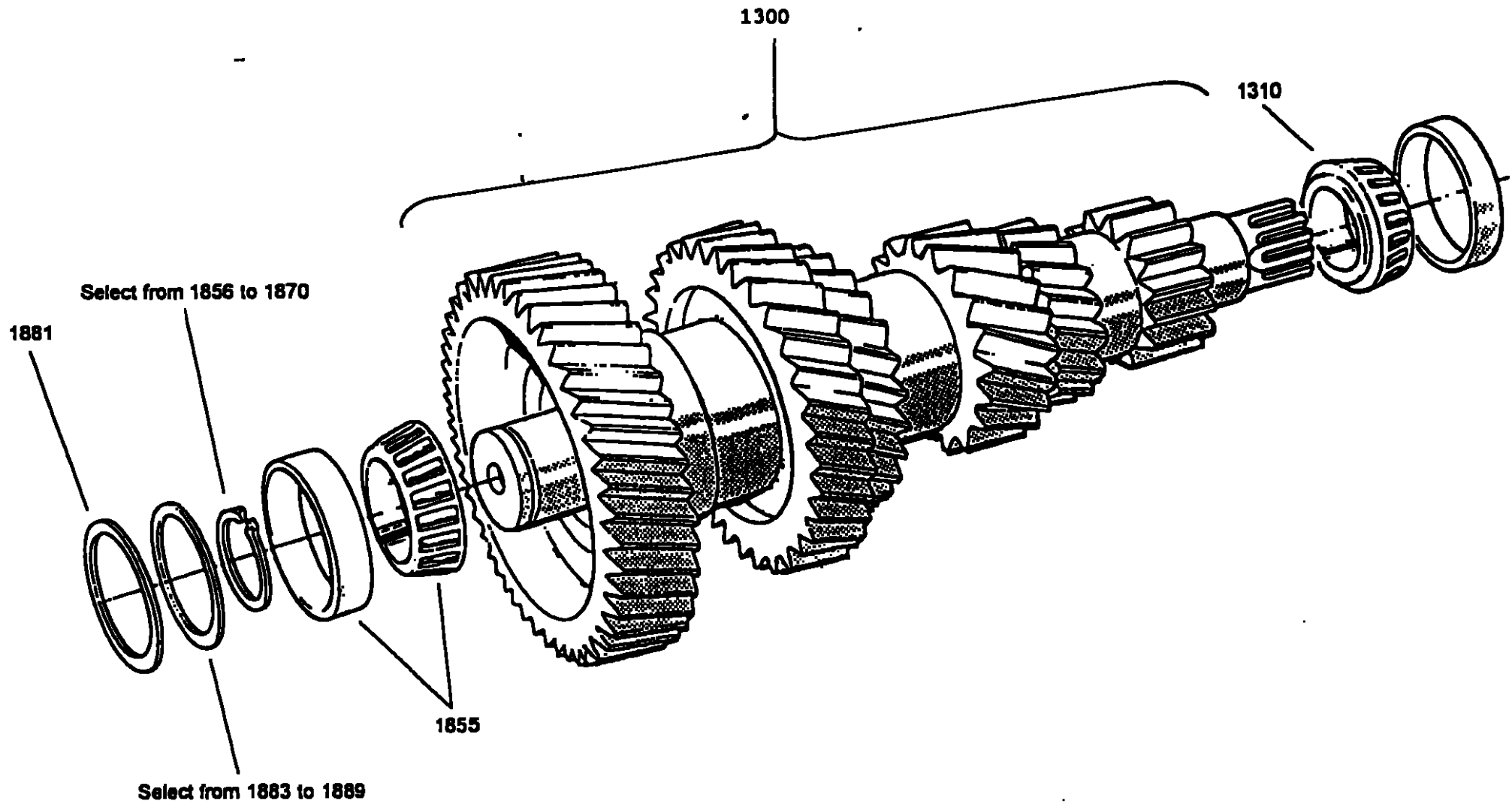

Layshaft Assembly, Vorgelegewelle, Arbre Intermediaire, Complessivo Contralbero, Conjunto Eje Secundario

Section 5

Sequence No	Qty	Part No	English	Deutsch	Francais	Italiano	Espanol	Stock Qty
1300	1	U8875777	Layshaft Assy (Direct)	Vorgelegewelle	Arbre intermediaire	Complessivo contralbero	Conjunto eje secundario	0
1310	1	X8875587 (T20608)	Bearing, taper roller	Kegelrollenlager	Roulement a rouleaux	Cuscinetti a rulli conici	Coninete de rodillos conicos	2
1855	1	X8875587 (T20608)	Bearing, taper roller	Kegelrollenlager	Roulement a rouleaux	Cuscinetti a rulli conici	Coninete de rodillos conicos	2
1856	1	X8870370 (T20185)	Circlip 40 dia x 2.12mm	Sicherungsring 2.12mm	Circlips 2.12mm	Anello di sicurezza 2.12mm	Anillo elastico 2.12mm	1
1858	1	X8870371 (T20185)	Circlip 40 dia x 2.07mm	Sicherungsring 2.07mm	Circlips 2.07mm	Anello di sicurezza 2.07mm	Anillo elastico 2.07mm	1
1860	1	X8870372 (T20185)	Circlip 40 dia x 2.02mm	Sicherungsring 2.02mm	Circlips 2.02mm	Anello di sicurezza 2.02mm	Anillo elastico 2.02mm	1
1862	1	X8871538 (T20185)	Circlip 40 dia x 1.97mm	Sicherungsring 1.97mm	Circlips 1.97mm	Anello di sicurezza 1.97mm	Anillo elastico 1.97mm	1
1864	1	X8871537 (T20185)	Circlip 40 dia x 1.92mm	Sicherungsring 1.92mm	Circlips 1.92mm	Anello di sicurezza 1.92mm	Anillo elastico 1.92mm	1
1866	1	X8871538 (T20185)	Circlip 40 dia x 1.87mm	Sicherungsring 1.87mm	Circlips 1.87mm	Anello di sicurezza 1.87mm	Anillo elastico 1.87mm	1
1868	1	X8871539 (T20185)	Circlip 40 dia x 1.82mm	Sicherungsring 1.82mm	Circlips 1.82mm	Anello di sicurezza 1.82mm	Anillo elastico 1.82mm	1
1870	1	X8871540 (T20185)	Circlip 40 dia x 1.77mm	Sicherungsring 1.77mm	Circlips 1.77mm	Anello di sicurezza 1.77mm	Anillo elastico 1.77mm	1
1881	1	8875879 (T20344)	Spacer 2.5/2.3mm	Distanzring 2.5/2.3mm	Entretoise 2.5/2.3mm	Distanziale 2.5/2.3mm	Separador 2.5/2.3mm	1
1883	1	F88891 (T20344)	Shim 0.051mm	Distanzring 0.051mm	Entretoise 0.051mm	Distanziale 0.051mm	Separador 0.051mm	1
1885	1	F88892 (T20344)	Shim 0.127mm	Distanzring 0.127mm	Entretoise 0.127mm	Distanziale 0.127mm	Separador 0.127mm	1
1887	1	F88893 (T20344)	Shim 0.254mm	Distanzring 0.254mm	Entretoise 0.254mm	Distanziale 0.254mm	Separador 0.254mm	1
1889	1	F88894 (T20344)	Shim 0.510mm	Distanzring 0.510mm	Entretoise 0.510mm	Distanziale 0.510mm	Separador 0.510mm	1

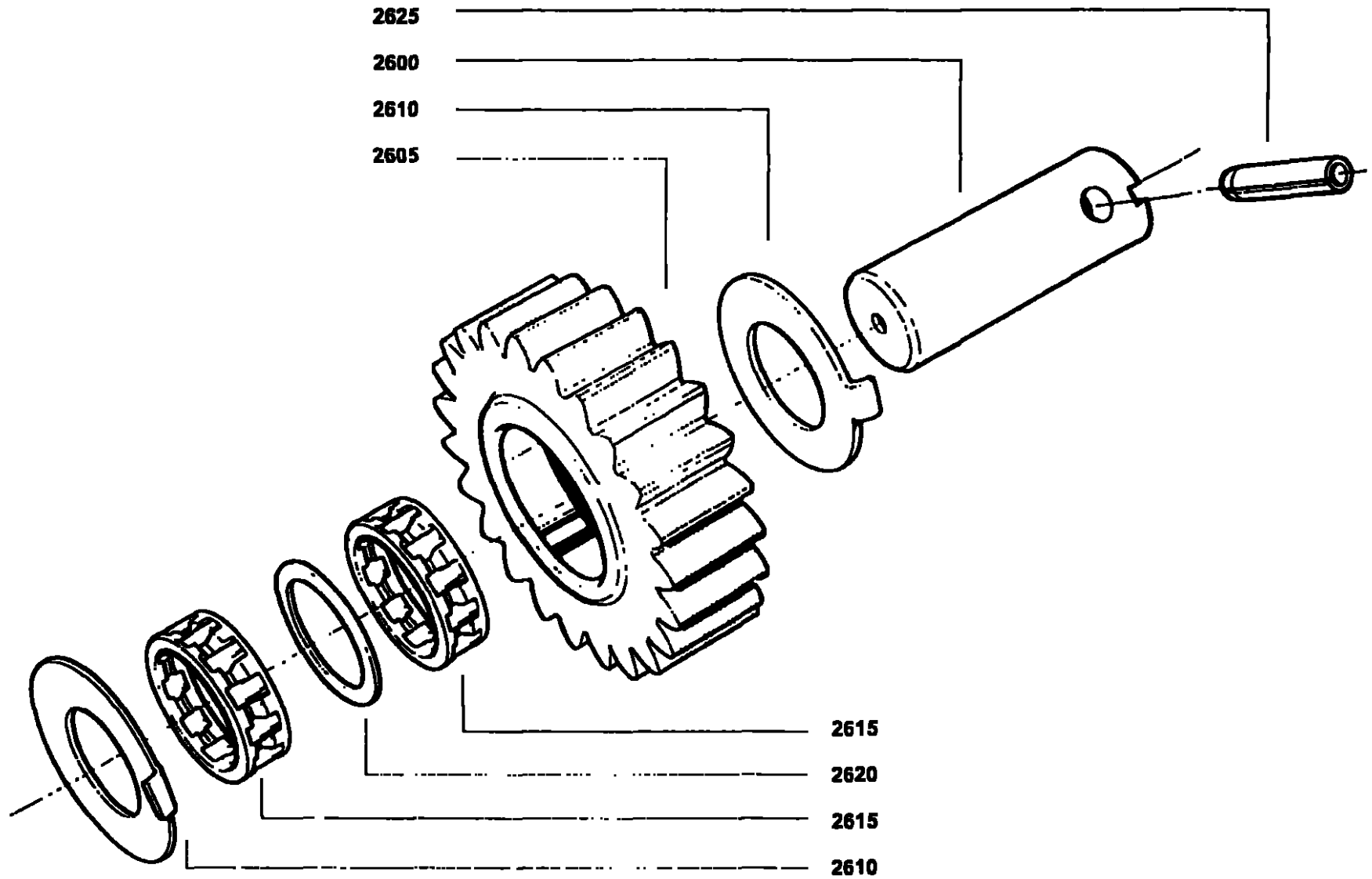

Reverse Idler Gear Assembly, Ruckwartsgang-Unkehrad, Pignon de Renvoi-Marche AR, Ingranaggio Rinvio Rm, Conjunto Inversor MA
Section 6

Sequence No	Qty	Part No	English	Deutsch	Francais	Italiano	Espanol	Stock Qty
2600	1	8872779	Shaft, reverse idler	Welle	Axe de pignon de renvoi de marche AR	Albero ingranaggio rinvio RM	Eje intermedio de MA	1
2605	1	8876457	Gear, reverse idler	Zahnrad	Pignon de renvoi de marche AR	Ingranaggio rinvio RM	Pinon intermedio de MA	1
2610	2	8870343	Thrust washer, rev idler	Druckscheibe	Rondelle de pousse	Rondella di spinta	Arandela de empuje	2
2615	2	X8872478 (T20608)	Needle roller bearing	Nadelrollenlager	Roulement a aiguilles	Cuscinetti a rulli	Conjunte de rodillos en aguja	4
2620	1	8872479	Spacer, rev idler brg	Distanzring	Entretoise	Distanziale	Separador	0
2625	1	X8873729	Parallel groove pin	Spannstift	Goupille rainuree	Alberino	Pasador	1

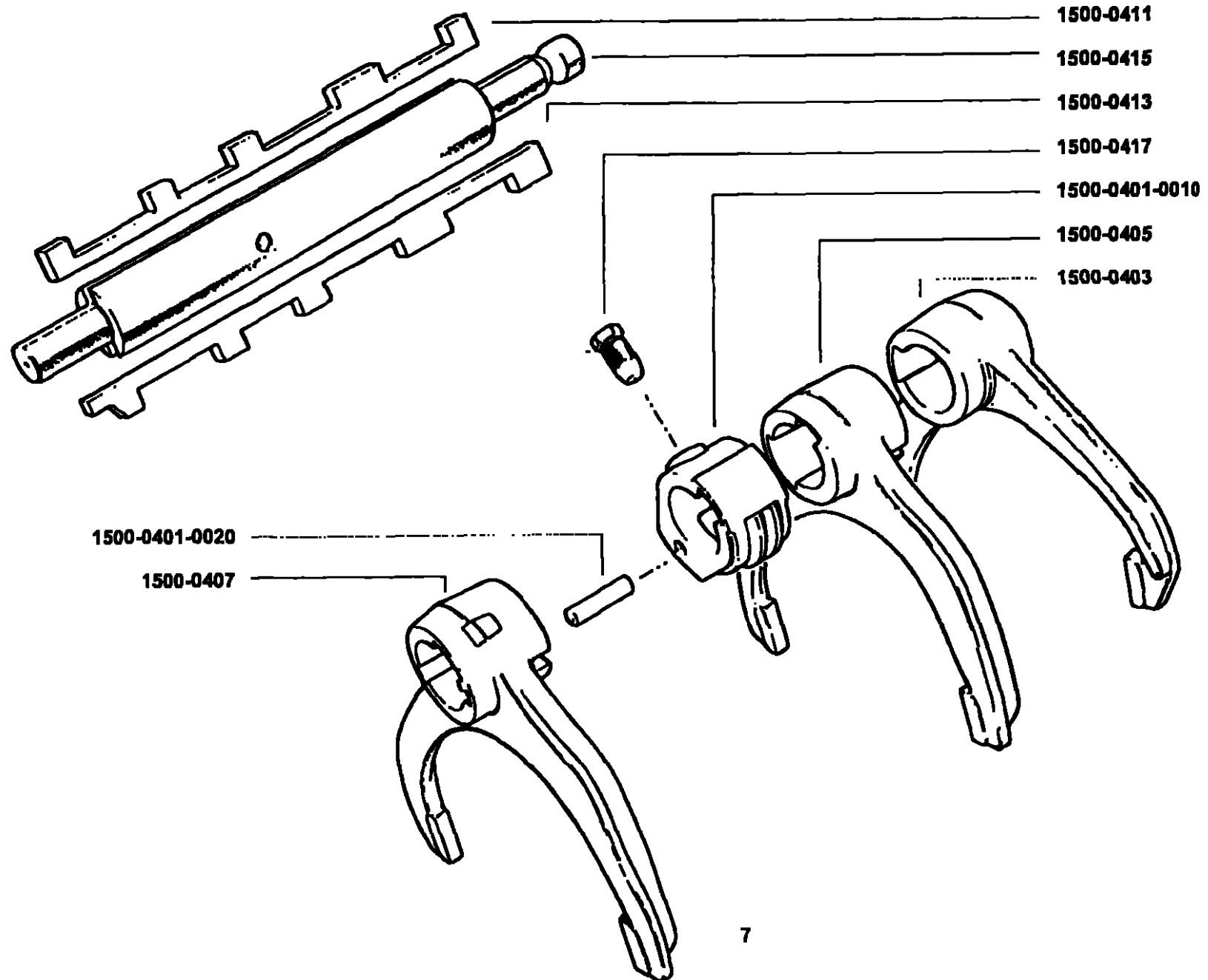

Sequence No	Qty	Part No	English	Deutsch	Francais	Italiano	Espanol	Stock Qty
1500	Ref	U8875941	Selector assy. vert.	Schaltblock	Bloc de selection	Blocco selezione	Bloque selector	1
1500-0401	1	U8875948	Selector block assy	Schaltblock	Bloc de selection	Blocco selezione	Bloque selector	1
1500-0401-0010	1	8874754	Selector block	Schaltblock	Bloc de selection	Blocco selezione	Bloque selector (Padir U8875960)	0
1500-0401-0020	1	X8870277	Dowel	Stift	Goupille	Alberino	Pasador	1
1500-0403	1	8875496	Selector fork crawler/rev	Schaltgabel K./R. Gang	Fourchette de selection rampante/marche AR	Forcella cambio primino/RM	Horquilla cambio baja/MA	1
1500-0405	1	8875495	Selector fork 1st/2nd	Schaltgabel 1./2. Gang	Fourchette de selection 1eme/2eme	Forcella cambio 1'/2'	Horquilla cambio 1a/2a	2
1500-0407	0		Overdrive selector	Schaltblock (Schnellgang)	Selecteur (Surmultipliee)	Selettore (Surmoltiplicata)	Selector (Superdirecta)	2
1500-0407	1	8875494	Selector fork 3rd/4th	Schaltgabel 3./4. Gang	Fourchette de selection 3eme/4eme	Forcella cambio 3/4	Horquillo cambio 3a/4a	2
1500-0411	1	8872328	Selector key	Schaltklinke	Reglette de selection	Chiavetta selettore	Llave selectora	1
1500-0413	1	8872327	Interlock key	Vernegelungsklinke	Reglette de verrouillage	Chiavetta bloccaggio interdipendente	Llave interenclavamiento	1
1500-0415	1	8875827	Selector shaft ("H")	Schaltachse ("H")	Axe de selecteur ("H")	Chiavetta selettore ("H")	Llave selectora ("H")	1
1500-0417	1	8873691	Location screw	Schraube	Vis	Vite	Tornillo	1
1700			Overdrive fork	Schaltgabel (schnellgang)	Fourchette de selection (surmultipliee)	Forcella cambio (Surmoltiplicata)	Horquilla cambia (superdirecta)	1
1710			Shift pad	Schaltbacken	Coussin	Cuscinetto	Taco	2
1720			Rotation pin	Stift	Goupille	Alberino	Pasador	2

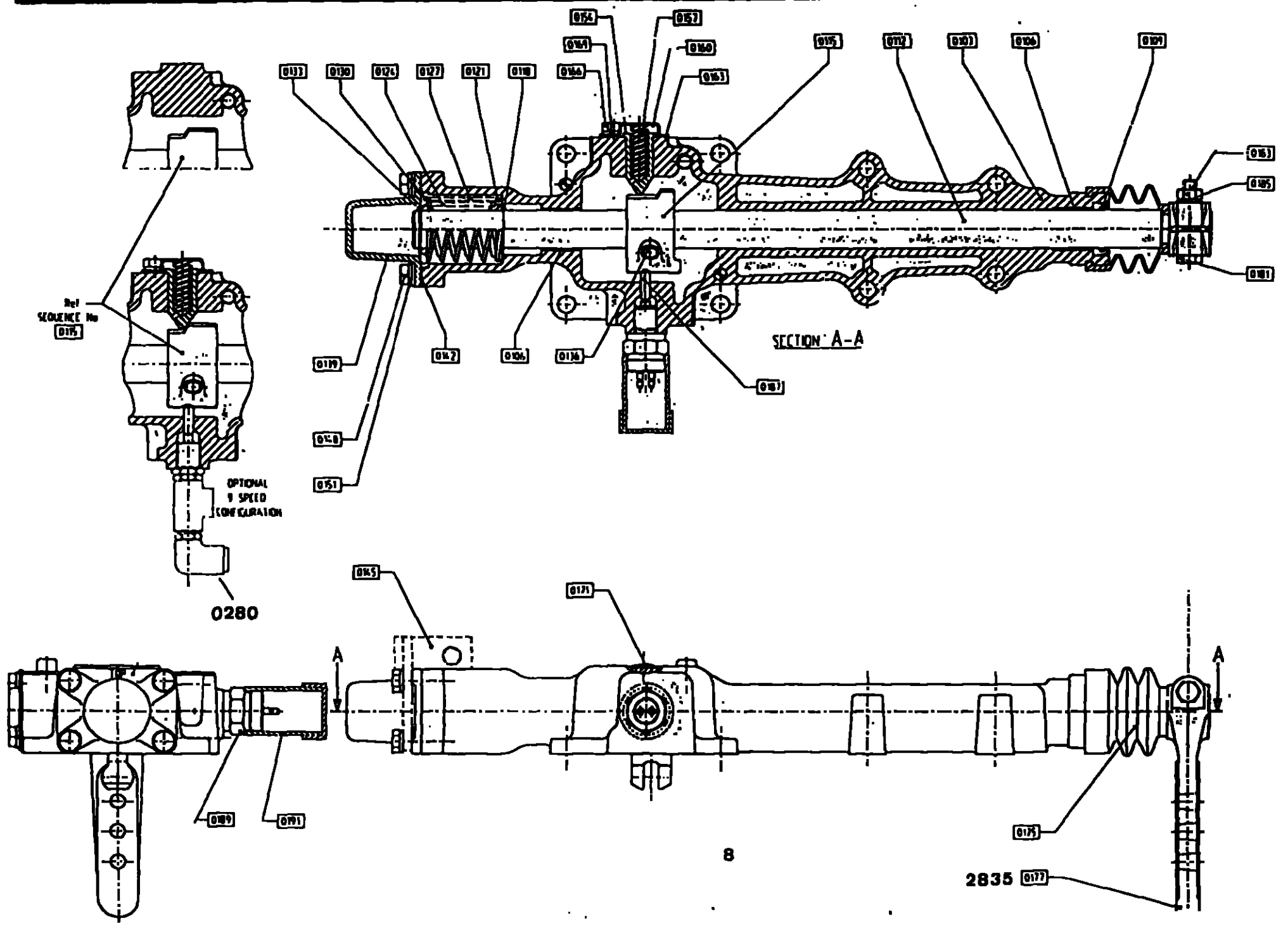

Sequence No	Qty	Part No	English	Deutsch	Francais	Italiano	Espanol	Stock Qty
2700	Ref	U8874752	LRC Assy LH vert.	Gehäuse (Linkslenker)	Corps (Gauche)	Scatola (sinistra)	Envuelta (izq.)	0
2700-0103	1	8874744	Housing LRC (LH)	Gehäuse (Linkslenker)	Corps (gauche)	Scatola (sinistra)	Envuelta (izq.)	1
2700-0106	2	X8871377	Bush cross shaft	Buchse	Bague axe transversal	Boccola	Casquillo	4
2700-0109	1	X8871394 (T20609)	Oil seal-cross shaft	Oldichtring	Joint d'huile axe transversal	Tenuta olio	Reten eje transversal	2
2700-0112	1	8874797	Cross shaft LH	Schaltwelle	Axe transversal	Albero trasversale	Eje transversal	1
2700-0118	1	X8874450	Circlip external	Sicherungsring	Circlips	Anello di sicurezza	Anillo elastico	1
2700-0121	1	8876566	Spring retainer	Federfuhung	Retenue de ressort	Retenzione di molla	Retencion con resorts	1
2700-0130	1	8876567	Spring retainer	Federfuhung	Retenue de ressort	Retenzione di molla	Retencion con resorts	0
2700-0133	1	X8874450	Circlip, external	Sicherungsring	Circlips	Anello di sicurezza	Anillo elastico	1
2700-0136	1	X8871378	Parallel grooved pin	Spanstift	Goupille a rainures paralleles	Alberino scanalato	Pascador acanalado en paralelo	1
2700-0138	1	8876041	End cover	Deckel	Couvercle	Coperchio	Tapa	0
2700-0142	1	8873734 (T20609)	Gasket, end cover	Dichtung	Joint	Guarnizione	Junta	2
2700-0151	4	MX-3-0801	Spring washer M8	Federring M8	Rondelle grower M8	Rosetta elastica M8	Arandela elastica M8	0
2700-0154	1	8875415	Detent plunger	Kolben	Plongeur de verrouillage	Pistone d'arresto	Pestillo de retenida	1
2700-0157	1	8870587	Spring, compression	Feder	Ressort de compression	Molla compressione	Resorte de compresion	1
2700-0160	1	8870259	Detent cover	Deckel	Couvercle de verrouillage	Coperchio d'arresto	Tapa de retenida	0
2700-0163	1	8870590 (T20609)	Gasket	Dichtung	Joint	Guarnizione	Junta	1
2700-0166	2	MX-8-0801	Screw M8 x 14	Schraube M8 x 14	Vis M8 x 14	Vite M8 x 14	Tornillo M8 x 14	0
2700-0169	2	MX-3-0801	Spring washer M8	Federring M8	Rondelle grower M8	Rosetta elastica M8	Arandela elastica M8	-
2700-0171	1	X8871486	Plug, expansion	Verschlusschraube	Bouchon de dilation	Tappo-dilatazione	Tapon expansor	1
2700-0175	1	X8875259	Boot	Faltenblag	Manchon protecteur	Manicotto de gomma	Manillar de acucho	1
2700-0176	-	X8877790	LOCTITE 5205	LOCTITE 5205	LOCTITE 5205	LOCTITE 5205	LOCTITE 5205	-

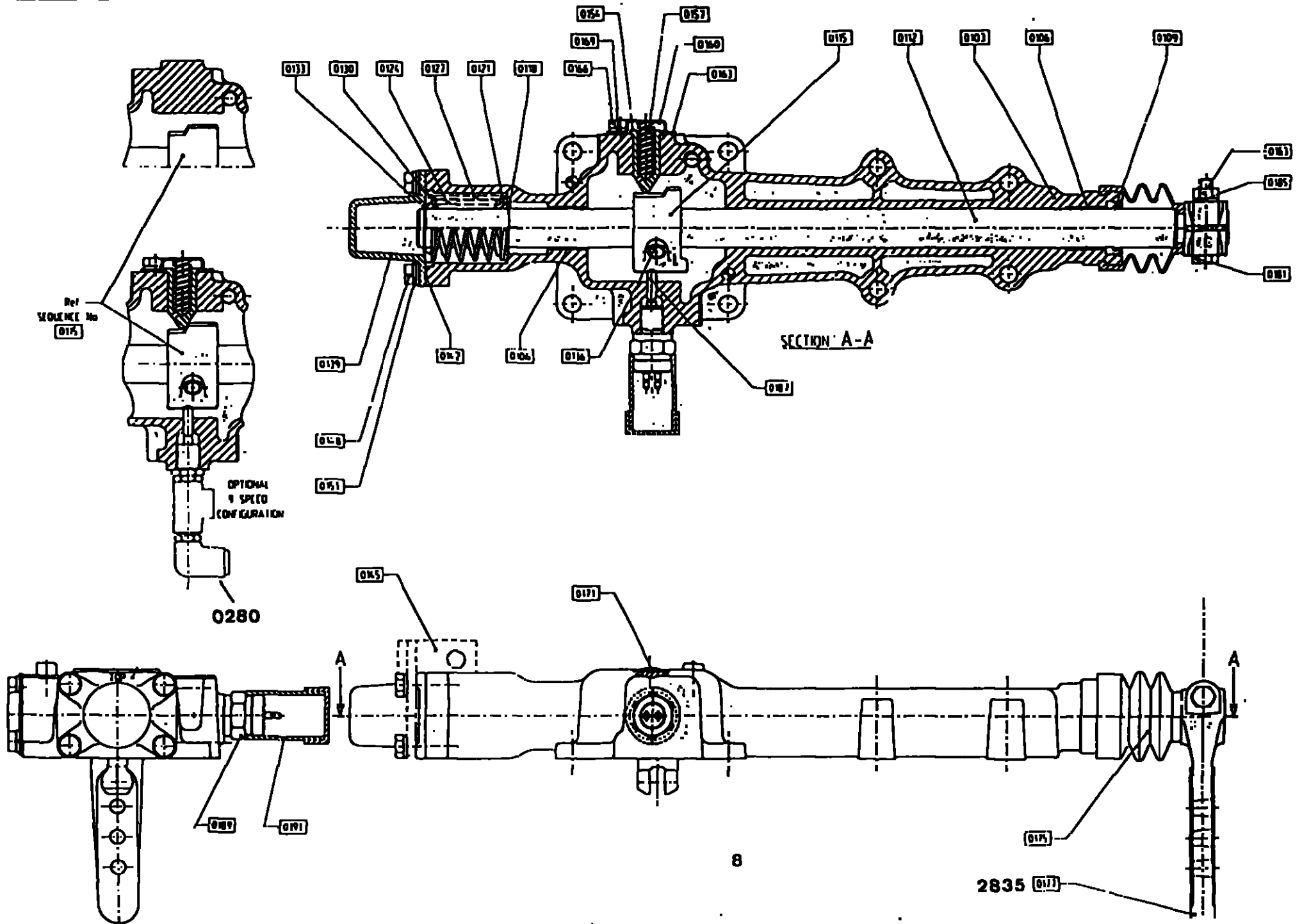

Sequence No	Qty	Part No	English	Deutsch	Francais	Italiano	Espanol	Stock Qty
2700-0115 (2805)	1	8877656	Inner striking lever (H)	Schaltfinger (H)	Embrayeur interieur (H)	Lava battente interna (H)	Palanca de contacto interior (H)	1
2700-0124 (2810)	1	8871395	Spring, compression	Feder	Ressort de compression	Molla compressione	Resorte de compression	1
2700-0127 (2815)	1	8876345	Spring, booster	Feder	Ressort de compression	Molla compressione	Resorte de compression	1
2700-0148 (2825)	4	MX-8-0803	Screw M8 x 25	Schraube M8 x 25	Vite M8 x 25	Vite M8 x 25	Tornillo M8 x 25	0
2700-0173 (2830)	1	X2014210	Breather	Entlufner	Renflard	Sfiatatoio	Respiro	2
2700-0177 (2835)	1	8876063	Outer lever	Hebel	Levier exterieur	Lava esterne	Palanquita exterior	1
2700-0181 (2845)	1	MX-8-1007	Bolt M10 x 50	Sechskantschraube M10	Boulon M10 x 50	Bullone M10 x 50	Perno M10 x 50	0
2700-0183 (2850)	1	MX-9-1001	Nut M10 x 1.5	Mutter M10 x 1.0	Ecrou M10 x 1.0	Dado M10 x 1.0	Tuerca M10 x 1.0	0
2700-0185 (2855)	1	MX-3-1001	Spring washer M10	Federring M10	Rondelle grower M10	Rosetta elastica M10	Arandela elastica M10	0
2700-0187 (2860)	1	8871375	Actuator pin	Stift	Goupille	Alberino	Passador	1
2900-0280	1	X8877766	Poppet valve	Ventil	Valve	Valvola	Valvula	1

Planet Carrier Assembly, Planetenradytrager, Porte-planetaire, Complessivo Scaola Satelliti, Conjunto del Portapinon Satellite Section 10

Sequence No	Qty	Part No	English	Deutsch	Francais	Italiano	Espanol	Stock Qty
2300-0917	Ref	U8876456	Output shaft assembly	Abtriebswelle komplet	Arbre de sortie assemble	Albero uscita complessivo	Eje secundario conjunto	-
2300-0917-0010	1	U8876689	Planet gear assy					1
2300-0917-0010-0020	5	8875586	Gear, planet	Planetenrad	Pignon planetaire	Ingranaggi satelliti	Engranaje planetario	5
2300-0917-0010-0030	5	8872682	Planet gear spindle	Planetenradspindel	Fuseau de pignon planetaire	Alberino ingranaggi satelliti	Eje de engranaje planetario	5
2300-0917-0010-0040	5	U8875235 (T20275)	Needle roller assembly	Nadelrollenlager	Roulement a aiguilles	Cuscinetti a rullini	Cojinetes de rodillos en aguja	5
2300-0917-0010-0040-0020	5	8872741	Spacer	Distanzstueck	Entretoise	Distanziale	Separador	0
2300-0917-0010-0040-0030	10	8874827	Thrustwasher	Druckscheibe	Rondelle de poussee	Rondella di spinta	Arandela de empuje (Pedir U8875235)	0
2300-0917-0010-0070	5	MX-11-0601 (T20275)	Screw, grub	Schraube	Vis	Vite	Tornillo	0
2300-0917-0010-0080	10	8876893 (T20275)	Thrustwasher	Druckscheibe	Rondelle de poussee	Rondella di spinta	Arandela de empuje	10

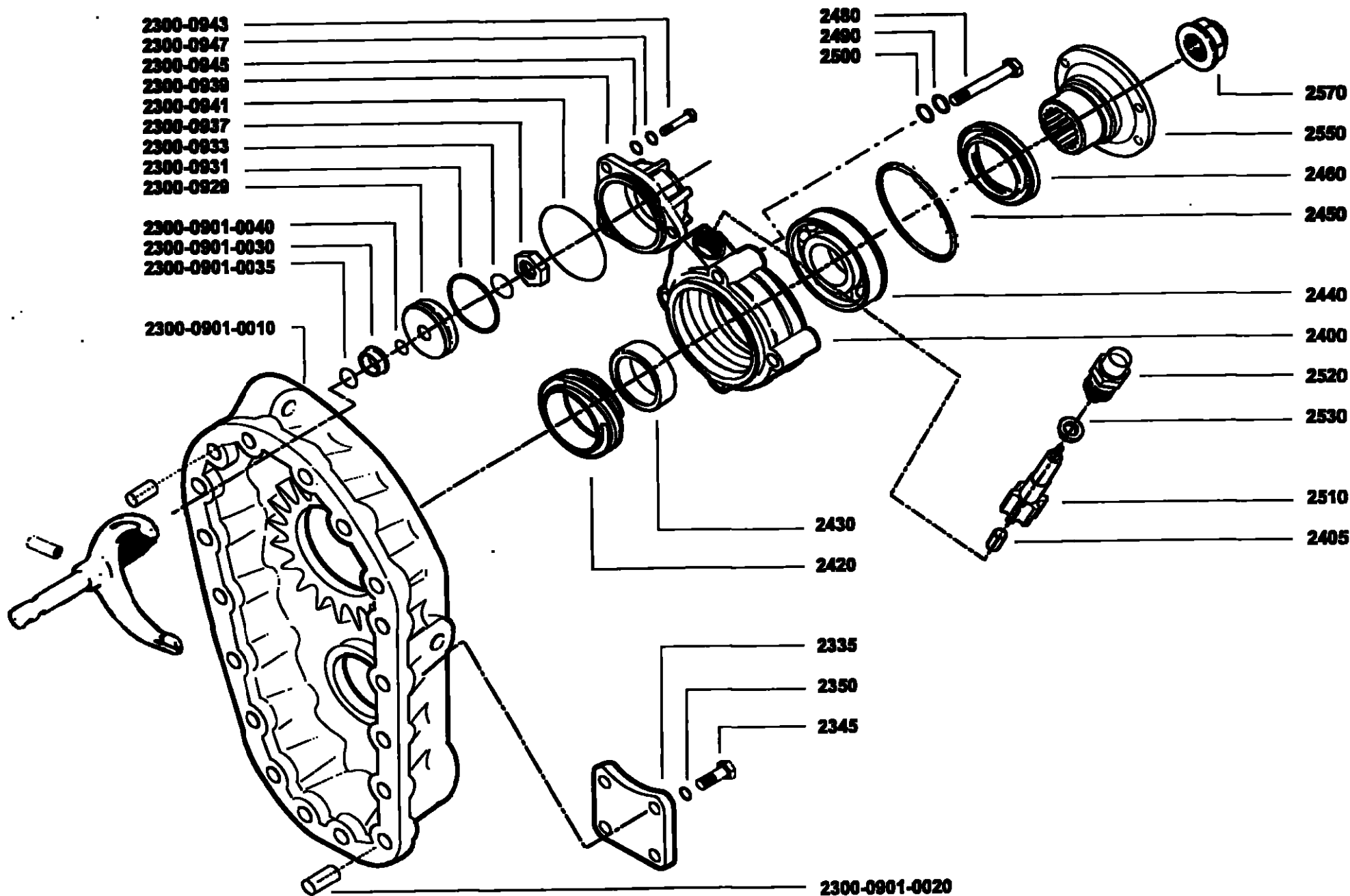

Rear Case Assembly, Hinteres Gehäuse, Carter Arriere, Scatola Posteriore, Tapa Trasera

Section 11

Sequence No	Qty	Part No	English	Deutsch	Francais	Italiano	Espanol	Stock Qty
2300	Ref	U8876455	Rear housing assy	-	-	-	-	-
2300-0901	1	U8874395	Rear case assy.-vert.	Hinteres gehause	Carter AR	Scatola posteriore	Tapa trasera	0
2300-0901-0010	1	8874367	Rear case	Hinteres gehause	Carter AR	Scatola posteriore	Tapa trasera	0
2300-0901-0020	2	X8870543	Dowel 16 dia x 30	Passstift	Goupille	Grano di riferimento	Espiga	2
2300-0901-0030	1	8875293	Bush	Buchse	Bague	Boccola	Casquillo	2
2300-0901-0035	1	X8875292 (T20609)	"O" ring	"O" ring	Joint torique	Guarnizione toroidale	Junta torica	1
2300-0901-0037	-	X14153	LOCTITE 641 yellow	LOCTITE 641 gelb	LOCTITE 641 jaune	LOCTITE 641 giallo	LOCTITE 641 amarillo	0
2300-0901-0040	1	X8871258 (T20609)	"O" ring	"O" ring	Joint torique	Guarnizione toroidale	Junta torica	4
2300-0929	1	8875179	Piston, range	Kolben	Piston	Stantuffo	Piston	1
2300-0931	1	14344 (T20183)	"O" ring range piston	"O" ring	Joint torique	Guarnizione toroidale	Junta torica	4
2300-0933	1	14345 (T20183)	"O" ring range bar	"O" ring	Joint torique	Guarnizione toroidale	Junta torica	4
2300-0935	-	71203	Silicone lubricant	Silikonschmiermittel	Lubrifiant au silicone	Lubrificante silconico	Silicona lubricante	0
2300-0937	1	MX-9-1602 (T20183)	Nut M16	Mutter M16	Ecrou M16	Dado M16	Tuerca M16	0
2300-0938	-	X14177	Nutlock	Nutlock	Nutlock	Nutlock	Nutlock	-
2300-0939	1	8875430	Cylinder range	Kolben	Cylindre	Cilindro	Cilindro	0
2300-0941	1	X8873008 (T20183)	"O" ring range cover	"O" ring	Joint torique	Guarnizione toroidale	Junta torica	4
2300-0943	3	MX-8-1067	Bolt M10 x 60	Schraube M10 x 60	Boulon M10 x 60	Vite M10 x 60	Tornillo M10 x 60	0
2300-0945	3	X11245	Washer M10	Scheibe M10	Rondelle M10	Rondella M10	Arandela M10	0
2300-0947	3	MX-3-1001	Spring washer M10	Fnderring M10	Rondelle grower M10	Rosetta elastica M10	Arandela elastica	0
2335	1	8873917	Rear PTO cover	Deckel	Couvercle AR	Coperchio	Tapa	0
2340	-	X8877790	LOCTITE 5205	LOCTOITE 5205	LOCTITE 5205	LOCTITE 5205	LOCTITE 5205	-
2345	4	MX-8-1209	Screw M12 x 25	Schraube M10 x 25	Vis M10 x 25	Vite M10 x 25	Tornillo M10 x 25	0

Rear Case Assembly, Hintores Gehäuse, Carter Arriere Assemblee,
Complesivo Scatola Anteriore, Conjunto Tapa Trasera

6109/8209

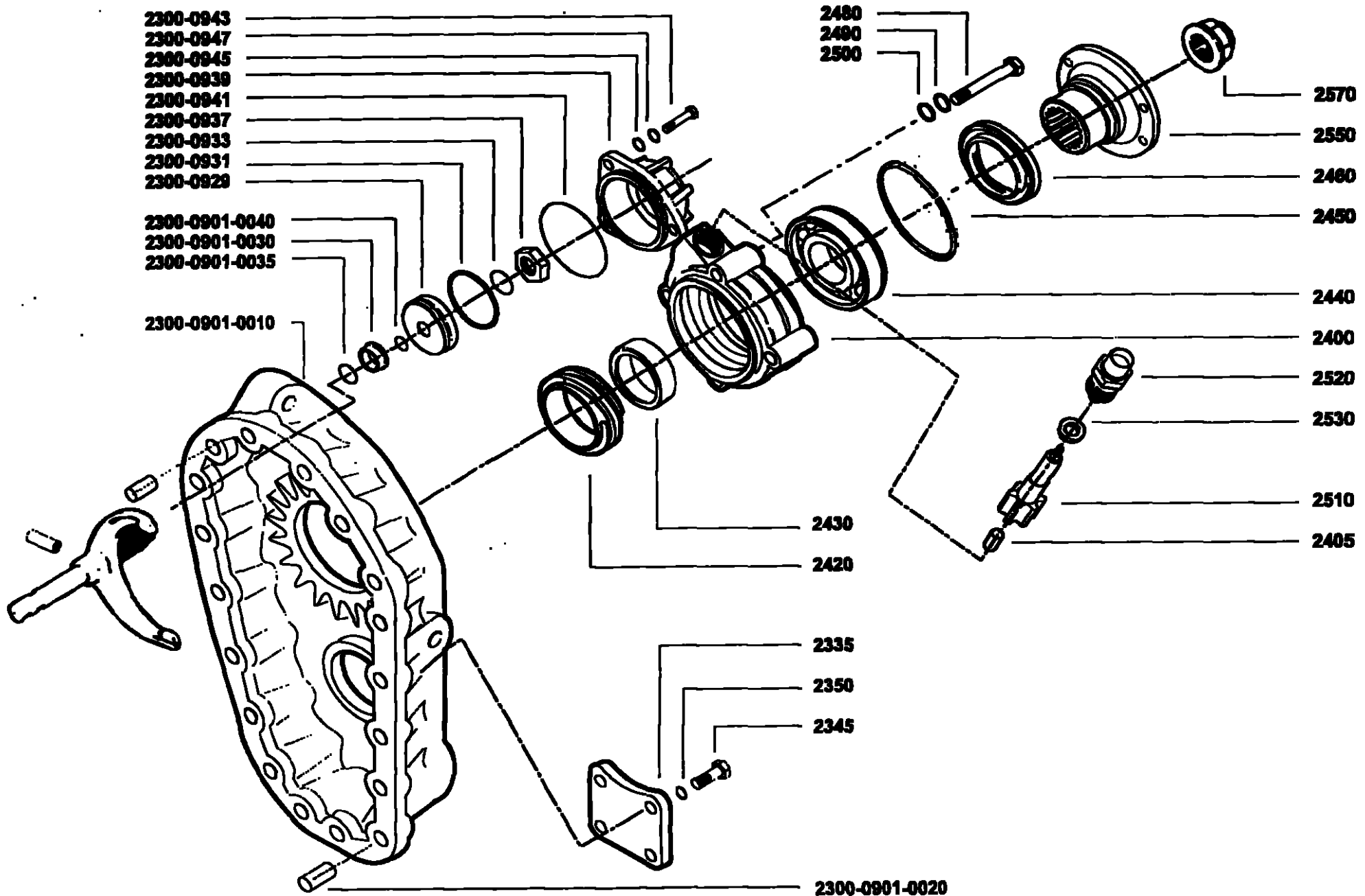

Sequence No	Qty	Part No	English	Deutsch	Francais	Italiano	Espanol	Stock Qty
2350	4	MX-3-1201	Spring washer M12	Federring M12	Rondelle grower M12	Rosetta elastica M12	Arandela elastica M12	0
2400	1	8875611	Speedo housing	Tachometergehäuse	Boitier de tachymetre	Scatola indicatore velocita	Envuelta del velocimetro	0
2405	1	7992	Bush	Buchse	Bague	Boccola	Casquillo	2
2410	-	X8877790	LOCTITE 5205	LOCTITE 5205	LOCTITE 5205	LOCTITE 5205	LOCTITE 5205	-
2420	1	8876084	Speedo drive gear-6T	Tachoschnecke	Pignon de compteur de vitesse	Ingranaggio comando marce	Engranje conductor del velocimetro	1
2430	1	8873918	Spacer-rotor	Distanzstueck-rotor	Entretoise-rotor	Distanziale-rotor	Separador-rotor	0
2440	1	X8872721 (T20608)	Bearing	Lager	Roulement	Rullo	Rodillo	2
2450	1	8875614	Circlip-internal	Sichersrungsring	Circlips	Anello elastica	Arandela elastica	1
2460	1	X8875615 (T20609)	Oil seal	Oldichtung	Joint d'etancheite	Tenuta olio	Reten de aceite	4
2470	-	X8877790	LOCTITE 5205	LOCTITE 5205	LOCTITE 5205	LOCTITE 5205	LOCTITE 5205	-
2480	4	MX-8-1037	Screw M10 x 100	Schraube	Vis	Vite	Tornillo	-
2490	4	MX-3-1001	Spring washer M10	Federring	Rondelle grower	Rosetta elastica	Arandela elastica	-
2510	1	8874006	Speedo pinion	Tachometerritzel	Pignon de tachymetre	Pignone tachimetro	Pinon de veloc.	1
2520	1	8874007	Adaptor	Adapter	Adaptateur	Addatore	Adaptador	1
2530	1	X11603	Washer M22	Scheibe, Kupfer	Rondelle	Rondella	Arandela	2
2545	0		Abutment ring	Ring-	Segment-	Anello-	Anillo-	-
2550	1	8875613	Output flange	Abtriebsflansch	Bnde de sortie/fourchette	Forcella flangia uscita	Brida salida/horquilla	0
	OR							
2550	0		Yoke-Dana Spicer	Schaltgebel	Fourchette	Forcella	Horquilla	-
2560	0		Thrust washer	Druckscheibe	Rondelle de poussee	Rondella di spinta	Arandela de empuje	-
2570	1	X8870553	Nyloc nut M39	Mutter Nyloc	Ecrou, Nyloc	Dado, Nyloc	Tuerca, Nyloc	2

Range Synchroniser Assembly, Synchron-schalt, Synchro-selection de Gamme,
Synchronizzatore-selattore, Sincronizador-selectora gama

- 2300-0917-0080-0030
- 2300-0917-0090
- 2300-0917-0080-0040
- 2300-0917-0080-0100

- 2300-0917-0080-0010
- 2300-0917-0080-0040

- 2300-0917-0080-0020
- 2300-0917-0120
- 2300-0917-0110
- 2300-0911
- 2300-0915
- 2300-0913

- 2300-0917-0080-0030
- 2300-0917-0100
- 2300-0917-0080-0060

- 2300-0917-0080-0080
- 2300-0917-0080-0070
- 2300-0917-0080-0090

- 2300-0909
- 2300-0907
- 2300-0903
- 2300-0917-0080-0050
- 2300-0905
- 2300-0902

2300 0901 0010

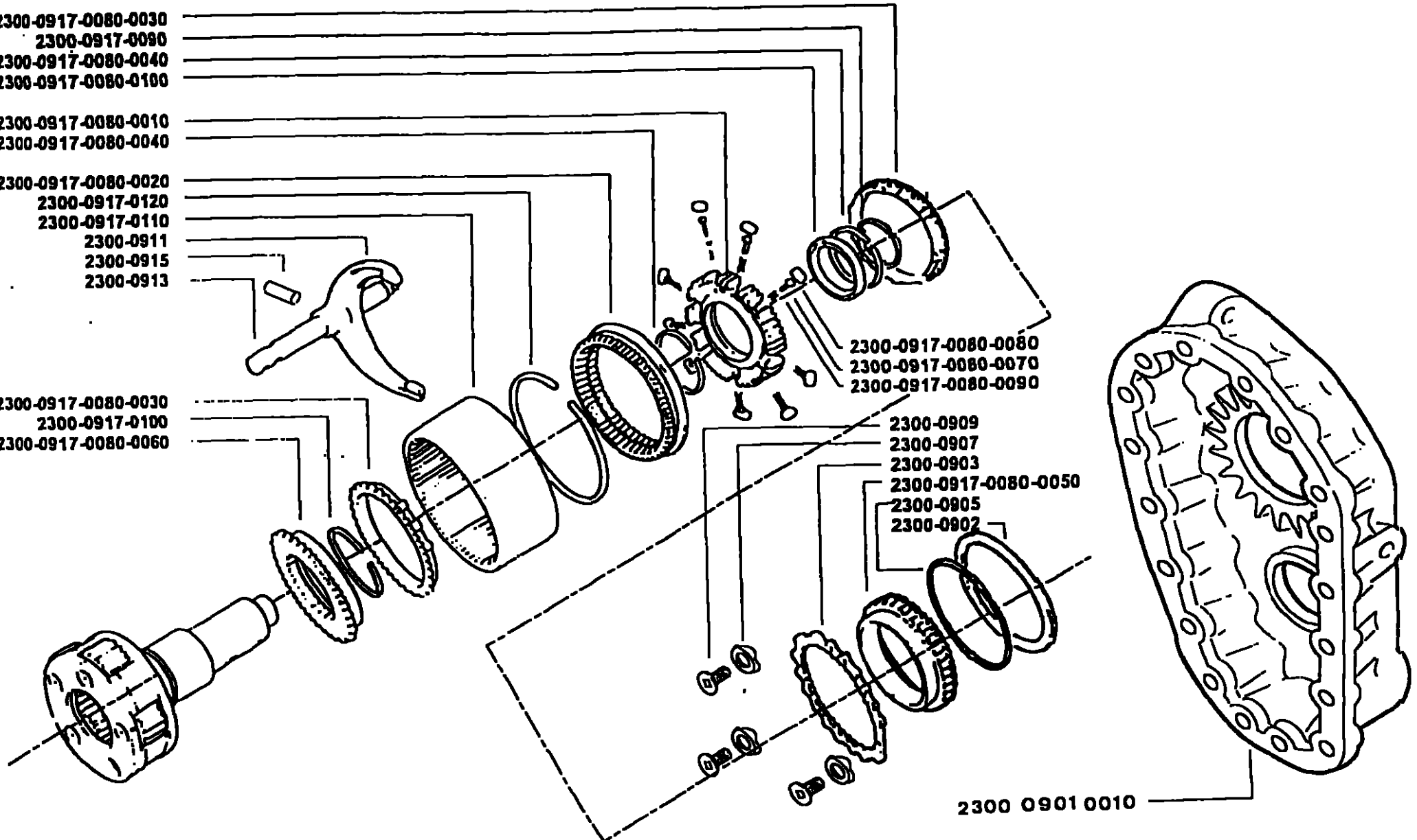

Range Synchronizer Assembly, Synchron-schalt, Synchro-selecteur, Sincronizzatore-selattore, Sincronizador-selector gama Section 12

Sequence No	Qty	Part No	English	Deutsch	Francés	Italiano	Español	Stock Qty
2300-0902	1	8870808	Spacer	Distanzring	Entretoise	Distanziale	Separador	0
2300-0903	1	8875646	Reaction plate	Reaktionsscheibe	Plaque de reaction	Piastra di reazione	Placa de reaccion	1
2300-0905	1	X8873993	Circlip	Sicherungsring	Circlips	Anello di sicurezza	Anillo elastico	1
2300-0907	3	8870848	Reaction plate retainer	Halter für reaktionsscheibe	Retenue de plaque de reaction	Fermo piastra di reazione	Placa de reaccion	0
2300-0909	3	MX-8-0806	Screw M8 x 20	Schraube M8x20	Vis M8x20	Vite M8x20	Tornillo M8x20	
2300-0911	1	8872737	Range shift fork	Schaltgabel	Fourchette de selection de gamme	Forcella cambio	Horquilla cambio gamas	2
2300-0913	1	8872626	Range shift rod	Schaltstange	Axe du selecteur	Chiovetta selettore	Llave selectora gamas	1
2300-0915	1	X8870728	Grooved pin	Spannstift	Goupille rainuree	Albenno scanalato	Pasador con muescas	2
2300-0917-0080-0010	1	8875881 (T20607)	Fixed hub, synchro range	Nabe, feststehend	Moyeu fixe synchro gamme	Mozzo fisso sincronizzatore	Cubo o campana fija	2
2300-0917-0080-0020	1	8873041 (T20607)	Sliding sleeve, range	Schiebermuffe	Anneau baladeur, gamme	Manicotto scorrevole	Casquillo deslizante	2
2300-0917-0080-0030	2	8875183 (T20607)	Synchro ring, range (T20613)	Synchronring	Anneau de synchro, gamme	Anello sincronizzazione	Anillo sincronizador	4
2300-0917-0080-0040	2	X8870341 (T20607)	Circlip	Sicherungsring	Circlips	Anello di sicurezza	Anillo elastico	1
2300-0917-0080-0050	1	8874037 (T20607)	Synchro flange, range (T20613)	Synchronflansch	Bride de synchro	Flangia sincronizzazione	Brida de sin.	2
2300-0917-0080-0060	1	8874923 (T20607)	Synchro flange (T20613)	Synchronflansch	Bride de synchro	Flangia sincronizzazione	Brida de sin.	2
2300-0917-0080-0070	9	8870352 (T20607)	Plunger, synchro	Führungstift	Plongeur	Pistone	Vástago	18
2300-0917-0080-0080	9	X8870355 (T20607)	Roller, synchro	Verriegelungsröle	Rouleau	Rullo	Rodillo	18
2300-0917-0080-0090	9	8870444 (T20607)	Spring, compression	Feder	Ressort	Molla	Muelle	18
2300-0917-0080-0100	1	X8870844 (T20608)	Bearing, synchro hub	Lager	Roulement, moyeu synchro	Rullo	Rodillo	2
2300-0917-0090	1	X8870344	Circlip	Sicherungsring	Circlips	Anello di sicurezza	Anillo elastico	1
2300-0917-0100	1	X8870342	Circlip	Sicherungsring	Circlips	Anello di sicurezza	Anillo elastico	1

**Range Synchroniser Assembly, Synchron-schalt, Synchro-selection de Gamme,
Synchronizzatore-selattore, Sincronizador-selectora gama**

2300-0917-0080-0030
2300-0917-0090
2300-0917-0080-0040
2300-0917-0080-0100

2300-0917-0080-0010
2300-0917-0080-0040

2300-0917-0080-0020
2300-0917-0120
2300-0917-0110
2300-0911
2300-0915
2300-0913

2300-0917-0080-0030
2300-0917-0100
2300-0917-0080-0060

2300-0917-0080-0080
2300-0917-0080-0070
2300-0917-0080-0090

2300-0909
2300-0907
2300-0903
2300-0917-0080-0050
2300-0905
2300-0902

2300 0901 0010

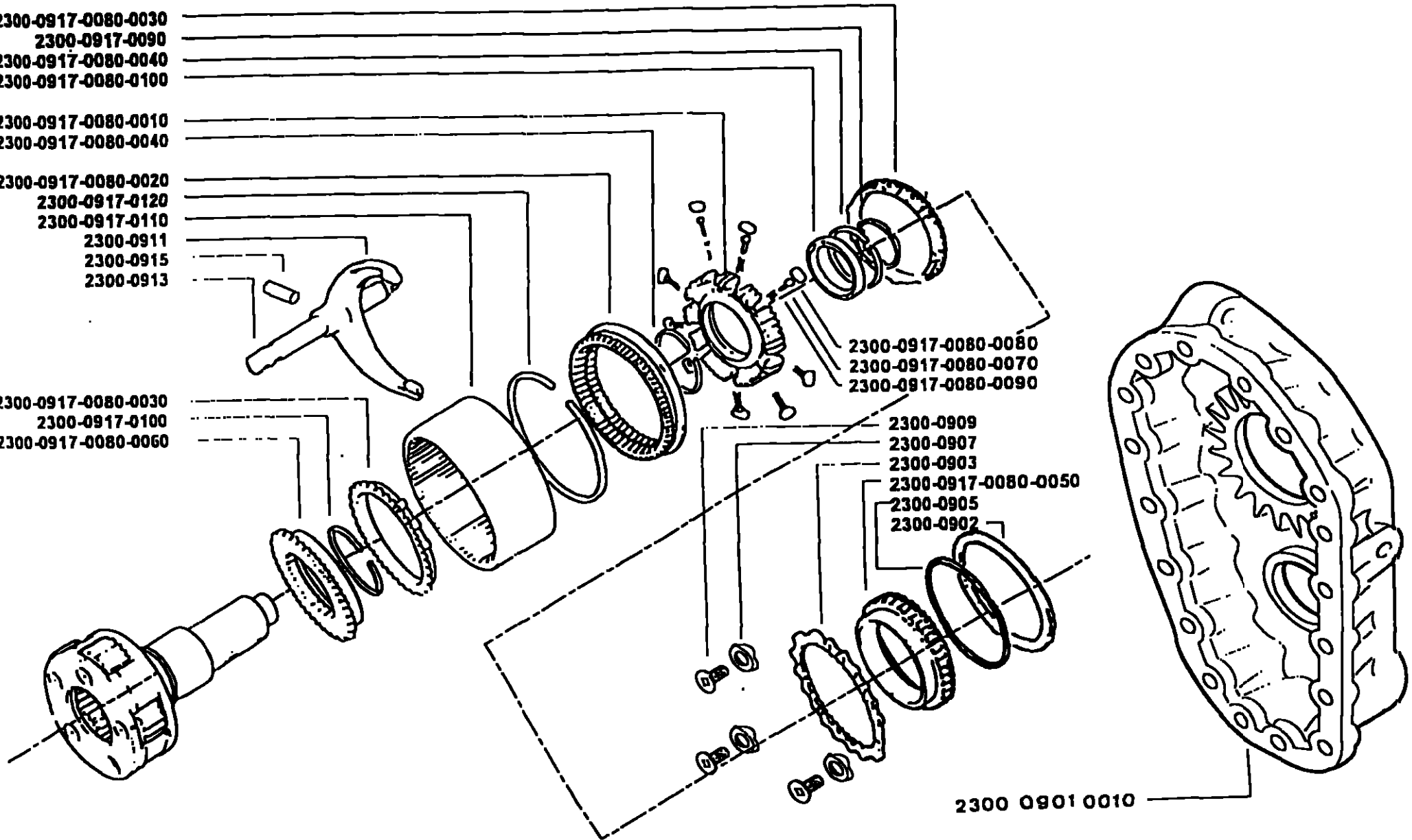

Sequence No	Qty	Part No	English	Deutsch	Francals	Italiano	Espaniol	Stock Qty
2300-0917-0110	1	8872880	Gear, annulus	Zahnrad, innenverzahnt	Pignon, couronne	Anello, ingranaggio	Engr. dientes interiores	1
2300-0917-0120	1	X8875296	Circlip	Sicherungsring	Circlips	Anello di sicurezza	Anillo elastico	1

Filter regulator assy, Filter/Regler Einheit, Filtre/Regulateur, Complessivo Filtro/Regolatore, Conjunto Filtro/Regulator

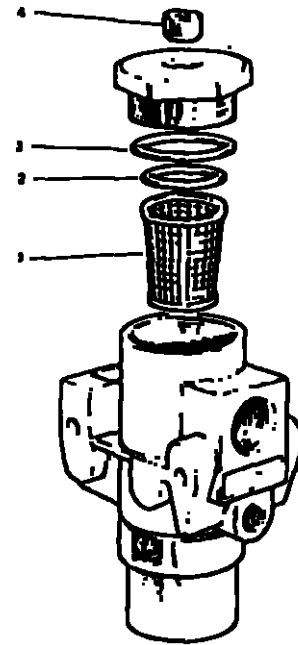
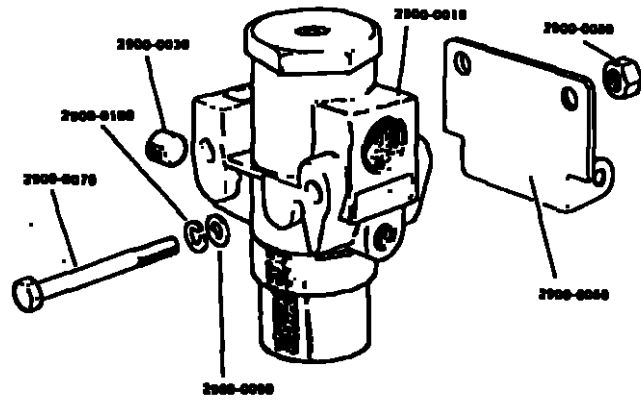

Filter regulator assy, Filter/Regler Einheit, Filtre/Reglateur, Complessivo Filtro/Regolatore, Conjunto Filtro/Regulator

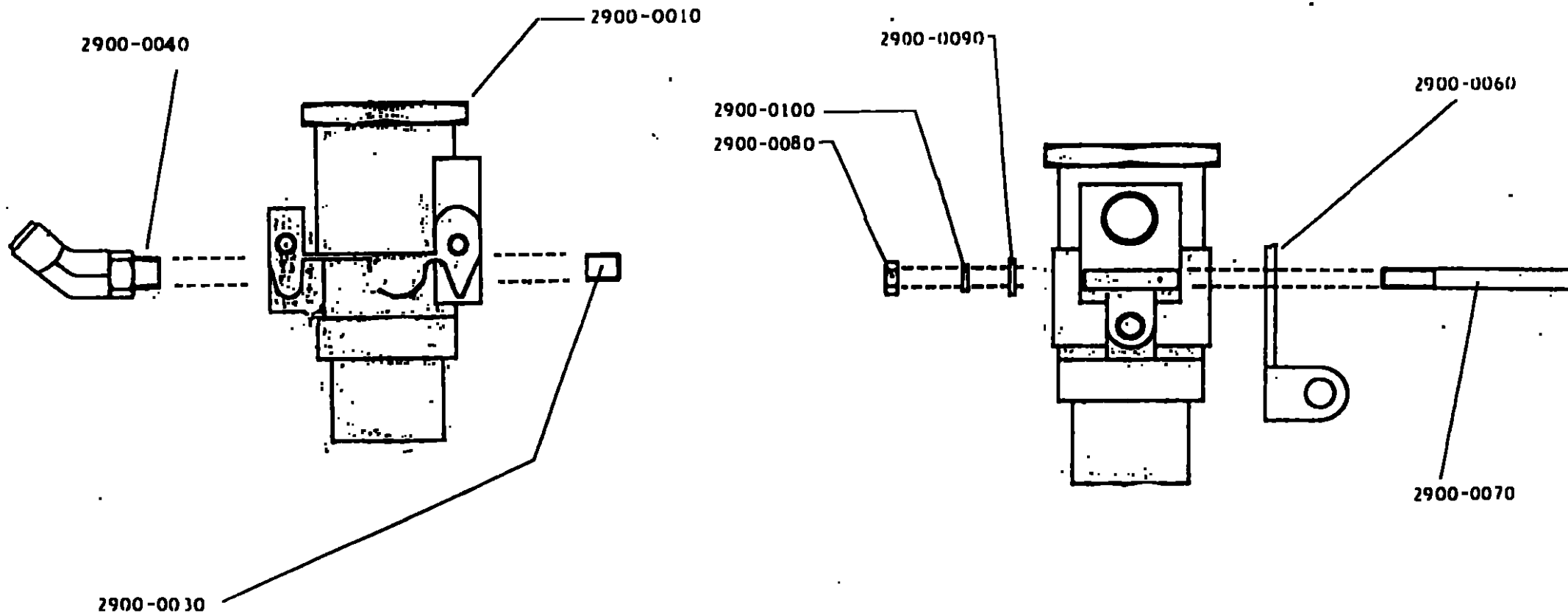

Sequence No	Qty	Part No	English	Deutsch	Francais	Italiano	Espaniol	Stock Qty
2900	Ref	U8877773	Range control assy	Schaltstange	Commande-selecteur	Commando-seletrice	Control-de gama	
2900-0010	1	2005128	Filter regulator assy	Filter/Regler Einheit	Filtre/regulateur	Filtro/regolatore	Filtro/regulator	2
2900-0030	1	X2013517	Pipe plug	Verschlusschraube	Bouchon filete	Tappo filettato	Tapon	0
2900-0040	0		Straight adaptor	Verschraubung	Tube adaptateur droit	Tube connettore diritto	Tube adaptor recto	0
	OR							
2900-0040	1	X8875581	Elbow adaptor 45	Winkelverschraubung	Adapteur 90	Connettore 90	Adaptador 90	-
2900-0050	0		Straight adaptor	Winkelverschraubung	Adapteur 90°	Connettore 90°	Adaptador 90°	0
2900-0080	1	8877649	Bracket	Halter	Support	Supporto	Soporte	0
2900-0070	2	MX-8-0603	Bolt M6 x 55	Schraube M6 x 55	Boulon M6 x 55	Bullone M6 x 55	Perno M6 x 55	0
2900-0080	2	MX-9-0601	Nut M6	Mutter M6	Ecrou M6	Dado M6	Tuerca M6	0
2900-0090	2	MX-10-0601	Washer M6	Scheibe M6	Rondelle M6	Rondella M6	Arandela M6	0
2900-0100	2	MX-3-0602	Spring washer M6	Federring M6	Rondelle grower M6	Rosetta elastica M6	Arandela elastica M6	0

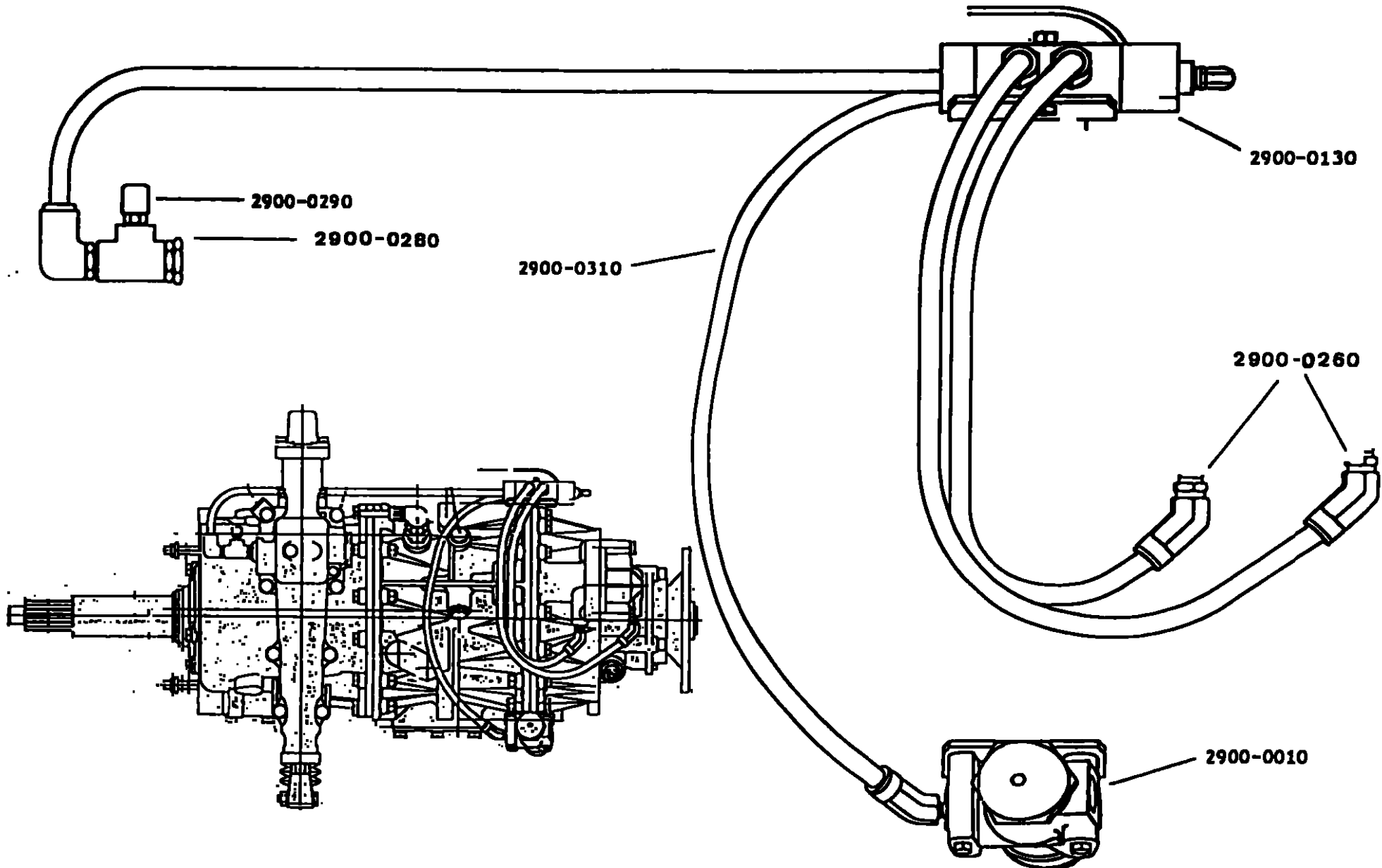

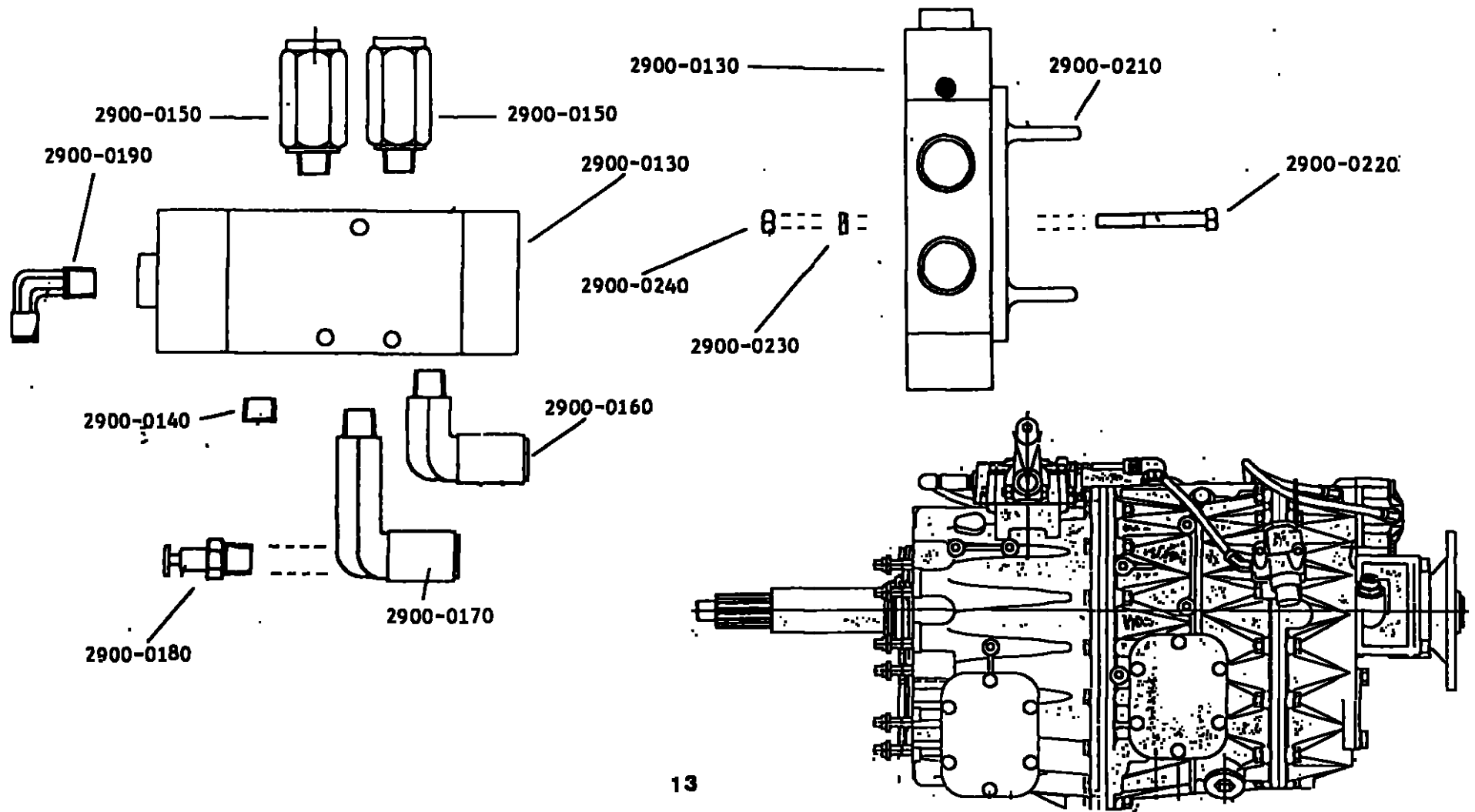

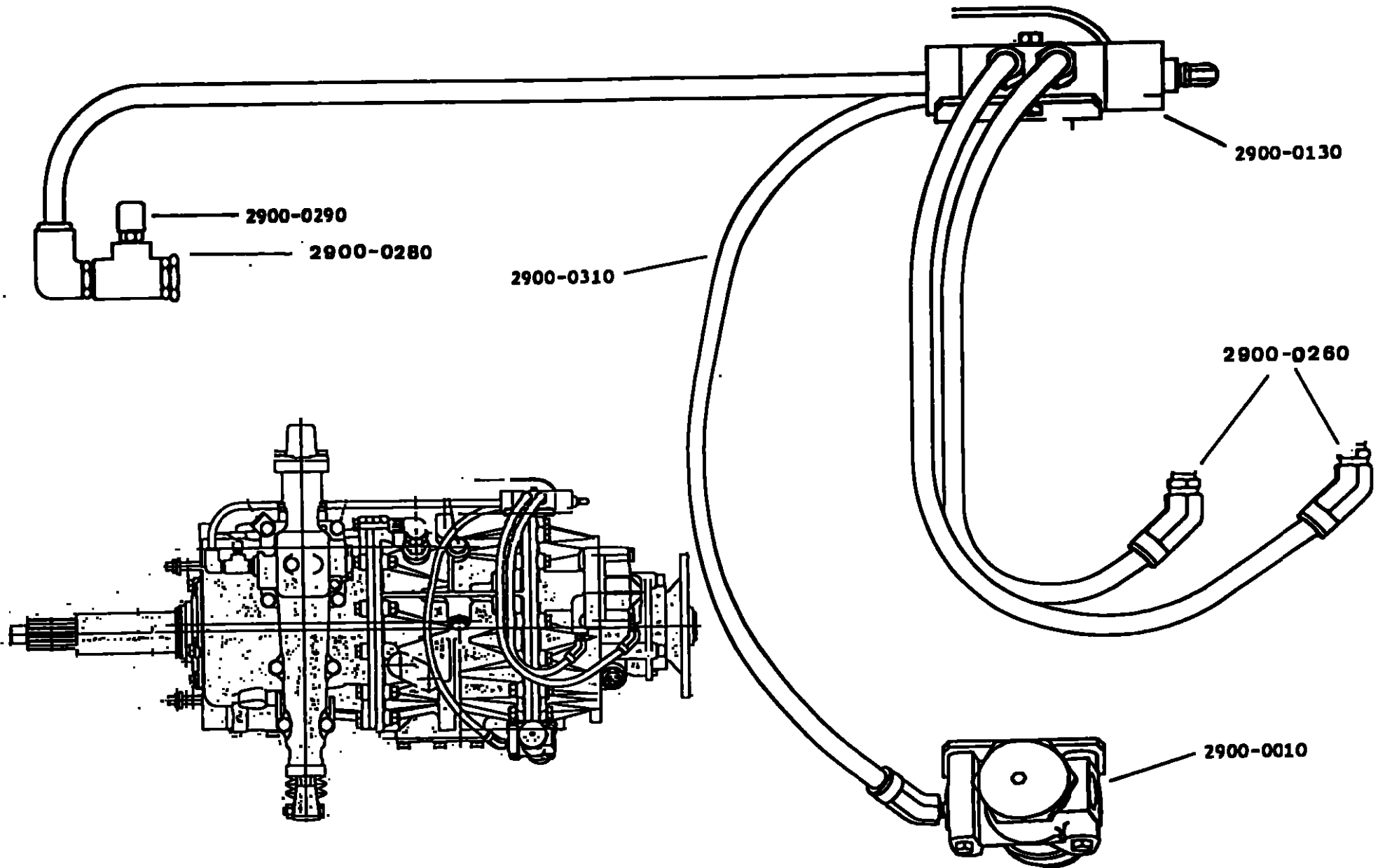

Sequence No	Qty	Part No	English	Deutsch	Francais	Italiano	-	-
2900-0130	1	X8877690	Slava valve	Ventil-	Valve-	Valvola-	Valvula-	1
2900-0140	1	X2013517	Pipe plug	Verschlusschraube	Bouchon filete	Tappo filettato	Tapon	-
2900-0150	2	X8875586	Straight adaptor	Adaptor-	Adaptateur-	Adattore-	Adaptador-	-
2900-0160	1	X8875580	Elbow adaptor-fixed	Winkelverschraubung	Adaptateur 90	Connettore 90	Adaptador 90	-
	OR							
2900-0180	0		Straight adaptor	Adaptor-	Adaptateur-	Adattore	Adaptador-	-
2900-0165	0		Tee 1/8	T-stuck	Element en T	Pezzo a T	Pieza en T	-
2900-0170	1	X8875583	Tee adaptor-ext.				Adaptador 90	-
2900-0180	0		Elbow adaptor-fixed	Winkelverschraubung	Adaptateur 90	Connettore 90	Adaptador 90	-
	OR							
2900-0180	1	X8875584	Straight adaptor	Adaptor-	Adaptateur-	Adattore-	Adaptador-	-
	OR							
2900-0180	0		Connector assy	Verschraubungen	Raccords	Raccordi	Racores	-
2900-0190	1	X8875587	Straight adaptor					
	OR							
2900-0190	0		Elbow assy	Winkelverschraubung	Adaptateur 90	Connettore 90	Adaptador 90	-
2900-0210	1	8877649	Mounting bracket	Halter	Support	Supporto	Soporte	-
2900-0220	2	MX-8-0405	Bolt M4 x 40	Schraube	Boulon	Bullone	Perno	-
2900-0230	2	MX-3-0401	Spring washer M4	Federring	Rondelle grower	Rosetta elastica	Arandela elastica	-
2900-0240	2	MX-9-0402	Nut M4	Mutter	Ecrou	Dado	Tuerca	-
2900-0260	2	X8875588	Elbow-swivel 45	Winkelverschraubung =	Coudes-	Raccordo a gomita	Tubo acodado	-
	OR							
2900-0260	0		Straight adaptor	Adaptor-	Adaptateur-	Adattore-	Adaptador-	-
2900-0280	1	X8877766	Poppet valve	Ventil	Valve(H)	Valvola(H)	Valvula(H)	2
2900-0290	1	7935	Air vent	Entlufter	Reniflard	Sfratatoi	Respiro	-
2900-0300	1	X8875588	Straight adapter					

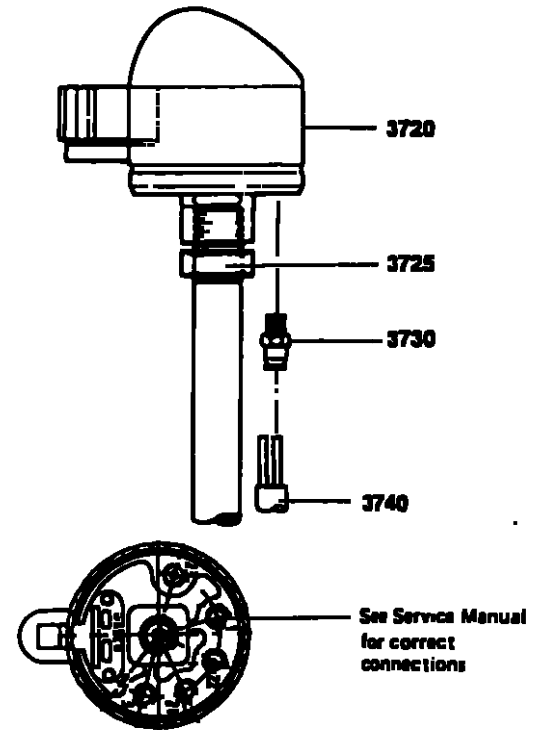
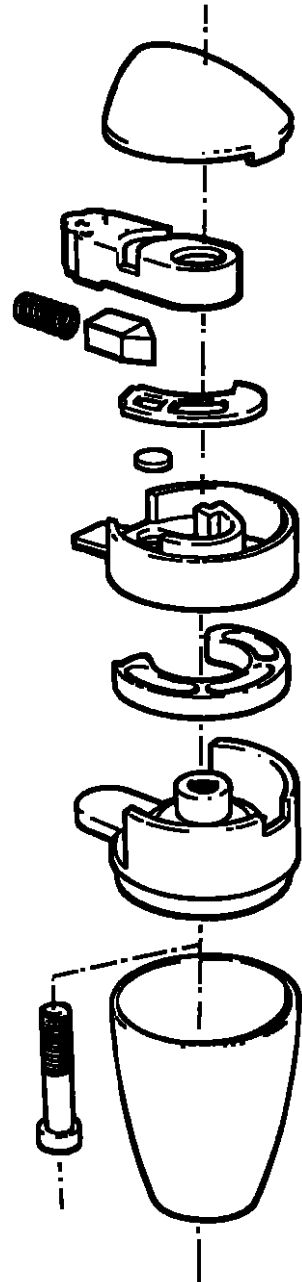

2900-0310	-	X8873690	Nylon tubing	Nylonschlauch	Tube en nylon	Tube nailon	Tube nylon	-
2950-0010	0		Solenoid valve-u/shift clutch brake	Magnetventil-brems	Solenoide de la valve-frein	Valvola elettropn.-freno	Valvula de solenoid-freno	1
2950-0020	0		Bolt M6 x 45	Schraube	Boulon	Bullone	Perno	-
2950-0030	0		Washer M6	Scheibe	Rondelle	Rosetta	Arandela	-
2950-0040	0		Nut M6	Mutter	Ecrou	Dado	Tuerca	-
2950-0050	0		Straight adaptor	Adapter-	Adaptateur-	Adattore-	Adaptador-	-
2950-0060	0		Elbow adaptor	Winkelverschraubung	Coude	Raccordo a gomita	Tubo acodado	-
2950-0070	0		Pressure tubing, Nylon	Nylonschlauch	Tube en nylon	Tube nailon	Tube nylon	-
2950-0080	0		Cable switch assy	Druckschalter-kabel	Contacteur-cable	Interruttore-cavo	Interruptor-cable	1
3720	1	F96202	Control valve, 2-way	Schaltventil	Valve de selection	Valvola selettice	Valvula selectora	2
3725	1	X-9-802	Locknut	Mutter	Ecrou	Dado	Tuerca	0
3730	0		Connector assy-sol.switch	Verschraubungen-druckschalter	Raccord-contacteur	Raccordi-interruttore	Racores-interruptor	-
	OR							
3730	2	X8875564	Straight adaptor	Verschraubung gerade	Raccord	Raccordo	Boquilla	2
3740	1	F92955	Tube and sheath assy	Schlauch komplett	Flexibles et gaine	Tubo flessibile a guaina	Tuberias y funda	1
3745	0		Tubing-air	Schlauch komplett	Flexibles et gaine	Tubo flessibile a guaina	Tuberias y funda	1

(8209)

9 SPEED SERVICE KIT T20604 CRAW/REV SYNCHRO KIT (NON-SYNCHRONISED)

PART NUMBER	QUANTITY	PART DESCRIPTION - ENGLISH
8876166	1	SYNCHRO FLANGE
8870415	1	SYNCHRO FLANGE REV
8875804	1	FIXED HUB
8875376	1	SLIDING SLEEVE
X8873994	2	CIRCLIP
8870352	3	PLUNGER
X8870356	3	ROLLER
8870444	3	SPRING
X14185	1	LOCTITE 648-50ML

9 SPEED SERVICE KIT T20605 1ST/2ND SYNCHRO KIT

PART NUMBER	QUANTITY	PART DESCRIPTION - ENGLISH
8871639	2	SYNCHRO FLANGE
8875571	1	FIXED HUB 1/2
8875377	1	SLIDING SLEEVE 1/2
8875135	2	SYNCHRO RING
8870352	3	PLUNGER
X8870356	3	ROLLER
8870444	3	SPRING
X14185	1	LOCTITE 648-50ML

9 SPEED SERVICE KIT T20606 3RD/4TH SYNCHRO KIT

PART NUMBER	QUANTITY	PART DESCRIPTION - ENGLISH
8871639	2	SYNCHRO FLANGE
8875554	1	FIXED HUB 3/4
8875377	1	SLIDING SLEEVE 3/4
8875135	2	SYNCHRO RING
8870352	3	PLUNGER
X8870356	3	ROLLER
8870444	3	SPRING
X14185	1	LOCTITE 648-50ML

9 SPEED SERVICE KIT T20607 RANGE SYNCHRO KIT

PART NUMBER	QUANTITY	PART DESCRIPTION - ENGLISH
8874037	1	SYNCHRO FLANGE
8874923	1	SYNCHRO FLANGE
8875881	1	FIXED HUB
8873041	1	SLIDING SLEEVE
8875183	2	SYNCHRO RING
X8870341	2	CIRCLIP
8870352	9	PLUNGER
X8870355	9	ROLLER
8870444	9	SPRING
X14185	1	LOCTITE 648-50ML

9 SPEED SERVICE KIT T20608 BEARING KIT

PART NUMBER	QUANTITY	PART DESCRIPTION - ENGLISH
X8872593	1	BEARING - INPUT SHAFT
X8870305	1	NEEDLE BEARING
X8875276	1	NEEDLE BEARING
X8872233	3	NEEDLE BEARING
X8870178	1	NEEDLE BEARING
X8877164	1	BEARING - REAR MAINSHAFT
X8872721	1	BEARING - OUTPUT
X8875587	2	BEARING - LAYSHAFT
X8872478	2	BEARING - REVERSE IDLER
X8870844	1	BALL BEARING
T20275	5	NEEDLE BEARING PLANET KIT

9 SPEED SERVICE KIT T20609 GASKET/SEAL KIT

PART NUMBER	QUANTITY	PART DESCRIPTION - ENGLISH
X8872722	1	OIL SEAL - REAR COVER
X8870760	1	OIL SEAL - FRONT COVER
X8871394	1	OIL SEAL - LRC
F96083	1	COPPER WASHER
X8874864	1	LOCTITE 518 65ML
8870590	2	GASKET - DETENT COVER
1684	2	GASKET 6 HOLE
8873734	1	GASKET - LRC

9 SPEED SERVICE KIT T20611 1ST/2ND & 3RD/4TH SYNCHRO FLANGE & RING KIT

PART NUMBER	QUANTITY	PART DESCRIPTION - ENGLISH
8871639	1	SYNCHRO FLANGE
8875135	1	SYNCHRO RING
X14185	1	LOCTITE 648-50ML

9 SPEED SERVICE KIT T20613 RANGE SYNCHRO FLANGE & RING KIT

PART NUMBER	QUANTITY	PART DESCRIPTION - ENGLISH
8874037	1	SYNCHRO FLANGE
8874923	1	SYNCHRO FLANGE
8875183	2	SYNCHRO RING
X14185	1	LOCTITE 648-50ML

9 SPEED SERVICE KIT T20344 COUNTERSHAFT BEARING SHIM KIT

PART NUMBER	QUANTITY	PART DESCRIPTION - ENGLISH
8875879	1	SPACER
F88891	1	SHIM (0.051mm)
F88892	1	SHIM (0.127mm)
F88893	1	SHIM (0.254mm)
F88894	1	SHIM (0.508mm)

9 SPEED SERVICE KIT T20183 O-RING KIT - RANGE

PART NUMBER	QUANTITY	PART DESCRIPTION - ENGLISH
14344	1	O-RING - RANGE
14345	1	O-RING - RANGE
MX-9-1602	1	NUT - RANGE
X8873008	1	O-RING - RANGE
X8876391	1	O-RING - FRONT COVER
X8876392	1	O-RING - FRONT COVER
X8871258	1	O-RING - REAR CASE
X8875292	1	O-RING - REAR CASE

9 SPEED SERVICE KIT T20185 GRADED CIRCLIP KIT

PART NUMBER	QUANTITY	PART DESCRIPTION - ENGLISH
X8870534	1	GRADED CIRCLIP (2.10mm)
X8870378	1	GRADED CIRCLIP (2.10mm)
X8870379	1	GRADED CIRCLIP (2.05mm)
X8870536	1	GRADED CIRCLIP (2.00mm)
X8870380	1	GRADED CIRCLIP (2.00mm)
X8870370	2	GRADED CIRCLIP (2.12mm)
X8871536	1	GRADED CIRCLIP (1.97mm)
X8870371	2	GRADED CIRCLIP (2.07mm)
X8871537	1	GRADED CIRCLIP (1.92mm)
X8870372	2	GRADED CIRCLIP (2.02mm)
X8871538	1	GRADED CIRCLIP (1.87mm)
X8871539	1	GRADED CIRCLIP (1.82mm)
X8871540	1	GRADED CIRCLIP (1.77mm)

9 SPEED SERVICE KIT T20275 NEEDLE ROLLING BEARING KIT

PART NUMBER	QUANTITY	PART DESCRIPTION - ENGLISH
U8875235	1	NEEDLE ROLLER BEARING ASSY
8873184	2	WASHER
MX-11-0601	1	SCREW

9 SPEED SERVICE KIT U8876148 BEARING KIT

PART NUMBER	QUANTITY	PART DESCRIPTION - ENGLISH
X8872593	1	BEARING - INPUT SHAFT
8872484	1	GRADED SPACER (3.70MM)
8872485	1	GRADED SPACER (3.75MM)
8872486	1	GRADED SPACER (3.80MM)
8872487	1	GRADED SPACER (3.85MM)
8872488	1	GRADED SPACER (3.90MM)
8872489	1	GRADED SPACER (3.95MM)
X8872472	1	CIRCLIP