



Powering Business Worldwide

Illustrated Parts List

Y05243

November 2015

Contents

How To Use The Illustrated Parts List	3
FRONT BEARING COVER ASSY.	4
FRONT CASE ASSY.....	5
INPUT SHAFT ASSY.....	7
LAYSHAFT ASSY.	8
LRC ASSEMBLY	10
MAINSHAFT ASSY.....	12
REAR CASE ASSY.	15
REVERSE IDLER SHAFT.....	17
SELECTOR ASSY.	18
SPEEDO HOUSING.....	19
SYNCHRO PACK D.C.1ST/2ND.....	21

How To Use The Illustrated Parts List

The information contained in this document is subject to frequent updates. Therefore, for the latest information available, please visit the interactive Electronic Parts Catalog at <http://www.eaton.com/EatonCom/TruckEurope/TruckEurope/index.htm>

Model Designation and Nomenclature

- For information regarding Model Designation and Nomenclature, visit <http://www.eaton.com/EatonCom/TruckEurope/TruckEurope/index.htm>

Kits and Assemblies (K/A's)

- Kits or Assemblies contain groups of individual or assembled parts specially developed for optimal replacement during repair.
- Kits and Assemblies are shown with applicable parts groupings in the parts listings.

Identifying Kits and Assemblies

A- Part numbers beginning with the letter 'A' are pre-assembled Production Assemblies

K- Part numbers beginning with the letter 'K' are kits that are not assembled

T - Part numbers beginning with the letter 'T' are kits that are not assembled

S- Part numbers beginning with the letter 'S' are pre-assembled Service Assemblies

- Note: Some Production Assemblies do not begin with a letter prefix (Midrange only).

Illustrations

- Illustrations show parts in assembly groups.
- Item numbers on illustrations correspond with parts listings adjacent to the illustration.(on the same or adjacent page)
- Notes are included on illustrations where additional information is needed.

Parts Listing

Parts listings are defined by parts groupings and are broken down by service assemblies. Parts listings identify a part for servicing with the following categories

- **ITEM** - Number corresponds to number on illustration for part identification.
- **CURRENT PART** - part number of the part available for service.
- **DESCRIPTION** - part name or description.
- **REPLACED PART** - number of replaced part.
- **QTY** - Quantity required for assembly.
- **NOTES** - unique characteristics or requirements.
- **KITS / ASSYS WHERE NEEDED** - kits or assemblies that contain the part.

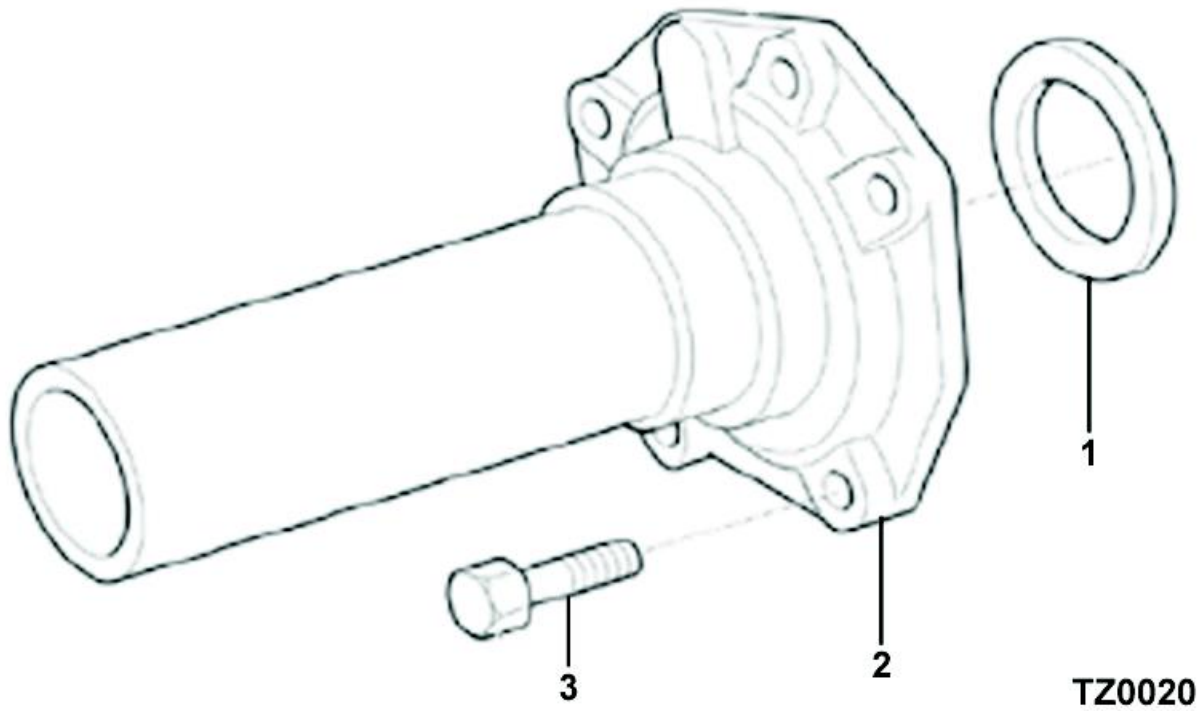

FRONT BEARING COVER ASSY.

Item	Current Part	Description	Replaced Part	Qty.	Notes	Kits/Assys Where Needed
0	U8872546	FRONT BEARING COVER ASSY.		1		
1	X8870760	OIL SEAL		1		
2	8872547	FRONT BEARING COVER		1		
3	GMX-8-1089	SCREW		5	M10X25 HEX FLG HD	

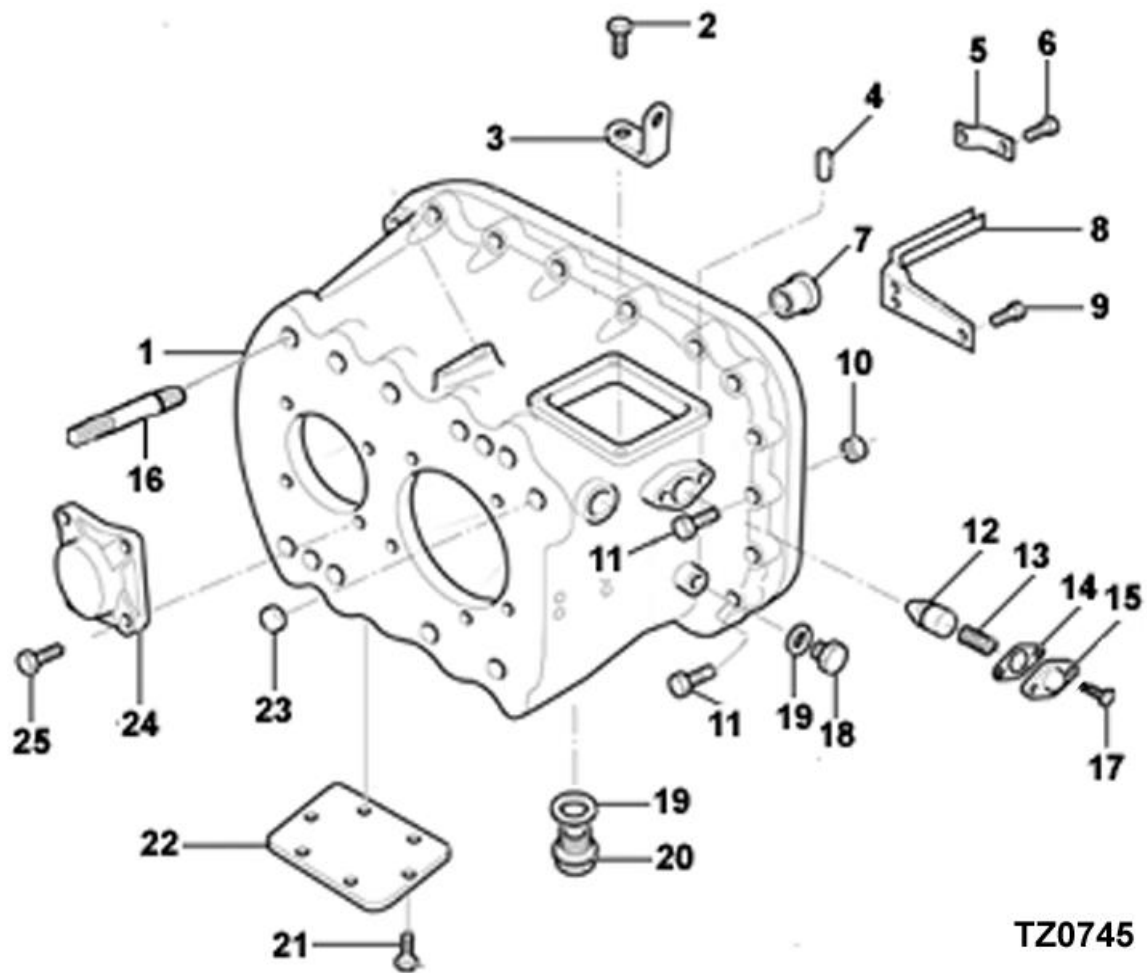

TZ0745

FRONT CASE ASSY

Item	Current Part	Description	Replaced Part	Qty.	Notes	Kits/Assys Where Needed
0	U8882257	FRONT CASE ASSY.		1		
1	U8881866	FRONT CASE		1		
2	GMX-8-1091	SCREW		4	M10X30 HEX FLG HD	
4	X8870542	DOWEL		2	8,0 DIA X 16	
5	8877430	OIL TROUGH		1		
6	X8872604	SCREW		2		
7	8883756	BUSH	8882415	1	FOR MAIN SELECTOR SHAFT	
8	8877431	OIL TROUGH		1		
9	8874473	SCREW		3		
10	GMX-9-1005	NUT		15	M10X1.5	

Item	Current Part	Description	Replaced Part	Qty.	Notes	Kits/Assys Where Needed
11	GMX-8-10110	BOLT		1	DETENT COVER SIDE	
11	GMX-8-1079	BOLT		3	M10X40	
11	GMX-8-1080	BOLT		13	M10X58	
11	GMX-8-1094	BOLT		1	M10X55 HEX FLG HD, MAGNETIC PLUG SIDE	
12	8873654	PLUNGER-NEUTRAL		1		
13	8876679	SPRING COMPRESSION		1		
14	8870590	GASKET		1		
15	GX8870259	DETENT COVER		1		
16	GX8879212	LIFTING EYE		1	15 MM	
16	GX8879212	LIFTING EYE		1	15 MM	
17	GMX-8-0819	SCREW	GMX-8-0801	2	M8 X 16	
18	GX8874942	OIL FILLER PLUG		1		
19	X8880519	WASHER-FILL/DRAIN FL		2		
20	GX8874941	MAGNETIC PLUG		1	M24	
21	GMX-8-1088	SCREW		6	M12X25 HEX FLG HD	
22	8881616	PTO PROVISION COVER		1		
23	GX8870278	CUP PLUG		1		
24	GX8880554	BEARING COVER LAYSHAFT		1		
25	GMX-8-1240	SCREW		4	M12X25 HEX FLG HD	
26	GX8873931	STUD		8	M12X45 LONG	
26	GX8874699	STUD	GX8881103	2	M12X65 LONG	

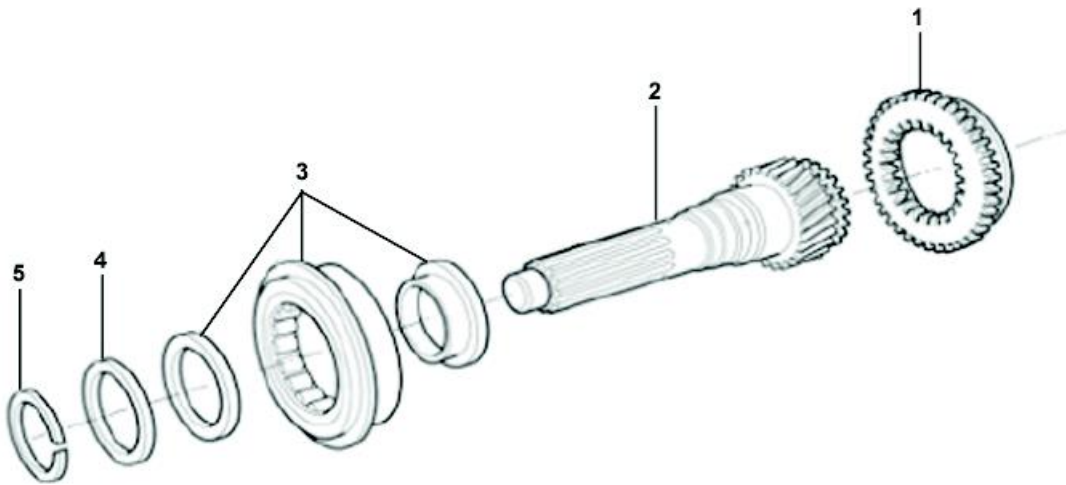

TZ0019

INPUT SHAFT ASSY.

Item	Current Part	Description	Replaced Part	Qty.	Notes	Kits/Assys Where Needed
0	U8880782	INPUT SHAFT ASSY.		1		
1	8877318	SYNCHRO FLANGE		1		
2	8880783	INPUT SHAFT		1		
3	X8872593	INPUT SHAFT BEARING		1		
4	8877692	SPACER - GRADED 3.10		1	PACK: U8877691	
4	8877693	SPACER - GRADED 3.15		1	PACK: U8877691	
4	8877694	SPACER - GRADED 3.20		1	PACK: U8877691	
4	8877695	SPACER - GRADED 3.25		1	PACK: U8877691	
4	8877696	SPACER - GRADED 3.30		1	PACK: U8877691	
4	8877697	SPACER - GRADED 3.35		1	PACK: U8877691	
4	8877698	SPACER - GRADED 3.40		1	PACK: U8877691	
4	8877699	SPACER - GRADED 3.45		1	PACK: U8877691	
4	8877700	SPACER - GRADED 3.50		1	PACK: U8877691	
4	U8877691	SPACER - GRADED PACK		1		
5	X8877706	CIRCLIP		1		

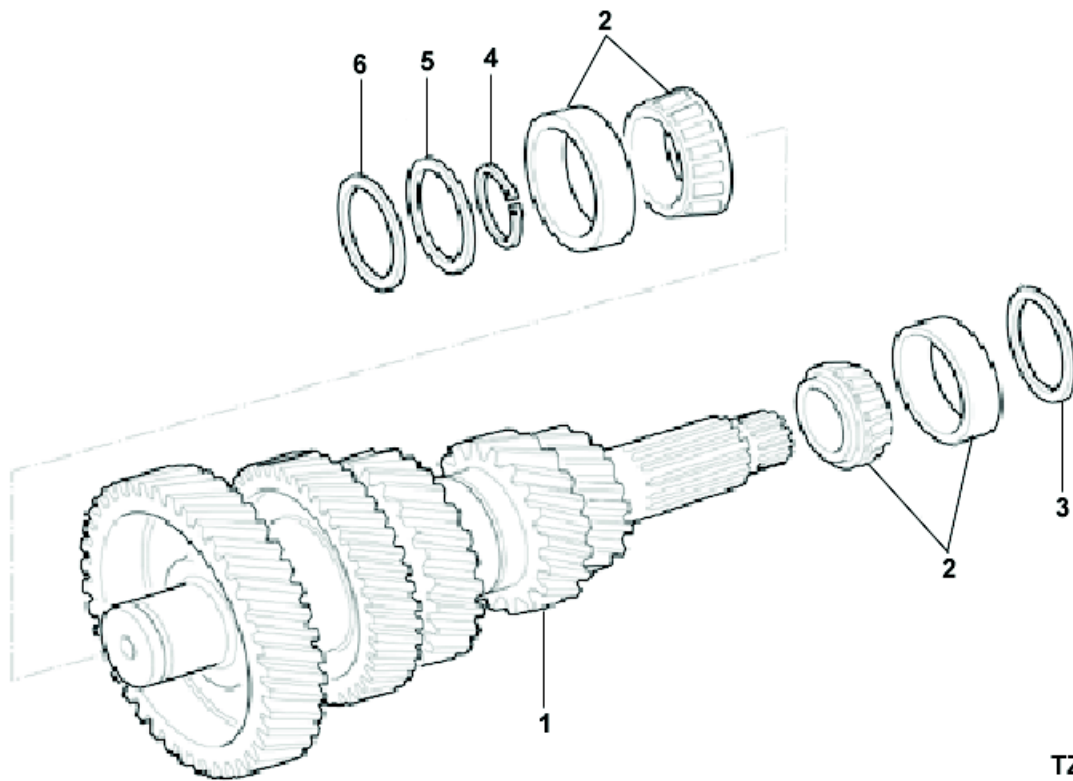

TZ0023

LAYSHAFT ASSY.

Item	Current Part	Description	Replaced Part	Qty.	Notes	Kits/Assys Where Needed
1	U8882756	LAYSHAFT ASSY.		1		
2	X8875587	BEARING ASSEMBLY		2		
3	8872210	DISTANCE PIECE		1		
4	U8877534	CIRCLIP GRADED PACK		1		
4	X8870370	GR.C/CLIP 40 DIA. X 2.12 MM		1		
4	X8870371	GR.C/CLIP 40 DIA. X 2.07 MM		1		
4	X8870372	GR.C/CLIP 40 DIA X 2.02 MM		1		
4	X8871536	GR.C/CLIP 40 DIA. X 1.97 MM		1		
4	X8871537	GR.C/CLIP 40 DIA. X 1.92 MM		1		
4	X8871538	GR.C/CLIP 40 DIA. X 1.87 MM		1		
4	X8871539	GR.C/CLIP 40 DIA. X 1.82 MM		1		

Item	Current Part	Description	Replaced Part	Qty.	Notes	Kits/Assys Where Needed
4	X8871540	GR.C/CLIP 40 DIA. X 1.77 MM		1		
5	F88891	SHIM		1	S=0,051	
5	F88892	SHIM		1	S=0,127	
5	F88893	SHIM		1	S=0,254	
5	F88894	SHIM		1	S=0,508	
5	U8877535	SHIM PACK		1		
5	X8882272	SHIM		1	S=1,200	
6	8875879	SPACER		1		

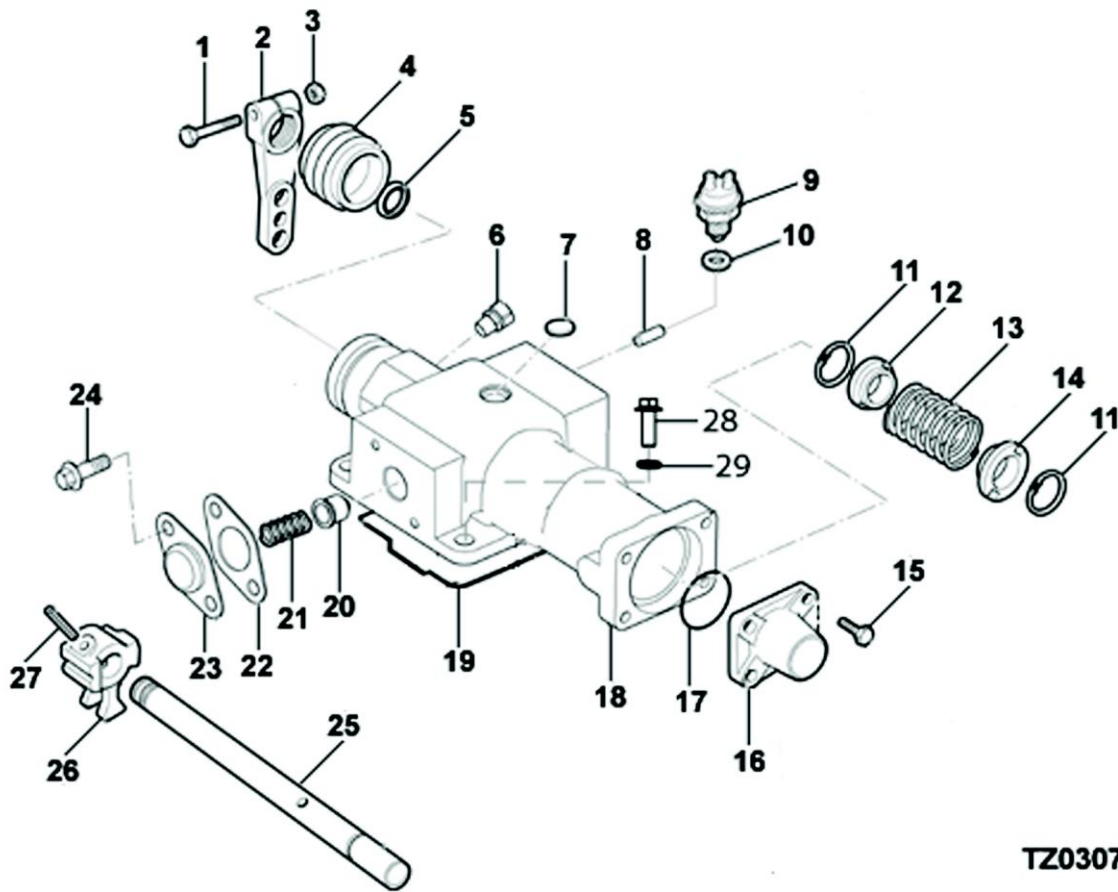

TZ0307

LRC ASSEMBLY

Item	Current Part	Description	Replaced Part	Qty.	Notes	Kits/Assys Where Needed
0	U8881056	LRC ASSEMBLY		1		
1	GMX-8-1007	BOLT		1	M10X50	
2	GX8876696	GEAR LEVER DIRECT CONTROL		1		
3	GMX-9-1005	NUT		1	M10X1.5	
4	X8875259	BOOT		1		
5	X8881481	OIL SEAL		1		
6	X2014210	BREATHER		1		
7	GX8871486	EXPANSION PLUG		1		
8	8871375	SWITCH ACTIVATOR PIN		1		
9	8880315	NEUTRAL SWITCH		1		
10	5568510	O-RING		1		

Item	Current Part	Description	Replaced Part	Qty.	Notes	Kits/Assys Where Needed
11	X8874450	CIRCLIP		2	25.DIA	
12	8876566	SPRING RETAINER- BOOSTER		1		
13	8873736	BIAS SPRING		1		
14	8876567	SPRING RETAINER-BIAS		1		
15	GMX-8- 0847	SCREW		4		
16	8880477	END CAP		1		
17	X8880639	O-RING		1		
18	U8880695	LRC SUB ASSY.		1		
19	8880638	SEAL		1		
20	8875415	PLUNGER - DETENT		1		
21	8874897	SPRING COMPRESSION		1		
22	8870590	GASKET		1		
23	GX8870259	DETENT COVER		1		
24	GMX-8- 0848	SCREW		2		
25	8877154	SHIFT ROD		1		
26	8877658	INNER STRIKING LEVER		1		
27	X8871378	DOWEL		1	10,0 DIA X 44	
28	GMX-8- 1091	SCREW		4	M10X30 HEX FLG HD	
29	GMX-3- 1001	SPRING WASHER		4	M10	

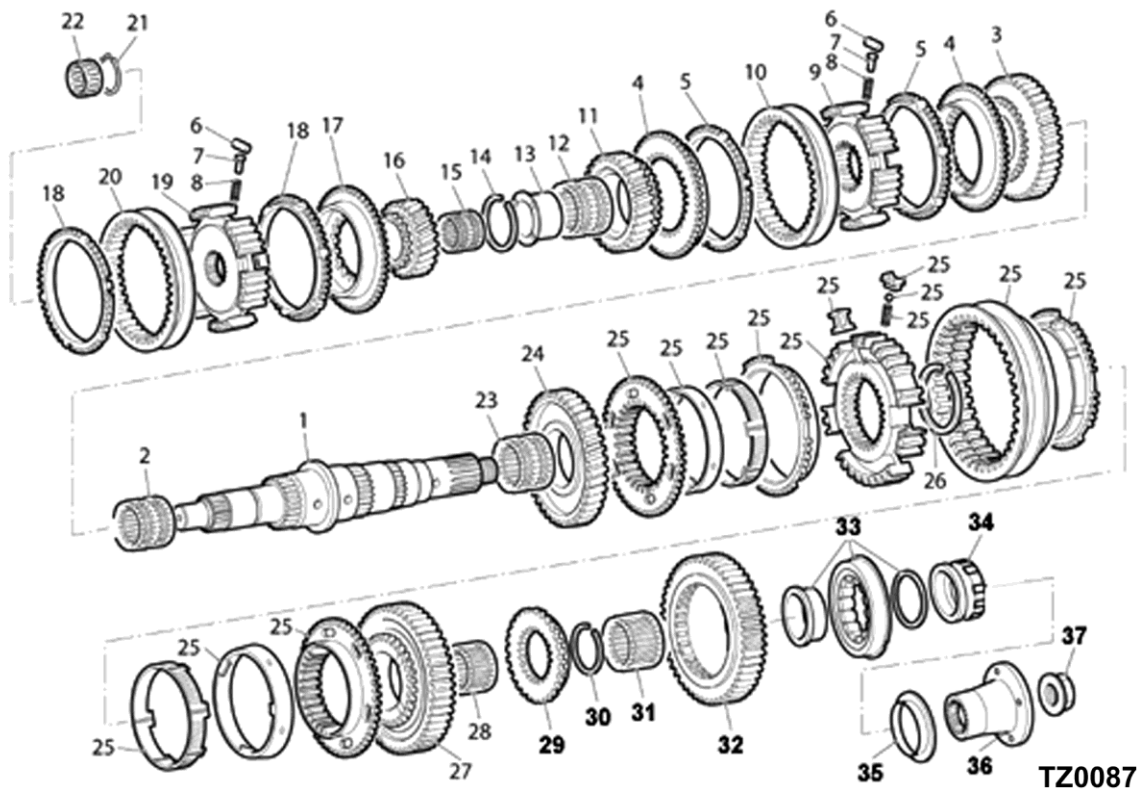

MAINSHAFT ASSY.

Item	Current Part	Description	Replaced Part	Qty.	Notes	Kits/Assys Where Needed
0	U8882783	MAINSHAFT ASSY.		1		
1	8876898	MAINSHAFT		1		
2	X8872236	NEEDLE ROLLER BRG. ASSY.		1		
3	8880491	GEAR MAINSHAFT 3RD		1		
4	8877316	SYNCHRO FLANGE		2		
5	8877313	SYNCHRO RING		2		
6	X8870356	ROLLER		6		
7	8870352	PLUNGER		6		
8	8870444	SPRING COMPRESSION		6		
9	8875128	FIXED HUB 3RD/4TH		1		
10	8875374	SLIDING SLEEVE		1		
11	8876906	GEAR MAINSHAFT 4TH	8880428	1		
12	X8872233	NEEDLE ROLLER BRG. ASSY		1		
13	8882868	SLEEVE MAINSHAFT		1		

Item	Current Part	Description	Replaced Part	Qty.	Notes	Kits/Assys Where Needed
		BEARING				
14	U8882558	GRADED CIRCLIP PACK		1		
14	X8870534	GR.CIRCLIP 46 DIA. X 2.10 MM		1	PACK: U8882558	
14	X8870535	GR.CIRCLIP 46 DIA. X 2.05 MM		1	PACK: U8882558	
14	X8870536	GR.CIRCLIP 46 DIA. X 2.00 MM		1	PACK: U8882558	
14	X8883040	CIRCLIP GRADED 46 DIA X2.15 MM		1	PACK: U8882558	
14	X8883041	CIRCLIP GRADED 46 DIA X 2.20 MM		1	PACK: U8882558	
15	X8870180	NEEDLE BEARING		1		
16	8882731	GEAR MAINSHAFT 5TH		1		
17	8877317	SYNCHRO FLANGE		1		
18	8877314	SYNCHRO RING		2		
19	8875127	FIXED HUB 5TH/6TH		1		
20	8875375	SLIDING SLEEVE		1		
21	U8877531	GRADED CIRCLIP PACK		1		
21	X8870370	GR.C/CLIP 40 DIA. X 2.12 MM		1		
21	X8870371	GR.C/CLIP 40 DIA. X 2.07 MM		1		
21	X8870372	GR.C/CLIP 40 DIA X 2.02 MM		1		
22	X8870305	NEEDLE BRG.ROLLER ASSY		1		
23	X8872236	NEEDLE ROLLER BRG. ASSY.		1		
24	8876904	GEAR MAINSHAFT 2ND	8881310	1		
25	U8882160	SYNCHRO PACK D.C.1ST/2ND		1		
26	U8876620	GRADED CIRCLIP PACK		1		
26	X8876597	CIRCLIP GR.DIA. 65 X 4.15		1	PACK: U8876620	
26	X8876598	CIRCLIP-GR.DIA. 65 X 4.10		1	PACK: U8876620	
26	X8876599	CIRCLIP-GR.DIA. 65 X 4.05		1	PACK: U8876620	
26	X8876600	CIRCLIP-GR.DIA. 65 X 4.00		1	PACK: U8876620	

Item	Current Part	Description	Replaced Part	Qty.	Notes	Kits/Assys Where Needed
26	X8876601	CIRCLIP-GR.DIA. 65 X 3.95		1	PACK: U8876620	
27	8882159	GEAR MAINSHAFT 1ST		1		
28	X8870177	NEEDLE ROLLER BRG. ASSY		1		
29	8876602	HUB FIXED REVERSE		1		
30	U8882193	GRADED CIRCLIP PACK		1		
30	X8870378	CIRCLIP-GR.DIA.60 X 2.10 MM		1		
30	X8870379	CIRCLIP-GR.DIA.60 X 2.05 MM		1		
30	X8870380	CIRCLIP-GR.DIA.60 X 2.00 MM		1		
31	X8870178	NEEDLE ROLLER BRG. ASSY		1		
32	8880487	GEAR MAISHAFT REVERSE		1		
33	X8877197	BRG.M/S OUTPUT INT SPACER		1		
34	8876501	TACHOGRAPH ROTOR		1		
35	8876869	DIRT SHIELD		1		
36	GX8877443	COUPLING FLANGE		1		
37	GX8870564	MAINSHAFT NUT		1	M33	

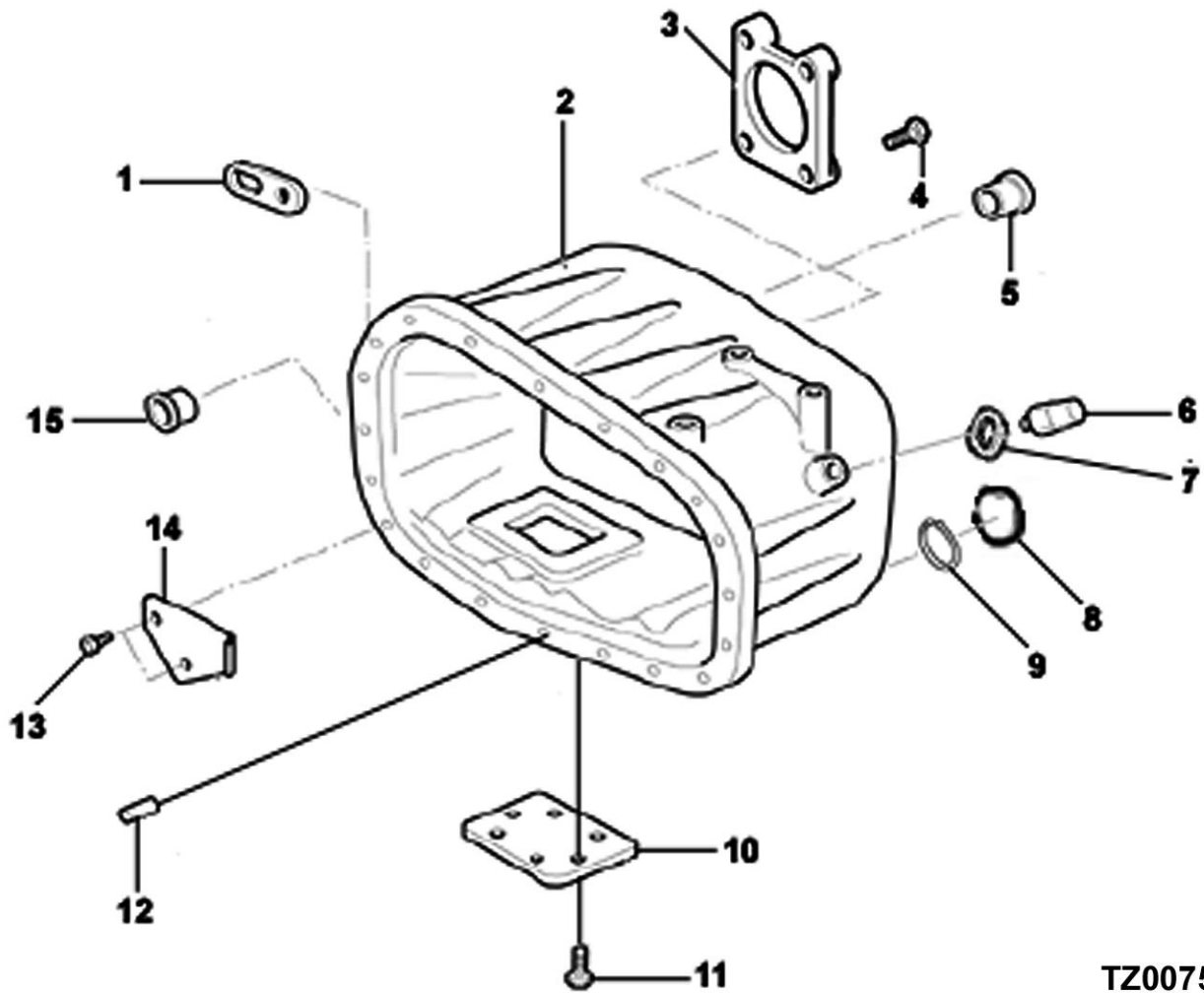

TZ0075

REAR CASE ASSY.

Item	Current Part	Description	Replaced Part	Qty.	Notes	Kits/Assys Where Needed
0	U8880779	REAR CASE ASSY.		1		
1	GX8879211	LIFTING EYE		1		
2	8880946	REAR CASE		1		
3	GX8880554	BEARING COVER LAYSHAFT		1		
4	GMX-8-1239	SCREW		4	M12 X 25 HEX FLG HD	
5	GX8870278	CUP PLUG		1		
6	GX2771532	SWITCH REVERSE / RANGE		1		
7	5568510	O-RING		1		

Item	Current Part	Description	Replaced Part	Qty.	Notes	Kits/Assys Where Needed
8	X8880496	CORE PLUG		1	37.DIA	
9	X8881424	CIRCLIP		1		
10	8881616	PTO PROVISION COVER		1		
11	GMX-8-1088	SCREW		6	M12X25 HEX FLG HD	
12	X8870543	DOWEL		2	16,0 DI X 30,5	
13	8874473	SCREW		2		
14	8874494	PLATE OIL RETENTION		1		
15	8883756	BUSH	8882415	1	FOR MAIN SELECTOR SHAFT	

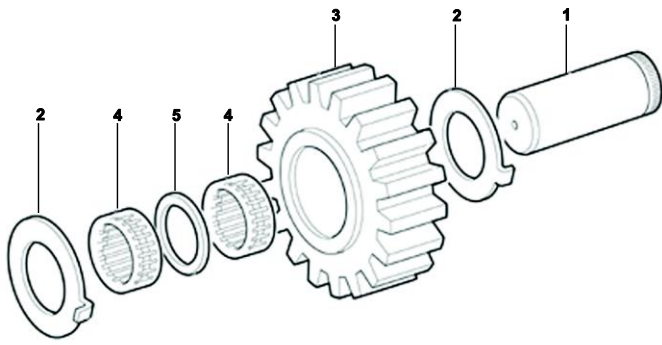

TZ0007

REVERSE IDLER SHAFT

Item	Current Part	Description	Replaced Part	Qty.	Notes	Kits/Assys Where Needed
1	8883246	REVERSE IDLER SHAFT		1		
2	8870343	THRUST WASHER		2		
3	8872173	GEAR IDLER REVERSE		1		
4	X8872478	NEEDLE ROLLER BRG		2		
5	8872479	SPACER		1		

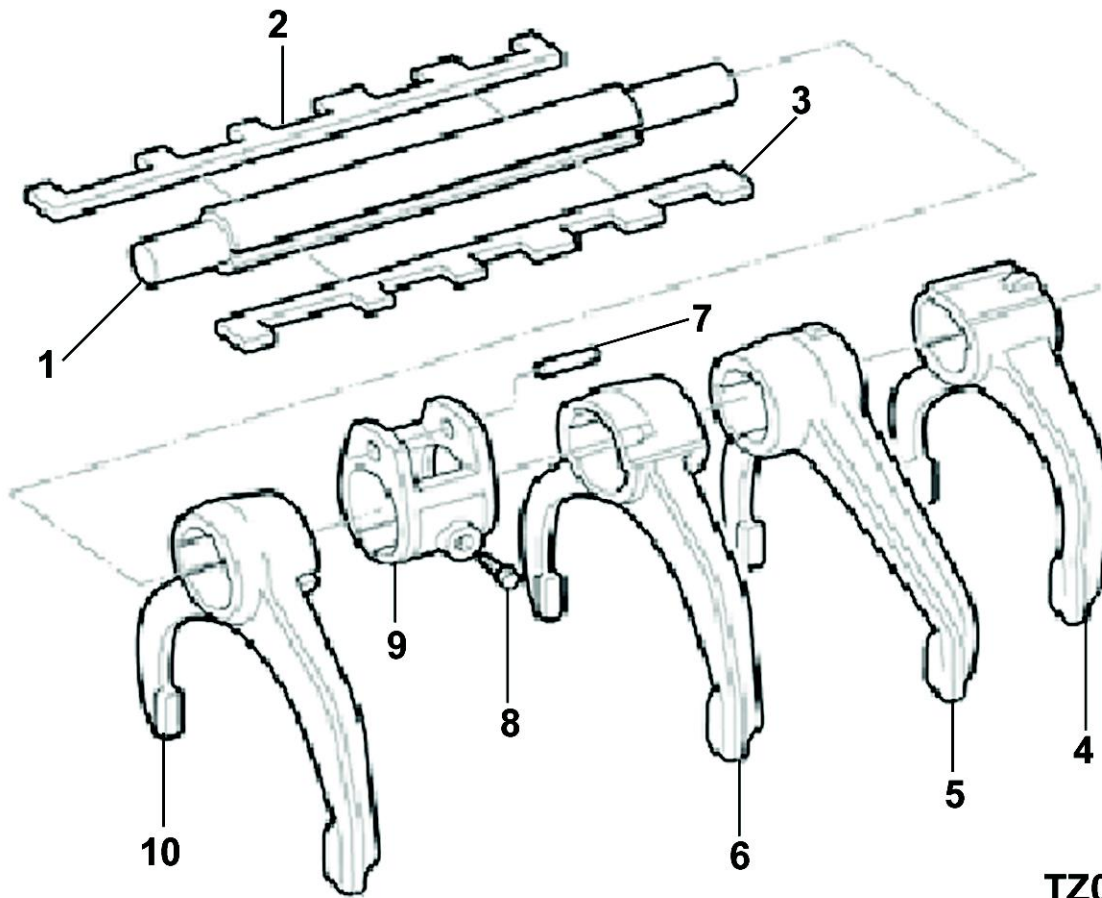

SELECTOR ASSY.

Item	Current Part	Description	Replaced Part	Qty.	Notes	Kits/Assys Where Needed
0	U8875938	SELECTOR ASSY.		1		
1	8874835	SELECTOR SHAFT		1		
2	8876394	SELECTOR KEY		1		
3	8876395	INTERLOCK KEY		1		
4	8875503	FORK REVERSE		1		
5	8882620	FORK 1ST/2ND	8880805	1		
6	8882619	FORK 3RD/4TH	8875501	1		
7	X8870277	DOWEL		1		
8	8873691	SCREW		1	M10X23 HEX HD	
9	8874755	SELECTOR BLOCK		1		
10	8875500	FORK 5TH/6TH		1		

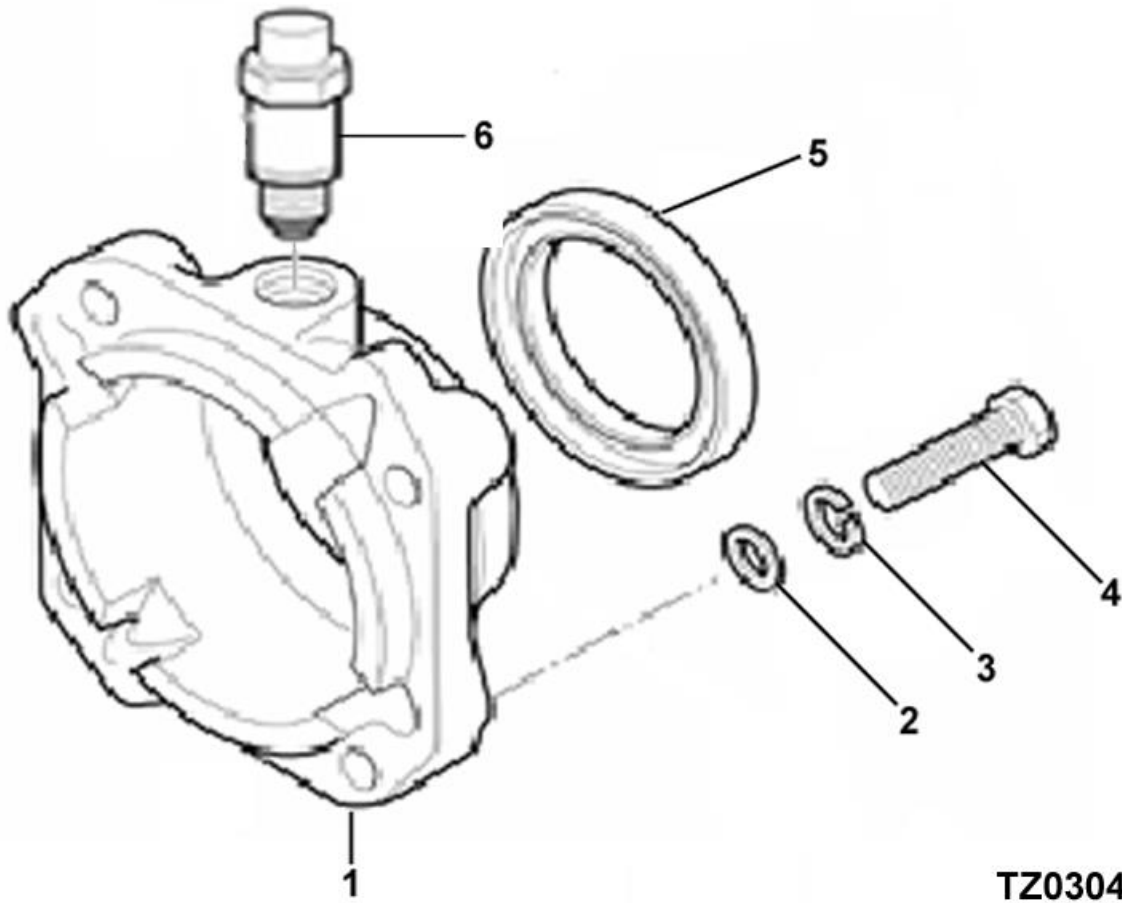

TZ0304

SPEEDO HOUSING

Item	Current Part	Description	Replaced Part	Qty.	Notes	Kits/Assys Where Needed
0	U8872599	SPEEDO HOUSING ASSY.		1		
1	8877754	SPEEDO HOUSING		1		
2	GX11245	WASHER PLAIN		1	M10	
3	GMX-3-1001	SPRING WASHER		1	M10	
4	GMX-8-1020	SCREW		1	M10X35	
4	GMX-8-1091	SCREW		2	M10X30 HEX FLG HD	
4	GMX-8-1093	BOLT		1	M10X45 HEX FLG HD	
5	X13711	OIL SEAL		1		
6	X8883715	SPEEDO SENSOR	GX8882394	1		

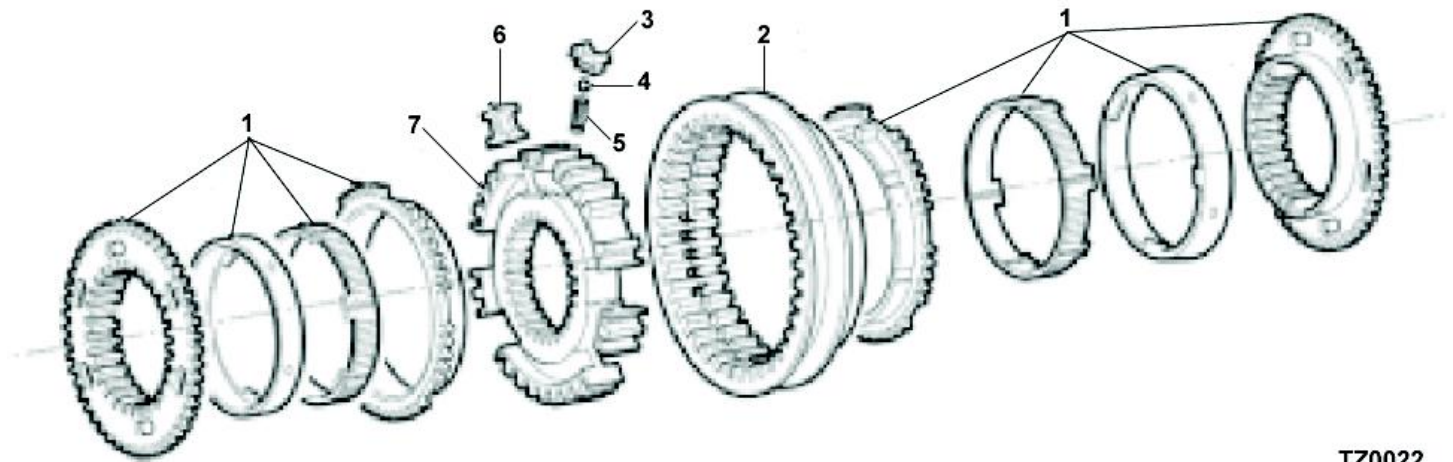

TZ0022

SYNCHRO PACK D.C.1ST/2ND

Item	Current Part	Description	Replaced Part	Qty.	Notes	Kits/Assys Where Needed
1	T20994	SYNCHRO PACK		2		
2	8882198	SLIDING SLEEVE		1		
3	8881516	DETENT POPPET		3		
4	8881515	BALL		3		
5	8881514	SPRING		3		
6	8881513	BLOCK RETAINER		3		
7	8881512	HUB		1		

Copyright Eaton Corporation, 2009.
Eaton hereby grants their customers,
vendors, or distributors permission to
freely copy, reproduce and/or distribute
this document in printed format. It may
be copied only in its entirety without
any changes or modifications. THIS
INFORMATION IS NOT INTENDED FOR
SALE OR RESALE, AND THIS NOTICE
MUST REMAIN ON ALL COPIES.

