

Eaton Fuller® Heavy-Duty Transmissions TRIG0070

October 2007

RTLO-11610B	RTLO-15610B	RTLO-18913A	RTLOF-14610B-T2	RTLOF-16918B
RTLO-11610B-T2	RTLO-15610B-T2	RTLO-18913A-T2	RTLOF-14613B	RTLOF-16918B-T2
RTLO-12610B	RTLO-16610B	RTLO-18918B	RTLOF-14618A	RTLOF-17610B
RTLO-12610B-T2	RTLO-16610B-T2	RTLO-18918B-T2	RTLOF-14713A	RTLOF-17610B-T2
RTLO-12713A	RTLO-16618A	RTLO-20913A	RTLOF-14718B	RTLOF-18610B
RTLO-12913A	RTLO-16713A	RTLO-20918B	RTLOF-14913A	RTLOF-18718B
RTLO-13610B	RTLO-16713A-T2	RTLO-20918B-T2	RTLOF-14918B	RTLOF-18913A
RTLO-13610B-T2	RTLO-16718B	RTLO-22918B	RTLOF-14918B-T2	RTLOF-18913A-T2
RTLO-14610A	RTLO-16913A	RTLOC-16909A-T2	RTLOF-15610B	RTLOF-18918B
RTLO-14610B	RTLO-16913A-T2	RTLOF-11610B	RTLOF-15610B-T2	RTLOF-18918B-T2
RTLO-14610B-T2	RTLO-16918B	RTLOF-11610B-T2	RTLOF-16610B	RTLOF-20913A
RTLO-14613B	RTLO-16918B-T2	RTLOF-12610B	RTLOF-16610B-T2	RTLOF-20918B
RTLO-14618A	RTLO-17610B	RTLOF-12610B-T2	RTLOF-16618A	RTLOF-20918B-T2
RTLO-14713A	RTLO-17610B-T2	RTLOF-12713A	RTLOF-16713A	RTLOF-22918B
RTLO-14718B	RTLO-18610B	RTLOF-12913A	RTLOF-16713A-T2	RTLOFC-16909A-T2
RTLO-14913A	RTLO-18610B-T2	RTLOF-13610B	RTLOF-16718B	
RTLO-14918B	RTLO-18718B	RTLOF-13610B-T2	RTLOF-16913A	
RTLO-14918B-T2	RTLO-18718B-T2	RTLOF-14610B	RTLOF-16913A-T2	



Powering Business Worldwide

BACKED BY

Roadranger

SUPPORT

Warnings and Cautions

The description and specifications contained in this service publication are current at the time of printing.

Eaton Corporation reserves the right to discontinue or modify its models and/or procedures and to change specifications at any time without notice.

Important Notice

Any reference to brand name in this publication is made as an example of the types of tools and materials recommended for use and should not be considered an endorsement. Equivalents may be used.

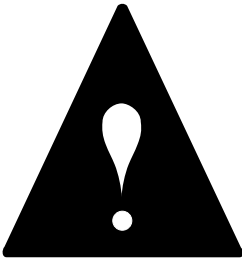
<p>This symbol is used throughout this manual to call attention to procedures where carelessness or failure to follow specific instructions may result in personal injury and/or component damage.</p>		▲ WARNING
<p>Departure from the instructions, choice of tools, materials and recommended parts mentioned in this publication may jeopardize the personal safety of the service technician or vehicle operator.</p>		▲ CAUTION
		▲ IMPORTANT
		<p>Failure to follow indicated procedures creates a high risk of personal injury to the servicing technician.</p>
		<p>Failure to follow indicated procedures may cause component damage or malfunction.</p>
		<p>Highly recommended procedures for proper service of this unit.</p>
		<p>Note: Additional service information not covered in the service procedures.</p>
		<p>Tip: Helpful removal and installation procedures to aid in the service of this unit.</p>

Always use genuine Eaton replacement parts.

Every effort has been made to ensure the accuracy of all information in this guide. However, Eaton makes no expressed or implied warranty or representation based on the enclosed information.

Warnings and Cautions

Warnings and Cautionsi

General Information

How to Use This Manual1

Installation Requirements

Requirements2
 Space Requirements3
 10-speed Valve Location3
 9- / 13-speed Valve Location5
 18-speed Valve Location6
 Lubrication Requirements8
 Air Supply Requirements10
 9-speed Pneumatic Diagrams11
 10-speed Pneumatic Diagrams12
 13-speed Pneumatic Diagrams13
 18-speed Pneumatic Diagrams14
 Transmission Mounting Requirements15
 Mounting Transmission to Engine16
 Using Rear Supports17
 Typical Rear Support Designs17

Electrical Requirements

Top 2 Valve Electrical Requirements 18
 Wiring Diagram OEM Responsibility 19
 Caterpillar Programming 19
 Detroit Diesel Programming 21

Line Inspection

Line Inspection and Road Test Instructions 26
 Line Inspection Form 27
 Troubleshooting 28

Appendix

Wiring Diagrams 29
 Caterpillar 29
 Detroit Diesel 31
 Torque Specifications 33
 Suggested Tools 34
 Related Publications 34
 Application Forms 35

How to Use This Manual

This Eaton Publication is intended to be a reference guide for the installation of all Top 2 series transmissions. As much general vehicle and transmission information has been given for covering the wide range of applications. This information benefits the OEM installer by providing the correct installation procedures to ensure the utmost in satisfactory operation and long service life. For specific engine information, contact engine OEM.

Specific OEM installation requirements are shown in each section.

Failure to adhere to Eaton installation requirements may effect transmission performance and/or warranty coverage.

Top 2 transmissions installed at OEM facilities must meet the requirements for standard manual Eaton Fuller transmissions outlined in Form FUL-169. Applications outside of these requirements must be approved by Eaton Engineering using Form FUL-170.

All information contained in this manual was accurate at the time of printing. With each new application, engine manufacturers should be contacted to make sure desired engines are compatible with the Top 2 system.

Requirements

All Top 2 transmission systems installed at OEM facilities must meet the requirements for standard manual Eaton Fuller Transmissions outlined in Form FUL-169 and be approved using the Eaton Automated Transmission Application Approval Form FUL-170. Both forms can be found in the Appendix.

1. Air Dryer Requirements - A high quality commercially available vehicle air dryer is required to be used in conjunction with Top 2 systems.
2. Clutch Requirements - Spring dampened clutches are required for all applications.
3. Electrical Requirements - All wires are to be a minimum of 16 gauge GXL.
4. Integral Coolers - Reference Form FUL-169 Note 2 for transmission cooler requirements.
5. Line Inspection - All Eaton Top 2 transmission systems installed at OEM plants must pass the requirements outlined in the "Line Inspection Form" prior to shipment.
6. Lubrication Requirements - Transmission oil should meet specifications as outlined in TCMT-0020 (Roadranger Products Approved Lubricants) and TCMT-0021 (Roadranger Products Lubrication Manual).
7. Power Connections - All ECMs will have redundant power and ground pins. If no redundancy is available, a relay connection similar to the one on page 29.
8. Valve Spatial Requirements - The Top 2 solenoid valve requires a minimum of 2" clearance from any high temperature devices (i.e. exhaust crossover pipes).

Space Requirements

10-speed Valve Location

Note: Refer to “Transmission Mounting Requirements” for Valve Spatial Requirements.

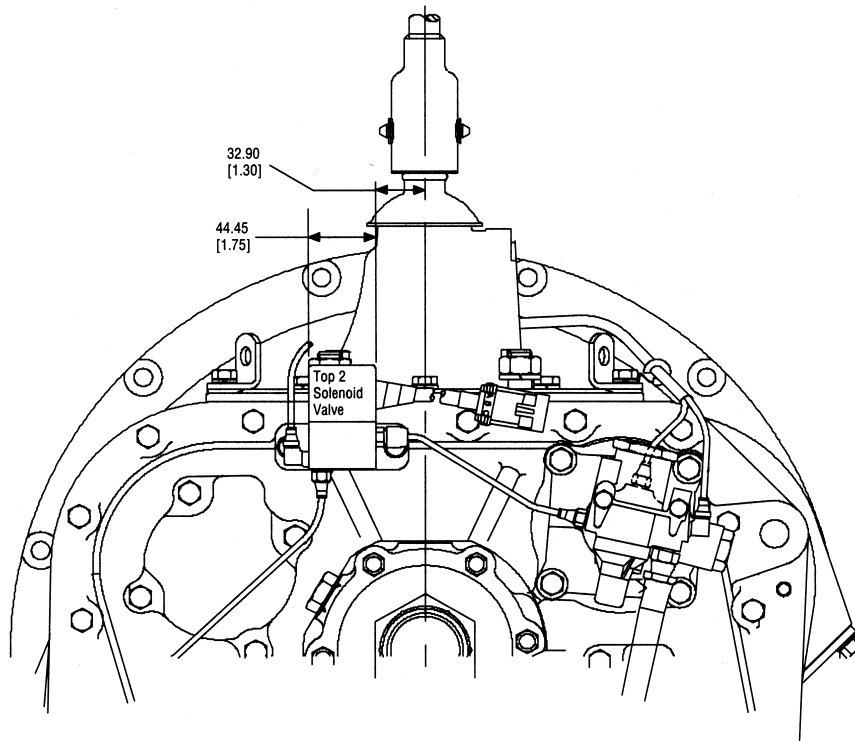

Installation Requirements

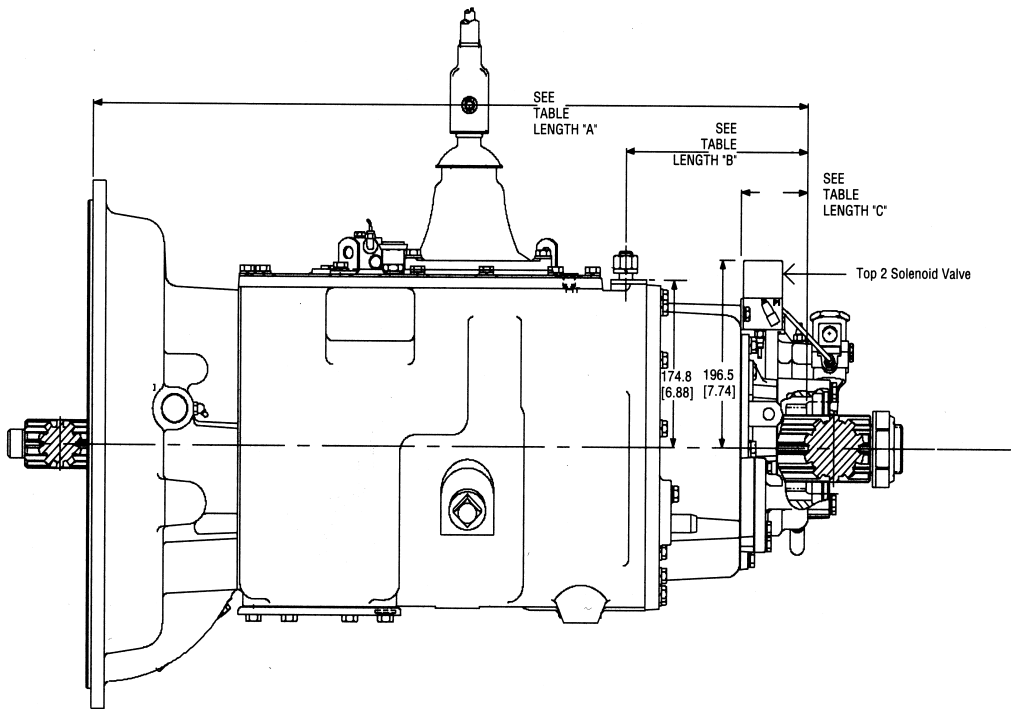

Installation
Requirements

MODEL	LENGTH "A"	LENGTH "B"	LENGTH "C"
11610	815.1 (32.09)	200.4 (7.89)	67.8 (2.67)
12610	815.1 (32.09)	200.4 (7.89)	67.8 (2.67)
13610	815.1 (32.09)	200.4 (7.89)	67.8 (2.67)
14610	823.2 (32.41)	208.5 (8.21)	75.9 (2.99)
15610	823.2 (32.41)	208.5 (8.21)	75.9 (2.99)
16610	823.2 (32.41)	208.5 (8.21)	75.9 (2.99)

9- / 13-speed Valve Location

Note: Refer to "Transmission Mounting Requirements" for Valve Spatial Requirements.

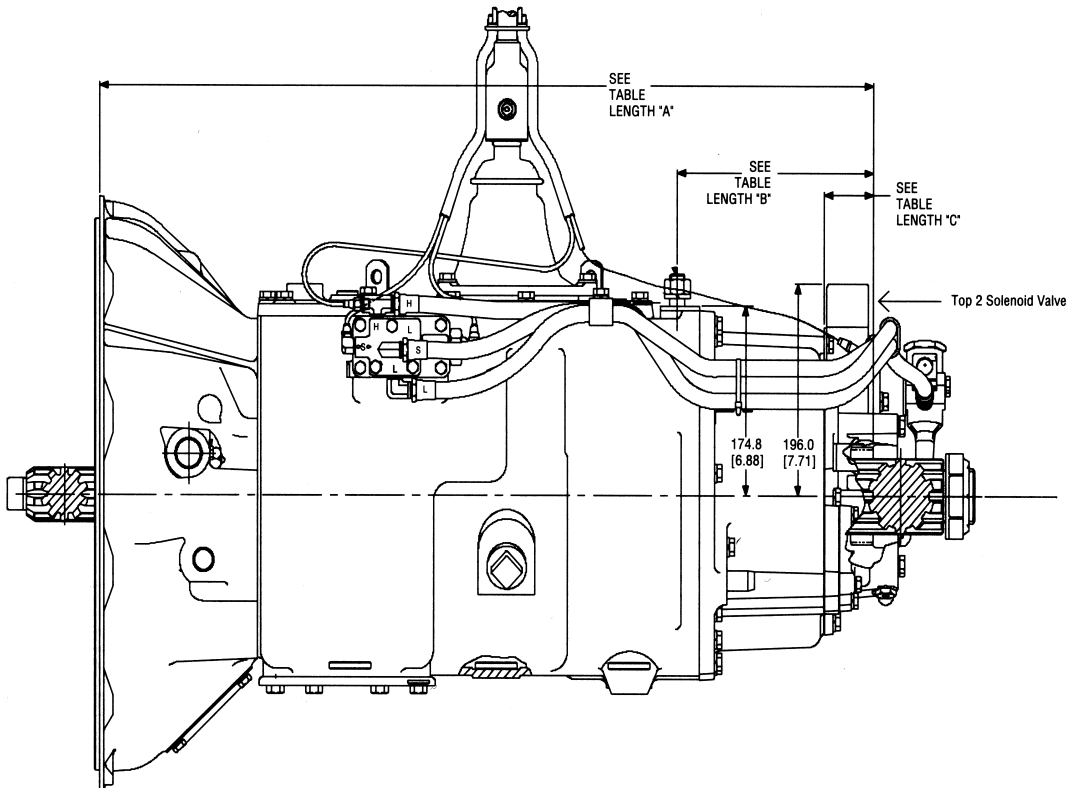
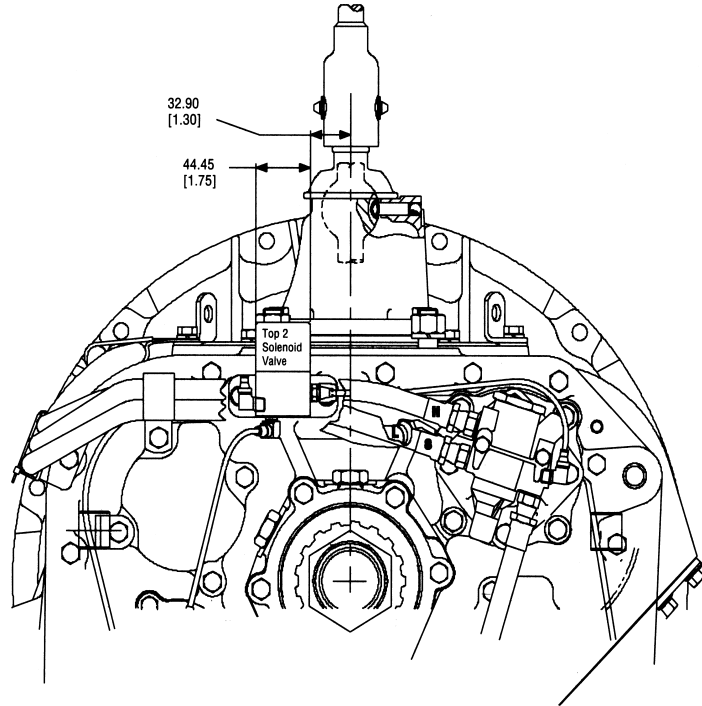

MODEL	LENGTH "A"	LENGTH "B"	LENGTH "C"
12713	815.1 (32.09)	200.4 (7.89)	43.9 (1.73)
14713	823.2 (32.41)	208.5 (8.21)	51.8 (2.04)
16713	823.2 (32.41)	208.5 (8.21)	46.5 (1.83)
12913	840.7 (33.09)	226.1 (8.9)	69.6 (2.74)
14913	840.7 (33.09)	226.1 (8.9)	69.6 (2.74)
18913	840.7 (33.09)	226.1 (8.9)	69.6 (2.74)

18-speed Valve Location

Note: Refer to "Transmission Mounting Requirements" for Valve Spatial Requirements.

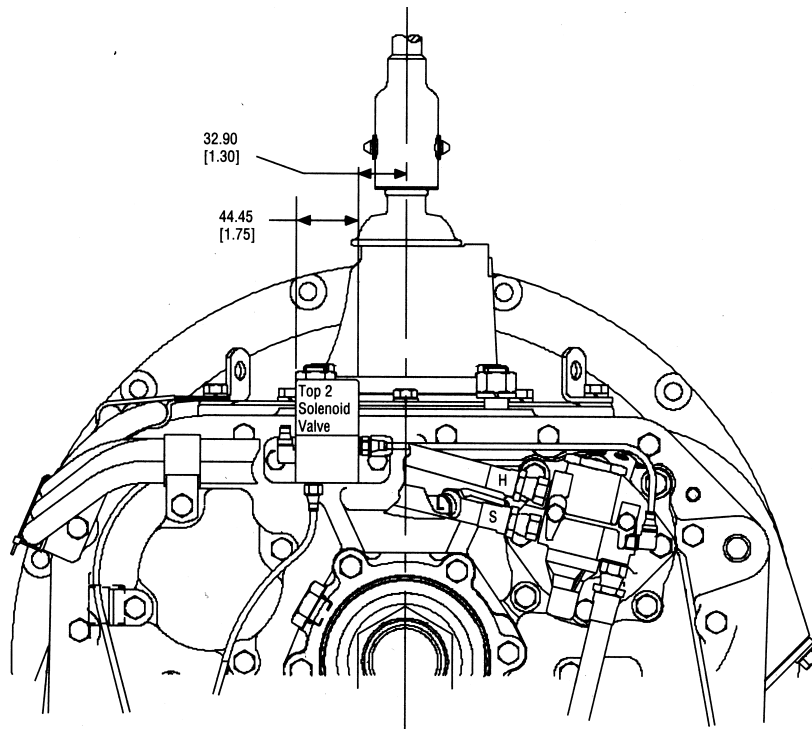

Installation Requirements

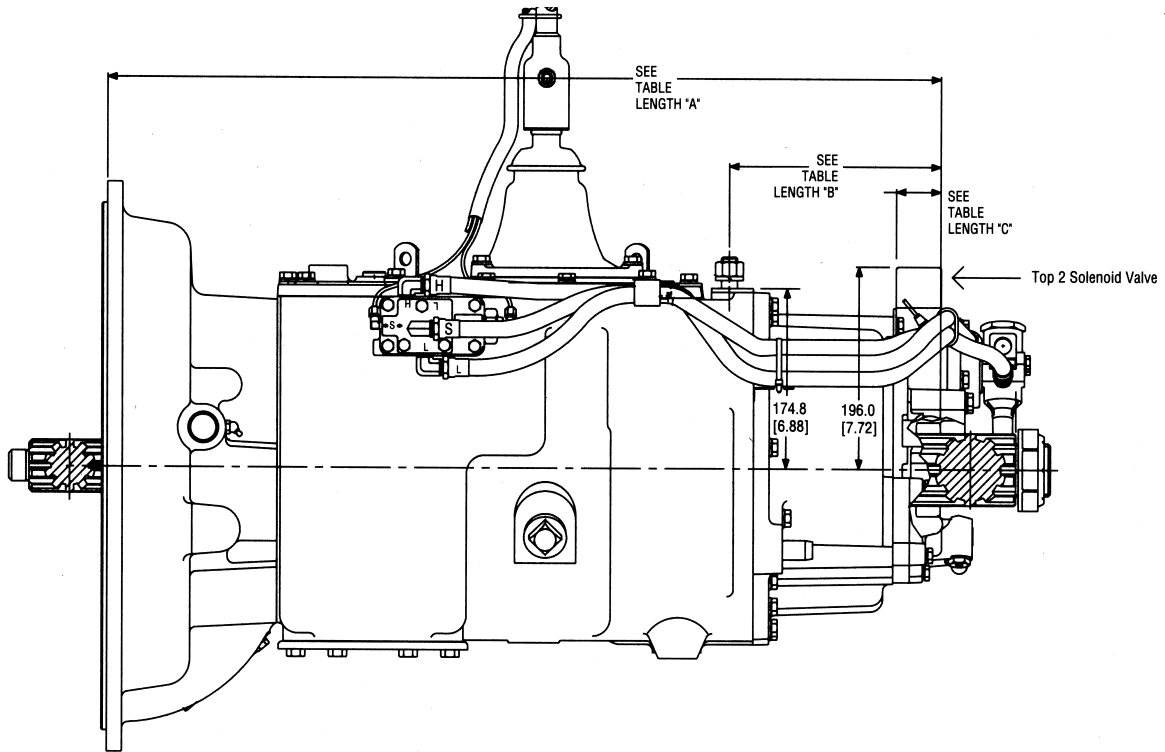

MODEL	LENGTH "A"	LENGTH "B"	LENGTH "C"
14918	840.7 (33.09)	226.1 (8.9)	69.6 (2.74)
16918	840.7 (33.09)	226.1 (8.9)	69.6 (2.74)
18918	840.7 (33.09)	226.1 (8.9)	69.6 (2.74)
20918	840.7 (33.09)	226.1 (8.9)	69.6 (2.74)
22918	840.7 (33.09)	226.1 (8.9)	69.6 (2.74)

Lubrication Requirements

Eaton Fuller transmissions are designed so the internal parts operate in a bath of lubricant circulated by the motion of gears and shafts. Thus, all parts will be amply lubricated if these procedures are closely followed:

- Use Roadranger CD50 or equivalent E500 synthetic per Eaton publication TCMT-0021.
- When adding lubricant, types and brands of lubricant should not be mixed because of possible incompatibility.
- Use clean lubricant and clean containers when filling the transmission. Containers that have been used for antifreeze or water should not be used for transmission lubricant.
- Additives and friction modifiers are not recommended for use in Eaton Fuller transmissions.

Recommended Lubricant

Type	Grade (SAE)	Temperature
Roadranger CD50 Transmission Fluid	50	ALL

Includes all Roadranger Approved comparable synthetic lubricant.

Proper Lubricant Level

Transmission Capacity

9-Speed	28 pints (13.2 liters)
10-Speed	26 pints (12.3 liters)
13/18-Speed	28 pints (13.2 liters)

Note: Failure to adhere to Eaton Installation Requirements may effect transmission performance and /or warranty coverage.

Note: The quantity for proper fill level will vary from model to model.

Make sure lubricant is level with fill hole opening. Because you can reach lubricant with your finger does not mean lubricant is at the proper level. (On heavy duty transmissions, one inch of lubricant level equals about 8 pints of oil).

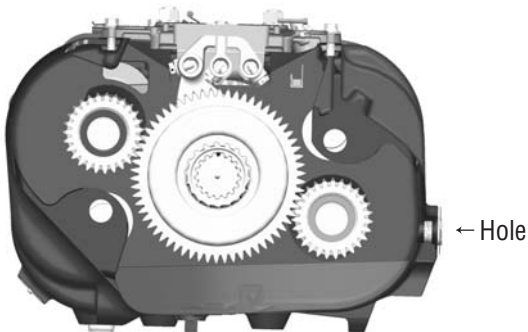

Improper Oil Level

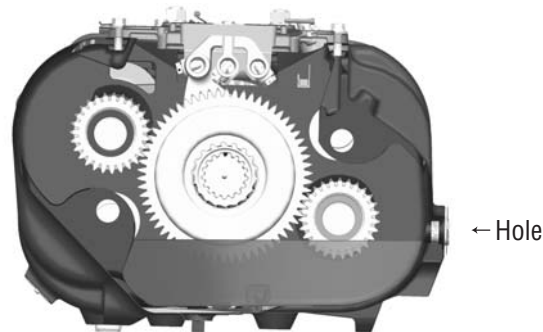

Proper Oil Level

Proper Lubrication Levels as Related to Transmission Installation Angles

If the transmission operating angle is more than 12 degrees, improper lubrication can occur. The operating angle is the transmission mounting angle in the chassis plus the percent of upgrade (expressed in degrees).

For example: If you have a 4 degree transmission mounting angle, then 8 degrees (or 14 percent of grade) is equal to the limit of 12 degrees. If you have a 0 degree mounting angle, the transmission can be operated on a 12 degree (21 percent) grade.

Note: The chart shows the effect a lubricant level 1/2" below normal can have on safe operating angles. Operating the vehicle 1/2" low on lubricant reduces the safe degree of grade by approximately 3 degrees (5.5 percent).

Proper Lubrication Levels are Essential!

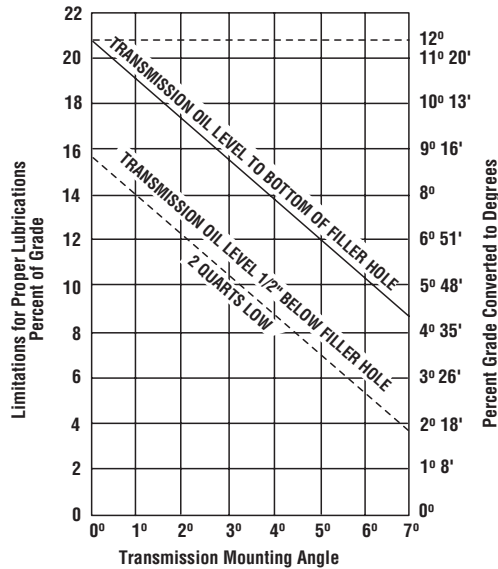

Dotted line showing "2 Quarts Low" is for reference only.
Not recommended.

Note: For transmissions with cooler's installed, make sure lubricant is level with fill hole opening, run the truck, stop and check lubricant level. Lubricant must be level with fill hole.

Air Supply Requirements

1. It is required to use a high quality commercially available air dryer in the air supply line before the transmission.
2. Minimum air requirement for the transmission is 65 PSI.
3. A minimum of 1/4" diameter air supply line is required.
4. The transmission air supply is required to be routed from the air tank, which supplies air to either the front or rear vehicle service brakes, with a gauge indicator in the cab.
5. Transmission airlines should not be routed or attached at the bottom air tank fittings to avoid any chances of introducing moisture into the airline.
6. Care should be used when routing the air supply to avoid kinks and close contact to heat sources.
7. The transmission air supply must be connected to the air filter/regulator mounted on the range cylinder cover.

Note: The air filter/regulator must not be removed during installation.

8. Air additives such, as alcohol devices should not be permitted to enter the transmission air supply. Additives could cause damage to air system components, which could lead to degraded transmission performance.

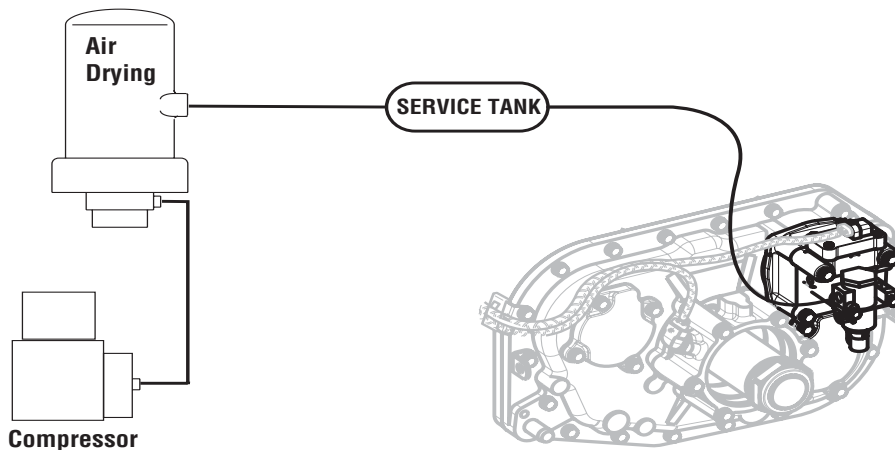

CAUTION

**Do not tie wrap air line
to wire harness on transmission**

9-speed Pneumatic Diagrams

Note: Only solid lines are connected by the OEM. Dashed lines are already plumbed.

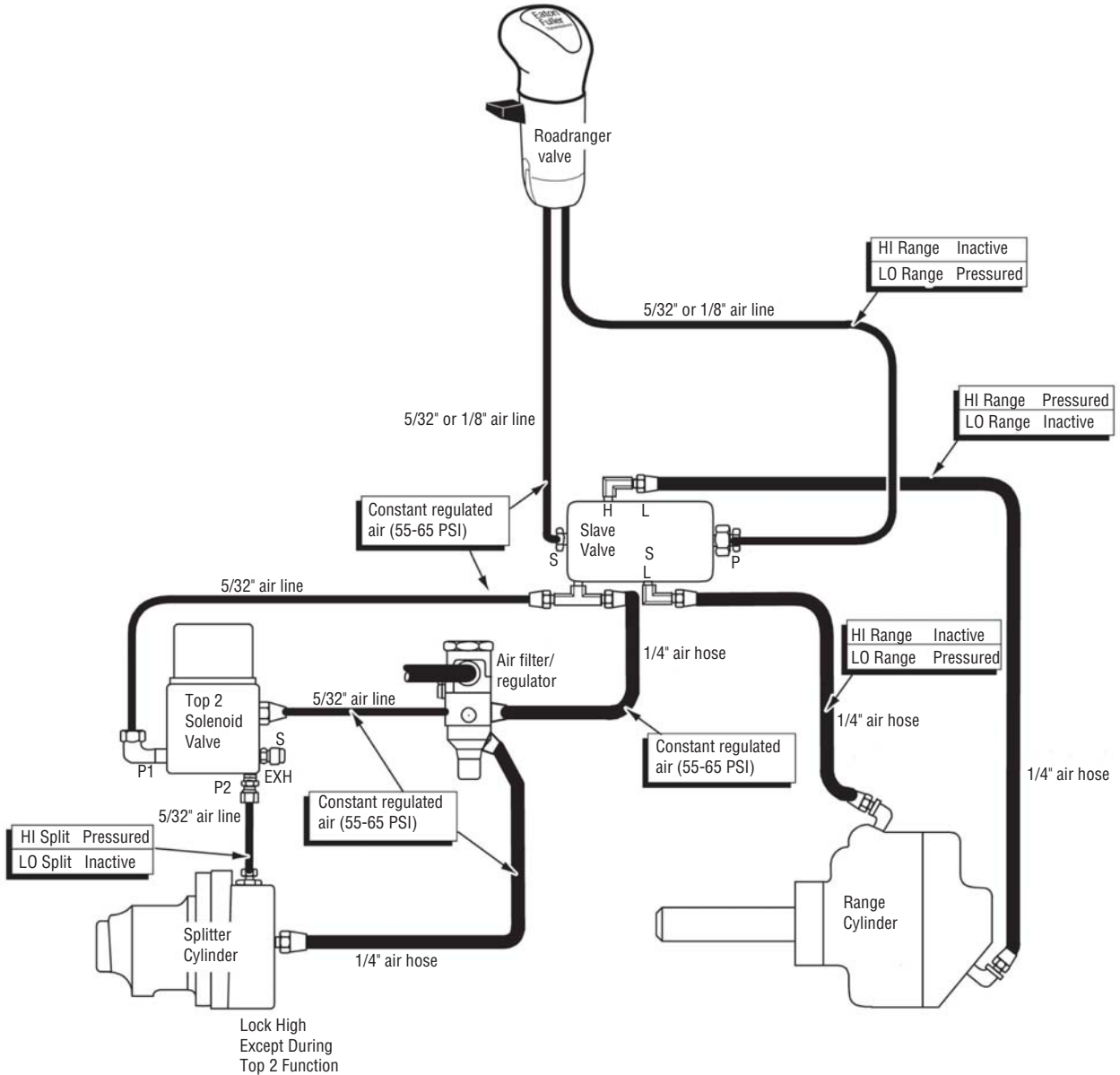

10-speed Pneumatic Diagrams

Note: Only solid lines are connected by the OEM. Dashed lines are already plumbed.

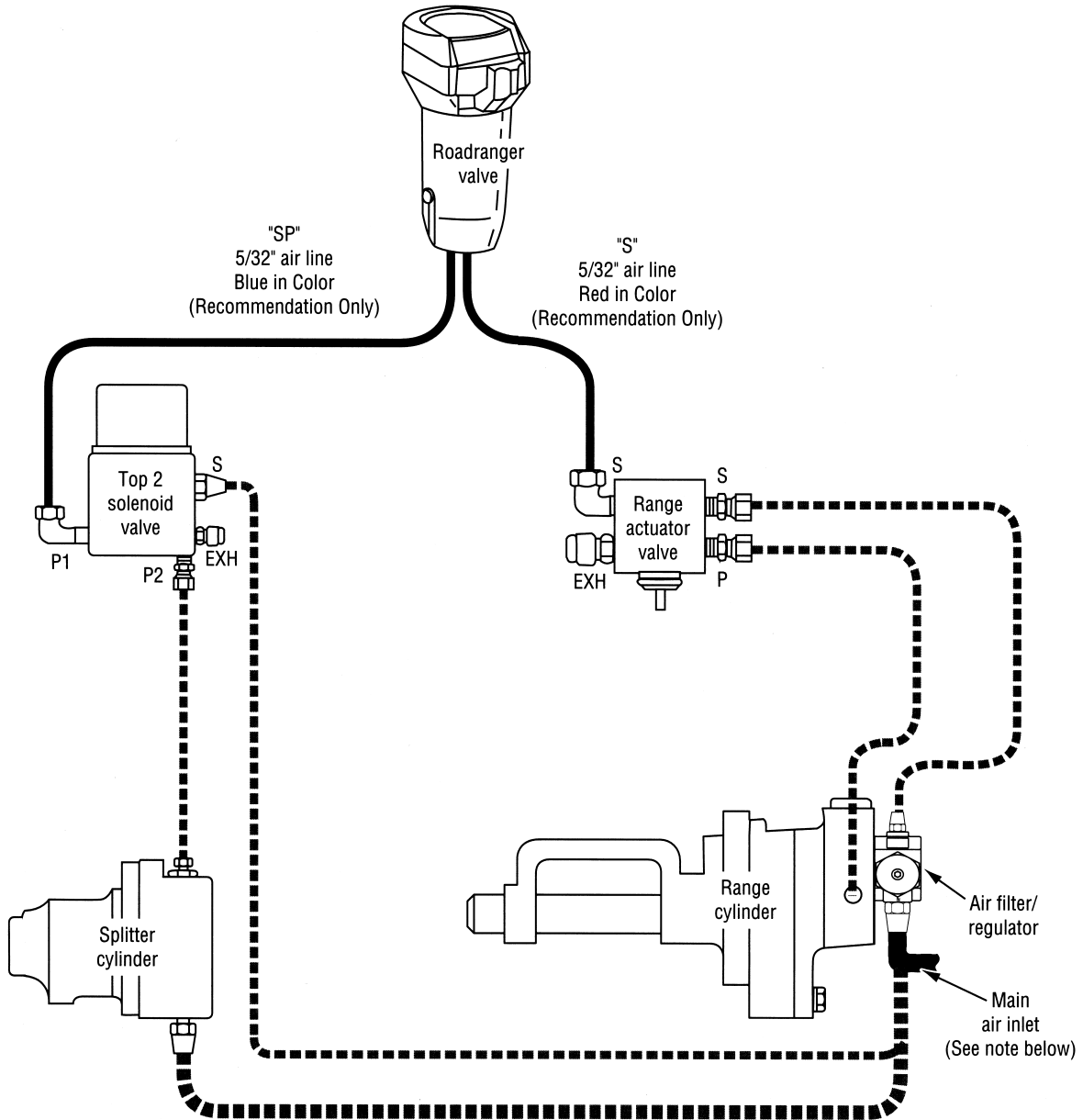

13-speed Pneumatic Diagrams

Note: Only solid lines are connected by the OEM. Dashed lines are already plumbed.

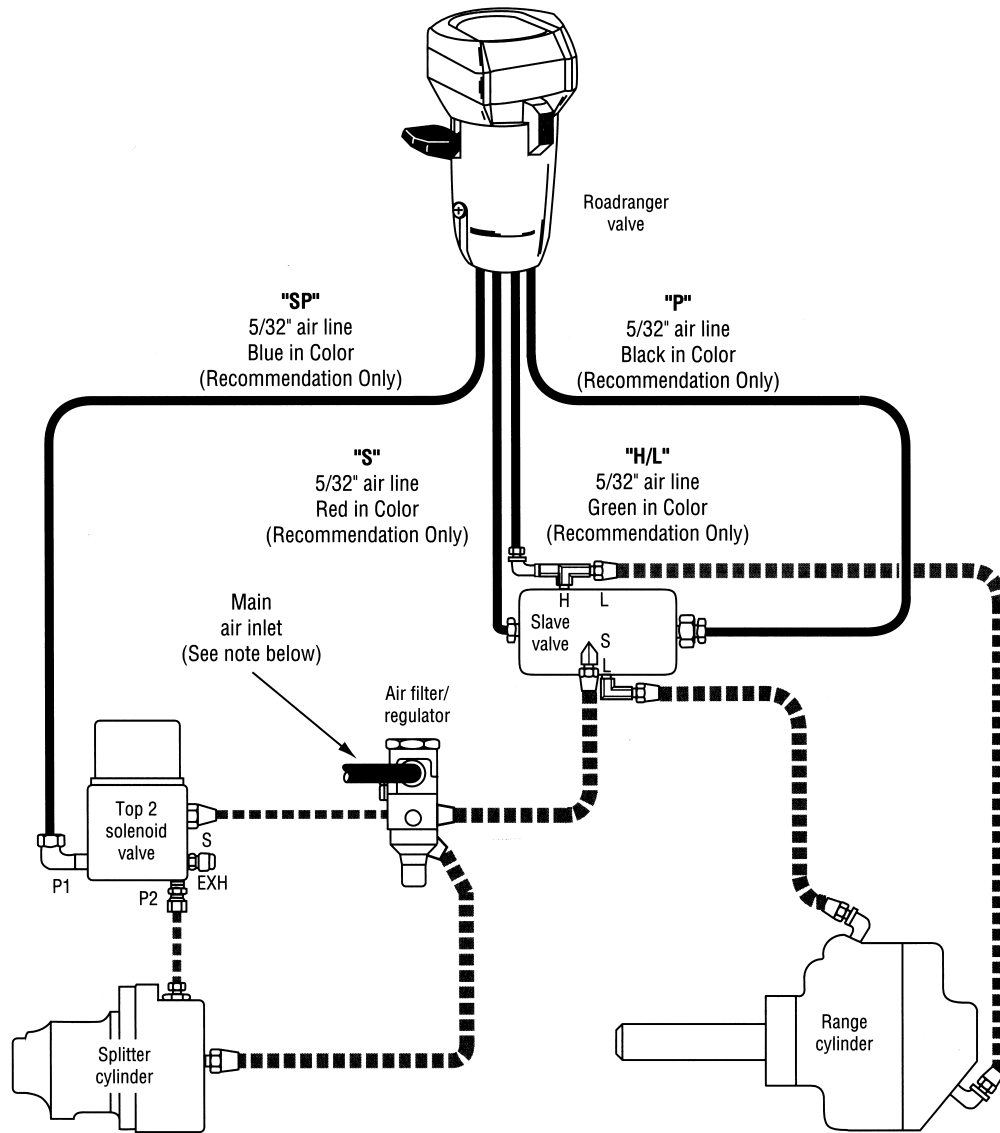

NOTE: Main air inlet is 1/4" I.D. hose connected to either of the main air tanks.

18-speed Pneumatic Diagrams

Note: Only solid lines are connected by the OEM. Dashed lines are already plumbed.

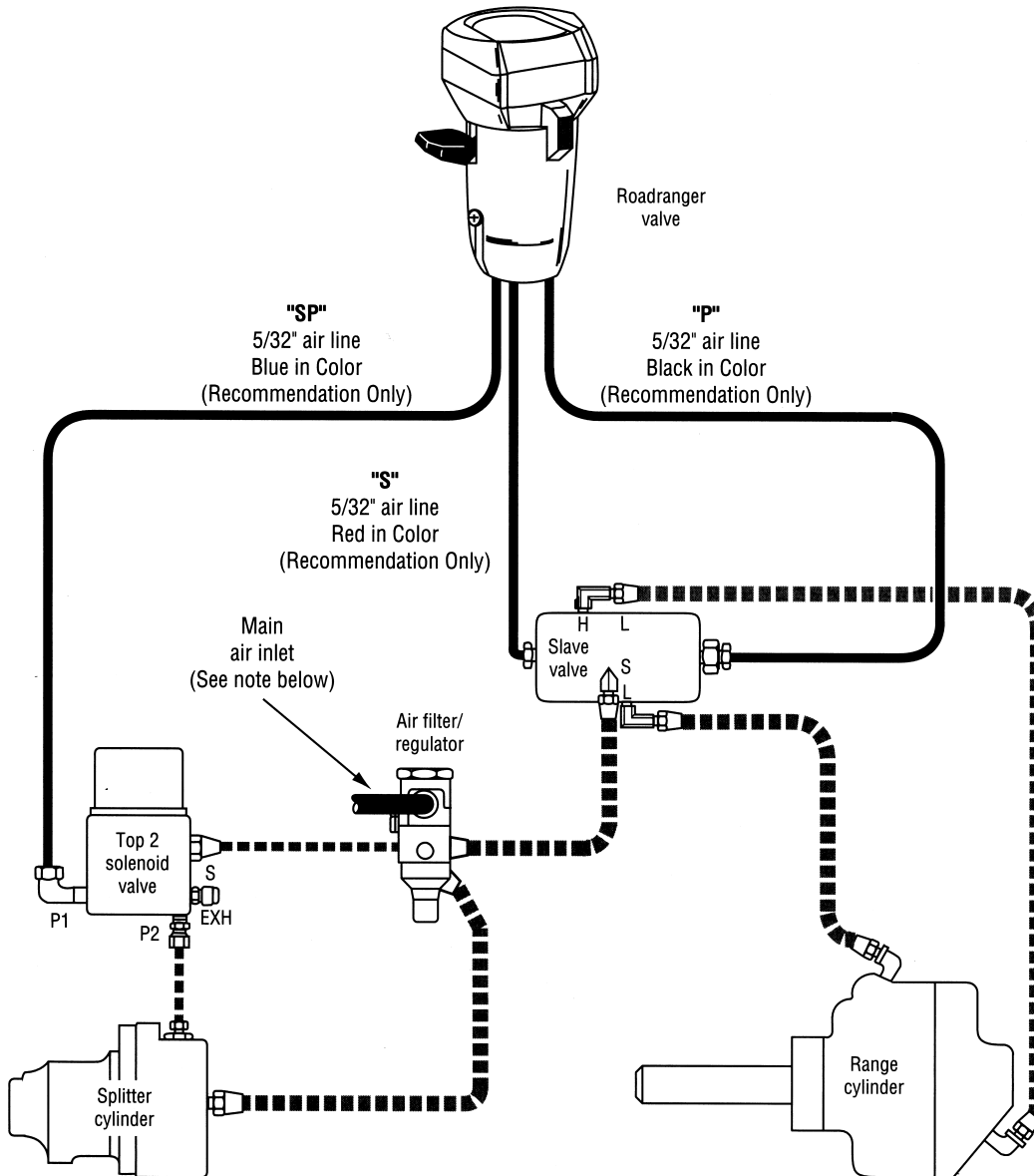

Installation
Requirements

Transmission Mounting Requirements

Handling

Handle the transmission carefully to avoid damage to the transmission components and surrounding vehicle components.

1. Use a hoist or transmission jack that permits precise control of transmission movement during installation.

Transmission Preparations

Always remove banding and protective wrapping from the transmission and inspect for shipping damage as soon as possible upon receiving.

2. If a thread-in electronic speedometer system is used, tighten sensor or sensor lock nut to 35 lbs-ft. [47 N•m], (3/4-16 threads). If a push-in electronic speedometer system is used, Eaton P/N 14142 (O-ring) and Eaton P/N 71206 (silicon lubricant) are used to seal the sensor.
3. To remove, reposition, or replace rear bearing cover, apply Eaton Sealant P/N 71205 or equivalent to threads and tighten main shaft rear bearing cover capscrews to 35-45 lbs-ft. [47-61 N•m] (3/8-16).

Output Yoke/Flange Installation

Note: The output yoke/flange is supplied with the transmission. If the output Yoke/flange must be replaced, the following procedure should be followed. (For detailed instructions, refer to the proper transmission model service manual.)

Select the proper output yoke per specified application, remove plastic cover, and inspect the slinger (gold anodized ring) and seal surface for damage or contamination. Do not use the yoke/flange if the slinger or seal surface is damaged such as dents, nicks, or scratches.

1. Prior to installation, remove all contamination such as styrofoam particles, dust, dirt, or rust in the machined surface of the yoke/flange.
2. Place the yoke/flange over the transmission output shaft end and rotate it to line up the splines. Take care not to bump any machined surface of the yoke/flange against the output shaft. Push the yoke all the way onto the output shaft and onto the seal with one continuous motion.
3. Thread the tail shaft nut onto the tailshaft until nylon insert is engaged on the tailshaft thread. Secure yoke/flange and tighten the tailshaft nut to 450-500 lbs-ft. [610-678 N•m].

Mounting Transmission to Engine

Use the two transmission lifting eyes provided. The lifting eye position must not be changed on the transmission.

Note: For lifting eye and sensor retaining bolt locations, see Appendix. These bolts can not be used for brackets or for any other purpose.

1. Use a two point lift chain or transmission jack with a minimum capacity of 1500 lbs.
2. Inspect the engine to transmission mating surfaces for damage or debris prior to installation. Make sure engine flywheel housing face, transmission clutch housing face, input shaft, etc. are free of paint, debris, rust, and any type of damage before installation.
3. Input Shaft To Clutch Alignment: The transmission is shipped from Eaton with the transmission in gear. The transmission must be in gear in order to rotate the input shaft by turning the output shaft/yoke.
4. Adjust the lift chain or transmission jack to obtain the same relative angle as the engine. The face of the engine flywheel housing and the face of the transmission clutch housing must be parallel during installation. If the transmission is properly aligned and the clutch is installed properly, very little force is required to slide the input shaft through the clutch and into the pilot bearing.
5. If interference is encountered, move the transmission away from the engine to investigate the cause. The use of excessive force to overcome misalignment may cause damage to the transmission input shaft and the clutch.
6. Rotate the output shaft/yoke while sliding the input shaft into the clutch to line up the splines.
7. Once the transmission is seated against the engine flywheel housing, align the clutch housing bolt holes with the engine flywheel housing bolt holes and install all capscrews and tighten finger tight.

Note: The clutch housing must be flush against the engine flywheel housing before tightening any capscrews. Do not use the capscrews to seat housing.

8. Tighten four capscrews at 90° intervals around the clutch housing, then tighten the remaining transmission mounting capscrews using the recommended torque specifications.

Note: Do not tighten any mounting capscrews until all capscrews have been installed and finger tightened. Do not remove the transmission support chain or jack until all mounting bolts have been tightened.

Using Rear Supports

The OEM is responsible for determining if rear transmission support is required.

1. The transmission nodal mounting pads are approved to be used as a rear engine support location.
2. The OEM is responsible for nodal mount design.
3. Torque transmission nodal mount capscrews (3/4-10 UNC) to 180-190 lbs. ft. [224-258 N•m] of torque

Typical Rear Support Designs

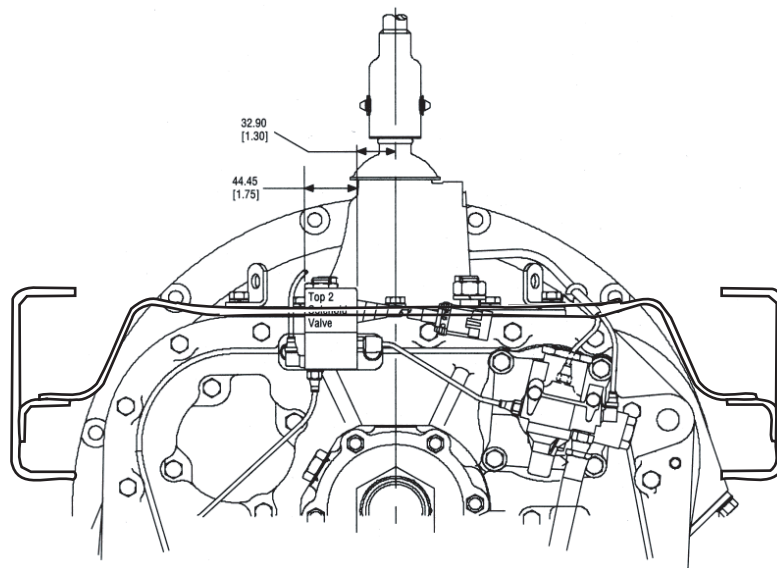
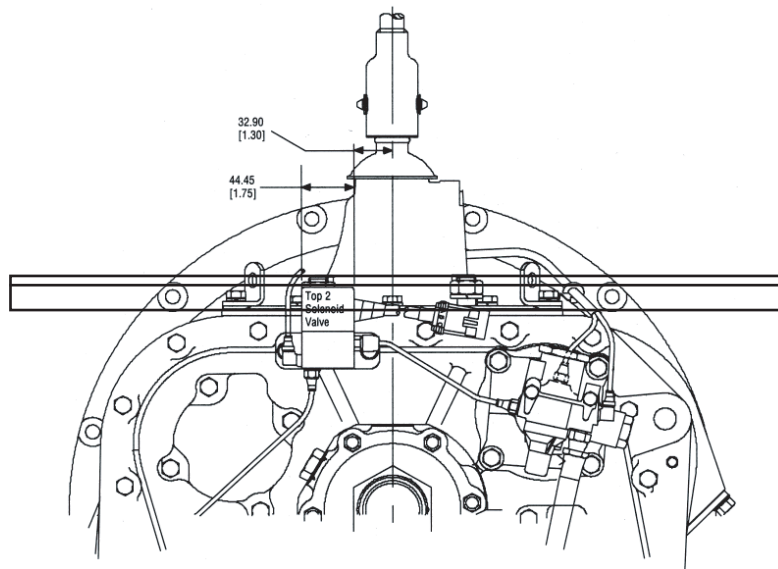

Top 2 Valve Electrical Requirements

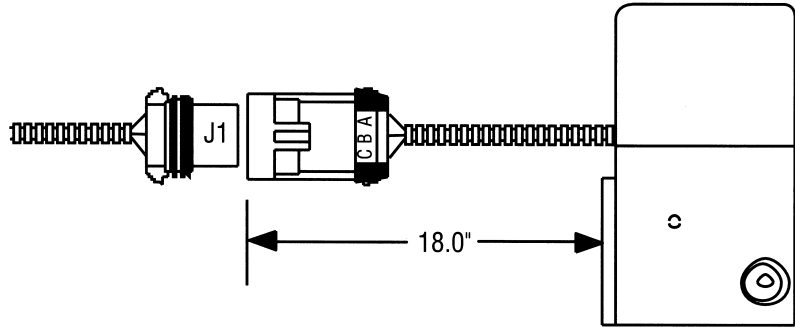

Mating connector description:

Designation	Description	Part Number	Quantity
J1	Connector Body	12110293	1
	Cable Seal	12048086	3
	Terminal	12048074	3
	Secondary	12052845	1

Wiring Diagram OEM Responsibility

Caterpillar Programming

Note: All information on this page is only for a Caterpillar engine.

End-of-Line Programming at the OEM

Caterpillar units will already be programmed with all known features. The features simply need to be enabled. The “VEPS” software allows the OEM to activate / deactivate features.

Programming at the Distributor Site

Contact your Caterpillar representative for programming instructions.

Service Tool ET (Electronic Technician) allows for the activation of the “Eaton Top 2” Transmission Style parameter.

Once the Eaton Top 2 is activated, gear ratios must be programmed as well. Each ratio must be programmed to three decimal places. Those ratios are as follows:

Transmission Model	Top Gear Minus Two Ratio	Top Gear Minus One Ratio	Top Gear Ratio
RTLO-XX610B-T2	1.352	1.000	0.741
RTL-XX710B-T2 RTL-XX910B-T2	1.825	1.351	1.000
RTLO-XX713A-T2 RTLO-XX913A-T2	1.000	0.856	0.730
RTLO-XX718B-T2 RTLO-XX918B-T2	1.000	0.856	0.730
RTLOC-1X909A-T2	1.000	0.856	0.730

Note: “XX” appearing in the transmission model number refers to the “XX” x 100 = Nominal Torque Capacity. For example, RTLO-14610B-T2 has a nominal torque capacity of 14 x 100 or 1400 lbs. ft.

Multi-function Output #7 is programmed as the “Shift Solenoid” in the Output Selections Group.

Multi-function Output #6 is programmed as the “Lockout Solenoid” in the Output Selections Group.

Caterpillar recommends locking out all Eaton Top 2 related parameters after programming has been completed and proper operation has been verified.

Note: After parameters have been locked out, Factory Passwords are required to edit.

Caterpillar Schematic Diagram

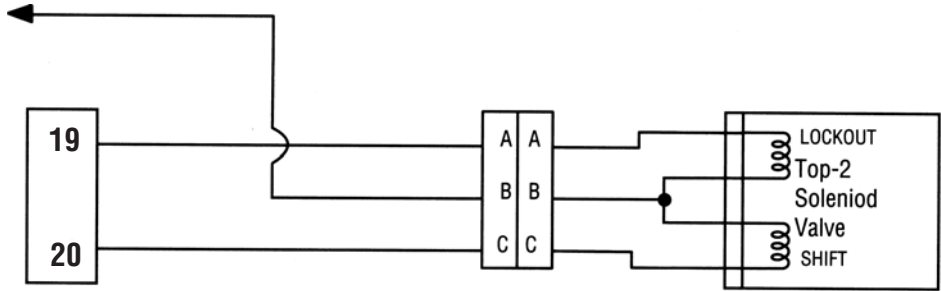

Interconnection Table

From Top 2 Solenoid Valve	To Engine Control Module Connector (P1)	Description
A	19	Lockout
B	none	Engine Ground Stud
C	20	Shift

Caterpillar Wiring Diagram

CATERPILLAR
ECM
CONNECTOR
P1

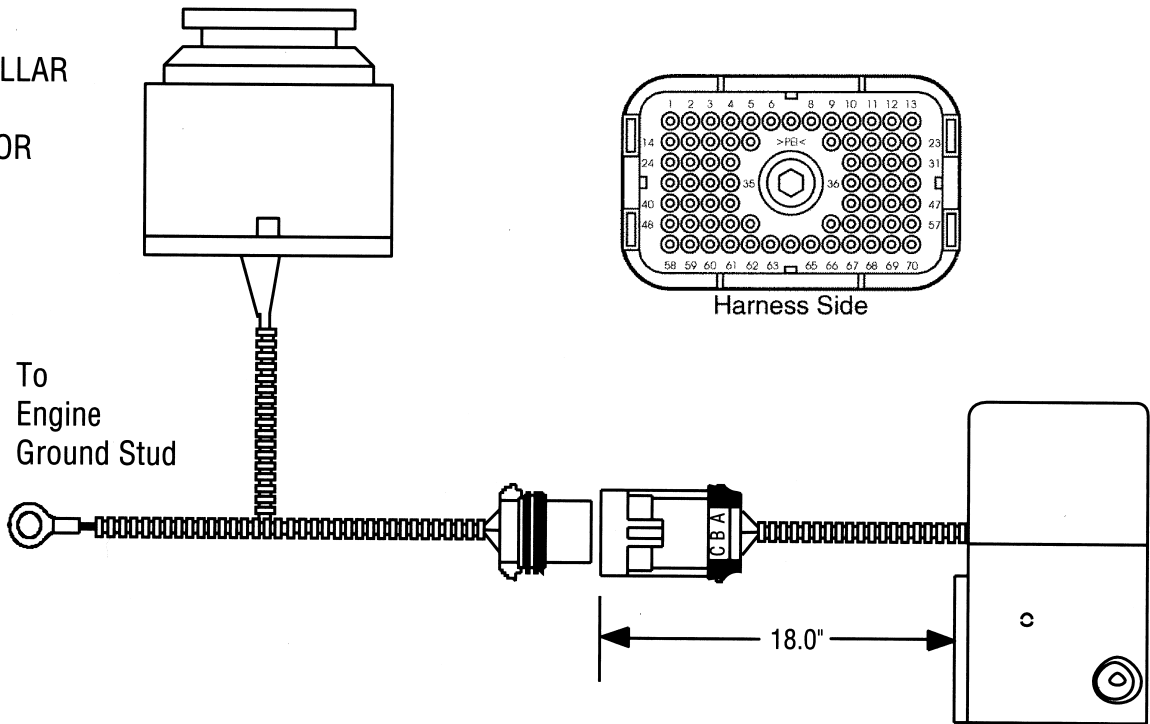

Electrical Requirements

Detroit Diesel Programming

Note: All information on this page is only for a Detroit Diesel engine.

End-of-Line Programming at the OEM

DDEC units will already be programmed with all known features. The features simply need to be enabled. The “VEPS” software allows the OEM to activate / deactivate features or configure individual ECM pins. VEPS can assign any ECM pin to a specific function, as long as the physical function of the pin is compatible. Usually this is automatic with VEPS software, but can be assigned manually as well. This method is used after order entry when the required features are known.

Programming at the Distributor Site

DDEC units are programmed with all features and are setup in a similar fashion to the End-of-Line Programming. The distributor programming station will download the latest software version from the DDC mainframe. The distributor will trace back the wires from the Top 2 solenoids and manually enter in the individual pin numbers as assigned to the “Top 2 Lock-Out Solenoid” and the “Top 2 Shift Solenoid” drivers which then activates the Top 2 feature.

For further information, contact your Detroit Diesel representative.

Programming Information:

DDEC III and IV

Circuit Name	SID	Pin	Connection
Auxiliary Output #1	26	F-3	OEM Vehicle Interface Connector
Auxiliary Output #2	40	A-2	OEM Vehicle Interface Connector
Auxiliary Output #5	53	W-3	Top 2 3-Way Connector
Auxiliary Output #6	54	X-3	Top 2 3-Way Connector
Auxiliary Output #7	55	Y-3	Top 2 3-Way Connector
Auxiliary Output #8	56	A-1	OEM Vehicle Interface Connector

Diagnostic tools can verify the configuration of the solenoids with functional identifiers that are noted below.

The “Lockout” solenoid is given a functional identifier of 31.

The “Shift” solenoid is given a functional identifier of 30.

While Eaton recommends the use of Auxiliary Output 5 (W-3) as “Lockout” and the use of Auxiliary Output 7 (Y-3) as “Shift”, any two of the above outputs can be used.

DDEC V

Circuit Name	SID	Pin	Connection
Digital Output	40	V-5	Top 2 3-Way Connector
Digital Output	53	V-6	Top 2 3-Way Connector

DDEC III and IV Schematic Diagram

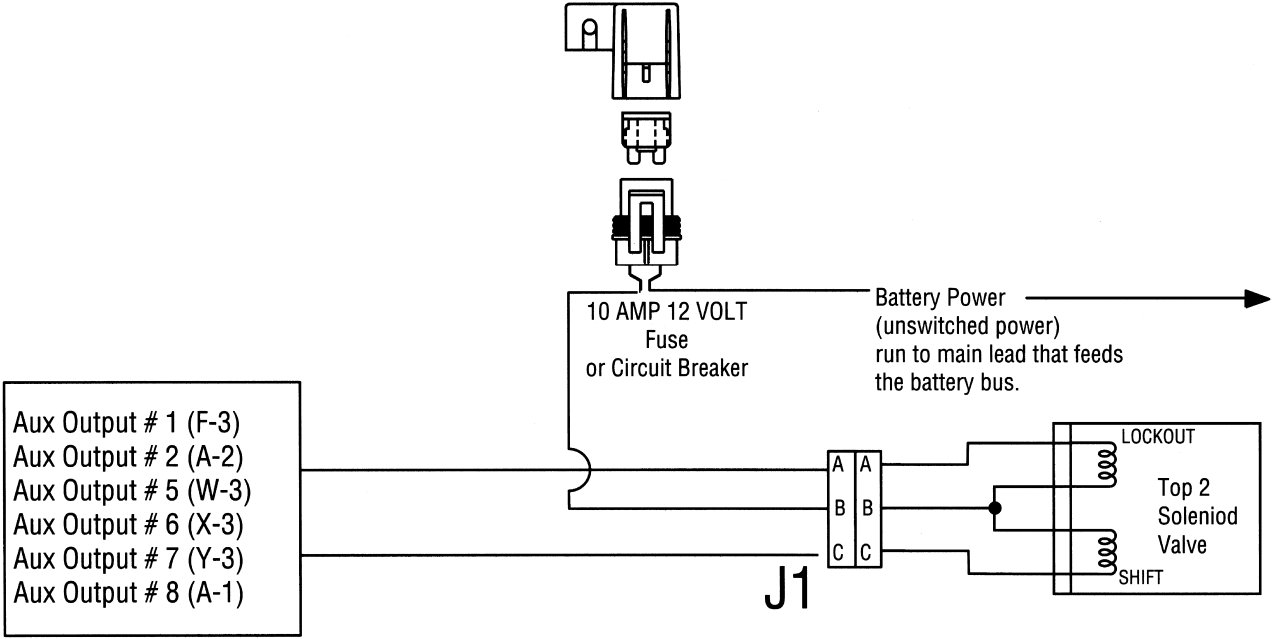

Select two of the available six Auxiliary Outputs for use as “Lockout” and “Shift”.

These two selected pins must be noted and used during the programming of the ECM.

DDEC V Schematic Diagram

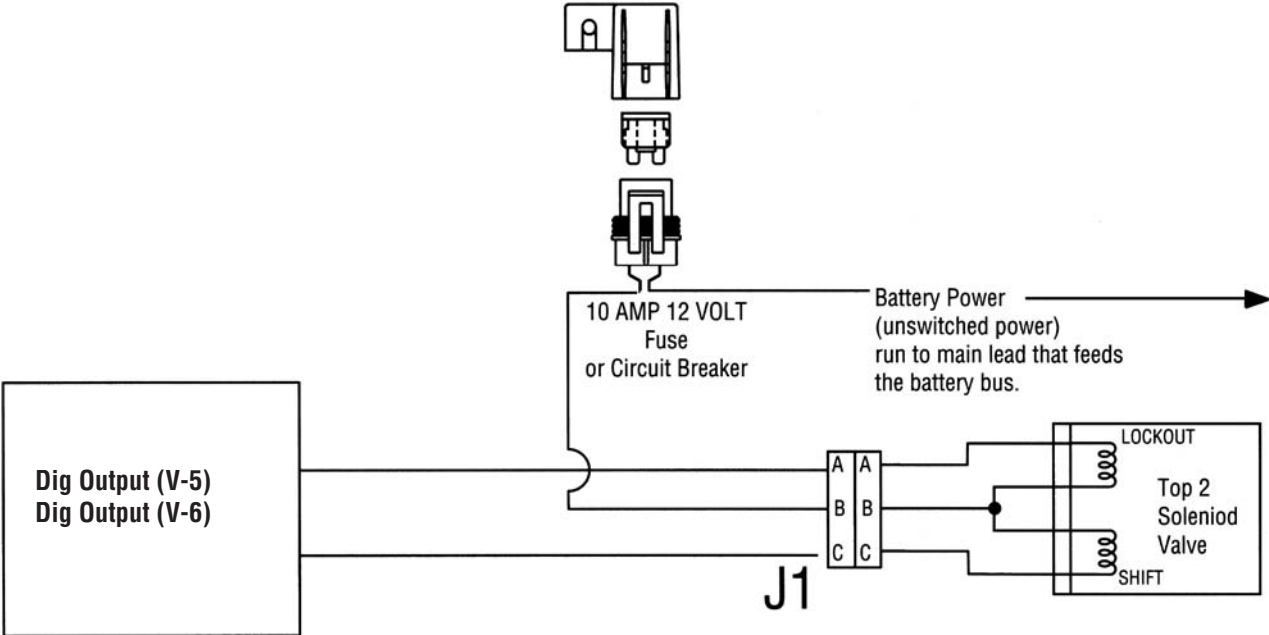

DDEC III, IV and V Wiring Diagram

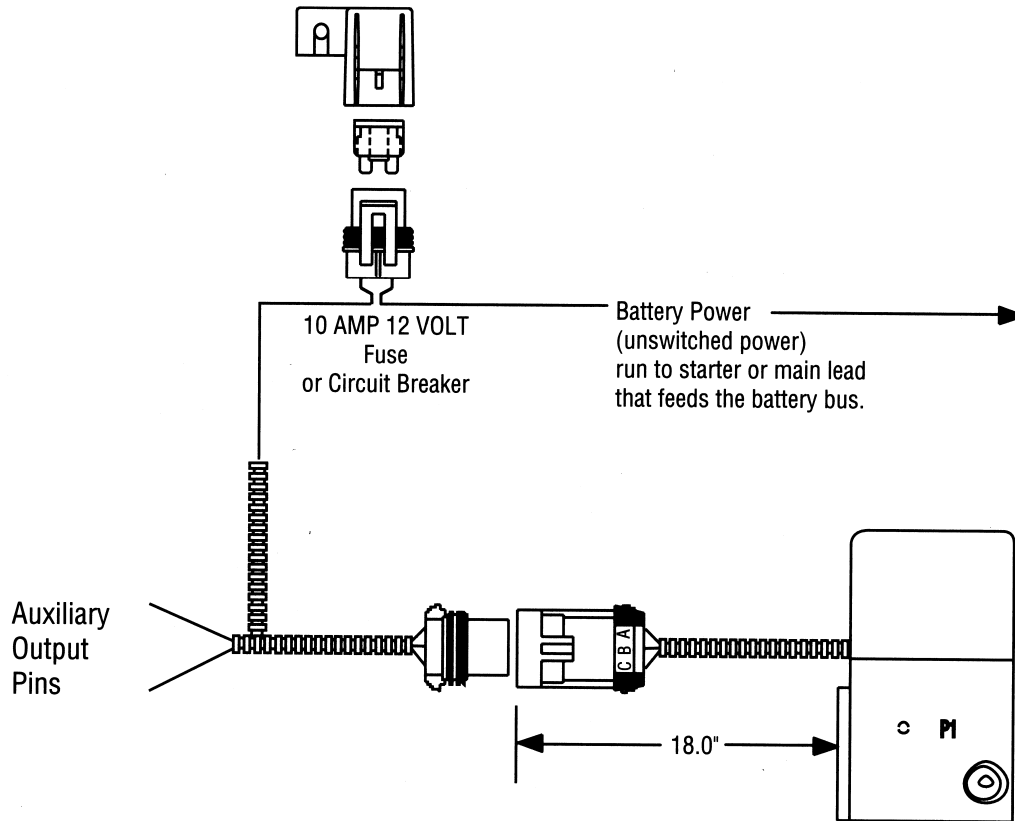

Electrical Requirements

Typical DDEC III and IV System Overview

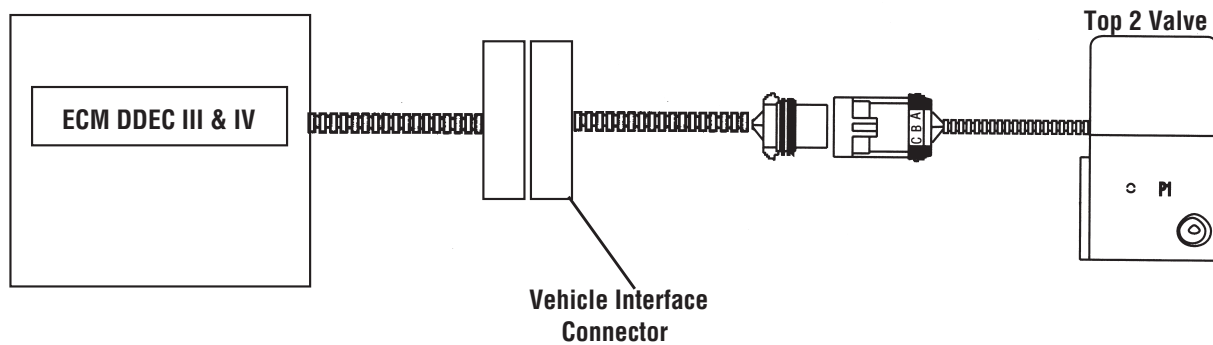

Typical DDEC V System Overview

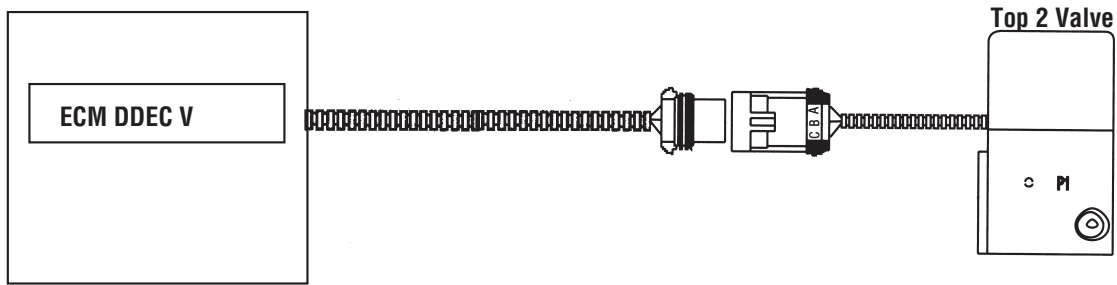

DDEC III and IV ECM Harness Connector

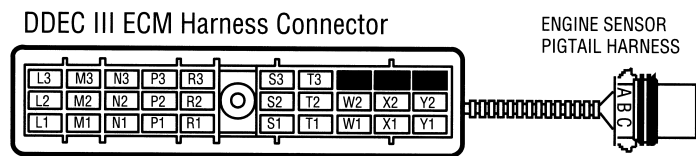

Pins available for selection through engine sensor pigtail harness: W-3, X-3, and Y-3.

Note: Any two of the six pins listed may be used for "Lockout" and "Shift". After deciding which two pins will be used, refer to the End-of-Line Programming information based on your engine type, to complete the programming of the ECM.

DDEC V ECM Harness Connector

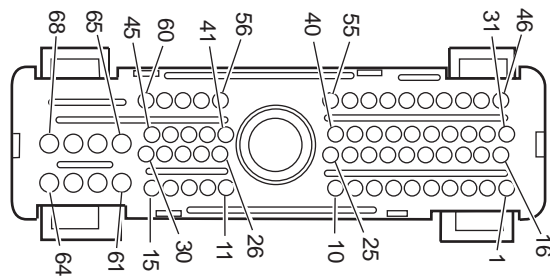

DDEC III and IV OEM Vehicle Interface Connector

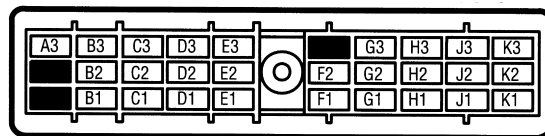

Pins available for selection: A-1, A-2, and F-3.

Line Inspection and Road Test Instructions

Refer to the Line Inspection Form while performing the following procedure:

1. Power Supply Checks:
 - DDEC - Visually verify the power connections at the battery bus through a 10 amp circuit breaker or fuse.
 - Caterpillar - Visually verify the ground connection between the solenoids and truck.
 - Cummins - Visually verify the ground connection between the solenoids and truck.
2. Oil Fill:
 - Verify the transmission has been filled with the correct amount of oil and type before starting engine. Failure to add sufficient oil could damage the transmission. Use Eaton Roadranger CD50 or equivalent as specified in TCMT-0021 the Roadranger Product Lubrication Manual on the www.Roadranger.com Literature Center.
3. End-of-line Programming
 - See page 19, page 21, page 29, or page 31 depending on your engine type.

Dyno / Road Test

4. Verify correct clutch adjustment and correct pedal free travel per clutch manufacturer's requirements.
5. Verify through normal operation that all transmission forward and reverse gears can be obtained. Verify transmission makes automatic shifts in lever position "AUTO".
6. Visually check for oil drips or residue on the transmission and related cooler lines, if used.
7. Make sure that the correct transmission dash label is present and that the driver's instruction booklet is included with the other vehicle information.
8. Verify that a label to alert the customer of type and brand of oil used in the transmission is attached to the transmission or included with other vehicle information.
9. Clear fault codes in the engine ECM. Refer to OEM engine literature.

Line Inspection Form

Inspection Sheet

TOP 2 Line Inspection	<input style="width: 50px; height: 30px;" type="checkbox"/>	<table border="1" style="width: 100%; border-collapse: collapse;"> <tr> <td style="width: 100%;">Oem</td> </tr> <tr> <td>Chassis S/N</td> </tr> <tr> <td>Trans Model # Trans S/N</td> </tr> </table>	Oem	Chassis S/N	Trans Model # Trans S/N																																								
Oem																																													
Chassis S/N																																													
Trans Model # Trans S/N																																													
<table border="1" style="width: 100%; border-collapse: collapse;"> <thead> <tr> <th style="width: 70%;">Description</th> <th style="width: 10%;">Yes</th> <th style="width: 10%;">No</th> <th style="width: 10%;">Corrected</th> </tr> </thead> <tbody> <tr> <td colspan="4">Pre-Start Checks</td> </tr> <tr> <td>1. Power Supply check:</td> <td></td> <td></td> <td></td> </tr> <tr> <td>2. Oil Fill - Eaton® Roadranger®</td> <td></td> <td></td> <td></td> </tr> <tr> <td colspan="4">DYNO/ROAD TEST CHECKS</td> </tr> <tr> <td>4. Correct clutch free travel and adjustment</td> <td></td> <td></td> <td></td> </tr> <tr> <td>5. All forward and reverse gears obtained (Including Automatic Shifting Gears)</td> <td></td> <td></td> <td></td> </tr> <tr> <td>6. Verify no transmission oil leaks</td> <td></td> <td></td> <td></td> </tr> <tr> <td>7. Verify Top 2 shift label Drivers Instructions book in cab</td> <td></td> <td></td> <td></td> </tr> <tr> <td>8. Oil type & brand affixed to vehicle</td> <td></td> <td></td> <td></td> </tr> <tr> <td>9. Clear Fault Codes in Engine ECM</td> <td></td> <td></td> <td></td> </tr> </tbody> </table>		Description	Yes	No	Corrected	Pre-Start Checks				1. Power Supply check:				2. Oil Fill - Eaton® Roadranger®				DYNO/ROAD TEST CHECKS				4. Correct clutch free travel and adjustment				5. All forward and reverse gears obtained (Including Automatic Shifting Gears)				6. Verify no transmission oil leaks				7. Verify Top 2 shift label Drivers Instructions book in cab				8. Oil type & brand affixed to vehicle				9. Clear Fault Codes in Engine ECM			
Description	Yes	No	Corrected																																										
Pre-Start Checks																																													
1. Power Supply check:																																													
2. Oil Fill - Eaton® Roadranger®																																													
DYNO/ROAD TEST CHECKS																																													
4. Correct clutch free travel and adjustment																																													
5. All forward and reverse gears obtained (Including Automatic Shifting Gears)																																													
6. Verify no transmission oil leaks																																													
7. Verify Top 2 shift label Drivers Instructions book in cab																																													
8. Oil type & brand affixed to vehicle																																													
9. Clear Fault Codes in Engine ECM																																													
Comments																																													
Final Inspection Date																																													
Signature																																													
Please send copy to: Eaton Corp. FAX #(269) 383-5520 ATTN: Automation Installations Group or mail copy to : Eaton Corp, 13100 E. Michigan Ave., Galesburg, MI 49053 ATTN: Automation Installations Group																																													

Troubleshooting

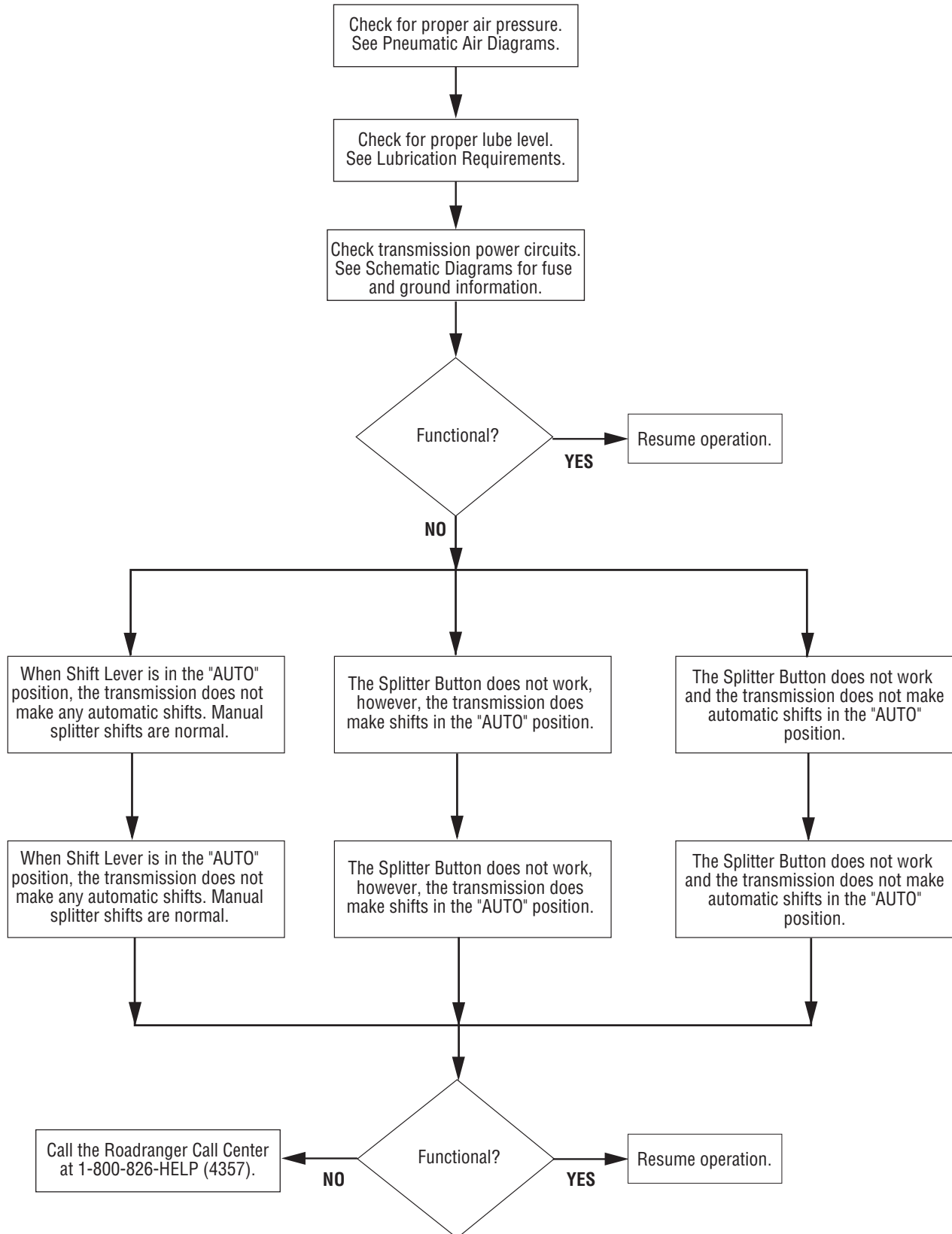

Line Inspection

C15 OEM Diagrams (2004)

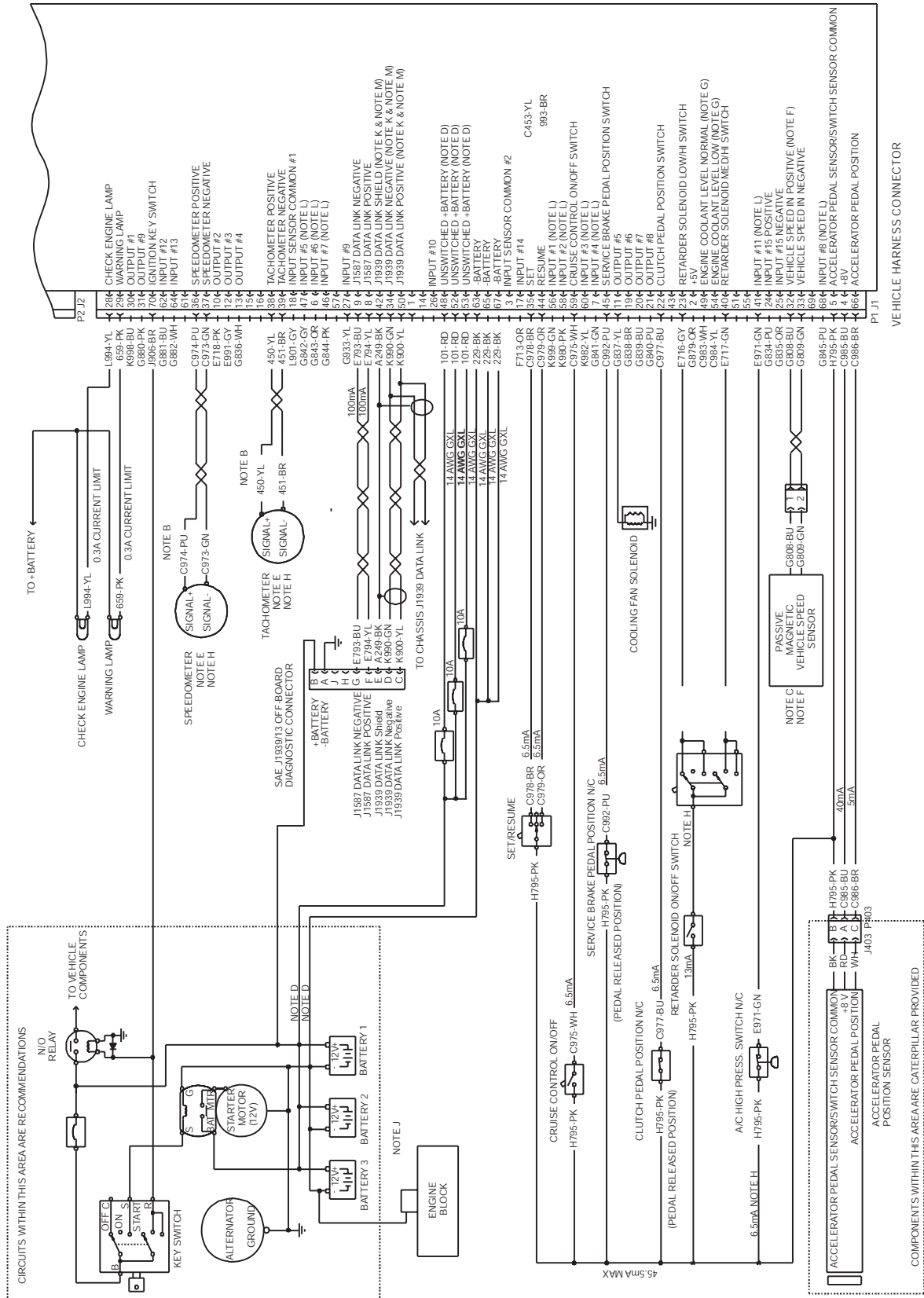

Detroit Diesel

DDEC IV Vehicle Interface Harness

OEM RESPONSIBILITY

SERIES 60 DDEC IV MY2003 EGR VEHICLE INTERFACE HARNESS

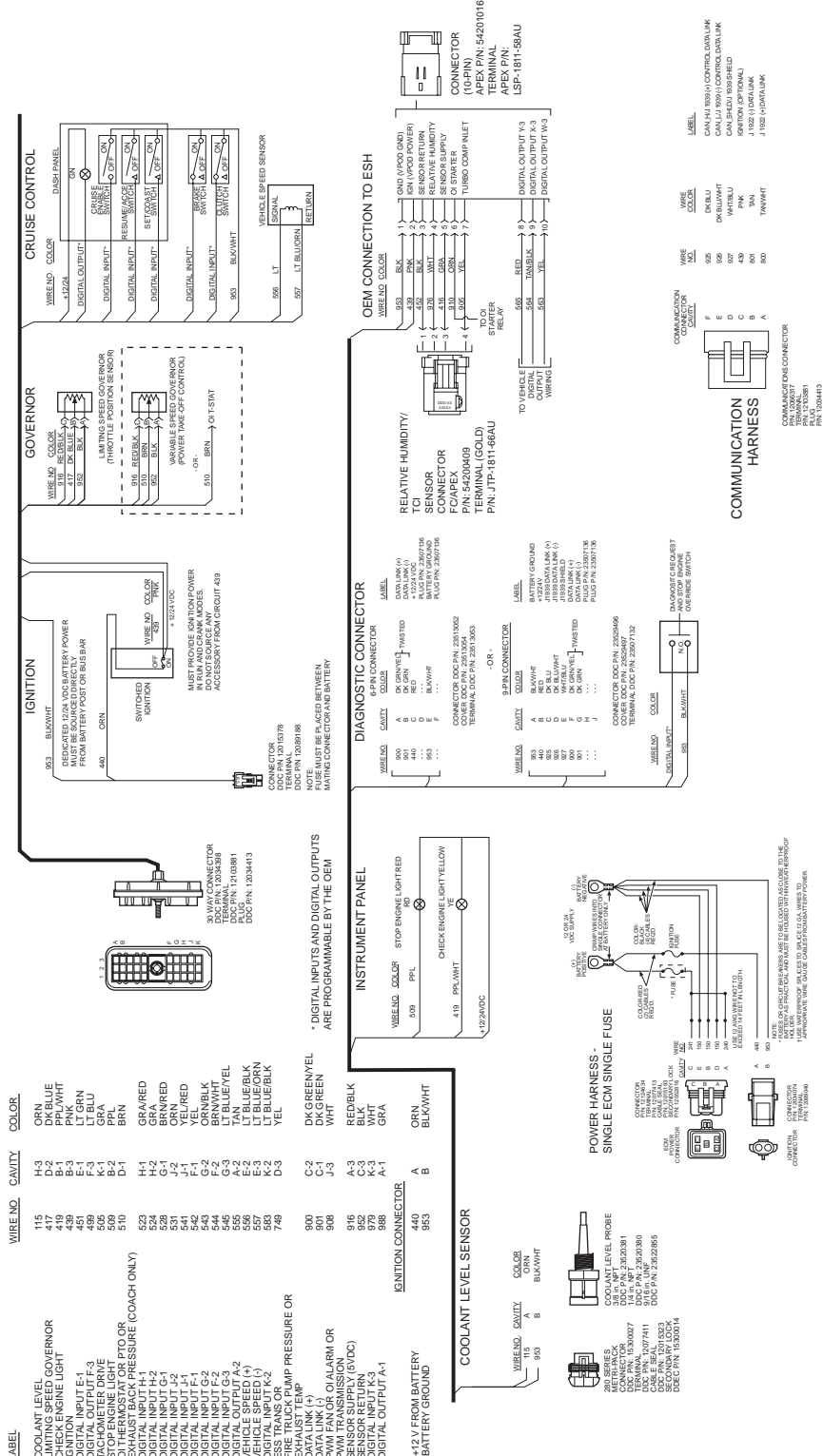

All information subject to change without notice. (Rev. 6/03)
 75A743 0068 Copyright © 2003 DETROIT DIESEL CORPORATION.

DDEC V Vehicle Interface Harness

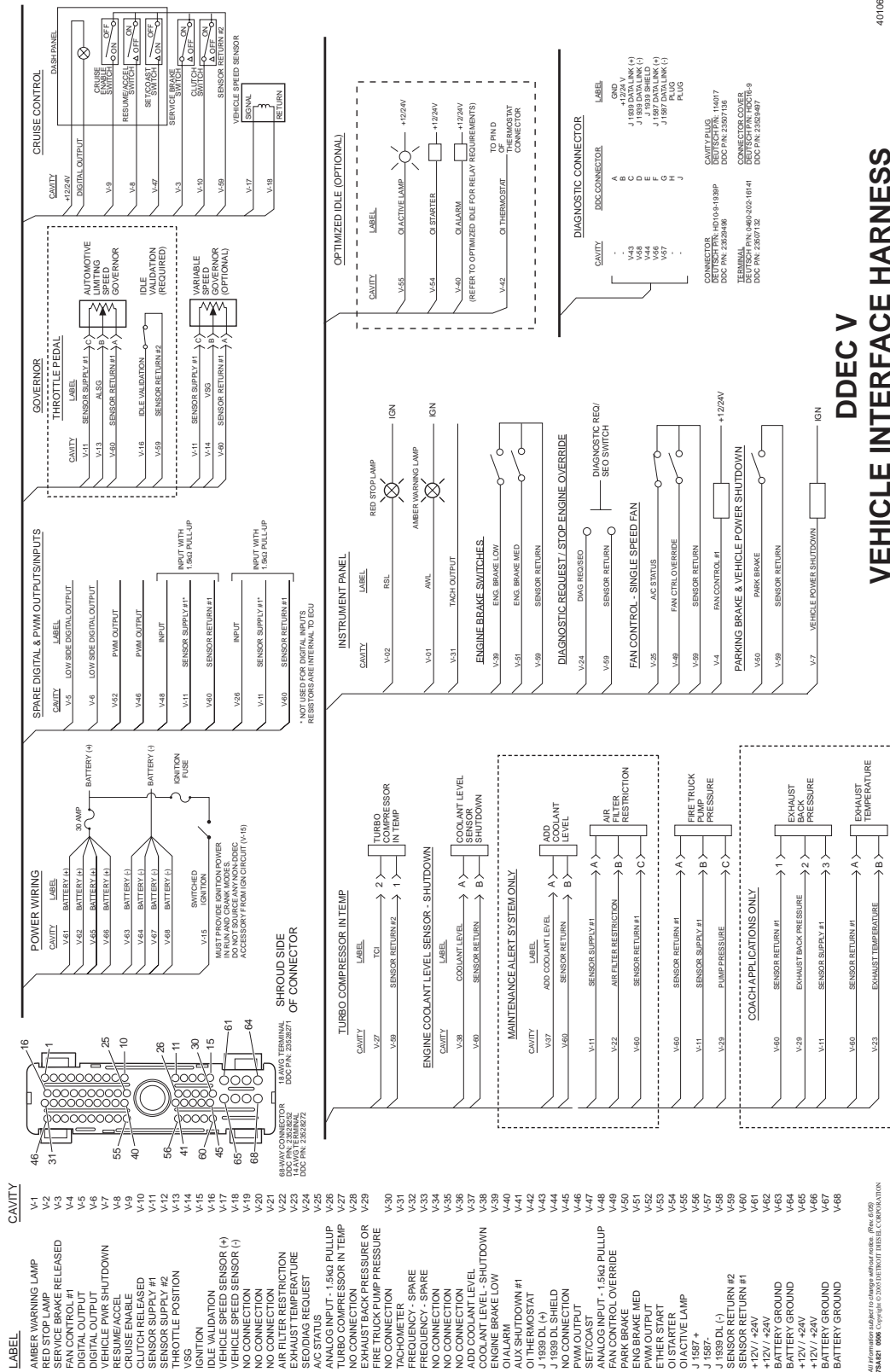

40106

DDEC V VEHICLE INTERFACE HARNESS

Torque Specifications

Part	Torque
Flywheel capscrews	Follow engine manufacturer's specifications
Transmission-to-Engine capscrews	
7/16-14 *	37 - 50 lbs. ft. [50 - 68 N•m]
3/8-16 *	25 - 32 lbs. ft. [34 - 43 N•m]
M10 x 1-3/8 *	26 - 35 lbs. ft. [35 - 47 N•m]
M10 x 1-3/4 *	26 - 35 lbs. ft. [35 - 47 N•m]
Output yoke nut	450 - 500 lbs. ft. [610 - 678 N•m]
PTO mounting capscrews:	
6-bolt opening *	20 - 25 lbs. ft. [27 - 34 N•m]
8-bolt opening *	50 - 65 lbs. ft. [68 - 88 N•m]
Reverse switch (9/16-18)	20 - 25 lbs. ft. [27 - 34 N•m]
Neutral switch/cap (3/4-16)	20 - 25 lbs. ft. [27 - 34 N•m]
Speedometer electronic sensor (3/4-16)	10 - 15 lbs. ft. [14 - 20 N•m]
Lubricant fill plug (1¼-NPT)	60 - 75 lbs. ft. [81 - 101 N•m]
Lubricant drain plug (3/4-NPT)	45 - 55 lbs. ft. [61 - 75 N•m]
Lifting bracket capscrew (3/8-16)	35 - 45 lbs. ft. [47 - 61 N•m]
Rear bearing cover capscrew (3/8-16)	35 - 45 lbs. ft. [47 - 61 N•m]
Transmission nodal mount capscrews (3/4-10)	180 - 190 lbs. ft. [244 - 258 N•m]
Transmission rear support stud nuts (5/8-18)	170 - 185 lbs. ft. [230 - 250 N•m]
Range Air Valve Mounting Screw (#10-24)	21 - 27 lbs. in. [2 - 3 N•m]

* Thread adhesive sealant required.

Suggested Tools

O.E. Tool & Equipment Group/Kent-Moore SPX Corporation 1-800-520-2584

Kent-Moore Part no.	Description
5505027	Volt/Ohm Meter (Standard commercially available VOM)

O.E. Tool & Equipment Group/Kent-Moore SPX Corporation 1-800-328-6657

Kent-Moore Part no.	Description
J-43318	Eaton Test Adapter Kit MD-100

Eaton Service Parts 1-800- 826-HELP (4357)

Part No.	Description
	MD-200

Engine Tools

Contact your local engine representative for the latest tools specifications.

Related Publications

Troubleshooting Guide	TRTS-0070
Service Manuals	TRSM-0550 - RTLO 10-speed Models
	TRSM-0670 - RTLO 13-speed, 18-speed, and Convertible Models
Illustrated Parts Lists	See model specific listing
Driver Instructions	TRDR-0550 - RTLO 10-speed Models
	TRDR-0670 - RTLO 13-speed Models
	TRDR-0800 - RTLO 18-speed Models
	TRDR-3349 - Convertible Models
Lubrication Requirements	TCMT-0020 - Roadranger Products Approved Lubricants
	TCMT-0021 - Roadranger Products Lubrication Manual

For additional information call the Roadranger Call Center at 1-800-826-HELP (4357).

Application Forms

Eaton® Fuller® Transmissions

Form FUL-169



Approved Applications For Fuller Twin Countershaft Mechanical and “Top-2” Transmissions

Written Approval Required For All Applications Not Meeting the Requirements of This Form - Use Form FUL-170 (Request for Application Approval).

All approvals are based on the following conditions:

- Lubricants must meet the requirements published in Eaton TCMT-0021.
- Driveline speed not to exceed 3000 RPM except — RT-6609 -4000 RPM.
- Angular acceleration of driveline is not to exceed 300 rad/s².
- High Angle lubrication kit required when installation angle plus operating grade angle exceeds 12 degrees (20%).
- Vehicle must have sufficient overall reduction to insure Startability (See Startability Attachment — FUL-171).
- PTO torque limit - Maximum combined PTO output torque is not to exceed 500 lbs-ft for Lightning, FR/FRO and Convertible series transmissions. All other transmissions are limited to a maximum of 350 lbs-ft with the standard input shaft bearing (P/N 82504). **IF** the input shaft bearing is upgraded (P/N 4301417), the PTO output torque is not to exceed 500 lbs-ft. The RT-6609 is limited to 300 lbs-ft.
- The maximum allowable torque at the transmission input shaft, due to engine retarding systems and engine friction, must be less than 110% of maximum transmission torque rating.
- Transmission input torque spikes due to drive train resonance, must be less than 300 lbs-ft above the nominal transmission input torque rating for engine speeds above 1000 RPM and vehicle road speed above 20 MPH.
- Vehicle configurations that exceed the 3000 RPM driveline speed can be blanket approved **IF** the engine is electronically programmed to limit the vehicle speed that produces a driveline speed of 3000 RPM or less in top (overdrive) gear.

³ Max Gross H.P.	³ Max. Peak Torque lbs-ft	Transmission Series	^{3,4} GCW limit for Blanket Approval	¹ Maximum Driveline Torque, "A"
250	660	RT-6609-A	74,000 Lbs.	9,700
300	860	RT-8608-L RT-8908-LL RT-8709-B	80,000 Lbs.	12,500
	950	FR-9210B		
370	1050	10XXX	90,000 Lbs.	15,500
	1150	All Other 11XXX RTO-11909-XLL		
	1250	12XXX		
	1350	13XXX		
400	1400	T-14607	140,000 Lbs.	17,500
450	1450	All Other 14XXX		
500	1550	15XXX		
600	1650	16XXX		
	1750	17XXX		
	1850	18XXX		
700	2050	RTLO-20913/18	150,000 Lbs.	17,500
	2250	RTLO-22918		
NOTE 2		2-A-92		9,700
		AT-1202		17,500

NOTE 1 — “A” calculation

A₁ or A₂ must be less than “A”
 A₁ = Peak Engine Torque x
 Lowest Gear Ratio

$$A_2 = \frac{672 \times W}{M \times AR}$$

Where: W =Weight on drive wheels — Lbs.
 M =Tire revolution per mile
 AR =Axle ratio

NOTE 2 — “A” calculation for Auxiliaries

NOTE 3 — Transmission Oil Coolers are:

- Recommended — With engines of 350 H.P. and above.
 Required — With engines 400 H.P. and above, and GCW’s over 90,000 lbs.
 — With engines 400 H.P. and above and 1400 lbs-ft or greater torque
 — With engines 450 H.P. and above
 — With engines 1500 lbs-ft and above

In all cases, cooler must have sufficient capacity to maintain oil temperatures below 250°F at worst case operating conditions.

Additional Application Requirements for Approval of RTLOC-1X909A-T2:

- Application must be for On-Highway⁵ use only.
- For engines certified by Eaton for use with Top 2 transmissions, see Form FUL-200T.
- Vehicle must have a minimum of 0.3% gradeability at cruise speed and 1% gradeability at peak torque. Calculations are to be made at maximum rated conditions.
- Vehicles using Detroit Diesel S60 engines must have rear axle ratio higher than 3.70 and tires with 492 revs/mile or greater.
- Vehicles using Caterpillar C11, C13 or C15 engines must have a rear axle ratio higher than 3.55 and tires with 492 revs/mile or greater.
- Any Progressive Shift engine programming must allow automatic up-shift points to be reached — minimum 1500 RPM.
- Vehicle must have a 12-volt electrical system.
- Vehicle air system must include an air dryer.

⁴ Blanket GCW limit is just a limit for Blanket approved applications. Applications that exceed this limit need to be submitted to Eaton Corporation for approval.

⁵ On-Highway is defined as limited access and general highways. Grades less than 8%, well maintained, concrete or asphalt surface, no more than 10% off-highway operation. Maintained gravel, crushed rock, hard packed dirt or similar road surfaces are acceptable when grades are less than 3%.

Eaton® Fuller®

Application Approval Form FUL-170 – Rev. 01/04

Transmissions

Approval I.D. No.:	Dealer Information
Chassis #(s):	Dealership Name:
No. of Vehicles:	Dealer Address:
Projected Build Date:	Contact:
OEM / Plant Location: /	Telephone: FAX:
Customer/Fleet:	

APPROVAL REQUEST FOR: Transmission Model _____ Oil Cooler: YES NO

ENGINE INFORMATION:

Make: _____ Model: _____ Displacement: _____ Liters
 Rated Horsepower _____ at _____ RPM Peak Torque _____ Lbs-ft at _____ RPM
 Governed Speed: _____ RPM Top Speed Limit Setting _____ MPH Cruise Speed _____ MPH

DRIVELINE INFORMATION:

Rear Axle Make: _____ Model: _____ Ratios: _____ / _____
 Drive Tires Make: _____ Model: _____ Size: _____ or Revs/Mile _____
 Retarder Make: _____ Model: _____ Type: _____ HP
 Clutch Make: _____ Model: _____
 Trans Case Make: _____ Model: _____ Ratios: _____ / _____
 /Aux. Trans

CHASSIS INFORMATION

Model: _____ Drive Configuration (6x4, 4x2) _____ Vehicle Voltage (12 or 24v) 12 V
 Max Weight on Drive Wheels _____ Lbs Max GVW _____ Lbs Max GCW _____ Lbs

VOCATIONAL AND BODY SPECIFIC INFORMATION:

Vocation (Line Haul, Dump, Refuse, Mixer, etc) _____
 Body Type _____ Trailer Type _____ # Trailers _____
 Area of Operation: Country(s) _____ State / Province/Region _____
 Road Usage: Highway _____ % Secondary/City _____ % Off-Highway _____ % Off-Road _____ %
 Maximum Grade on Which Vehicle will be Required to Operate _____ %

TRANSMISSION FEATURE / OPTION REQUIREMENTS: (CHECK BOX OF APPROPRIATE CONFIGURATION)

PTO Usage: None 6 Bolt Engine Split-Shaft Countershaft: 6 Bolt 8 Bolt Aux
 PTO Model: _____ PTO Driven Equipment: _____

PERSON SUBMITTING REQUEST _____ **PHONE:** _____ **FAX:** _____

FIRM NAME & ADDRESS:

THIS APPLICATION IS:		
ADDITIONAL NOTES / REQUIREMENTS:		
SIGNED:	APPLICATION ENGINEER:	DATE:

1. This Application Approval Form (FUL-170) is intended for use as an approval for warranty ONLY. An approval indicates that the given configuration meets the minimum requirements of the specified product; it does not indicate approval to ship the product.
2. All Eaton warranty guidelines apply for coverage and specific labor repair times. Reference Eaton publications TCWY-0600 and TCWY-0900.
3. Refer to form FUL-169 () for Blanket Application Requirements.

Eaton Corporation – TOA
 P.O. Box 4013
 Kalamazoo, MI 49003
 Phone: (269) 342-3000
 Fax: (269) 342-3574
 TransApplications@Eaton.com

Copyright Eaton Corporation, 2012. Eaton hereby grant their customers, vendors, or distributors permission to freely copy, reproduce and/or distribute this document in printed format. It may be copied only in its entirety without any changes or modifications. THIS INFORMATION IS NOT INTENDED FOR SALE OR RESALE, AND THIS NOTICE MUST REMAIN ON ALL COPIES.

Note: Features and specifications listed in this document are subject to change without notice and represent the maximum capabilities of the software and products with all options installed. Although every attempt has been made to ensure the accuracy of information contained within, Eaton makes no representation about the completeness, correctness or accuracy and assumes no responsibility for any errors or omissions. Features and functionality may vary depending on selected options.

For spec'ing or service assistance, call 1-800-826-HELP (4357) or visit our web site at:

www.roadranger.com.
In Mexico, call 001-800-826-4357.