

FS(O)-6406/8406/9406

Type	FS-6406B/ FS B-6406B	FSO-6406A / FSO-8406A	FSBO-6406A / FSBO-8406A	FSBO-9406A
Max. Input Torque [Nm]	950	893/1166	893/1166	1288
Oil Quantity [l]	9.2			
Clutch Housing	SAE 2			
Overall Length [mm]	761			
GVW [t]	18-32			
GCW [t]	33			

General view:

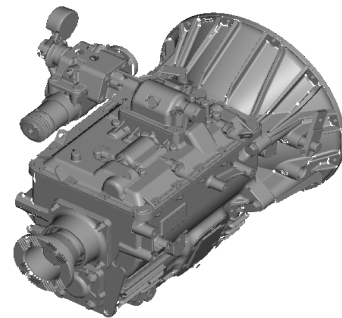
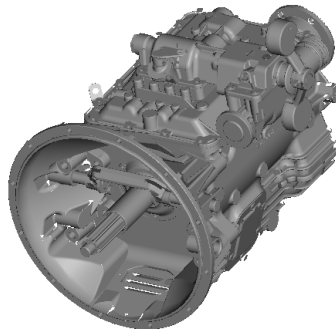
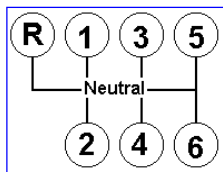

Gear ratios:

GEAR TYPE	1st	2nd	3rd	4th	5th	6th	R	Overall
FS-6406B/ FS B-6406B	8.03	5.06	3.09	1.96	1.31	1.00	7.70	8.03
FSO-6406A / FSO-8406A	7.05	4.13	2.52	1.59	1.00	0.78	6.75	9.04
FSBO-6406A / FSBO-8406A	7.05	4.13	2.52	1.59	1.00	0.78	6.75	9.04
FSBO-9406A	6.38	3.73	2.28	1.43	1.00	0.79	6.11	8.08

FS(O)-6406/8406/9406

Basic dimensions (horizontal version):

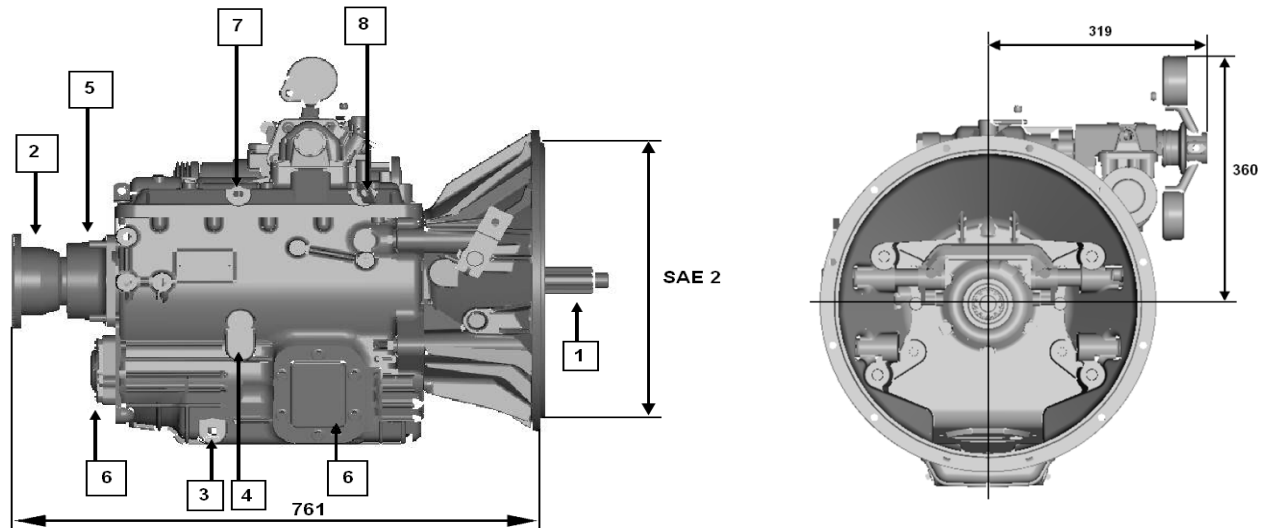

1. Input shaft
2. Output flange
3. Oil drain plug
4. Oil filler & level plug
5. Tachometer sensor
6. PTO opening
7. Reverse light switch
8. Neutral light switch

On a base of agreement with customer gearbox can be additionally fitted with:

- Enhanced shifting quality
 - All forward gears synchronized; low force synchronizers in 1st & 2nd gears (Low Force Boosted Synchronizer)
 - EFM-H friction material on all gears
- High Contact Helical gears
- Flexible vehicle integration
 - Direct, remote or cable control options
 - Both LH / RH PTO SAE2 bolts provision
 - Extended counter shaft PTO
 - Retarder provision
 - PPA unit (for coach application).