

# Eaton® Lubrication TCMT0021 EN-US

October 2017



*Powering Business Worldwide*

BACKED BY  
**Roadranger**  
SUPPORT

**This page intentionally blank**

## Important Eaton Transmission Lubricants Update - January 2017

### Introduction of New Lubrication Specification PS-386

Eaton transmission lubricant specification PS-164rev7 has been replaced by PS-386. All applications that required the use of PS-164rev7 approved lubricants will now require the use of PS-386 approved lubricants.

**OEM Production** - All major OEMs have transitioned to the PS-386 approved lubricants.

**Aftermarket** - Eaton recognized that there was a transition period until PS-164rev7 oils were eliminated in the market. Effective January 1, 2017, warranty coverage requires PS-386. Both PS-164rev7 and PS-386 oils can be mixed. Top-offs using either fluids are permitted.

### Introduction of Procision Transmission Unique Lubricant Specification PS-278

PS-278 approved lubricants are the only acceptable lubricant for the Procision transmission. Do not use PS-278 oil in other Eaton transmission models.

### Introduction of Approved Lubricant Logos

To make identification of approved lubricants easier, new mandatory logos were created. All approved lubricants for PS-386 and PS-278 are required to display the approved lubricant logo on their label.



## General Information

Eaton Lubrication Philosophy	
Benefits .....	1
Unapproved Lubricants - Things to Watch Out For .....	2
Benefits of Using Approved Lubricants .....	2

## Transmission

Application Definitions	
Line Haul (On-Highway) Service .....	3
Vocational Service.....	3
Stationary.....	3
Severe Duty Service .....	3
Transmission Oil Filters.....	4
Operating Temperatures/Cooling Requirements.....	4
Oil Cooler Usage .....	4
Eaton Extended Warranty Protection Plan Lubrication Requirements.....	4
Transmission Lubrication Procedures	
Transmission Oil Level Check .....	5
Drain Transmission Oil.....	5
Drain Transmission Oil Cooler, if equipped .....	5
Fill Transmission Oil.....	6
Fill Transmission Oil Cooler, if equipped .....	6
Transmission Lubricant Capacities	
Heavy-Duty Transmission Lubricant Capacities .....	6
Medium-Duty Transmission Lubricant Capacities .....	9
Eaton Transmission Lubricant and Drain Interval Lists	
NAFTA .....	10
Europe .....	11
Australia.....	12
Asia Pacific .....	13
India .....	14
Africa and Middle East .....	15

## Hydraulic Launch Assist

Eaton Hydraulic Launch Assist Lubrication Requirements	
Lubricant Drain Interval List .....	17

## Clutch

Eaton Clutch Lubrication Requirements	
Release Bearing Failure .....	19
Grease Contaminated with Debris.....	19
Debris Close-Up .....	19
Grease Information	
What To Look For When Selecting Grease.....	20
Grade (Consistency) .....	20
Thickener Type (Compatibility) .....	20
Performance.....	21
Clutch Lubrication Procedure .....	22
Eaton Clutch Lubrication and Service Interval List.....	23

## Eaton Lubrication Philosophy

In promoting component reliability and longevity, proper lubrication is the key to a sound and effective maintenance program. Without effective lubricants at proper levels and temperatures, remaining maintenance procedures will not keep components functional.

Synthetic lubricants have proven to be superior to petroleum products and represent opportunities to promote superior maintenance and bottom line operating performance while significantly extending component service life and reliability. Certain products and applications, as noted in this manual, require the use of approved synthetic lubricants.

A list of approved lubricants and suppliers can be found at [Roadranger.com](http://Roadranger.com) in the approved Lubricant Supplier Manual, TCMT0020.

It is important to perform a daily pre-trip inspection of drivetrain components for lubricant leaks. Leaks should be brought to the attention of maintenance and immediate corrective action should be taken.

### Benefits

Extended Drain synthetic lubricants offer superior thermal and oxidative stability for extended product performance and reliability. The superior performance characteristics of these lubricants enable component manufacturers to offer extended drain intervals and extended warranties. Added benefits include a more efficient drivetrain that translates into proven fuel economy savings over mineral based lubricants.

Extended Drain synthetic lubricants are advantageous in all applications and Eaton highly recommends for severe duty applications and in cold climates.

It is important to use the lubricants that are approved for the current specifications set forth by each component manufacturer. Look for the appropriate approval code on the container.

Use of lubricants meeting these specifications will ensure the highest performing lubricants for maximum performance.

To identify approved lubricants - look for the 'Eaton Approved Lubricant' label on the container.



**Note:** Eaton Approved Lubricant Logos mandatory use in 2015.

**Note:** Eaton discontinued the use of the E500 logo in 2006.

**Note:** Eaton and Dana Genuine Lubricants logo was discontinued in 2012.

## Unapproved Lubricants - Things to Watch Out For

Unfortunately, the product labeling can be difficult to understand. Eaton recommends using only lubricants with the 'Eaton Approved Lubricant' label. Here is some common jargon to look for when determining if a lubricant is approved.

Jargon to avoid:

- Product X **meets and/or exceeds** the manufacturer's requirements of ...
- Product X is **recommended for use** where ...

What to look for:

- **Approved for/by ...**

## Benefits of Using Approved Lubricants

Lubricants must meet rigorous test criteria set by the component manufacturer to ensure performance and long life. Approved lubricants are designed to work with the specific component. When improper or unapproved lubricant is used, several problems can occur.

Benefits of using approved lubricants:

- Oil formulation is tested per component manufacturer's specifications
- Reduced wear on components such as gears and bearings
- Longer life by reducing operating temperatures
- Prevention of corrosion, especially when copper coolers are used
- Excellent cold temperature performance
- Maintain extended warranty coverage

Risks from not using approved lubricants are:

- Shortened bearing life
- Seal leakage
- Reduced fuel economy
- Shortened copper cooler life
- Loss of warranty coverage



**Bearing Failure**

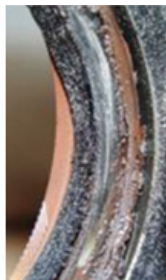

**Seal Coking**



**Transmission Sludge**



**Copper Cooler Failure**

## Application Definitions

### Line Haul (On-Highway) Service

- Line Haul is moving different types of freight in high mileage operation (over 50,000 miles (80,000 km) per year).
- Operation on road surfaces of good to excellent concrete or asphalt.
- 80% of distances are more than 30 miles (48 km) between starting and stopping, with remaining 20% within 30 miles between starting and stopping.
- Typical vehicle configurations are 4 x 2, 6 x 2, and 6 x 4 tractor/trailer combinations some straight trucks. Typical Vehicle Uses:
  - Line Haul
  - Recreational
  - Rescue
  - Fire Service
  - Transit Coach

Check fluid levels and inspect for leaks at regular PM maintenance intervals, not to exceed 12,000 miles.

### Vocational Service

- Low mileage operation (under 60,000 miles (96,500 km) per year).
- Off-highway or areas of unstable or loose unimproved road surfaces.
- Less than 30 miles (48 km) between starting and stopping.
- Typical Vehicle Uses:
  - City Delivery
  - Construction
  - Heavy Haul
  - Logging
  - Mining
  - Oil Field
  - Refuse
  - School Bus
  - Intercity Bus/Coach
  - Agriculture
  - Yard Tractor

Check fluid levels and inspect for leaks every 50 hours.

### Stationary

- Transmissions not used for mobile applications.
- Check fluid levels and inspect for leaks every 50 hours.

### Severe Duty Service

- Consistent operation at or near maximum GCW or GVW ratings.
- Dirty or wet environments.
- Consistent operation on grades greater than 8%.

## Transmission Oil Filters

Transmission oil filters are required for all 2050 lb-ft and 2250 lb-ft rated transmission models, and for all Procision™ models. Transmission filters should be changed during regular transmission lube change intervals. Inspect the transmission filter for damage or corrosion during all preventative maintenance checks. Replace as necessary.

## Operating Temperatures/Cooling Requirements

Transmissions must not be operated at temperatures above 250 °F (121 °C). Operation at temperatures above 250 °F (121 °C) causes loaded gear teeth temperatures to exceed 350 °F (177 °C) which will ultimately lead to premature gear failure. If the elevated temperature is associated with an unusual operating condition that will recur, a transmission oil cooler must be added, or the capacity of an existing cooling system increased.

The following conditions, in any combination, can cause operating temperatures of over 250 °F (120 °C):

- Operating consistently at high/low speeds
- High ambient temperatures
- High horsepower operation
- Restricted airflow around transmission
- Excessive use of engine retarder
- Exhaust system proximity to transmission
- High power PTO operation for extensive periods while stationary
- High engine RPM for extensive periods

External oil coolers are available to reduce operating temperatures when the above conditions are encountered.

Eaton oil cooler systems must meet a minimum requirement of 3/4" water coolant lines and 8 GPM water coolant flow at 1500 RPM. **The end user is ultimately responsible for maintaining transmission lube temperatures below 250 °F (121 °C).** Transmission oil coolers must be used to reduce operating temperatures when the above conditions are encountered.

## Oil Cooler Usage

Transmission oil coolers are recommended for:

- Engines 350 hp and above

Transmission oil coolers are required for:

- Engines 400 hp and above and 1,400 lb-ft (1498 Nm) or greater torque
- Engines 400 hp and above and a GVW/GCW over 90,000 lbs
- Engines 450 hp and above
- Engines 1500 lb-ft (2033 Nm) and above
- All Procision™ models (See TRIG0990 for more details.)

## Eaton Extended Warranty Protection Plan Lubrication Requirements

- Approved extended drain lubricants are required to maintain Roadranger® Extended Warranty Protection Plans.
- For specific details about Eaton extended warranty programs, refer to the Roadranger® Warranty Guide, TCWY0900, or call 1- 800-826-HELP (4357).
- For a complete list of approved lubricants, see Roadranger.com, Lubricants - TCMT0020.



## Transmission Lubrication Procedures

Each Transmission model has specific lubrication requirements. Consult the appropriate Transmission Service Manual for detailed instructions.

### Transmission Oil Level Check

**Note:** Before checking the oil level, the engine must be idling and the transmission in neutral for at least 2 minutes. Lubricant temperature must be between 60 °F and 120 °F (15.5 °C and 48.8 °C).

Inspect the transmission exterior for leaks. Look around the oil filter and exterior seals for damage and replace as necessary.

Check fluid levels and inspect for leaks at regular intervals, not to exceed 12,000 miles.

The lubricant level can be checked by the fill hole or the sight glass. They are usually located on the driver's side of the transmission.

1. Turn engine off.
2. Remove fill hole plug (or view oil level through the sight glass).
3. Lubricant must be level with the hole.

**Note:** For transmissions with dipsticks, the proper level is between the cold ADD mark and the cold FULL mark.

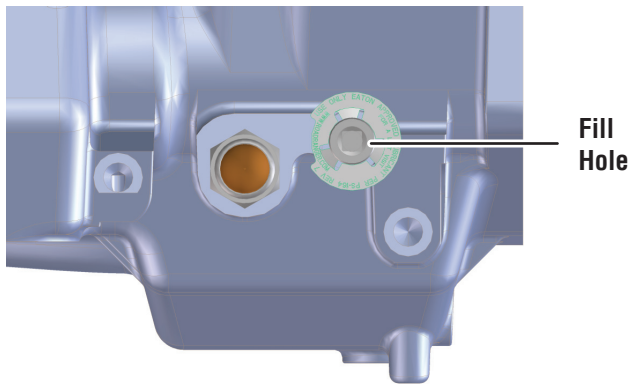
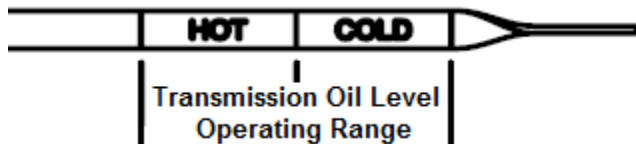

✓ Proper Oil Level with Sight Glass

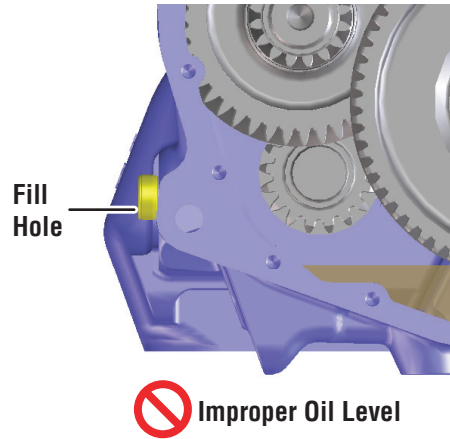
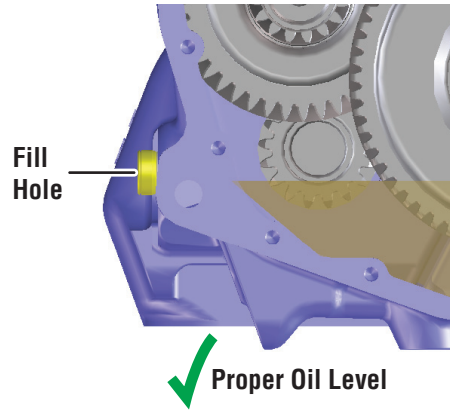

### Drain Transmission Oil

1. Use a drain pan under the transmission drain plug to collect oil from the bottom of the transmission.
2. Make sure the oil temperature is cool.
3. Clean around drain plug and remove plug.
4. Allow transmission oil to drain out.
5. Clean drain plug and torque as required.

### Drain Transmission Oil Cooler, if equipped

1. Remove both cooler lines at the transmission.
2. Pressurize one line with 30 PSI [0.2 MPa] of air pressure to force the oil out.
3. Capture the oil in a oil drain pan from the other hose.
4. Reconnect the coolant lines to the transmission, making sure lines are not crossed.

## Fill Transmission Oil

1. Remove transmission oil fill plug.
2. Make sure drain plug is properly installed.
3. Fill with approved oil until the oil starts flowing out the fill hole.
4. Clean, install, and properly and torque fill plug.

## Fill Transmission Oil Cooler, if equipped

1. After filling the transmission with oil, place the vehicle in Neutral and start the engine.
2. Allow the input shaft of the transmission to rotate by releasing the clutch pedal. The oil pump will fill the cooler.
3. After one minute, shut off the engine, recheck the transmission oil level, and top off lubricant. Repeat this process until proper lubricant level is achieved.

## Transmission Lubricant Capacities

**Note:** Capacity of transmissions equipped with PTOs or Oil Coolers are greater than capacities listed. These values are approximate. Always use the fill hole as final reference.

## Heavy-Duty Transmission Lubricant Capacities

Capacities are sorted by model number only. The prefixes are included when necessary.

The Heavy-Duty (HD) chart includes the following prefixes: AT, FR, FRO, FRLO, RT, RTAO, RTL, RTLO, RTLOM, RTO, RTOM, RTOO, RTX, T, TO and TX.

HD Model Number	Pints (US)	Liters
1056AA	29	14
10710 (-AC, -AS, -AS2)	26	12
10910 (-AS3, -DM2, -DM3)	26	12
1110	25	12
11109 (-AT)	88	42
11210	23.5	11
11509	25	12
1157DL	27	13
1157DLL	29	14
11605	22	10
11606	26	12
11607 (-ASX)	36	17

HD Model Number	Pints (US)	Liters
11607L	28	13
11607LL	31	15
11608	26	12
11608LL	29	14
11609	27	13
11610	26	12
RTLO-11610	28	13
11610 (-T2)	31	15
11613	29	14
11615	28	13
11707 (DLL, LL)	28	13
11708LL	28	13
11709	27	13
11709ALL	28	13
11710	26	12
RTL-11710 (T2)	28	13
11710 (-AS)	89	42
11715	28	13
11813	29	14
11908LL	28	13
11909ALL	28	13
1202	11	5
12210	23.5	11
12509	25	12
12510	25	12
12513	27	13
12515	28	13
12508LL	28	13
12609	27	13
12610	28	13
12613	29	14
12709	27	13
12709ALL	28	13
12710 (-AC, -AS, -AS2)	26	12
RTL-12710	28	13
12713	28	13

# Transmission

HD Model Number	Pints (US)	Liters
12813	29	14
12909ALL	28	13
12910 (-AS3, -DM2, -DM3)	28	13
12913	28	13
13109 (-AT)	88	42
13210	23.5	11
13609	27	13
13610	28	13
13613	29	14
13707 (DLL, MLL)	28	13
13709	27	13
13709ALL	28	13
13710	26	12
RTL-13710	28	13
13710 (-AS)	89	42
13813	29	14
13909ALL	28	13
14109 (-AT) (Ceemat)	88	42
14210	23.5	11
14607 (-ASX)	36	17
14608	28	13
14608LL	29	14
14609	27	13
14610	28	13
14613	29	14
RTLO-14613	28	13
14615	30	14
14618	28	13
14708LL	29	14
14709	27	13
14709ALL	28	13
14710 (-AC, -AS, -AS2)	26	12
RTL-14710	28	13
14710-AS (CEEMAT®)	89	42
14713	28	13
14713 (-T2)	27	13

HD Model Number	Pints (US)	Liters
14715	28	13
14718	28	13
14718 (-T2)	27	13
14813	29	14
14908LL	28	13
14909ALL	28	13
14910 (-AS3, -DM2, -DM3)	28	13
14913	28	13
14915	28	13
14918 (-A2, -AS3)	28	13
15210	23.5	11
15610	28	13
15613	29	14
15615	30	14
15618	28	13
15709	27	13
15710	26	12
15715	28	13
15813	29	14
15909ALL	28	13
16210	23.5	11
16610	28	13
16618	28	13
16709	27	13
16710 (-AC, -AS, -AS2)	26	12
16710-AS (CEEMAT®)	89	42
16713	28	13
16713 (-T2)	27	13
16718	28	13
16718 (-T2)	27	13
16908LL	28	13
16909ALL	28	13
16910 (-AS3, -DM2, -DM3)	28	13
16913	28	13
16913L (-DM3)	28	13
16915	28	13

# Transmission

HD Model Number	Pints (US)	Liters
16918 (-AS2, -AS3)	28	13
17210	23.5	11
17610	28	13
18210	23.5	11
18610	28	13
18710 (-AS)	26	12
18718	28	13
18910 (-AS2, -AS3)	26	12
18913 (-T2)	28	13
18918 (-AS2, -T2, -AS3)	28	13
2-A-92	12	6
20913	28	13
20918 (-AS2, -AS3)	28	13
22918 (-AS2, -AS3)	28	13
610	12	6
613	16	8
6609	12	6
6610	12	6
6613	16	8
7608LL	19.5	9
8607	36	17
8608L	27	13
8609	12	6
8709	26	12
8908LL	28	13
905	22	10
906	26	12
909	25	12
910	25	12
913	27	13
915	28	13
9508	25	12
9509	25	12
9513	27	13
955AL	28	13
955ALL	25	12

HD Model Number	Pints (US)	Liters
958LL	28	13
9710	26	12

<b>Endurant™</b>		
EEO-1XF112C	16	7.5

<b>HD Automated UltraShift® PLUS (use of the following suffixes)</b>		
LAS (Linehaul)	26	12
VAS/VCS/VHP/VMS/VXP (Vocational)	28	13

<b>Fuller Advantage® Series</b>		
Automated: FAOM-1X810S-EC3	16	7.5
Manual: FAO(F) / FAOM (F)-1X810C	16	7.5

## Medium-Duty Transmission Lubricant Capacities

The Medium-Duty (MD) model numbers include the following prefixes: FS, FSO, ES, ESO

MD Model Number	Pints (US)	Liters
4005	10.5	5
4106	14	6.5
4205	12.5	6
5005	10.5	5
5106	18	9
5205	12.5	6
5206	14	6.5
5306	18	9
5406	19.5	9
6005	19	9
6105	19	9
6106	19	9
6205	19	9
6206	18	9
6305	19.5	9
6306	19.5	9
6406	19.5	9
7206	20	9
8206	20	9
8406	19.5	9
10309	24	11.5
11109	18	8.5
11209	18	8.5
12109	18	8.5
12209	18	8.5
15409	24	11.5
20409	24	11.5

The Medium-Duty (MD) Automated model numbers including the following prefixes: F and FO.

MD Automated UltraShift® PLUS Model Number	Pints (US)	Liters
5405B-DM3	21	10
5406B-DM3	21	10
5505B-DM3	21	10
5506B-DM3	21	10
6405B-DM3	21	10
6406B-DM3	21	10
6505B-DM3	21	10
6506B-DM3	21	10

MD Hybrid Model Number	Pints (US)	Liters
All Models	19.5	9

MD Precision Model Number	Pints (US)	Liters
EDCO	25	12

## Eaton Transmission Lubricant and Drain Interval Lists

### NAFTA

For a list of approved Extended Service Interval Lubricant Suppliers, visit [www.Roadranger.com/Lubricants](http://www.Roadranger.com/Lubricants) to download TCMT0020.

Product	Transmission Torque	Service Interval	Lubricant Specification	SAE Viscosity Grade	Drain Interval		
					Line Haul	Vocational/Bus	Stationary
Hybrid (see Note 1)	All	Extended	PS-386	N/A	500,000 mi (800,000 km) or 10 years	180,000 mi (288,000 km) or 3 years	2,000 hours or 5 years
Endurant™	All	Extended	PS-386	N/A	750,000 mi (1,200,000 km) or 5 years	N/A	N/A
Automated Heavy-Duty (UltraShift® PLUS) (Fuller Advantage®) (see Note 1)	All	Extended	PS-386	N/A	500,000 mi (800,000 km) or 5 years	180,000 mi (288,000 km) or 3 years	2,000 hours or 5 years
Automated Medium-Duty (UltraShift® PLUS) (see Note 1)	All	Extended	PS-386	N/A	500,000 mi (800,000 km) or 10 years	180,000 mi (288,000 km) or 3 years	2,000 hours or 5 years
Manual Transmission (Fuller Advantage®) (FRW Models)	All	Extended	PS-386	N/A	500,000 mi (800,000 km) or 5 years	180,000 mi (288,000 km) or 3 years	2,000 hours or 5 years
Manual Transmission Heavy-Duty (see Note 1)	Above 1,850 lb-ft (2,500 Nm)	Extended	PS-386	N/A	500,000 mi (800,000 km) or 5 years	180,000 mi (288,000 km) or 3 years	2,000 hours or 5 years
		Standard	PS-321	N/A	75,000 mi (120,000 km) or 1 year	75,000 mi (120,000 km) or 1 year	500 hours or 1 year
	Heavy Duty Diesel Engine Oil (MIL-PRF-2104H)		SAE 50	60,000 mi (96,500 km) or 1 year	60,000 mi (96,500 km) or 1 year	500 hours or 1 year	
	CAT TO-4	SAE 40 SAE 50					
Manual Transmission Medium-Duty (see Note 1)	All	Extended	PS-386	N/A	500,000 mi (800,000 km) or 10 years	180,000 mi (288,000 km) or 3 years	2,000 hours or 5 years
		Standard	PS-321	N/A	75,000 mi (120,000 km) or 1 year	75,000 mi (120,000 km) or 1 year	500 hours or 1 year
	Heavy Duty Diesel Engine Oil (MIL-PRF-2104H)		SAE 50	60,000 mi (96,500 km) or 1 year	60,000 mi (96,500 km) or 1 year	500 hours or 1 year	
	CAT TO-4	SAE 40 SAE 50					
ASW Clutch Module	All	Standard	Dexron VI	N/A	150,000 mi (250,000 km) or 3 years	150,000 mi (250,000 km) or 3 years	N/A
Procision (see Note 1)	All	Extended	PS-278	N/A	150,000 mi or 10 years	150,000 mi or 10 years	N/A

**Note:** 1. Transmissions with Extended Warranties or Extended Protection Plans require the Extended Service Interval lubricant to maintain warranty agreements.

## Europe

For a list of approved Extended Service Interval Lubricant Suppliers, visit [www.Roadranger.com/Lubricants](http://www.Roadranger.com/Lubricants) to download TCMT0020.

Product	Transmission Torque	Service Interval	Lubricant Specification	SAE Viscosity Grade	Drain Interval		
					Line Haul	Vocational/ Bus	Stationary
Hybrid	All	Extended	Eaton PS-386	N/A	800,000 Km	300,000 Km or 3 years	N/A
Automated (UltraShift® PLUS)	All	Extended	Eaton PS-386	N/A	800,000 Km	300,000 Km or 3 years	2,000 hours or 5 years
Manual Transmission	< 1,850 lb-ft < 2,500 N•m	Extended	Eaton PS-386	N/A	800,000 Km	300,000 Km or 1 year	2,000 hours or 5 years
			Eaton PS-321	N/A	120,000 Km	120,000 Km or 3 years	600 hours or 1 year
			MTF Gear Oil API GL-4	SAE 80W90 SAE 75W90	100,000 Km (See Note 1)	100,000 Km or 1 year (See Note 1)	500 hours or 1 year (See Note 2)
			Engine Oil API-CD	SAE 50 SAE 40 SAE 30			
			MIL-2104H				
CAT TO-4							
Manual Transmission	> 1,850 lb-ft > 2,500 N•m	Extended	Eaton PS-386	N/A	800,000 Km	300,000 Km or 3 years	2,000 hours or 5 years

**Note:** Standard service interval lubricants require an initial drain prior to regular drain intervals:

1. First oil drain between 5,000-10,000 Km prior to regular drain intervals on all models except: FS(O)4106, FS(O)5206, ES11X09, ES012X09, FS(O)10309, ES(O)1X409, ES020409.
2. First oil drain at 40 hours or 2 months prior to regular drain intervals on all models except: FS(O)4106, FS(O)5206, ES11X09, ES012X09, FS(O)10309, ES(O)1X409, ES020409.

## Australia

For a list of approved Extended Service Interval Lubricant Suppliers, visit [www.Roadranger.com/Lubricants](http://www.Roadranger.com/Lubricants) to download TCMT0020.

Product	Transmission Torque	Service Interval	Lubricant Specification	SAE Viscosity Grade	Drain Interval
Hybrid	All	Extended	Eaton PS-386	N/A	400,000 Km
Automated (UltraShift® PLUS)	All	Extended	Eaton PS-386	N/A	400,000 Km
Manual Transmission	< 1,850 lb-ft < 2,500 N•m	Extended	Eaton PS-386	N/A	400,000 Km
		Standard	Eaton PS-321	N/A	120,000 Km
			MTF Gear Oil API GL-4	SAE 80W90 SAE 75W90	100,000 Km
			Engine Oil API-CD	SAE 50 SAE 40 SAE 30	
			MIL-2104H		
CAT TO-4					
Manual Transmission	> 1,850 lb-ft > 2,500 N•m	Extended	Eaton PS-386	N/A	400,000 Km

**Note:** Oil analysis is required to determine exact oil change interval which can vary depending on the application.

**Note:** Oil Changes should be taken from the center of the transmission with oil at operating temperature using a suitable syringe.

**Note:** Oil sampling to take place at 80,000 to 100,000 Km.

**Note:** DO NOT USE ADDITIVES OR FRICTION MODIFIERS.



## Asia Pacific

For a list of approved Extended Service Interval Lubricant Suppliers, visit [www.Roadranger.com/Lubricants](http://www.Roadranger.com/Lubricants) to download TCMT0020.

Product	GCW	Cooler Used	Service Interval	Lubricant Spec.	SAE Viscosity Grade	Drain Interval		
						Line Haul	Vocational / Bus	Stationary
Hybrid	All	No	Extended	Eaton PS-386	N/A	800,000 Km	300,000 Km or 3 years	N/A
Automated (UltraShift® PLUS)	All	Yes / No	Extended	Eaton PS-386	N/A	800,000 Km	300,000 Km or 3 years	2,000 hours or 5 years
Manual Transmission	< 50 Ton	Yes / No	Extended	Eaton PS-386	N/A	800,000 Km	300,000 Km or 3 years	2,000 hours or 5 years
			Standard	Eaton PS-321	N/A	120,000 Km	120,000 Km or 1 year	600 hours or 1 year
				MTF Gear Oil API GL-4	SAE 80W90 SAE 75W90	100,000 Km	100,000 Km or 1 year	500 hours or 1 year
				Engine Oil API-CD	SAE 50 SAE 40 SAE 30			
				MIL-2104H				
				CAT TO-4				
Manual Transmission	> 50 Ton	Yes	Extended	Eaton PS-386	N/A	800,000 Km	300,000 Km or 3 years	2,000 hours or 5 years
Manual Transmission	> 50 Ton	Yes	Standard	Eaton PS-321	N/A	120,000 Km	120,000 Km or 1 year	600 hours or 1 year
				MTF Gear Oil API GL-4	SAE 80W90 SAE 75W90	100,000 Km	100,000 Km or 1 year	500 hours or 1 year
				Engine Oil API-CD	SAE 50 SAE 40 SAE 30			
				MIL-2104H				
				CAT TO-4				
				Extended	Eaton PS-386	N/A	400,000 Km	150,000 Km or 2 year
			Standard	Eaton PS-321	N/A	60,000 Km	60,000 Km or 1 year	300 hours or 1 year
				MTF Gear Oil API GL-4	SAE 80W90 SAE 75W90	50,000 Km	50,000 Km or 6 months	250 hours or 6 months
				Engine Oil API-CD	SAE 50 SAE 40 SAE 30			
				MIL-2104H				
				CAT TO-4				

**India**

For a list of approved Extended Service Interval Lubricant Suppliers, visit [www.Roadranger.com/Lubricants](http://www.Roadranger.com/Lubricants) to download TCMT0020.

Product	Transmission Torque	Service Interval	Lubricant Specification	SAE Viscosity Grade	Drain Interval	
					On-Highway / Line Haul	Off-Highway / Vocational / Mining
Manual Transmission	All	Extended	PS-386	N/A	300,000 Km (185,000 mi) or 5 years	2,000 hours or 3 years
	All	Standard	PS-321	N/A	120,000 Km (75,000 mi) or 1 year	1,000 hours or 1 year
			Group II Mineral Oil using 7 wt% of Lubrizol Anglamol 6097	SAE 80W90	100,000 Km (60,000 mi) or 1 year	1,000 hours or 1 year
			Group II Mineral Oil using 7 wt% of Lubrizol Anglamol 2026 (see Note 1)	SAE 80W90	80,000 Km (50,000 mi) or 1 year	1,000 hours or 1 year
			Group II Mineral Oil using 3.75 wt% of Afton HiTEC 381 and 0.3wt% of Afton HiTEC 382 (See Note 1)			

**Note:** 1. Oil samples should be taken from the center of the transmission with oil at operating temperature using a suitable syringe.

**Note:** Oil sampling to take place at 20,000-30,000 Km.

**Note:** DO NOT USE ADDITIVES OR FRICTION MODIFIERS.

## Africa and Middle East

For a list of approved Extended Service Interval Lubricant Suppliers, visit [www.Roadranger.com/Lubricants](http://www.Roadranger.com/Lubricants) to download TCMT0020.

Product	Transmission Torque	Service Interval	Lubricant Specification	SAE Viscosity Grade	Drain Interval			
					Line Haul	Vocational	Bus	Stationary
Hybrid	All	Extended	Eaton PS-386	N/A	N/A	N/A	300,000 Km or 3 years	N/A
Automated (UltraShift® PLUS)	All	Extended	Eaton PS-386	N/A	480,000 Km (See Note 3)	6,500 hours or 1 year	300,000 Km or 3 years	2,000 hours or 5 years
Medium-Duty Manual Transmission	All	Extended	Eaton PS-386	N/A	300,000 Km	6,500 hours or 1 year	300,000 Km or 2 years	N/A
Heavy-Duty Manual Transmission FR Models RT Models	All	Extended	Eaton PS-386	N/A	480,000 Km (See Note 3)	6,500 hours or 1 year	300,000 Km or 2 years	2,000 hours or 5 years
Heavy-Duty Manual Transmission FTS-10 / S10 FTS-13 / S13	All	Extended	Eaton PS-386	N/A	300,000 Km (See Note 3)	6500 hours or 1 year	200,000 Km or 2 years	2,000 hours or 5 years
Heavy-Duty Manual Transmission FR Models RT Models	< 1850 lb-ft (2500N•m)	Standard	Eaton PS-321	N/A	100,000 Km or 1 year	N/A	100,000 Km or 1 year	600 hours or 1 year
Heavy-Duty Manual Transmission FTS-10 / S10 FTS-13 / S13	All	Standard	MTF Gear Oil API GL-4	SAE 80W90 SAE 75W90	60,000 Km (See Note 1)	N/A	60,000 Km or 1 year (See Note 1)	500 hours or 1 year (See Note 2)
Medium-Duty Manual Transmission			Engine Oil API-CD	SAE 50 SAE 40 SAE 30				
			MIL-2104H					
			CAT TO-4					

**Recommended:** 20,000 km service interval, check oil level and inspect for leaks.

**Note:** 1. Standard service interval lubricants require an initial drain prior to regular drain intervals:

First oil drained after first 5,000 to 10,000 Km on all models except: FS(O)4106, FS(O)5206, ES11X09, ES012X09, FS(O)10309, ES(O)1X409, ES020409.

2. Standard service interval lubricants require an initial drain prior to regular drain intervals:

First oil drained after first 40 hours or 2 months on all models except: FS(O)4106, FS(O)5206, ES11X09, ES012X09, FS(O)10309, ES(O)1X409, ES020409.

3. When ambient temperatures routinely exceed 45 °C (more than 100 days per year) use Extended Drain Lubricants and:

a. Reduce drain intervals to 250,000 Km

b. -or- perform oil sample analysis at every 60,000 Km to check for lubricant oxidation.

**This page intentionally blank**

## Eaton Hydraulic Launch Assist Lubrication Requirements

Regular maintenance is important for safe and reliable operation of the Eaton HLA system. A preventative maintenance (PM) schedule should be used to ensure the longest performance.

Follow maintenance procedures as described in the HLA service manual, TRSM1200.

### Lubricant Drain Interval List

HLA System Component	Maintenance Requirement	Component	Maintenance / Drain Interval (hours)	
			2,400	12,000
Transfer Case	Lubricant Change	Roadranger FE 75W-90 (1.9 gallons)		X
HLA System Fluid	Lubricant Change	Roadranger HLA High Performance Hydraulic Fluid (21 gallons)	X	
HLA System Filters	Change System Oil Filter	Part # 6025270-001	X	
	Change Secondary Oil Filter	Part # 5994113-001	X	
Reservoir Breather	Change Breather	Part #5998865-001	X	

**This page intentionally blank**

## Eaton Clutch Lubrication Requirements

Failure to properly lubricate the bearing/bushing will result in bearing and bushing failures.

- Consult the appropriate Clutch Service Manual for detailed explanation of the lubrication techniques.
- Regular grease service intervals are required to purge the debris from the grease.
- If not properly maintained, the debris can become hard and prevent the flow of grease when serviced.

Pictured are examples of failures due to incompatible greases:

### Release Bearing Failure

The photo below shows the release bearing where the majority of the grease has disappeared. This is likely due to using grease with a lower operating temperature or using an incompatible grease. When the release bearing gets hot, the grease “melts” and does not provide adequate lubrication.



### Debris Close-Up

The photo below is a close-up of the debris in the grease. The debris contains hard particles, is damaging to the bearing, and will cause premature failures.

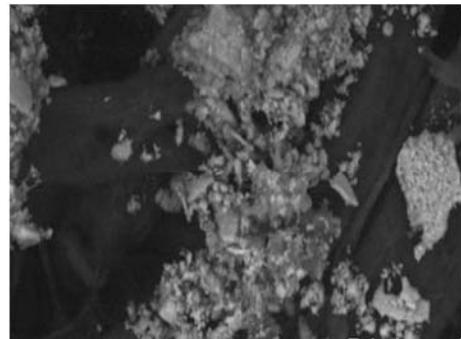

### Grease Contaminated with Debris

The photo below shows a release bearing with grease that is contaminated with debris. It is very important to grease at regular service intervals to purge the debris from the bearing.



## Grease Information

Greases available to the trucking industry are not created equal, and many are formulated for specific applications. Just reading the information on the label on the container may not be enough to determine if the grease used by customers for maintenance is compatible with greases used in Eaton clutch products.

### What To Look For When Selecting Grease

Look for these 3 things:

1. Grade (Consistency)
2. Thickener Type (Compatibility)
3. Performance

### Grade (Consistency)

The NLGI grade of grease refers to its consistency. It is measured by dropping a weighted cone into the grease per ASTM D217. The depth the cone penetrates into the grease is called the consistency. The NLGI grade refers to a range of depths the cone penetrates into the grease.

The chart below is a helpful reference to understand the consistency and appearance of a grease based on the NLGI Grade.

NLGI Grade	Appearance	Consistency
000	Fluid	Cooking oil
00	Fluid	Applesauce
0	Very soft	Brown mustard
1	Soft	Tomato paste
2	Moderately soft	Peanut butter
3	Semi-fluid	Vegetable shortening
4	Semi-hard	Frozen yogurt
5	Hard	Smooth pate
6	Very hard	Cheddar cheese spread

### Thickener Type (Compatibility)

When greases of different thickener types are mixed, undesired results may occur. When the mixture of the greases changes the performance properties, then the two greases are considered incompatible.

Greases are considered “compatible” when these parameters don't change when mixed:

- Grade (Consistency)
- Lower Heat Resistance
- Less Shear Stability
- Decrease in Additive Performance

The use of a grease that is not compatible with the Roadranger Grease EP-2 Lithium-Complex grease can result in premature release bearing failures.

**Note:** Calcium Sulfonate Type Greases have been shown to be incompatible with the Roadranger Grease EP-2 Lithium Complex Type. Use of Calcium Sulfonate Type Grease will reduce the life of Eaton Clutch release bearings.



## Performance

NLGI developed designations and performance descriptions for service grease categories. These categories are defined per ASTM D4950 and include the lubrication of wheel bearings and chassis components.

An “L” designation includes such things as ball joints, steering pivots, universal joints and other chassis components, and a “G” designation includes wheel bearing greases. Each class (L and G prefix) are further divided into categories based on service needs. The most demanding service category is designated by defining both classes (L and G) and the highest alphabetical nomenclature for the class. The GC-LB service category defines multi-purpose grease suitable for both chassis and bearing service applications.

The symbol below is provided from NLGI to designate the service performance quality of a grease. It is not always found on the packaging. Often, a reference to the specification is found on the product datasheet.



G - Designation is for bearings

L - Designation is for chassis components

## Clutch Lubrication Procedure

1. Each Clutch model has specific lubrication requirements. **Consult the appropriate Clutch Service Manual for detailed instructions.**
2. Clutches typically need service lubrication in the following areas:

- **Release Bearing**

The release bearing is greased through a grease Zerk fitting on the clutch housing or by a grease hose extension tube. On some models, the Zerk fittings are labeled RS (release bearing) on the clutch housing case. Removal of the inspection cover is typically necessary to access the extension lube tube.

Apply grease until it purges from the release bearing housing and onto the transmission input shaft.

**Note:** Failed grease hoses will prevent grease from reaching the release bearing, causing premature failure.

- **Release Fork Wear Pads**

The release fork has hardened steel pads where it contacts the release bearing housing. Apply a small amount of grease to the surface of these pads.

- **Clutch Brake**

The clutch brake friction material is designed to operate with lubricant. While lubricating the release bearing, grease should purge from the

housing and contact the clutch brake. If desired, a small amount of grease could be applied to both sides of the clutch brake.

**Note:** Do not be concerned if excess grease gets onto the clutch brake friction surface or the LCIB friction surface. It will not affect the brake's stopping ability.

- **Cross-Shaft Bushings**

The cross shaft bushings are greased through a grease Zerk fitting on the side of the clutch housing or by a grease hose extension tube. On some models, the Zerk fittings are labeled CS (Cross shaft) on the clutch housing case. Removal of the inspection cover is typically necessary to access the extension lube tube.

Apply grease until it can be seen at the cross-shaft bushing weep hole bushings.

- **Clutch Control Linkage**

Refer to specific OEM requirements to lubricate the bell crank and pivot pins.

- **Pilot Bearing**

The pilot bearing inside the flywheel does not require lubrication.

**Note:** DO NOT apply lubricant (grease or anti-seize) to the input shaft splines. The disc must be free to slide.

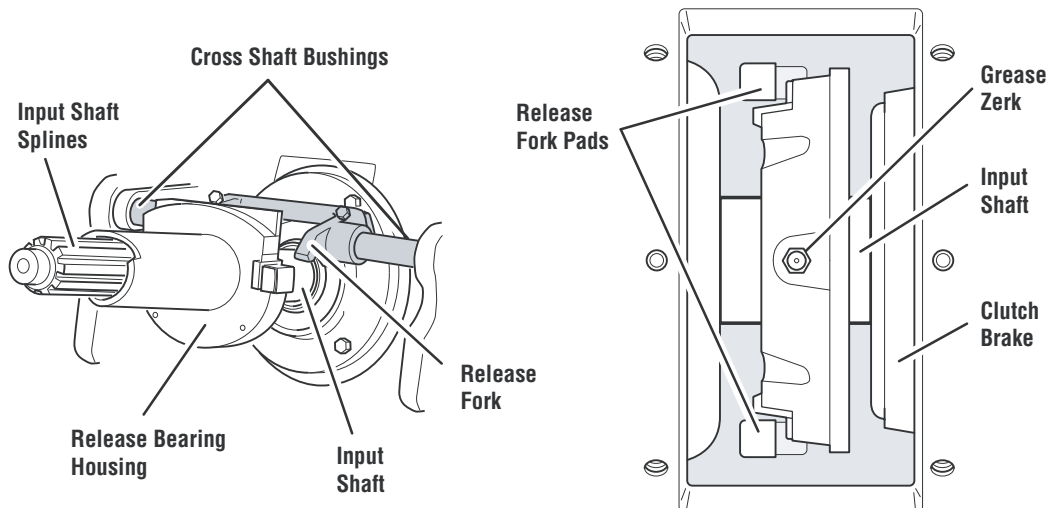

## Eaton Clutch Lubrication and Service Interval List

Use the chart below by selecting the Eaton Clutch product to service. The application (line haul and vocational) definitions are located earlier in this manual.

**DO NOT mix other thickener type greases. It has been shown that certain Calcium Sulfonate Type greases are not compatible with Lithium Complex Type greases and cause premature bearing failures. For more information about selecting the correct grease, see “What To Look For When Selecting Grease” on page 20.**

Product	NLGI Grade	Thickener Type	Performance Rating	Grease Interval: Line Haul (see Note 2 and 3)	Grease Interval: Vocational (see Note 2 and 3)
Stamped Angle Spring	NLGI #2 or #3	Lithium Complex	NLGI GC-LB	10,000 miles max (16,000 km)	250 hours or 1 month
Medium-Duty Solo™					
430mm Endurant™	No Lubricant Needed				
365 mm (see Note 1)					
395 mm (see Note 1)					
EverTough	NLGI #2 or #3	Lithium Complex	NLGI GC-LB	25,000 miles max (40,000 km)	250 hours or 1 month
Heavy-Duty ECA Clutch	NLGI #2 or #3	Lithium Complex	NLGI GC-LB	50,000 miles max (80,000 km)	250 hours or 1 month
Solo™ Advantage					
Easy Pedal™ Advan- tage					
Value Clutch	NLGI #2 or #3	Lithium Complex	NLGI GC-LB	20,000 miles max (32,000 km)	250 hours or 1 month
Reman Solo Clutch					
Reman Easy Pedal Clutch					
DM	No Lubricant Needed				
Pedal Shaft /Bushings	NLGI #2	Lithium Complex	NLGI GC-LB	At every chassis lubrication	At every chassis lubrication

- Note:**
- Grease the ECA Cross Shaft at vehicle chassis lubrication maintenance intervals.
  - Frequent lubrication of the release bearing is required for severe-duty cycles.
  - If the vehicle has been out of service for an extended period of time, lubrication of the clutch release bearing and clutch linkage is required prior to returning to service.

## Change Control Log

Date	Description
October 2017	<p>Added Endurant table to <i>Heavy Duty Transmission Lubricant Capacities</i></p> <p>Added Endurant to <i>Eaton Transmission and Lubricant Drain Interval List - NAFTA</i></p> <p>Corrected PS-386 SAE Viscosity Grade on <i>Eaton Transmission and Lubricant/Drain Interval List - NAFTA</i> table under Manual Transmission Medium-Duty product line</p> <p>Added 430mm Endurant to <i>Eaton Clutch Lubrication and Service Interval List</i></p>
January 2017	<p>Updated for PS-386 replacement of PS-164rev7 effective January 1, 2017.</p>
January 2016	<p>Added ES and ESO models to <i>Medium Duty Transmission Lubricant Capacities</i>, model numbers: 4106, 5206, 10309, 11109, 11209, 12109, 12209, 15409, 20409.</p> <p>Updated <i>Eaton Transmission Lubricant and Drain Interval Lists for Europe and Africa and Middle East</i> tables (Notes 1 and 2).</p>
October 2015	<p>Corrected Manual Transmission, Heavy-Duty with Below 1,850 lb-ft (2,500 Nm) PS-386 Stationary Drain Interval to 2,000 hours or 5 years in <i>Eaton Transmission Lubricant and Drain Interval Lists for NAFTA</i> table.</p>
September 2015	<p>Added <i>Important Update</i> section to front of manual.</p>
	<p>Added Precision table to <i>Medium-Duty Transmission Lubricant Capacities</i>.</p>
	<p>Added Precision table to <i>Eaton Transmission Lubricant and Drain Interval Lists for NAFTA</i>.</p>
June 2015	<p>Added new product specifications PS-386 and PS-278. PS-164 rev7 obsolete.</p>
	<p>Added Precision to <i>Eaton Transmission Lubricant and Drain Interval Lists for NAFTA</i></p>
	<p>Removed <i>Hydraulic Launch Assist (HLA) High Performance Fluid, Roadranger Grease EP-2, Roadranger Synthetic Gear Axle Lubricants</i></p>
October 2013	<p>Added Fuller Advantage® Series to <i>Transmission Lubrication Capacities</i> and <i>Eaton Transmission Lubricant and Drain Interval Lists for NAFTA</i></p>
	<p>Updated <i>Eaton Transmission Lubricant and Drain Interval Lists for India</i></p>
	<p>Added Fuller SAE Viscosity Grade 75W90 under products with 80W90 to <i>Eaton Transmission Lubricant and Drain Interval Lists for Europe, Australia, Asia Pacific, Africa and Middle East</i>.</p>
	<p>Updated images for <i>Proper and Improper Fill Level with Fill Plug</i> and added image of <i>Proper Oil Level with Sight Glass</i></p>
July 2013	<p>Updated <i>Eaton Clutch Lubrication and Service Interval List</i></p>
June 2013	<p>New product specification manual for Roadranger Lubricant Products</p>

**This page intentionally blank**

Copyright Eaton, 2017. Eaton hereby grant their customers, vendors, or distributors permission to freely copy, reproduce and/or distribute this document in printed format. It may be copied only in its entirety without any changes or modifications. THIS INFORMATION IS NOT INTENDED FOR SALE OR RESALE, AND THIS NOTICE MUST REMAIN ON ALL COPIES.

**Note:** Features and specifications listed in this document are subject to change without notice and represent the maximum capabilities of the software and products with all options installed. Although every attempt has been made to ensure the accuracy of information contained within, Eaton makes no representation about the completeness, correctness or accuracy and assumes no responsibility for any errors or omissions. Features and functionality may vary depending on selected options.

For spec'ing or service assistance, call 1-800-826-HELP (4357) or visit [www.eaton.com/roadranger](http://www.eaton.com/roadranger). In Mexico, call 001-800-826-4357.

Roadranger: Eaton and trusted partners providing the best products and services in the industry, ensuring more time on the road.

Eaton  
Vehicle Group  
P.O. Box 4013  
Kalamazoo, MI 49003 USA  
800-826-HELP (4357)  
[www.eaton.com/roadranger](http://www.eaton.com/roadranger)

Printed in USA