

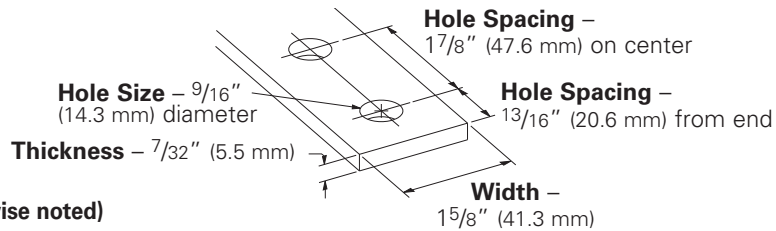

This section offers a full selection of fittings and accessories to complete our strut system. Fittings are made from hot rolled, pickled and oiled plate or strip steel in accordance with ASTM A1018 33,000 PSI min. yield, unless noted.

### Dimensions

The following dimensions apply to all fittings except as noted:



### Materials & Finishes (Unless otherwise noted)

Finish Code	Finish	Specification
PLN	Plain	ASTM A1018 33,000 PSI min. yield
ZN	Electro-Plated Zinc	ASTM B633 SC3 Type III or ASTM A653
GRN	DURA GREEN™	
HDG	Hot-Dipped Galvanized	ASTM A123
SS4	Stainless Steel Type 304	ASTM A240
SS6	Stainless Steel Type 316	ASTM A240
AL	Aluminum	ASTM B209

Note: A minimum order may apply on special material and finishes.

### Hardware

Nuts and bolts are not included with the fittings and must be ordered separately, unless noted.

### Pre-Assembled Fittings

Some fittings are available with hex head cap screws and channel nuts pre-assembled.

These fittings and finishes will be flagged using the following symbol.



**PA** <sup>ZN</sup>  
<sub>GRN</sub>

### Metric

Metric dimensions are shown in parentheses. Unless noted, all metric dimensions are in millimeters.

### Load Data

The load data published includes safety factor of 2.5 when used with 12 ga. (2.6) channel safety factor = ratio of ultimate load to the design load).

Use 1/2"-13 x 7/8" hex head cap screws and 1/2"-13 (N225 or TN225) channel nuts for the rated results.

Note: See page 277 Design Load Data for typical channel - fitting connections.

### Recommended Bolt Torque

Bolt Size	1/4"-20	5/16"-18	3/8"-16	1/2"-13
Foot/Lbs.	6	11	19	50
Nm	8	15	26	68

See chart on page 154 for setscrew torque.

### 4Dimension™ Strut System Compatible

These fittings and finishes will be flagged using the following symbol.



## B200-B202-2

- Standard finishes: ZN, GRN, HDG, SS4, SS6, AL

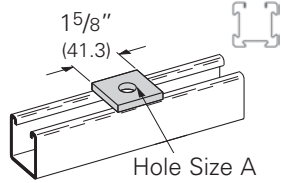

## Square Washer

Part No.	A		Bolt Size		Wt./C	
	In.	mm	In.	mm	Lbs.	kg
B200	3/8"	(9.5)	5/16"	(7.9)	18	(8.1)
B201	7/16"	(11.1)	3/8"	(9.5)	18	(8.1)
B202	9/16"	(14.2)	1/2"	(12.7)	17	(7.7)
B202-1	11/16"	(17.4)	5/8"	(15.9)	16	(7.2)
B202-2	13/16"	(20.6)	3/4"	(19.0)	15	(6.8)
B202-3	15/16"	(23.8)	7/8"	(22.2)	14	(6.3)

## B200D-B202-2D

- Standard finishes: ZN, GRN, HDG, SS4, SS6, AL

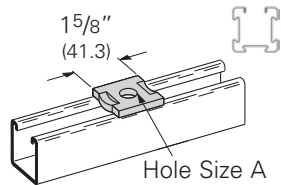

## No Twist Square Washer

Part No.	A		Bolt Size		Wt./C	
	In.	mm	In.	mm	Lbs.	kg
B200D	3/8"	(9.5)	5/16"	(7.9)	18	(8.1)
B201D	7/16"	(11.1)	3/8"	(9.5)	18	(8.1)
B202D	9/16"	(14.2)	1/2"	(12.7)	17	(7.7)
B202-1D	11/16"	(17.4)	5/8"	(15.9)	16	(7.2)
B202-2D	13/16"	(20.6)	3/4"	(19.0)	15	(6.8)

## B129

### Two Hole Splice Plate

- Standard finishes: ZN, GRN
- Wt./C 37 Lbs. (16.8 kg)

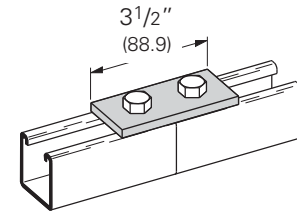

## B340

### Two Hole Splice Plate

- Standard finishes: ZN, GRN
- Wt./C 34 Lbs. (15.4 kg)

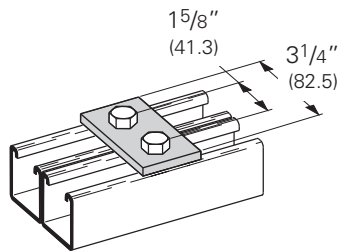

## B528

### Two Hole Splice Plate

- Standard finishes: ZN, GRN
- Wt./C 50 Lbs. (22.7 kg)

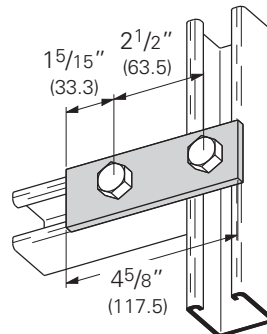

## B141

### Three Hole Splice Plate

- Standard finishes: ZN, GRN
- Wt./C 55 Lbs. (24.9 kg)

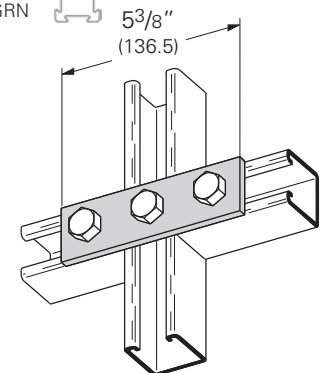

## B557

### Three Hole Splice Plate

- Standard finishes: ZN, GRN
- Wt./C 50 Lbs. (22.7 kg)

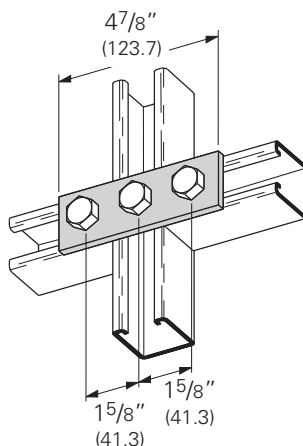

## B341

### Four Hole Splice Plate

- Standard finishes: ZN, GRN, HDG
- Wt./C 76 Lbs. (34.5 kg)

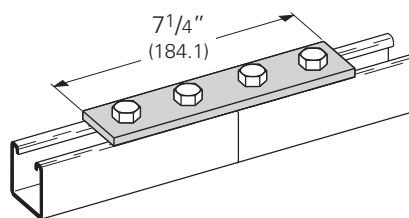

## B342

### Five Hole Splice Plate

- Standard finishes: ZN, GRN
- Wt./C 96 Lbs. (43.5 kg)

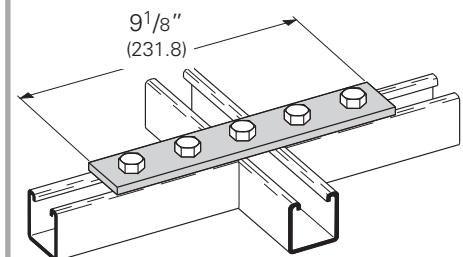

PA Pre-assembled fitting



4Dimension compatible fitting

Reference page 106 for general fitting and standard finish specifications.

# Flat Plate Fittings

## B138 Two Hole Swivel Plate

- Standard finishes: ZN, GRN
- Wt./C 48 Lbs. (21.8 kg)

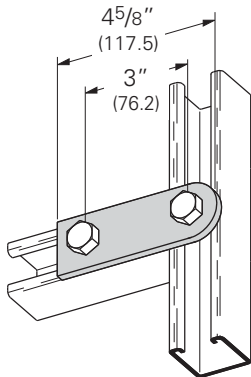

## B139 Three Hole Swivel Plate

- Standard finishes: ZN, GRN
- Wt./C 69 Lbs. (31.3 kg)

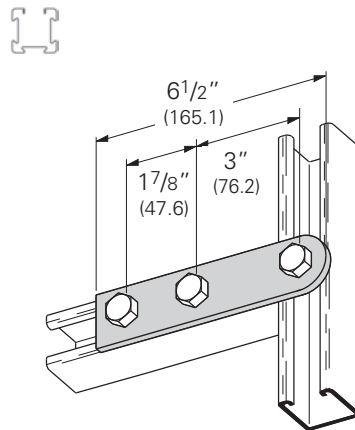

## B504 Four Hole Splice Plate

- Standard finishes: ZN, GRN
- Wt./C 73 Lbs. (33.1 kg)

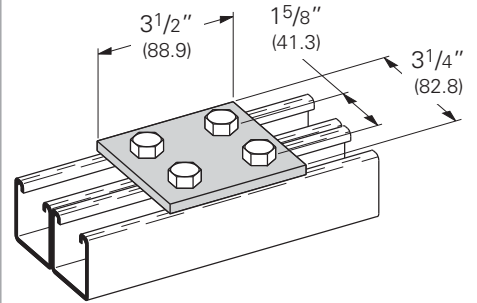

## B140 Three Hole Corner Plate

- Standard finishes: ZN, GRN, HDG, SS4
- Wt./C 56 Lbs. (25.4 kg)

PA ZN  
GRN

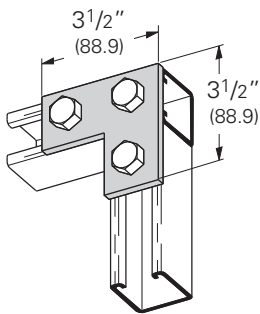

## B143 Four Hole Corner Plate

- Standard finishes: ZN, GRN, HDG, SS4
- Wt./C 75 Lbs. (34.0 kg)

PA ZN  
GRN

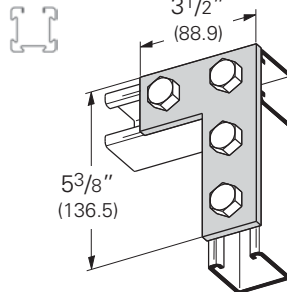

## B133 Four Hole Tee Plate

- Standard finishes: ZN, GRN, HDG, SS4, AL
- Wt./C 75 Lbs. (34.0 kg)

PA ZN  
GRN

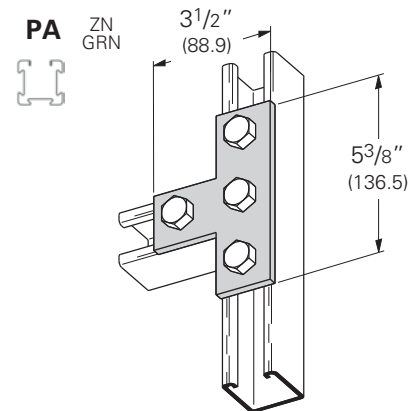

## B132 Five Hole Cross Plate

- Standard finishes: ZN, GRN, HDG
- Wt./C 100 Lbs. (45.3 kg)

PA ZN  
GRN

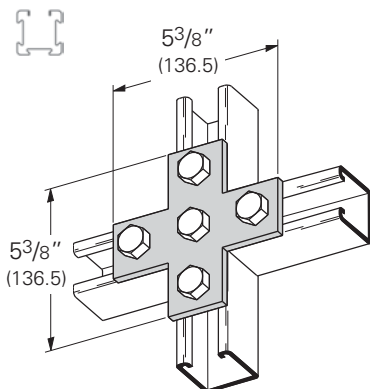

## B135 Three Hole Corner Gusset Plate

- Standard finishes: ZN, GRN
- Wt./C 70 Lbs. (31.7 kg)

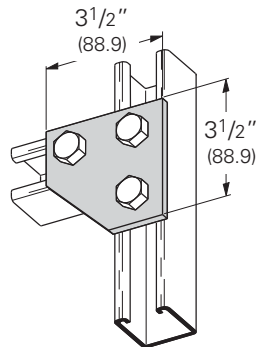

## B142 Four Hole Corner Gusset Plate

- Standard finishes: ZN, GRN, HDG
- Wt./C 102 Lbs. (46.2 kg)

PA ZN  
GRN

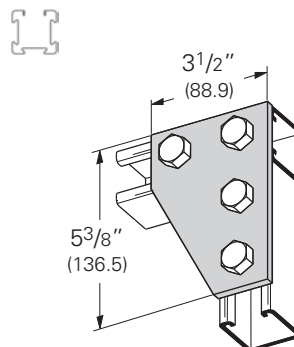

PA Pre-assembled fitting

 4Dimension compatible fitting

Reference page 106 for general fitting and standard finish specifications.

**B137**  
**Four Hole Corner Gusset Plate**

- Standard finishes: ZN, GRN
- Wt./C 273 Lbs. (123.8 kg)

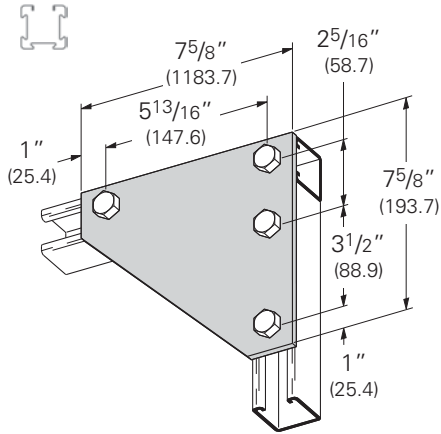

**B556**  
**Five Hole Corner Gusset Plate**

- Standard finishes: ZN, GRN
- Wt./C 145 Lbs. (65.8 kg)

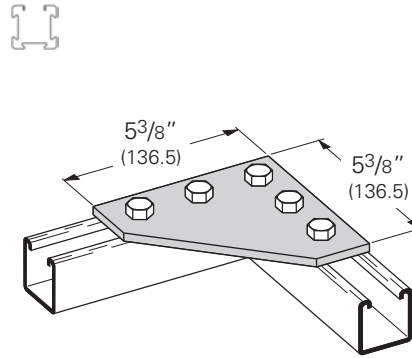

**B337**  
**Three Hole Tee Gusset Plate**

- Standard finishes: ZN, GRN
- Wt./C 70 Lbs. (31.7 kg)

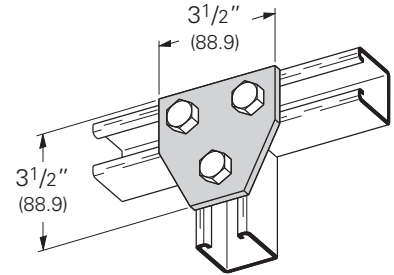

**B432**  
**Four Hole Tee Gusset Plate**

- Standard finishes: ZN, GRN
- Wt./C 100 Lbs. (45.3 kg)

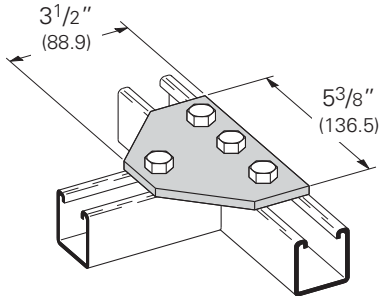

**B136**  
**Four Hole Tee Gusset Plate**

- Standard finishes: ZN, GRN, HDG
- Wt./C 100 Lbs. (45.3 kg)

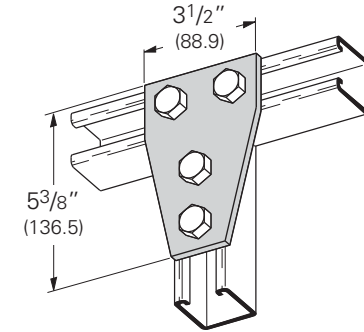

**B532**  
**Five Hole Tee Gusset Plate**

- Standard finishes: ZN, GRN
- Wt./C 143 Lbs. (64.8 kg)

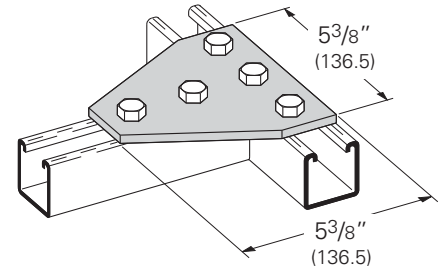

**B339**  
**Six Hole Tee Gusset Plate**

- Standard finishes: ZN, GRN
- Wt./C 149 Lbs. (67.6 kg)

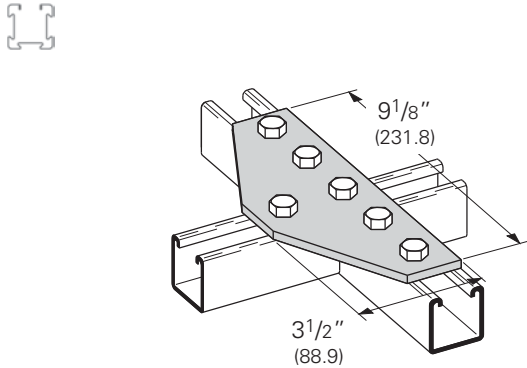

**B334**  
**Seven Hole Cross Gusset Plate**

- Standard finishes: ZN, GRN
- Wt./C 232 Lbs. (105.2 kg)

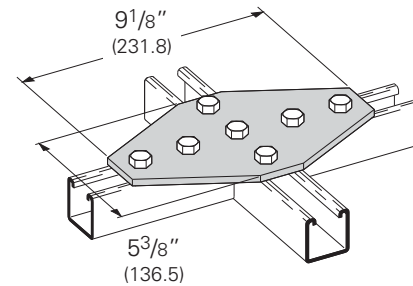

PA Pre-assembled fitting

 Dimension compatible fitting

Reference page 106 for general fitting and standard finish specifications.

# 90° Angle Fittings

## B420-378 One Hole Corner Angle

- Standard finishes: ZN, GRN
- Wt./C 60 Lbs. (27.2 kg)

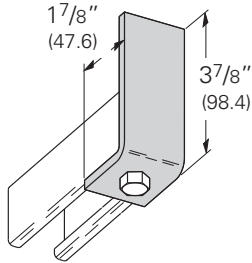

## B420-578 One Hole Corner Angle

- Standard finishes: ZN, GRN
- Wt./C 85 Lbs. (38.5 kg)

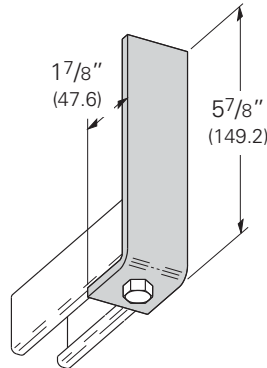

## B420-778 One Hole Corner Angle

- Standard finishes: ZN, GRN
- Wt./C 107 Lbs. (48.5 kg)

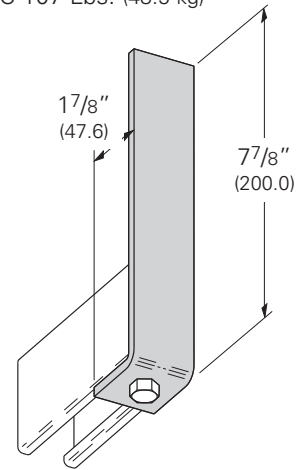

## B420-978 One Hole Corner Angle

- Standard finishes: ZN, GRN
- Wt./C 129 Lbs. (58.5 kg)

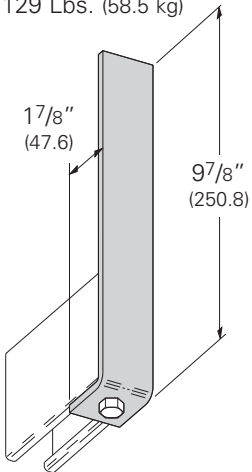

## B101 Two Hole Corner Angle

- Standard finishes: ZN, GRN, HDG, SS4, AL
- Wt./C 37 Lbs. (16.8 kg)

PA ZN GRN

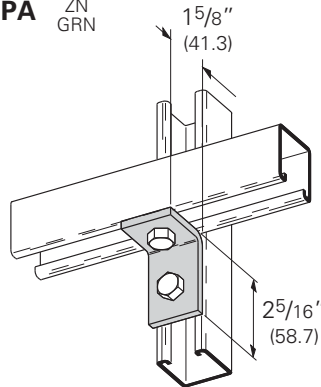

## B230 Two Hole Corner Angle

- Standard finishes: ZN, GRN, HDG, SS4, AL
- Wt./C 37 Lbs. (16.8 kg)

PA ZN GRN

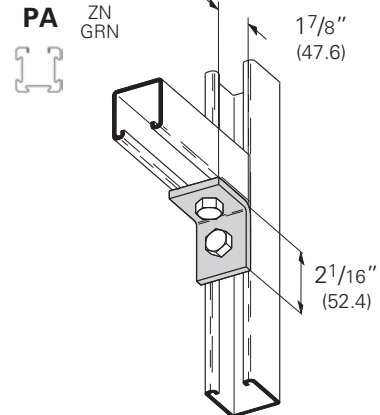

## B231 Two Hole "No-Twist" Corner Angle

- Standard finishes: ZN, GRN, HDG
- Wt./C 41 Lbs. (18.6 kg)

PA ZN GRN

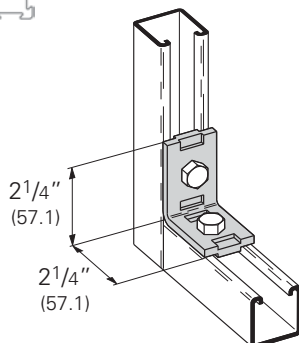

## B359 Two Hole Corner Angle

- Standard finishes: ZN, GRN
- Wt./C 48 Lbs. (21.8 kg)

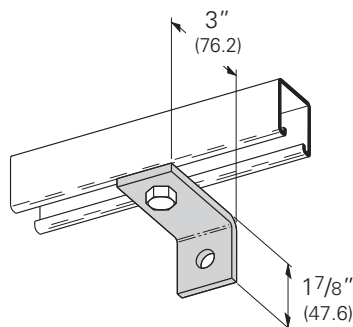

## B360 Two Hole Corner Angle

- Standard finishes: ZN, GRN
- Wt./C 53 Lbs. (24.0 kg)

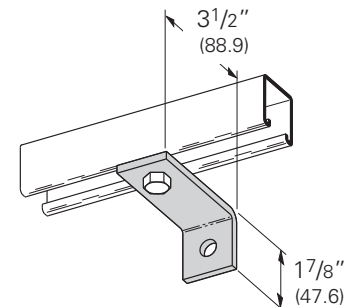

PA Pre-assembled fitting



4Dimension compatible fitting

Reference page 106 for general fitting and standard finish specifications.

## B361 Two Hole Corner Angle

- Standard finishes: ZN, GRN
- Wt./C 60 Lbs. (27.2 kg)

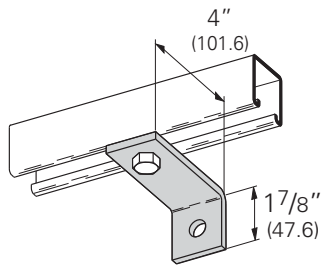

## B102 Three Hole Corner Angle

- Standard finishes: ZN, GRN, HDG, SS4
- Wt./C 56 Lbs. (25.4 kg)

PA ZN  
GRN

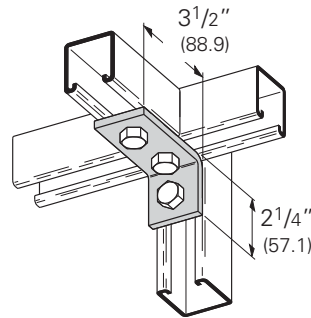

## B103 Three Hole Corner Angle

- Standard finishes: ZN, GRN, HDG, SS4
- Wt./C 56 Lbs. (25.4 kg)

PA ZN  
GRN

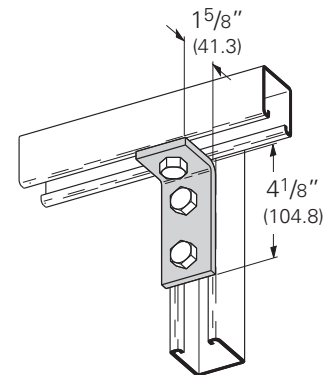

## B232 Three Hole Corner Angle

- Standard finishes: ZN, GRN, HDG, SS4
- Wt./C 56 Lbs. (25.4 kg)

PA ZN  
GRN

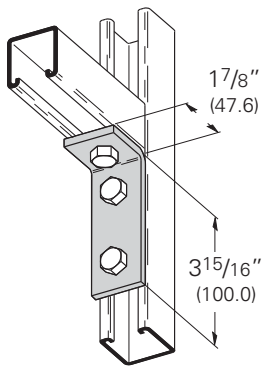

## B374 Three Hole Corner Angle

- Standard finishes: ZN, GRN, HDG
- Wt./C 56 Lbs. (25.4 kg)

PA ZN  
GRN

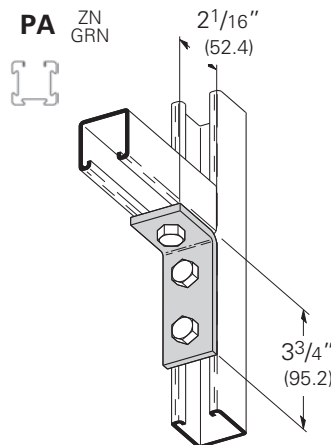

## B529 Three Hole Corner Angle

- Standard finishes: ZN, GRN
- Wt./C 78 Lbs. (35.4 kg)

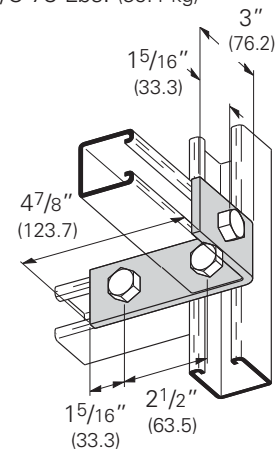

## B104 Four Hole Corner Angle

- Standard finishes: ZN, GRN, HDG, SS4, SS6, AL
- Wt./C 78 Lbs. (35.4 kg)

PA ZN  
GRN

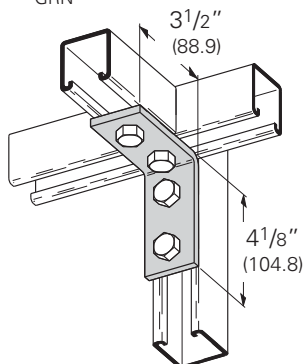

## B115 Four Hole Corner Angle

- Standard finishes: ZN, GRN, HDG, SS4, AL
- Wt./C 76 Lbs. (34.5 kg)

PA ZN  
GRN

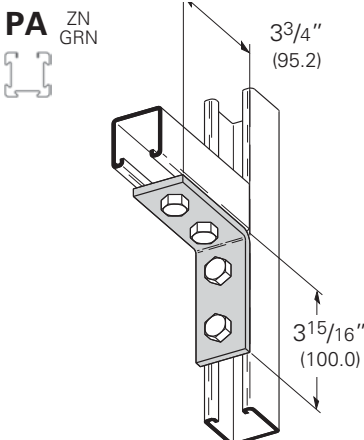

## B558 Four Hole Corner Angle

- Standard finishes: ZN, GRN
- Wt./C 73 Lbs. (33.1 kg)

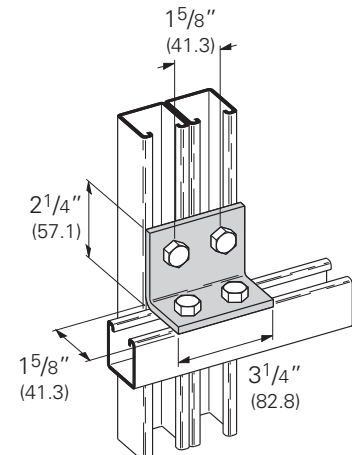

PA Pre-assembled fitting



4Dimension compatible fitting

Reference page 106 for general fitting and standard finish specifications.

# 90° Angle Fittings

## B235R Three Hole (Right Hand) Offset Bent Angle

- 1<sup>5</sup>/<sub>8</sub>" (41.3) from center to center of the holes that are shown with bolt heads
- Standard finishes: ZN, GRN
- Wt./C 53 Lbs. (24.0 kg)

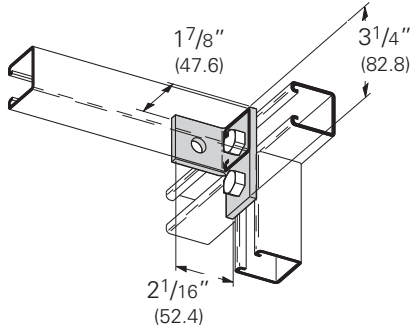

## B235L Three Hole (Left Hand) Offset Bent Angle

- 1<sup>5</sup>/<sub>8</sub>" (41.3) from center to center of the holes that are shown with bolt heads
- Standard finishes: ZN, GRN
- Wt./C 53 Lbs. (24.0 kg)

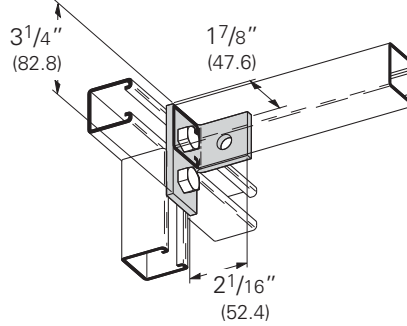

## B236R Three Hole (Right Hand) Offset Bent Angle

- Standard finishes: ZN, GRN
- Wt./C 65 Lbs. (29.5 kg)

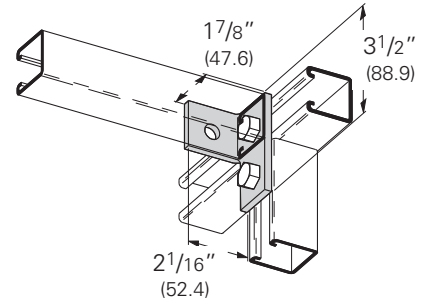

## B236L Three Hole (Left Hand) Offset Bent Angle

- Standard finishes: ZN, GRN
- Wt./C 65 Lbs. (29.5 kg)

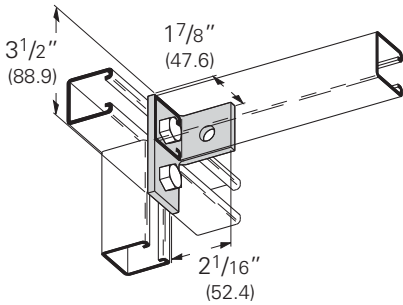

## B237 Three Hole Offset Bent Tee

- Standard finishes: ZN, GRN
- Wt./C 71 Lbs. (32.2 kg)

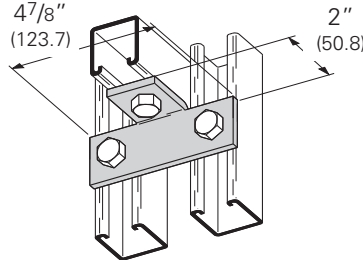

## B357 Four Hole Offset Bent Tee

- Standard finishes: ZN, GRN
- Wt./C 77 Lbs. (34.9 kg)

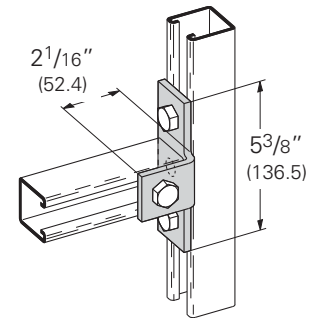

## B238R Four Hole (Right Hand) Offset Bent Tee

- Standard finishes: ZN, GRN
- Wt./C 76 Lbs. (34.5 kg)

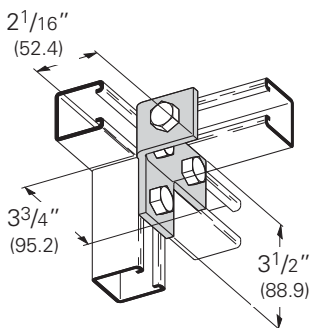

## B238L Four Hole (Left Hand) Offset Bent Tee

- Standard finishes: ZN, GRN
- Wt./C 76 Lbs. (34.5 kg)

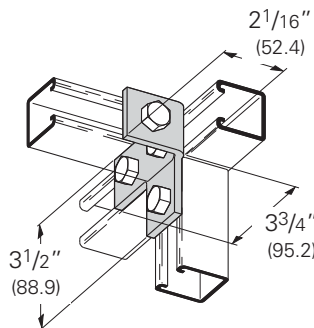

## B239 Five Hole Offset Bent Tee

- Standard finishes: ZN, GRN
- Wt./C 96 Lbs. (43.5 kg)

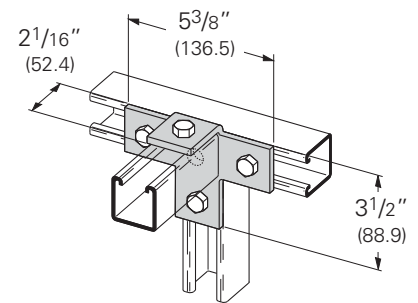

Reference page 106 for general fitting and standard finish specifications.

**B844**  
**Universal Shelf Bracket**

- Standard finishes: ZN, GRN, HDG, SS4
- Wt./C 132 Lbs. (59.9 kg)

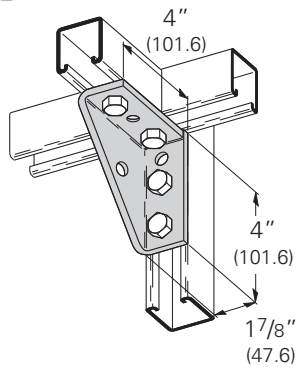

**B844W**  
**Universal Shelf Bracket - Welded**

- Standard finishes: ZN, GRN
- Wt./C 134 Lbs. (60.8 kg)

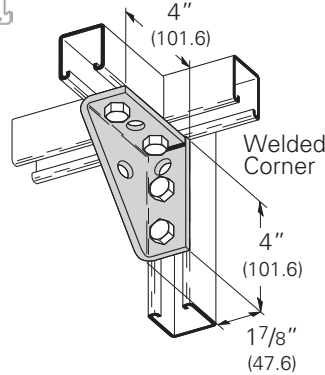

**B888W**  
**Universal Shelf Bracket - Welded**

- Standard finishes: ZN, GRN
- Wt./C 197 Lbs. (89.4 kg)

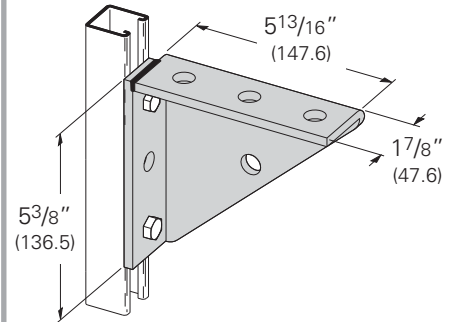

**B234R**  
**Four Hole (Right Hand) Corner Gusset**

- Standard finishes: ZN, GRN, HDG
- Wt./C 100 Lbs. (45.3 kg)

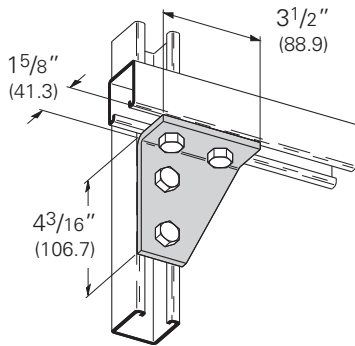

**B234L**  
**Four Hole (Left Hand) Corner Gusset**

- Standard finishes: ZN, GRN, HDG
- Wt./C 100 Lbs. (45.3 kg)

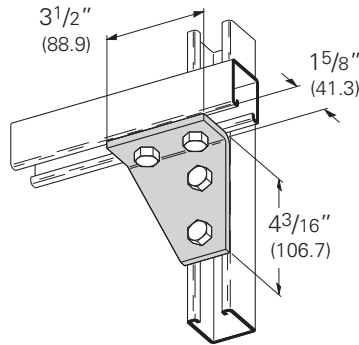

**B134R**  
**Four Hole (Right Hand) Corner Gusset**

- Standard finishes: ZN, GRN
- Wt./C 100 Lbs. (45.3 kg)

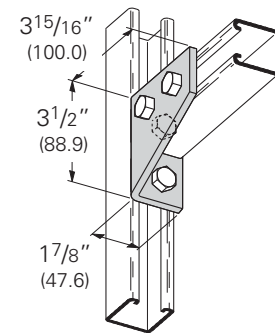

**B134L**  
**Four Hole (Left Hand) Corner Gusset**

- Standard finishes: ZN, GRN
- Wt./C 100 Lbs. (45.3 kg)

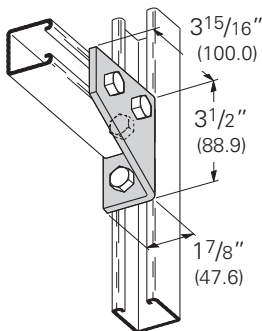

**B125**  
**Three Hole Gussetted Shelf Angle**

- Standard finishes: ZN, GRN
- Wt./C 67 Lbs. (30.4 kg)

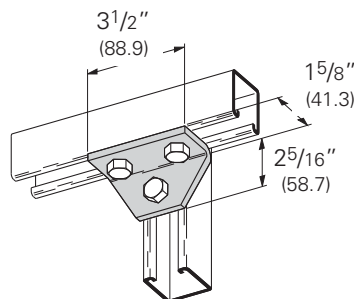

**B118**  
**Four Hole Gussetted Shelf Angle**

- Standard finishes: ZN, GRN, HDG
- Wt./C 102 Lbs. (46.2 kg)

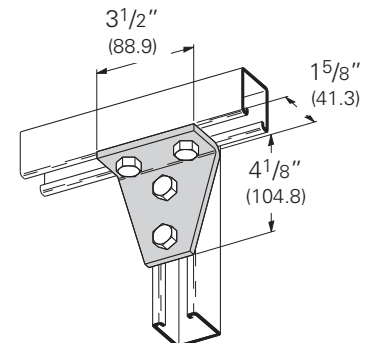

Reference page 106 for general fitting and standard finish specifications.



# 90° Angle Fittings

## B485 Four Hole Gussetted Shelf Angle

- Standard finishes: ZN, GRN
- Wt./C 148 Lbs. (67.1 kg)

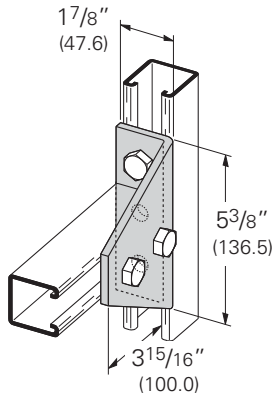

## B533 Five Hole Gussetted Shelf Angle

- Standard finishes: ZN, GRN
- Wt./C 141 Lbs. (63.9 kg)

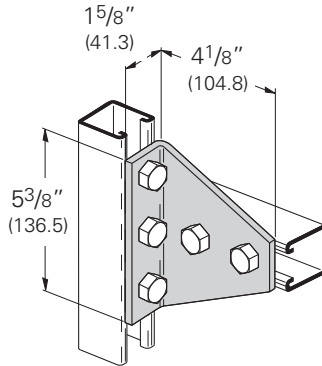

## B126 Four Hole Gussetted Three Way Shelf Angle

- Standard finishes: ZN, GRN
- Wt./C 101 Lbs. (45.8 kg)

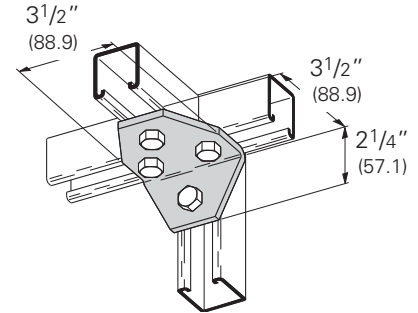

## B127 Five Hole Gussetted Three Way Shelf Angle

- Standard finishes: ZN, GRN
- Wt./C 135 Lbs. (61.2 kg)

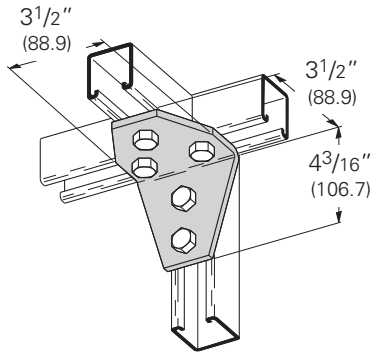

## B503R Six Hole (Right Hand) Gussetted Corner Connection

- Standard finishes: ZN, GRN
- Wt./C 229 Lbs. (103.9 kg)

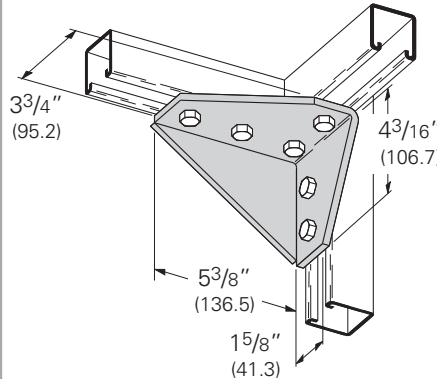

## B503L Six Hole (Left Hand) Gussetted Corner Connection

- Standard finishes: ZN, GRN
- Wt./C 229 Lbs. (103.9 kg)

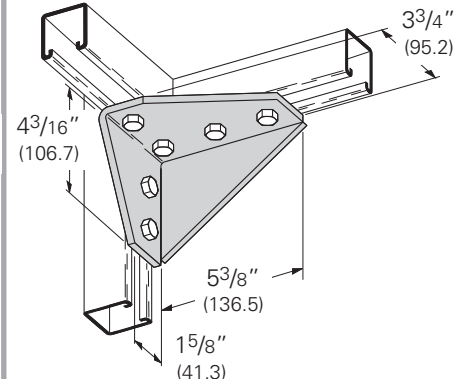

## B663 Seven Hole Gussetted Corner Connection

- Standard finishes: ZN, GRN
- Wt./C 289 Lbs. (131.1 kg)

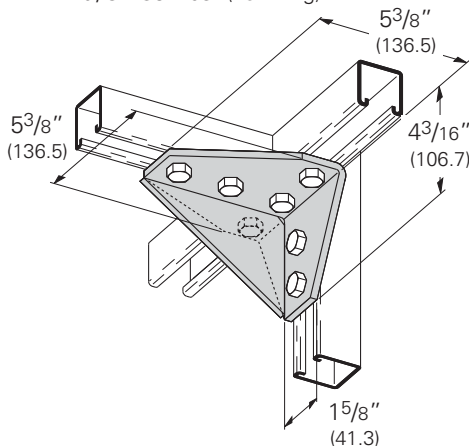

## B371 Two Hole Adjustable Corner Angle

- Standard finishes: ZN, GRN
- Wt./C 41 Lbs. (18.6 kg)

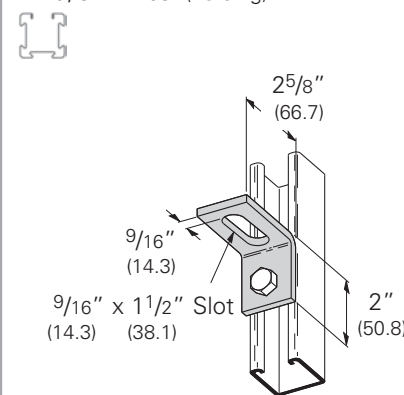

## B372 Two Hole Adjustable Corner Angle

- Standard finishes: ZN, GRN
- Wt./C 38 Lbs. (17.2 kg)

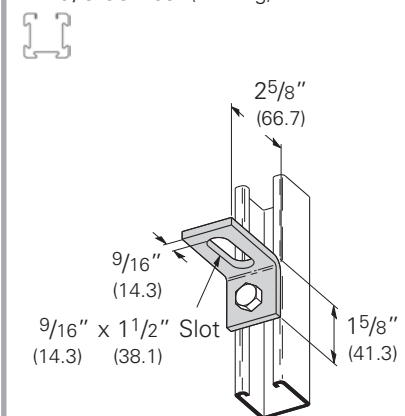

 4Dimension compatible fitting

Reference page 106 for general fitting and standard finish specifications.

**B496**  
**Two Hole Adjustable**  
**Corner Angle**

- Standard finishes: ZN, GRN
- Wt./C 85 Lbs. (38.5 kg)

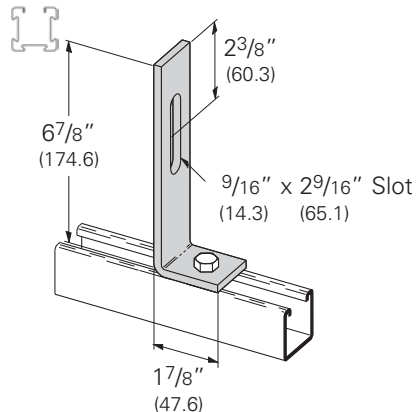

**B496-1**  
**Two Hole Adjustable**  
**Corner Angle**

- Standard finishes: ZN, GRN, HDG
- Wt./C 58 Lbs. (26.3 kg)

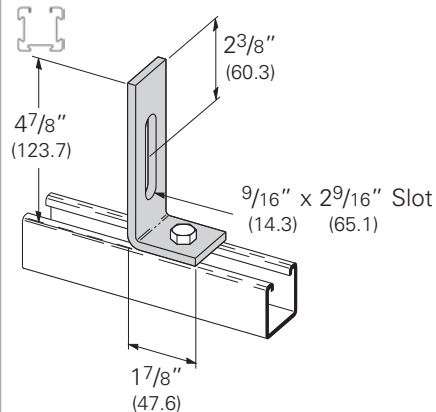

**B371-2**  
**Three Hole Adjustable**  
**Corner Angle**

- Standard finishes: ZN, GRN
- Wt./C 61 Lbs. (27.6 kg)

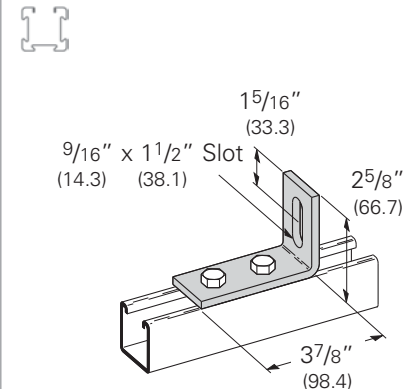

**B104SH**  
**Three Hole Adjustable**  
**Corner Angle**

- Standard finishes: ZN, GRN
- Wt./C 68 Lbs. (30.8 kg)

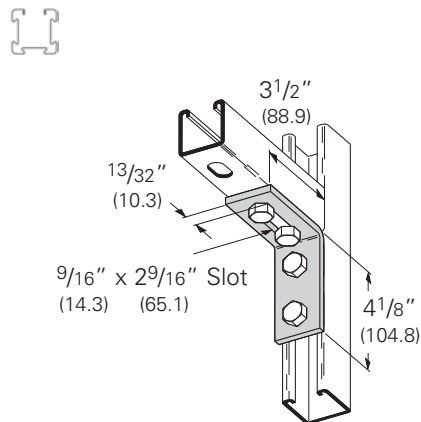

**B461**  
**Two Hole Adjustable**  
**Corner Angle**

- Standard finishes: ZN, GRN
- Wt./C 87 Lbs. (39.4 kg)

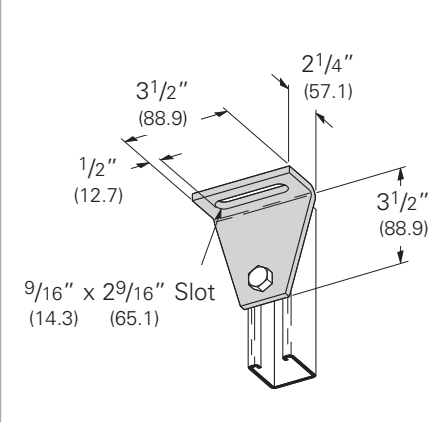

**B112**  
**Four Hole Adjustable**  
**Corner Angle**

- Standard finishes: ZN, GRN
- Wt./C 180 Lbs. (81.6 kg)

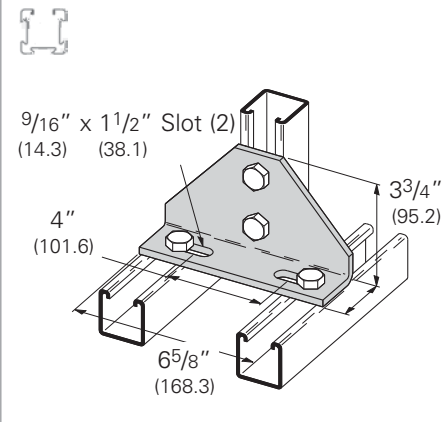

**B113**  
**Four Hole Adjustable**  
**Corner Angle**

- Standard finishes: ZN, GRN
- Wt./C 256 Lbs. (116.1 kg)

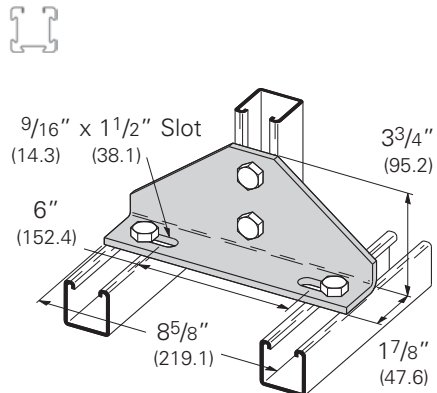

**B109S**  
**Two Hole Tapped**  
**Corner Angle**

- Standard finishes: ZN, GRN
- Wt./C 33 Lbs. (14.9 kg)

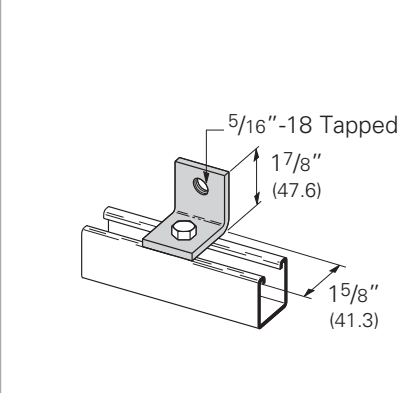

**B521**  
**Two Hole Bus Duct**  
**Angle**

- Standard finishes: ZN, GRN
- Wt./C 37 Lbs. (16.8 kg)

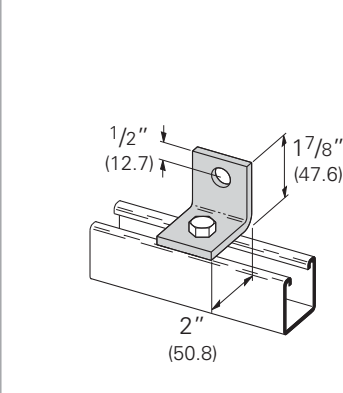

Reference page 106 for general fitting and standard finish specifications.

# Angular Fittings

## B147-B152 Two Hole Open Angle

- Standard finishes: ZN, GRN



Part No.	A	Wt./C	
		Lbs.	kg
B147	82 <sup>1</sup> / <sub>2</sub> °	63	(28.6)
B148	75°		
B149	67 <sup>1</sup> / <sub>2</sub> °		
B150	60°		
B151	52 <sup>1</sup> / <sub>2</sub> °		
B152	37 <sup>1</sup> / <sub>2</sub> °		

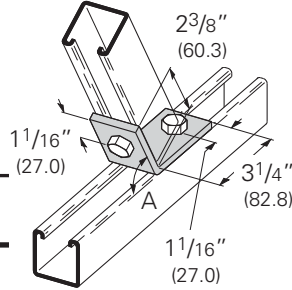

## B243-B253 Four Hole Open Angle

- Standard finishes: ZN, GRN



Part No.	A	Wt./C	
		Lbs.	kg
B243	71 <sup>1</sup> / <sub>2</sub> °	77	(34.9)
B244	15°		
B245	22 <sup>1</sup> / <sub>2</sub> °		
B246	30°		
B247	37 <sup>1</sup> / <sub>2</sub> °		
B248	45°		
B249	52 <sup>1</sup> / <sub>2</sub> °		
B250	60°		
B251	67 <sup>1</sup> / <sub>2</sub> °		
B252	75°		
B253	82 <sup>1</sup> / <sub>2</sub> °		

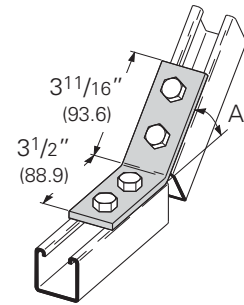

## B162-B165 Two Hole Open Angle

- Standard finishes: ZN, GRN



Part No.	A	Wt./C	
		Lbs.	kg
B162	30°	59	(26.7)
B163	22 <sup>1</sup> / <sub>2</sub> °		
B164	15°		
B165	7 <sup>1</sup> / <sub>2</sub> °		

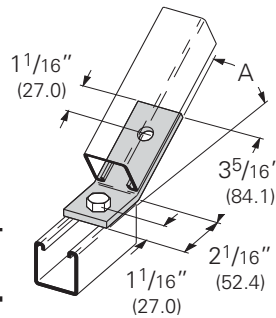

## B322-B332 Two Hole Open Short Angle

- Standard finishes: ZN, GRN



Part No.	A	Wt./C	
		Lbs.	kg
B322	71 <sup>1</sup> / <sub>2</sub> °	35	(15.9)
B323	15°		
B324	22 <sup>1</sup> / <sub>2</sub> °		
B325	30°		
B326	37 <sup>1</sup> / <sub>2</sub> °		
B327	45°		
B328	52 <sup>1</sup> / <sub>2</sub> °		
B329	60°		
B330	67 <sup>1</sup> / <sub>2</sub> °		
B331	75°		
B332	82 <sup>1</sup> / <sub>2</sub> °		

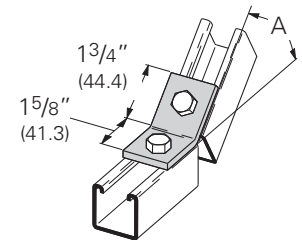

## B154 Two Hole Open Angle

- Standard finishes: ZN, GRN, SS4
- Wt./C 58 Lbs. (26.3 kg)

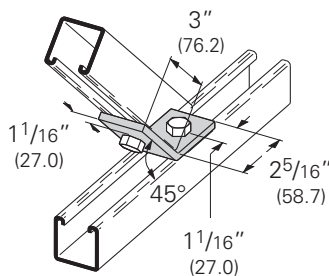

## B522 Three Hole 95° Open Angle Fitting

- Standard finishes: ZN, GRN
- Wt./C 54 Lbs. (24.5 kg)

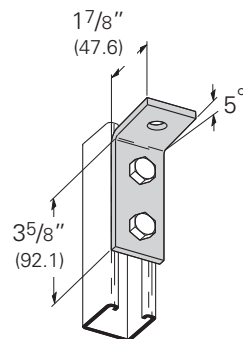

## B488 Two Hole Leg Connection

- Standard finishes: ZN, GRN
- Wt./C 100 Lbs. (45.3 kg)

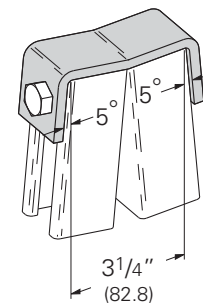

4Dimension compatible fitting

Reference page 106 for general fitting and standard finish specifications.

## B156 - B161 Two Hole Closed Angle

- Standard finishes: ZN, GRN



Part No.	A	Wt./C	
		Lbs.	kg
B156	82 <sup>1</sup> / <sub>2</sub> °	56	(25.4)
B157	75°		
B158	67 <sup>1</sup> / <sub>2</sub> °		
B159	60°		
B160	52 <sup>1</sup> / <sub>2</sub> °		
B161	37 <sup>1</sup> / <sub>2</sub> °		

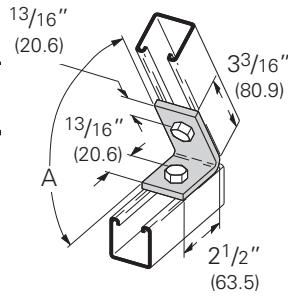

## B155 Two Hole Closed Angle

- Standard finishes: ZN, GRN, HDG, SS4
- Wt./C 63 Lbs. (28.6 kg)

PA ZN  
GRN

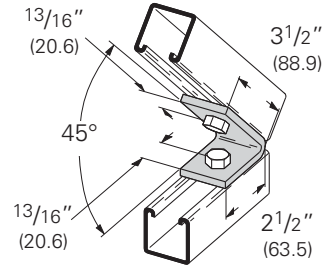

## B363 - B369 Four Hole Closed Angle

- Standard finishes: ZN, GRN



Part No.	A	Wt./C	
		Lbs.	kg
B363	82 <sup>1</sup> / <sub>2</sub> °	95	(43.1)
B364	75°		
B365	67 <sup>1</sup> / <sub>2</sub> °		
B366	60°		
B367	52 <sup>1</sup> / <sub>2</sub> °		
B368	45°		
B369	37 <sup>1</sup> / <sub>2</sub> °		

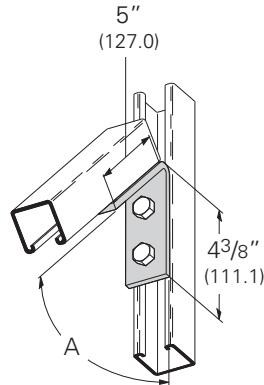

## B335-2 SERIES Three Hole Adjustable Hinge

- Standard finishes: ZN, GRN



H  
Hole Size  
This Hole Only

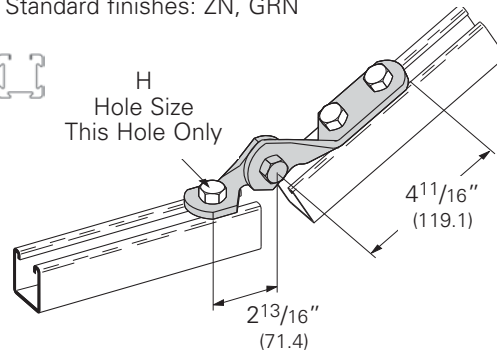

Part No. & Size	Hole Size H		Wt./C	
	In.	mm	Lbs.	kg
B335-2-3/8	7/16"	(11.1)	96	(43.2)
B335-2-1/2	9/16"	(14.3)	94	(42.3)
B335-2-5/8	11/16"	(17.4)	92	(41.4)
B335-2-3/4	13/16"	(20.6)	90	(40.5)

## B335 Four Hole Adjustable Hinge

- Standard finishes: ZN, GRN
- Wt./C 110 Lbs. (49.9 kg)

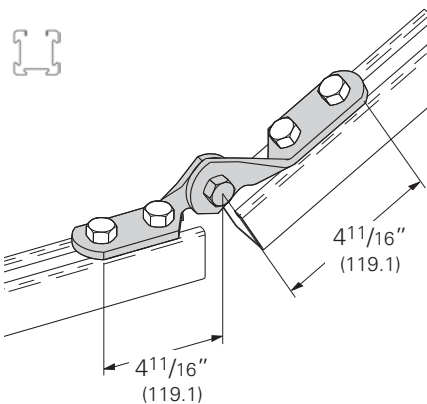

## B335V Three Hole Half Hinge

- Standard finishes: ZN, GRN



Part No. & Size	Hole Size H		Wt./C	
	In.	mm	Lbs.	kg
B335V-1/2	9/16"	(14.3)	53	(24.1)
B335V-5/8	11/16"	(17.4)	54	(24.5)
B335V-3/4	13/16"	(20.6)	55	(24.9)

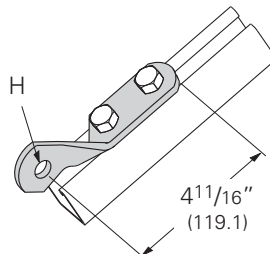

## B335-1 Two Hole Adjustable Hinge

- Standard finishes: ZN, GRN
- Wt./C 78 Lbs. (35.4 kg)

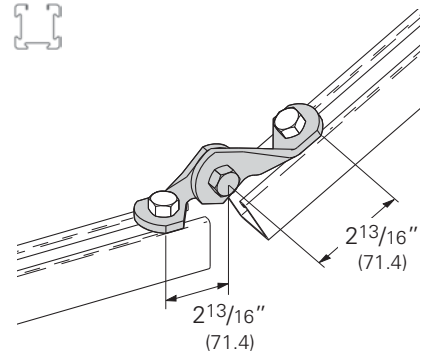

PA Pre-assembled fitting    Dimension compatible fitting

Reference page 106 for general fitting and standard finish specifications.

# Angular Fittings

## B634 Single Channel Adjustable Brace

- Standard finishes: ZN, GRN
- Wt./C 306 Lbs. (138.8 kg)

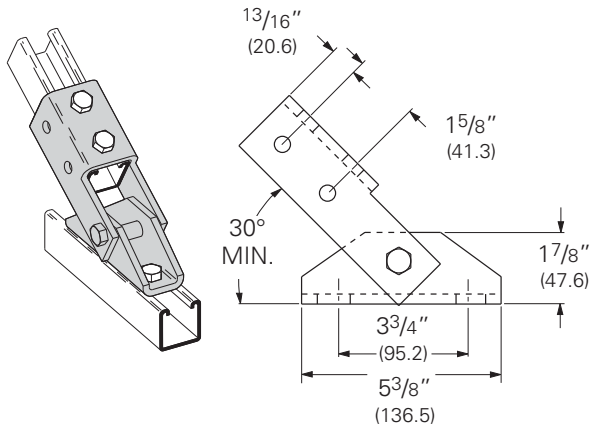

## B635 Double Channel Adjustable Brace

- Standard finishes: ZN, GRN
- Wt./C 518 Lbs. (234.9 kg)

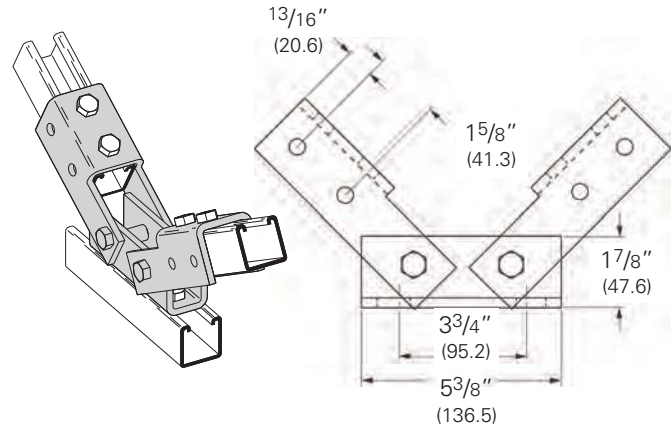

## B650 SERIES Seismic Retrofit Bracket

- Available for 3/8", 1/2", 5/8", and 3/4" threaded rods.
- Allows installer to easily brace existing trapeze supports.
- Includes: Bracket, B129 plate, & key. Hardware sold separately.
- Standard finish: ZN, GRN

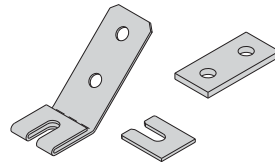

Part No. & Size	For Rod Size	TL		LL		Wt./C	
		Lbs.	kN	Lbs.	kN	Lbs.	kg
B650-3/8	3/8"	1100	(4.89)	1100	(4.89)	92	(41.4)
B650-1/2	1/2"	1500	(6.67)	1500	(6.67)	97	(43.6)
B650-5/8	5/8"	1500	(6.67)	1500	(6.67)	95	(42.7)
B650-3/4	3/4"	1500	(6.67)	1500	(6.67)	107	(48.5)

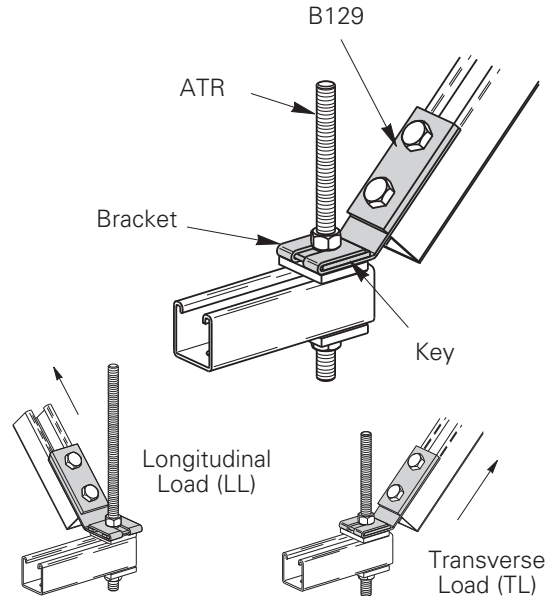

## B633 Adjustable Seismic Hinge Fitting

- Use 1/2" Bolt & Channel Nut on two hole side of Connector Fitting (Torque to 50 ft.-lbs.)
- Allows for swivel in two planes.
- Standard finish: ZN



Part No. & Size	A		B		Hole Size H		Wt./C	
	In.	mm	In.	mm	In.	mm	Lbs.	kg
B633-1/2	3 1/2"	(82.5)	1 5/8"	(41.3)	9/16"	(14.3)	92	(41.4)
B633-5/8	3 1/2"	(82.5)	1 5/8"	(41.3)	1 1/16"	(17.4)	97	(43.6)
B633-3/4	3 1/2"	(82.5)	1 5/8"	(41.3)	1 3/16"	(20.6)	95	(42.7)
B633-7/8	3 9/16"	(90.5)	2"	(50.8)	1 5/16"	(23.8)	107	(48.5)
B633-1	3 9/16"	(90.5)	2"	(50.8)	1 1/16"	(27.0)	120	(54.0)
B633-1 1/8	3 9/16"	(90.5)	2"	(50.8)	1 3/16"	(30.2)	104	(47.2)
B633-1 1/4	3 7/8"	(98.4)	2 1/4"	(57.1)	1 5/16"	(33.3)	114	(51.7)

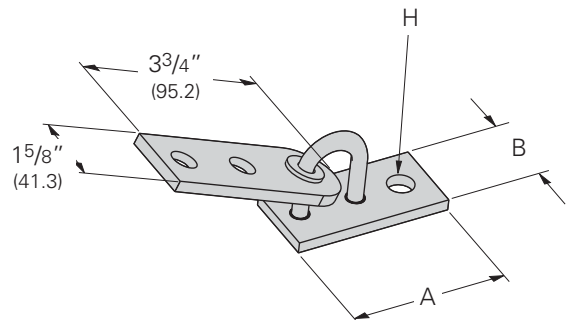

4Dimension compatible fitting

Reference page 106 for general fitting and standard finish specifications.

# Miscellaneous Seismic Fittings

**Fig. 75  
Swivel Attachment**

See page 89 for product information

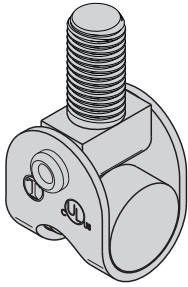

**SC228  
Hanger Rod Stiffener**

See page 91 for product information

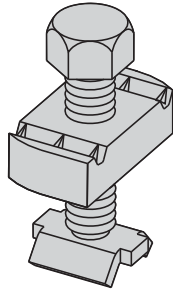

**Fig. 98  
Rod Stiffener**

See page 91 for product information

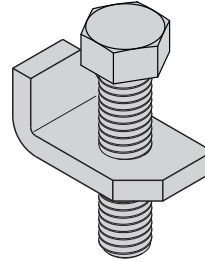

**Fig. 98B  
Rod Stiffener with  
Break-Off Bolt Head**

See page 91 for product information

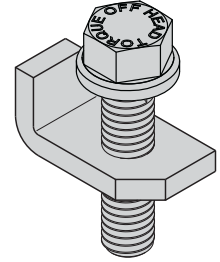

**Fig. 69  
Retaining Strap**

See page 156 for product information

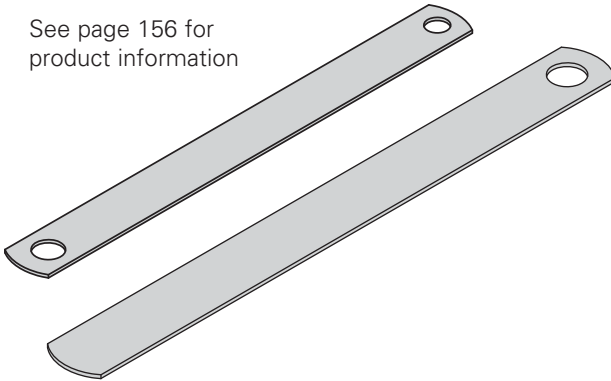

**Fig. 69R  
Retrofit Retaining Strap**

See page 156 for product information

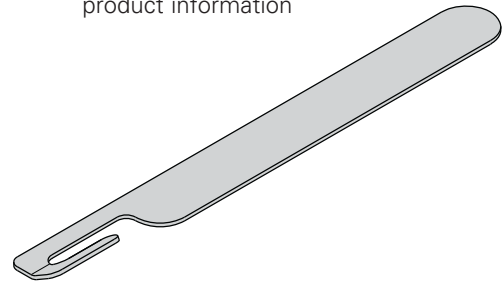

**Fig. 65  
Reversible Steel C-Type  
Beam Clamp - 3/4" (19.0mm)  
Throat Opening**

See page 157 for product information

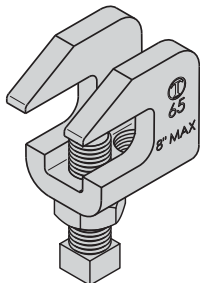

**Fig. 65XT  
Reversible C-Type  
Beam Clamp**

See page 157 for product information

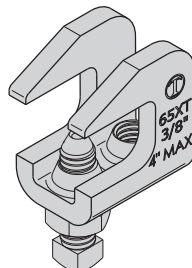

**Fig. 66  
Reversible Steel C-Type  
Beam Clamp - 1 1/4" (31.7mm)  
Throat Opening**

See page 157 for product information

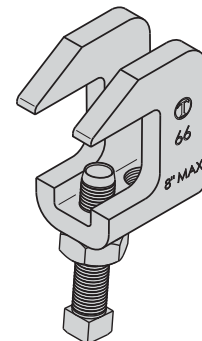

Reference page 106 for general fitting and standard finish specifications.

# Miscellaneous Seismic Fittings

## TOLCO™ Fig. 825 - Bar Joist Sway Brace Attachment

**Size Range:** One size accommodates all Fig. 900 Series sway brace attachments. Maximum Horizontal Design Load 2015 lbs (8.96kN).

**Material:** Steel

**Function:** To attach sway bracing and hanger assemblies to steel open web structural members.

**Features:** This product's design incorporates a concentric attachment point which is critical to the performance of structural seismic connections. NFPA 13 indicates the importance of concentric loading of connections and fasteners. Permits secure non-friction connection without drilling or welding. Unique design reinforces point of connection to joist. Break off head set screw design assures verification of proper installation torque (min. 31 ft.-lbs.).

**Approvals:** Underwriters Laboratories Listed in the USA (UL) and Canada (cUL). Approved by Factory Mutual Engineering (FM).

**Installation Instructions:** Fig. 825 is the structural attachment component of a longitudinal or lateral sway brace assembly. It is intended to be combined with a TOLCO transitional attachment, "bracing pipe" and a TOLCO "braced pipe" attachment, to form a complete bracing assembly. NFPA 13 and/or OSHPD guidelines should be followed.

**To Install:** Place the Fig. 825 on the steel beam, tighten the cone point set screws until heads break off. Attach other TOLCO transitional attachment fitting, Fig. 909, 910, 980 or 986. Transitional fitting attachment can pivot for adjustment to proper brace angle.

**Finish:** Plain, Electro-Galvanized and HDG

**Approx. Wt./100:** 247.5 Lbs. (112.2kg)

**Order By:** Figure number and finish  
US Patent #6,098,942,  
Canada Patent #2,286,659

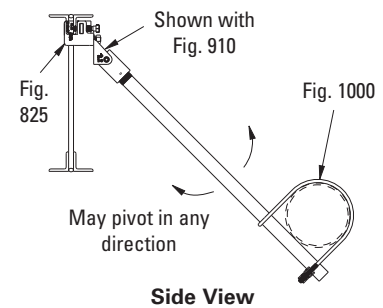
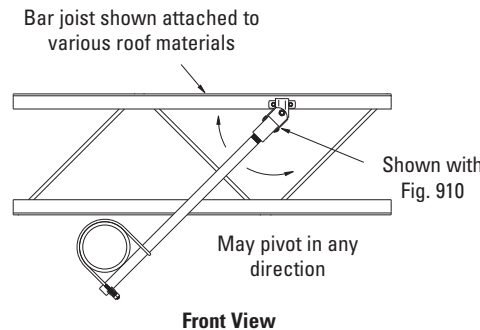
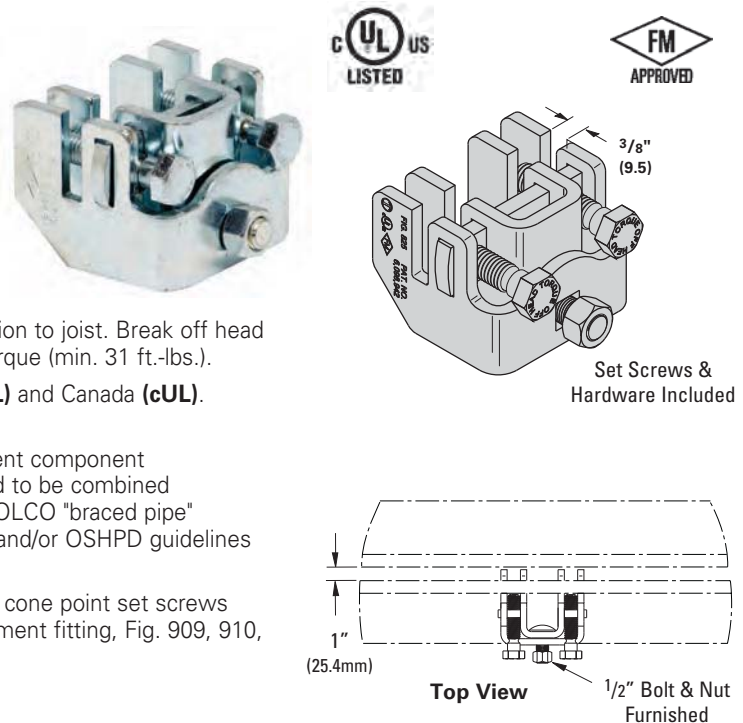

**Max. Horizontal Design Load (UL)**  
**2015 lbs. (8.96kN)**

**UL Listed as Hanger Attachment for**  
**6" (150mm) Pipe at Maximum Spacing**

		Max. Horizontal Design Loads (FM)			
		30°-44° lbs. / (kN)	45°-59° lbs. / (kN)	60°-74° lbs. / (kN)	75°-90° lbs. / (kN)
<b>Maximum</b>	<b>Perpendicular to</b>	990	1360	1670	1860
<b>3/8" Thick Flange</b>	<b>Structural Member</b>	(4.40)	(6.05)	(7.43)	(8.27)
<b>Maximum</b>	<b>Parallel to</b>	460	630	770	860
<b>3/8" Thick Flange</b>	<b>Structural Member</b>	(2.04)	(2.80)	(3.42)	(3.82)

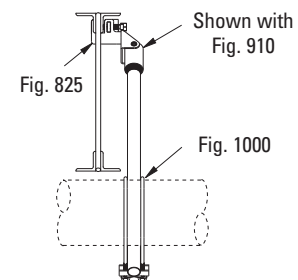

Eaton's B-Line series seismic bracing components are designed to be compatible only with other B-Line series bracing components, resulting in a listed seismic bracing assembly. Eaton B-Line Division warranty for seismic bracing components will be the warranty provided in Eaton B-Line Division standard terms and conditions of sale made available by Eaton, except that, in addition to the other exclusions from Eaton B-Line Division warranty, Eaton makes no warranty relating to B-Line series seismic bracing components that are combined with products not provided by Eaton.

Reference page 106 for general fitting and standard finish specifications.

## TOLCO™ Fig. 825A - Bar Joist Sway Brace Attachment

**Size Range:** One size accommodates all Fig. 900 Series sway brace attachments. Maximum Horizontal Design Load 1600 lbs (7.11kN).

**Material:** Steel

**Function:** To attach sway bracing to steel open web structural members.

**Features:** This product's design incorporates a concentric attachment point which is critical to the performance of structural seismic connections. NFPA 13 indicates the importance of concentric loading of connections and fasteners. Permits secure non-friction connection without drilling or welding. Unique design reinforces point of connection to joist. Break off head bolt design assures verification of proper installation.

**Approvals:** Underwriters Laboratories Listed in the USA (**UL**) and Canada (**cUL**). For additional load, spacing and placement information relating to OSHPD projects, please refer to the TOLCO Seismic Restraint Systems Guidelines.

**Installation Instructions:** Fig. 825A is the structural attachment component of a longitudinal or lateral sway brace assembly. It is intended to be combined with a TOLCO transitional attachment, "bracing pipe" and a TOLCO "braced pipe" attachment to form a complete bracing assembly. NFPA 13 and/or OSHPD guidelines should be followed.

**To Install:** Place the Fig. 825A on the steel beam, tighten the cone point set screws until heads break off. Attach other TOLCO transitional attachment fitting, Fig. 909, 910, 980 or 986. Transitional fitting attachment can pivot for adjustment to proper brace angle.

**Finish:** Plain or Electro-Galvanized

**Approx. Wt./100:** 154.5 Lbs. (70.1kg)

**Order By:** Figure number and finish  
Patent #6,098,942



Set Screws & Hardware Included

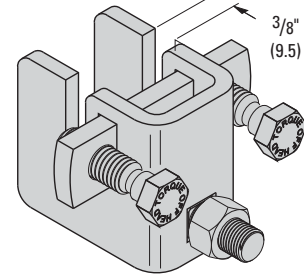

**Maximum Design Load  
1600 lbs.**



Bar joist shown attached to various roof materials

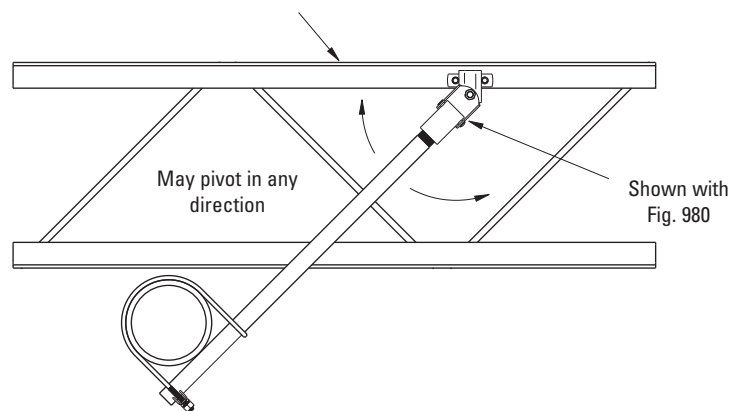

Eaton's B-Line series seismic bracing components are designed to be compatible only with other B-Line series bracing components, resulting in a listed seismic bracing assembly. Eaton B-Line Division warranty for seismic bracing components will be the warranty provided in Eaton B-Line Division standard terms and conditions of sale made available by Eaton, except that, in addition to the other exclusions from Eaton B-Line Division warranty, Eaton makes no warranty relating to B-Line series seismic bracing components that are combined with products not provided by Eaton.

Reference page 106 for general fitting and standard finish specifications.



# Miscellaneous Seismic Fittings

## TOLCO™ Fig. 828 - Universal Sway Brace Attachment

**Size Range:** One size accommodates all Fig. 900 Series sway brace attachments. Fits from 3/8" (9.4mm) to 7/8" (22.2mm) thick steel structure. For thicknesses less than 3/8" (9.4mm) refer to Fig. 825 and Fig. 825A.

**Material:** Steel

**Function:** To attach sway bracing to various types of steel structural members.

**Features:** Permits secure non-friction connection without drilling or welding. Unique design allows offset placement on wide flange beam, I-beam, C-channel, open web, welded steel trusses, etc.. Secures brace to structure either across or along the beam. Break-off set screws allow for visual verification of proper installation torque.

**Approvals:** Underwriters Laboratories Listed in the USA (UL) and Canada (cUL). Factory Mutual Approved (FM).

**Installation Instructions:** The Fig. 828 is the structural attachment component of a longitudinal or lateral sway brace assembly. It is intended to be combined with a TOLCO transitional attachment, "bracing pipe" and a TOLCO "braced pipe" attachment to form a complete bracing assembly. NFPA 13 and/or OSHPD guidelines should be followed.

**To Install:** Place the Fig. 828 on the flange of the beam, truss, or girder. Be sure the attachment is fully engaged to the rear of the opening. Tighten the cone point set screws (A) until the heads break off. Tighten the cone point set screw (B) until the head breaks off. Remove the flange nut from set screw (B). Install a TOLCO swivel fitting (Fig. 909, 910, 980, 986). Use flange nut to secure the swivel fitting.

**Finish:** Plain or Electro-Galvanized

**Approx. Weight/100:** 275 Lbs. (124.7kg)

**Order By:** Figure number and finish

Patent #6,098,942, #8,534,625

Canada Patent #2,286,659

**Patent Pending**

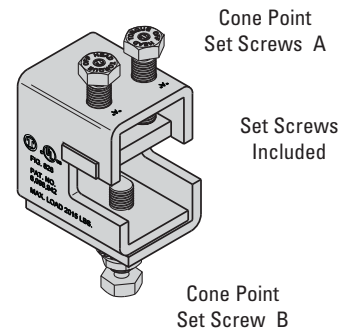

UL Horizontal Design Load	
<b>Maximum Design Load Across Beam</b>	
2015 lbs. (8.96kN)	
<b>Maximum Design Load Along Beam</b>	
2015 lbs. (8.96kN)	



Max. Horizontal Design Load (FM) With Brace Perpendicular To The Beam				
Brace Angle (degrees from vertical)				
30°-44°	45°-59°	60°-74°	75°-90°	
1570 (6.98kN)	2220 (9.87kN)	1210 (5.38kN)	700 (3.11kN)	

Max. Horizontal Design Load (FM) With Brace Parallel To The Beam				
Brace Angle (degrees from vertical)				
30°-44°	45°-59°	60°-74°	75°-90°	
690 (3.07kN)	970 (4.31kN)	1210 (5.38kN)	1330 (5.91kN)	

FM Approved design loads are based on ASD design method.

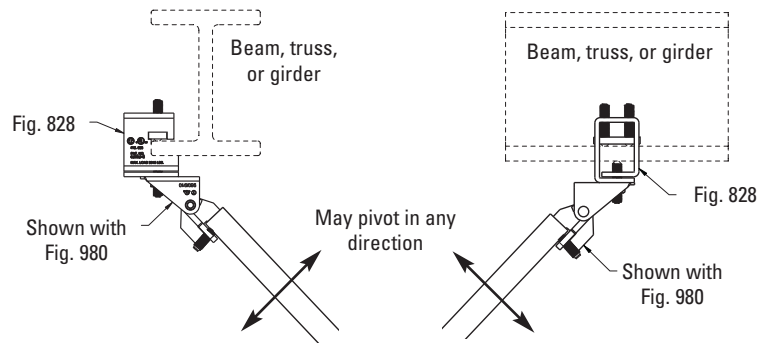

Eaton's B-Line series seismic bracing components are designed to be compatible only with other B-Line series bracing components, resulting in a listed seismic bracing assembly. Eaton B-Line Division warranty for seismic bracing components will be the warranty provided in Eaton B-Line Division standard terms and conditions of sale made available by Eaton, except that, in addition to the other exclusions from Eaton B-Line Division warranty, Eaton makes no warranty relating to B-Line series seismic bracing components that are combined with products not provided by Eaton.

## TOLCO™ Fig. 980 - Universal Swivel Sway Brace Attachment - 3/8"-16 to 3/4"-10 rods

## TOLCO™ Fig. 980H - Universal Swivel Sway Brace Attachment - 7/8"-9 to 1 1/4"-7 rods

**Size Range:** One size fits bracing pipe 1" (25mm) thru 2" (50mm), 12 gauge (2.6mm) channel, and all structural steel up to 1/4" (31.7mm) thick.

**Material:** Steel. Stainless Steel Type 316 (SS6) optional.

**Function:** Multi-functional attachment to structure or braced pipe fitting.

**Features:** This product's design incorporates a concentric attachment opening which is critical to the performance of structural seismic connections. NFPA 13 (2010) 9.3.5.8.4 indicates clearly that fastener table load values are based only on concentric loading. Mounts to any surface angle. Break off bolt head assures verification of proper installation.

**Installation:** Fig.980 is the structural or transitional attachment component of a longitudinal or lateral sway brace assembly. It is intended to be combined with the "bracing pipe" and TOLCO "braced pipe" attachment, Fig. 1000, 1001, 2002, 4L, 4A or 4B to form a complete bracing assembly. NFPA 13 and/or OSHPD guidelines should be followed.

**To Install:** Place the Fig. 980 onto the "bracing pipe". Tighten the set screw until the head breaks off. Attachment can pivot for adjustment to proper brace angle.

**Approvals:** —Underwriters Laboratories Listed in the USA (UL) and Canada (cUL). Approved by Factory Mutual Engineering (FM).

**Note:** Fig. 980 Swivel Attachment and Fig. 1001, Fig. 1000, Fig. 2002, Fig. 4A, Fig. 4B or Fig. 4L pipe clamps make up a sway brace system of UL Listed attachments and bracing materials which satisfies the requirements of Underwriters Laboratories and the National Fire Protection Association (NFPA)

**Finish:** Plain, Electro-Galvanized or Stainless Steel. Contact customer service for alternative finishes.

**Order By:** Figure number and finish.

### US Patent Numbers

Pat. #6,273,372, Pat. #6,517,030, Pat. #6,953,174,  
Pat. #6,708,930, Pat. #7,191,987, Pat. #7,441,730, Pat. #7,669,806

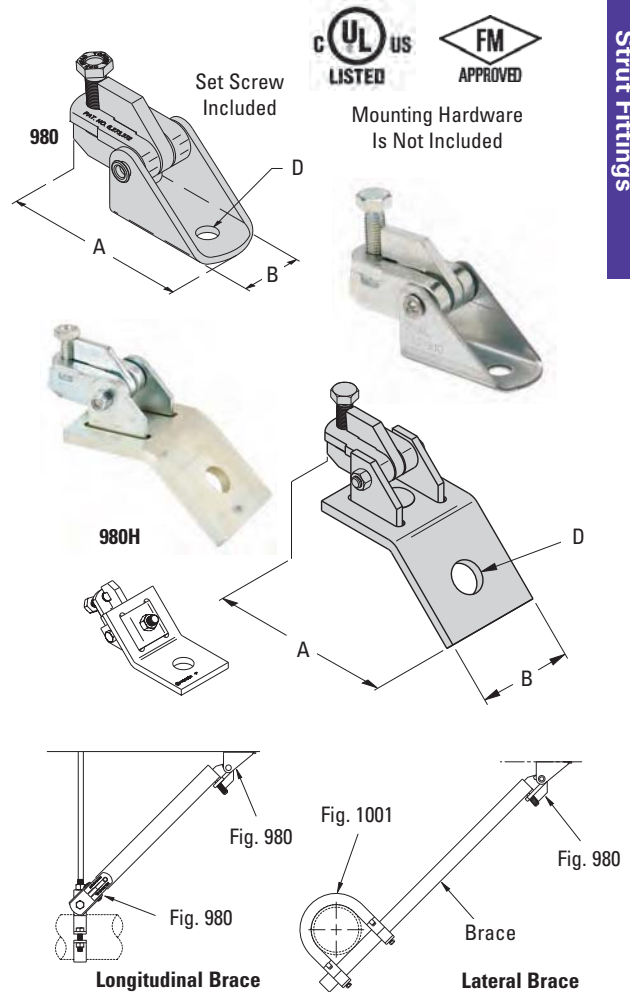

Part Number	Dimensions			Max. Horizontal Design Load (cULus) lbs./(kN)	Max. Horizontal Design Load** (FM)				Approx. Wt./100 lbs. (kg)
	A in. (mm)	B in. (mm)	D* in. (mm)		30°-44° lbs./(kN)	45°-59° lbs./(kN)	60°-74° lbs./(kN)	75°-90° lbs./(kN)	
980-3/8	5 1/4" (133.3)	1 7/8" (47.6)	1 3/32" (10.3)	2015 (8.96)	1320 (5.87)	1970 (8.76)	2310 (10.27)	2550 (11.34)	149 (67.6)
980-1/2	5 1/4" (133.3)	1 7/8" (47.6)	1 7/32" (13.5)						148 (67.1)
980-5/8	5 1/4" (133.3)	1 7/8" (47.6)	1 1/16" (17.5)						147 (66.7)
980-3/4	5 1/4" (133.3)	1 7/8" (47.6)	1 3/16" (20.5)						146 (66.2)
980H-7/8	6 3/4" (171.4)	3 1/2" (88.9)	1 5/16" (23.8)						402 (182.3)
980H-1	6 3/4" (171.4)	3 1/2" (88.9)	1 1/16" (27.0)						400 (181.4)
980H-1 1/8	6 3/4" (171.4)	3 1/2" (88.9)	1 3/16" (30.2)						397 (180.1)
980H-1 1/4	6 3/4" (171.4)	3 1/2" (88.9)	1 5/16" (33.3)						390 (176.9)

\* Mounting attachment hole size.

\*\* Installed with 1" or 1 1/4" Schedule 40 brace pipe.

**Important! - For load information when using Fig. 980 with pre-installed or post-installed concrete anchors in compliance with NFPA 13 (2016) or ASCE 7-10, including prying factors, see load tables on pages AL1 thru AL21.**

Eaton's B-Line series seismic bracing components are designed to be compatible only with other B-Line series bracing components, resulting in a listed seismic bracing assembly. Eaton B-Line Division warranty for seismic bracing components will be the warranty provided in Eaton B-Line Division standard terms and conditions of sale made available by Eaton, except that, in addition to the other exclusions from Eaton B-Line Division warranty, Eaton makes no warranty relating to B-Line series seismic bracing components that are combined with products not provided by Eaton.

Reference page 106 for general fitting and standard finish specifications.

# Miscellaneous Seismic Fittings

## TOLCO™ Fig. 981 - Fast Attach – Universal Swivel Sway Brace Attachment

**Size Range:** Fits bracing pipe 1" (25mm) thru 2" (50mm), 12 gauge (2.6mm) channel and all structural steel up to 1/4" (6.3mm) thick.

Fig. 981-S fits rod sizes 3/8" thru 5/8".

Fig. 981-L fits rod sizes 3/4" thru 7/8".

**Material:** Steel

**Function:** Multi-functional attachment to hanger rod, trapeze rod, structure or braced pipe fitting.

**Features:** Fits multiple sizes of bracing pipe, strut or structural steel. Swivel allows adjustment to various surface angles. Breakaway bolt heads assure verification of proper installation torque. Unique "fast attach" yoke design fits multiple rod sizes; 3/8" thru 5/8" and 3/4" thru 7/8". "Stackable" design allows installation of both lateral and longitudinal braces to be easily installed on a single hanger rod, with no disassembly.

**Installation:** Fig. 981 is the "braced pipe" attachment component of a lateral or longitudinal brace assembly. It is intended to be combined with the pipe hanger, all-thread rod, "bracing pipe" and TOLCO transitional and structural attachment component(s) to form a complete bracing assembly. NFPA 13 and or OSHPD guidelines should be followed.

**To Install:** Spin nut on top of hanger counterclockwise to loosen the nut and raise it above the top of the hanger. Attach Fig. 981 by slipping the open side of the 981 yoke onto the all thread rod above the top of the hanger. Tighten 3/8" cone point set screw on yoke until head breaks-off to ensure proper installation torque. Spin the hex nut clockwise and tighten securely. Insert brace pipe into the jaw of the 981 and tighten the cone point set screw until the head breaks off ensuring proper installation torque. Pivot brace pipe to proper angle and attach to structure using a TOLCO swivel structural attachment.

**Finish:** Electro-Galvanized

**Order By:** Figure number, rod size

**US Patent Numbers**

Pat. #6,273,372, Pat. #7,097,141, Pat. #7,654,043, Pat. #7,654,043 B2

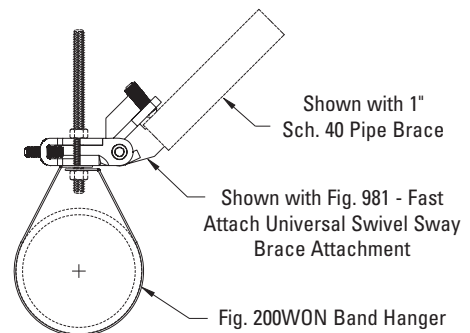
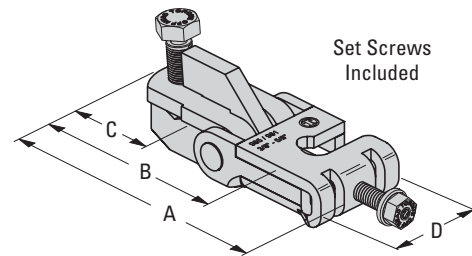

Part Number	Rod Size Range	A		B		C		D		Max. Horizontal Design Load lbs. (kN)	Approx. Wt./100 lbs. (kg)
		in.	(mm)	in.	(mm)	in.	(mm)	in.	(mm)		
981-S	3/8" thru 5/8"	5 1/8"	(130.2)	4 1/8"	(104.8)	1 1/4"	(31.7)	2 1/4"	(57.1)	2015 (8.96)	88 (39.9)
981-L	3/4" & 7/8"	5 1/8"	(130.2)	4 1/8"	(104.8)	1 1/4"	(31.7)	2 1/4"	(57.1)	2015 (8.96)	82 (37.2)

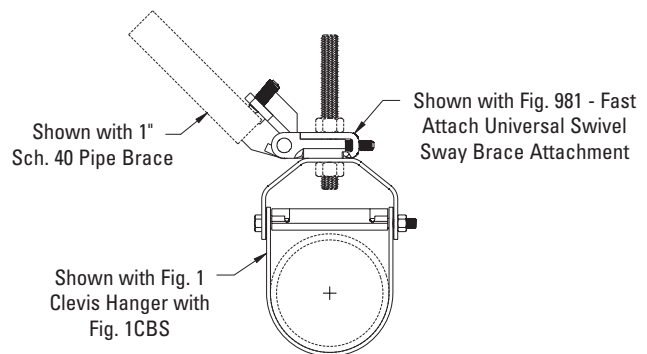
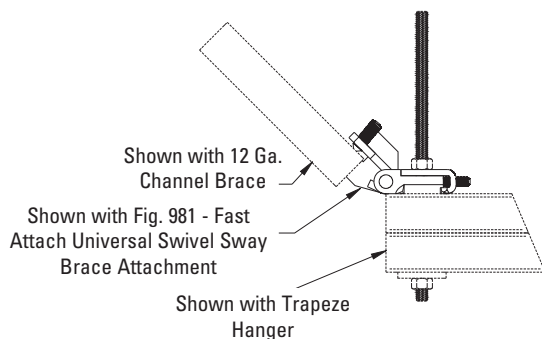

Reference page 106 for general fitting and standard finish specifications.

## TOLCO™ Fig. 985 - Mechanical Fast Clamp

**Size Range:** Fig. 985-S fits rod sizes  $\frac{3}{8}$ " thru  $\frac{5}{8}$ "  
 Fig. 985-L fits rod sizes  $\frac{3}{4}$ " thru  $\frac{7}{8}$ " rod sizes

**Material:** Steel

**Function:** Used for attachment of seismic bracing to pipe hanger or trapeze

**Features:** Allows up to 12" (304.8mm) of adjustability in brace length, when used with Fig. 986. Break-off set screw heads visually verify required installation torque. Unique "Fast Attach" yoke design allows Fig. 985 to be installed to hanger rods  $\frac{3}{8}$ " thru  $\frac{5}{8}$ " or  $\frac{3}{4}$ " thru  $\frac{7}{8}$ "

**Finish:** Electro-galvanized

**Order By:** Figure number, rod size & finish

**Patent Pending**

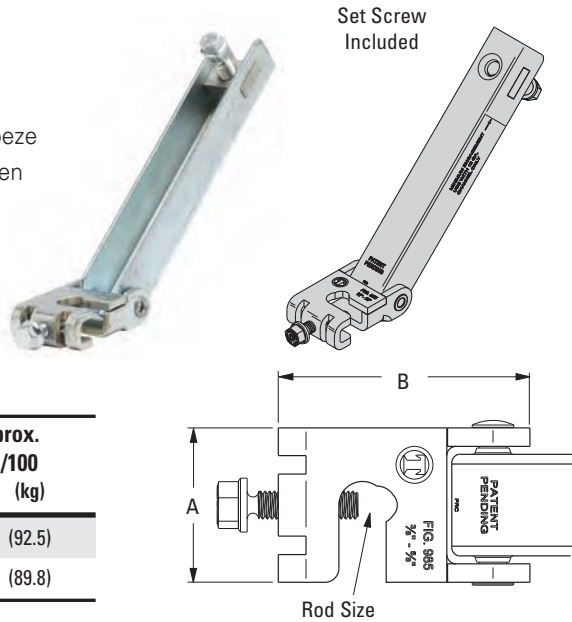

Part Number	Rod Size	A		B		Max. Horizontal Design Load lbs. (kN)	Approx. Wt./100 lbs. (kg)
		in.	(mm)	in.	(mm)		
985-S	$\frac{3}{8}$ " thru $\frac{5}{8}$ "	2"	(50.8)	1 1/2"	(38.1)	2015 (8.96)	204 (92.5)
985-L	$\frac{3}{4}$ " & $\frac{7}{8}$ "	2"	(50.8)	1 5/8"	(41.3)	2015 (8.96)	198 (89.8)

## TOLCO™ Fig. 986 - Mechanical Fast Clamp

**Size Range:** Available with holes for  $\frac{1}{2}$ "-13 thru  $\frac{3}{4}$ "-10 fastener attachment.

**Material:** Steel

**Function:** Used for attachment of seismic bracing to structure or hanger.

**Features:** Allows up to 12" (304.8mm) of adjustability in brace length, when used with Fig. 985. Break-off set screw heads visually verify required installation torque. Swivel allows adjustment to various surface angles.

**Finish:** Electro-galvanized

**Order By:** Figure number, rod size & finish

**Patent Pending**

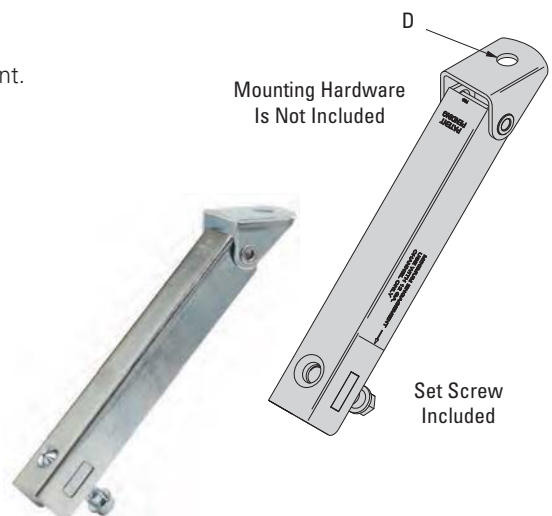

Part Number	Rod Size	Hole Dia. D		Max. Horizontal Design Load* lbs. (kN)	Approx. Wt./100 lbs. (kg)
		in.	(mm)		
986-1/2	$\frac{1}{2}$ "	9/16"	(14.3)	2015 (8.96)	204 (92.5)
986-5/8	$\frac{5}{8}$ "	11/16"	(17.5)	2015 (8.96)	203 (92.1)
986-3/4	$\frac{3}{4}$ "	13/16"	(20.6)	2015 (8.96)	202 (91.6)

\* When used with  $1\frac{5}{8}$ " (41.3mm) x  $1\frac{5}{8}$ " (41.3mm) 12 Ga. (2.6mm) channel

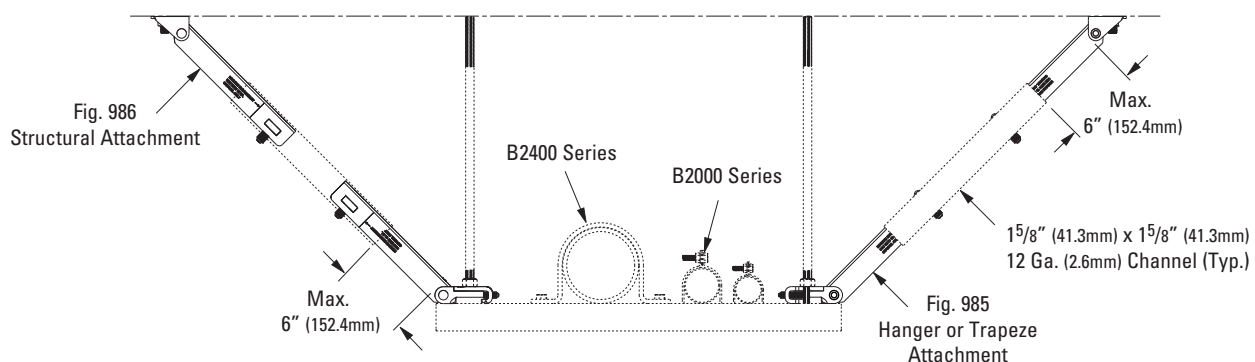

Reference page 106 for general fitting and standard finish specifications.

# Braces

## B261 - Two Hole 45° Knee Brace

- Standard finishes: ZN, GRN
- Design load determined by testing using a B335 hinged corner connection.
- Load ratings are for brace members only. Do not exceed allowable beam or column loads for strut channels.
- Safety Factor of 3



Part No.	A		B		Design Load		Wt./C	
	In.	mm	In.	mm	Lbs.	kN	Lbs.	kg
B261-8	8"	(203.2)	7 <sup>3</sup> / <sub>8</sub> "	(187.3)	1500	(6.67)	119	(54.0)
B261-12	12"	(304.8)	10 <sup>1</sup> / <sub>8</sub> "	(257.2)	1020	(4.54)	165	(74.8)
B261-16	16 <sup>5</sup> / <sub>8</sub> "	(422.3)	13 <sup>3</sup> / <sub>8</sub> "	(339.7)	530	(2.36)	218	(98.9)
B261-18	18"	(457.2)	14 <sup>7</sup> / <sub>16</sub> "	(366.7)	450	(2.00)	234	(106.1)
B261-24	24"	(609.6)	18 <sup>11</sup> / <sub>16</sub> "	(474.7)	250	(1.11)	303	(137.4)
B261-36	36"	(914.4)	27 <sup>3</sup> / <sub>16</sub> "	(690.6)	110	(.49)	441	(200.0)

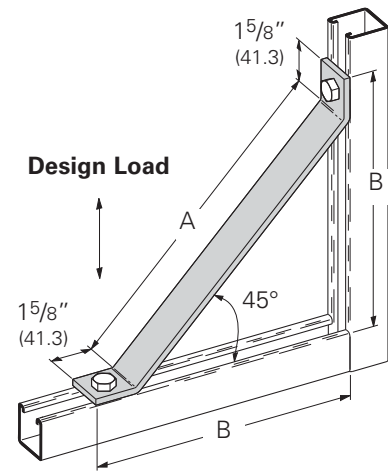

## B631 - Two Hole 45° Tubing Knee Brace

- 1" (25.4) Square steel tubing
- Material: ASTM A513
- Standard finishes: ZN, GRN
- Design load determined by testing using a B335 hinged corner connection.
- Load ratings are for brace members only. Do not exceed allowable beam or column loads for strut channels.
- Safety Factor of 3



Part No.	A		Design Load		Wt./C	
	In.	mm	Lbs.	kN	Lbs.	kg
B631-18	18"	(457.2)	1500	(6.67)	145	(65.8)
B631-24	24"	(609.6)	1500	(6.67)	186	(84.4)
B631-30	30"	(762.0)	1500	(6.67)	225	(102.0)
B631-36	36"	(914.4)	1500	(6.67)	266	(120.6)
B631-42	42"	(1066.8)	1230	(5.47)	307	(139.2)
B631-48	48"	(1219.2)	940	(4.18)	348	(157.8)
B631-54	54"	(1371.6)	740	(3.29)	389	(176.4)
B631-60	60"	(1524.0)	600	(2.67)	430	(195.0)
B631-72	72"	(1828.8)	420	(1.87)	508	(230.4)
B631-84	84"	(2133.6)	310	(1.38)	589	(267.2)
B631-96	96"	(2438.4)	240	(1.07)	669	(303.5)

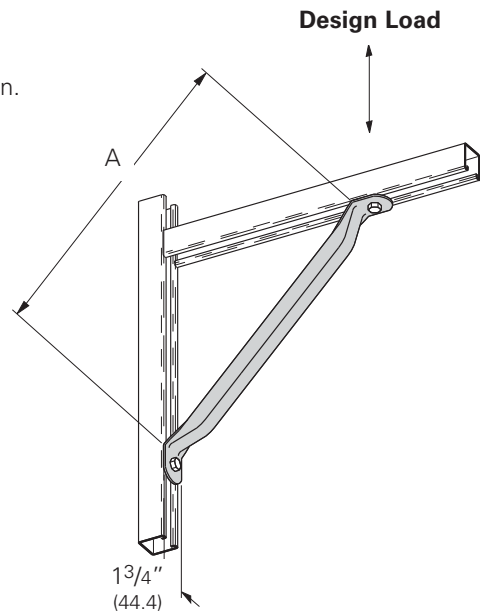

## B632 - Two Hole Straight Tubing Brace

- 1" (25.4) Square steel tubing
- Material: ASTM A513
- Standard finishes: ZN, GRN



Part No.	A		Wt./C	
	In.	mm	Lbs.	kg
B632-18	18"	(457.2)	133	(60.3)
B632-24	24"	(609.6)	174	(78.9)
B632-30	30"	(762.0)	215	(97.5)
B632-36	36"	(914.4)	256	(116.1)
B632-42	42"	(1066.8)	295	(133.8)
B632-48	48"	(1219.2)	335	(151.9)
B632-54	54"	(1371.6)	380	(172.3)
B632-60	60"	(1524.0)	420	(190.5)
B632-72	72"	(1828.8)	500	(226.8)
B632-84	84"	(2133.6)	585	(265.3)
B632-96	96"	(2438.4)	670	(303.9)

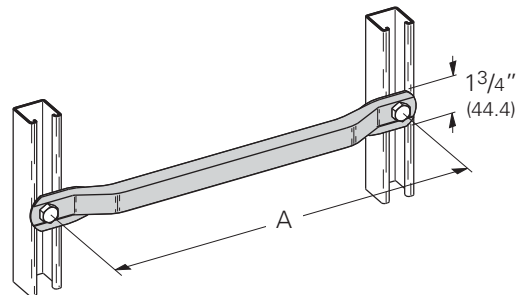

4Dimension compatible fitting

Reference page 106 for general fitting and standard finish specifications.

**B169**  
**Two Hole Splice**  
**Clevis For B52**

- Standard finishes: ZN, GRN
- Wt./C 84 Lbs. (38.1 kg)

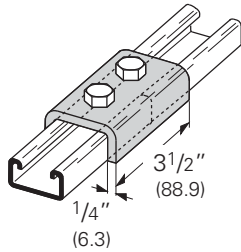

**B168**  
**Three Hole Splice**  
**Clevis For B52**

- Standard finishes: ZN, GRN
- Wt./C 126 Lbs. (57.1 kg)

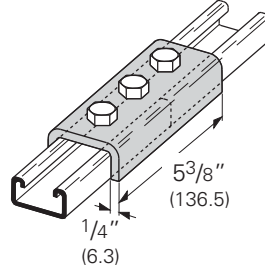

**B167**  
**Four Hole Splice**  
**Clevis For B52**

- Standard finishes: ZN, GRN
- Wt./C 178 Lbs. (80.7 kg)

PA GRN

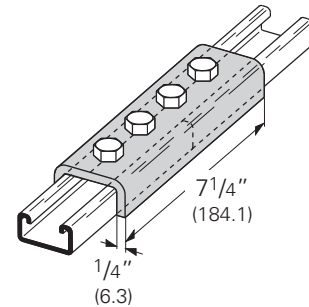

**B170**  
**Two Hole Splice**  
**Clevis For B22 or B52A**

- Standard finishes: ZN, GRN
- Wt./C 123 Lbs. (55.8 kg)

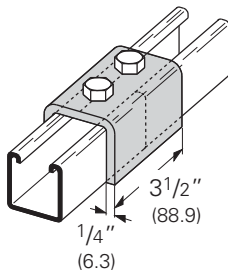

**B171**  
**Three Hole Splice**  
**Clevis For B22 or B52A**

- Standard finishes: ZN, GRN
- Wt./C 195 Lbs. (88.4 kg)

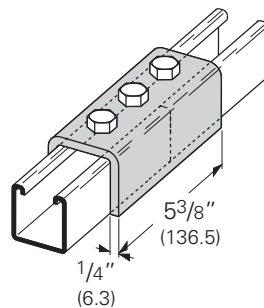

**B172**  
**Four Hole Splice**  
**Clevis For B22 or B52A**

- Standard finishes: ZN, GRN
- Wt./C 266 Lbs. (120.6 kg)

PA ZN  
GRN

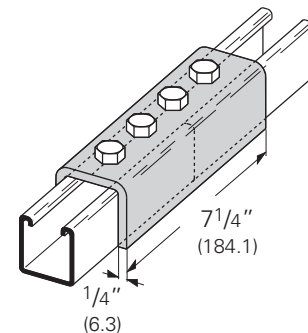

**B172-12**  
**Four Hole Splice Clevis For B12**

- Standard finishes: ZN, GRN
- Wt./C 326 Lbs. (147.8 kg)

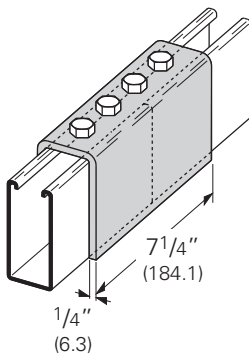

**B172-22A**  
**Four Hole Splice**  
**Clevis For B11 or B22A**

- Standard finishes: ZN, GRN
- Wt./C 406 Lbs. (184.1 kg)

PA GRN

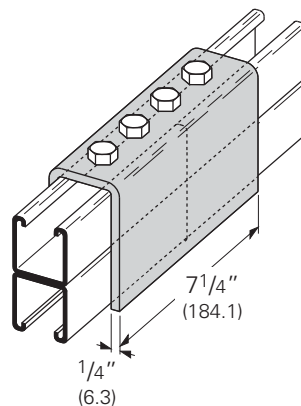

**B450**  
**U-Washer**

- Material: ASTM A1011 HSLAS Gr. 50
- Standard finishes: ZN, GRN

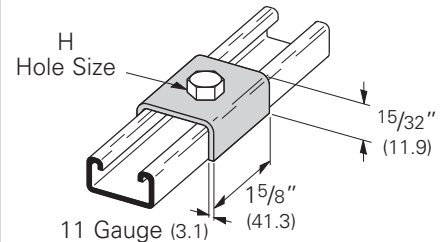

Part No. & Size	Hole Size H	Wt./C
	Lbs. kg	Lbs. kg
B450-1/4	5/16" (7.9)	14 (6.3)
B450-3/8	7/16" (11.1)	14 (6.3)
B450-1/2	9/16" (14.3)	13 (5.8)
B450-5/8	11/16" (17.4)	13 (5.8)
B450-3/4	13/16" (20.6)	13 (5.8)

PA Pre-assembled fitting.

Reference page 106 for general fitting and standard finish specifications.

# 'U' Fittings

## B527 Three Hole Offset Plate Connection

- Standard finishes: ZN, GRN
- Wt./C 54 Lbs. (24.5 kg)

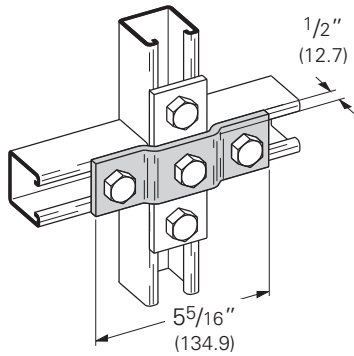

## B116-52 Three Hole U-Support

- Standard finishes: ZN, GRN
- Wt./C 70 Lbs. (31.7 kg)

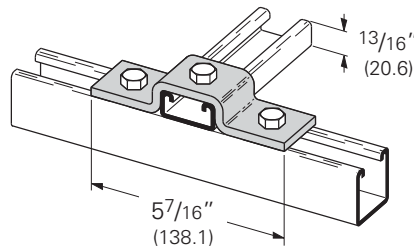

## B116-42 Three Hole U-Support

- Standard finishes: ZN, GRN
- Wt./C 75 Lbs. (34.0 kg)

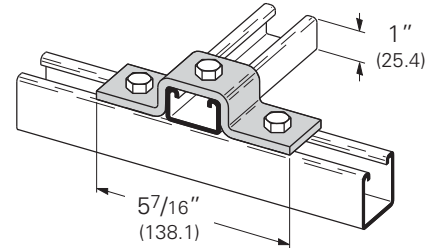

## B116-32 Three Hole U-Support

- Standard finishes: ZN, GRN
- Wt./C 84 Lbs. (38.1 kg)

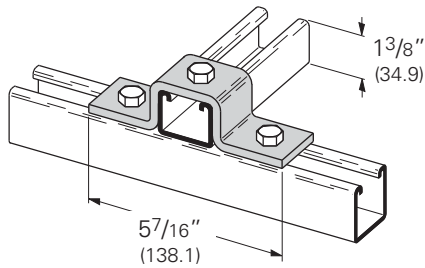

## B116-32A Three Hole U-Support

- Standard finishes: ZN, GRN
- Wt./C 116 Lbs. (52.6 kg)

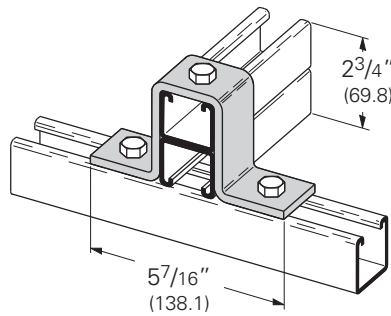

## B116-12 Three Hole U-Support

- Standard finishes: ZN, GRN
- Wt./C 108 Lbs. (49.0 kg)

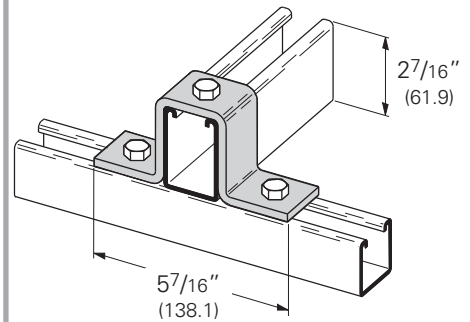

## B107 Five Hole U-Support

- Standard finishes: ZN, GRN, HDG
- Wt./C 85 Lbs. (38.5 kg)

PA <sup>ZN</sup>  
GRN

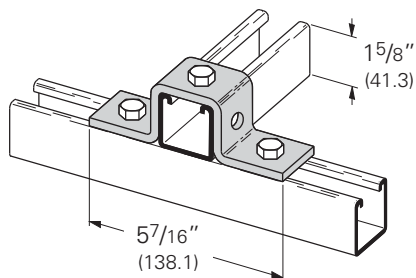

## B107-22A Three Hole U-Support

- Standard finishes: ZN, GRN
- Wt./C 126 Lbs. (57.1 kg)

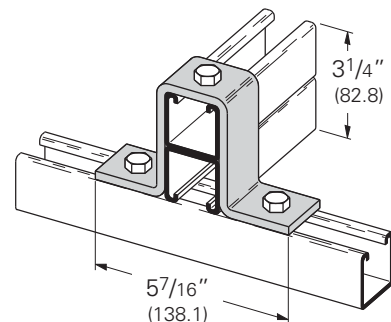

## B588 Three Hole U-Support

- Standard finishes: ZN, GRN
- Wt./C 157 Lbs. (71.2 kg)

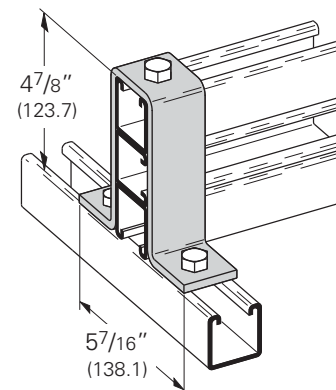

PA Pre-assembled fitting.

Reference page 106 for general fitting and standard finish specifications.

**B412**  
**Three Hole**  
**Offset U-Support**

- Standard finishes: ZN, GRN
- Wt./C 89 Lbs. (40.3 kg)

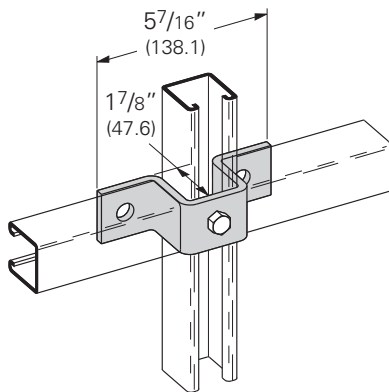

**B107S**  
**Five Hole U-Support**

- Material: 7 Gauge (4.5)  
ASTM A1011 33,000 PSI min. yield
- Standard finishes: ZN, GRN
- Wt./C 51 Lbs. (23.1 kg)

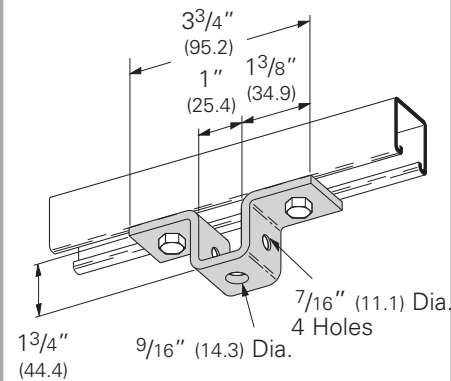

**B596**  
**Three Hole Swivel Clevis**

- Material: 7 Gauge (4.5)
- Standard finishes: ZN, GRN
- Wt./C 53 Lbs. (24.0 kg)

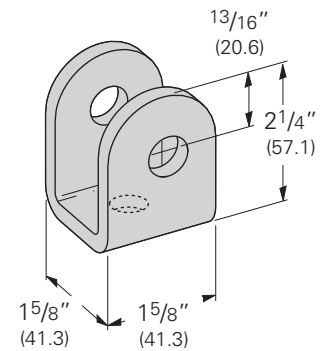

**B578**  
**Three Hole Light-Weight**  
**U-Support**

- Material: 10 Gauge (3.4)  
ASTM A1011 HSLAS Gr. 50
- Standard finishes: ZN, GRN
- Wt./C 18 Lbs. (8.1 kg)

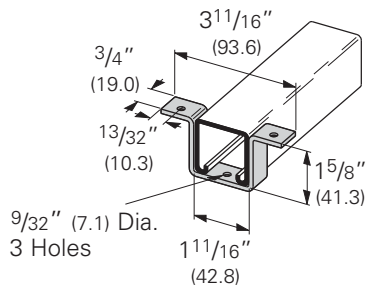

**B594**  
**Five Hole U-Support**

- Standard finishes: ZN, GRN
- Wt./C 106 Lbs. (48.1 kg)

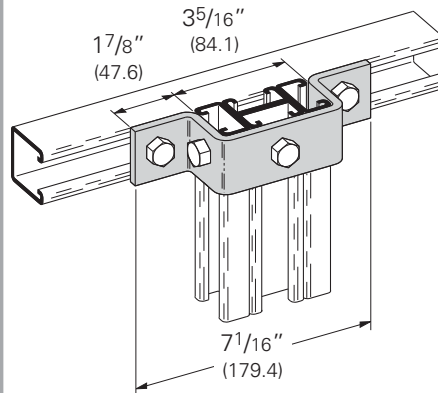

**B266**  
**Six Hole U-Support**

- Standard finishes: ZN, GRN
- Wt./C 105 Lbs. (47.6 kg)

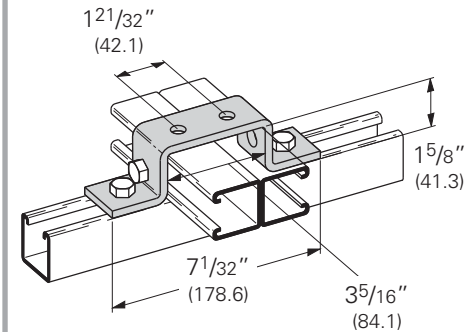

**B425**  
**Six Hole U-Support**

- Standard finishes: ZN, GRN
- Wt./C 167 Lbs. (75.7 kg)

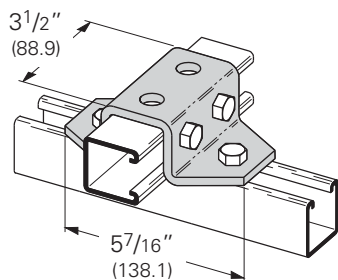

**B581**  
**Eight Hole U-Support**

- Standard finishes: ZN, GRN
- Wt./C 201 Lbs. (91.2 kg)

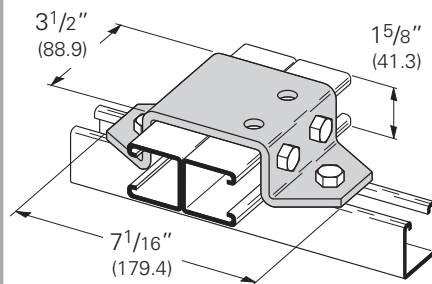

**B519**  
**Eight Hole U-Support**

- Standard finishes: ZN, GRN
- Wt./C 266 Lbs. (102.5 kg)

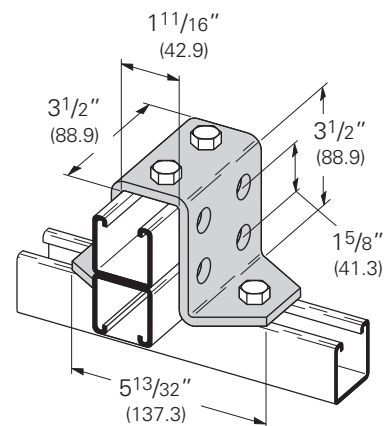

Reference page 106 for general fitting and standard finish specifications.



# 'U' Fittings

## B333 Slotted Three Hole U-Support For B22

- Standard finishes: ZN, GRN

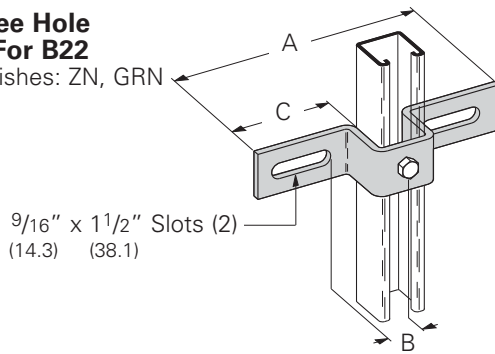

Part No.	A		B		C		Wt./C	
	In.	mm	In.	mm	In.	mm	Lbs.	kg
B333-1	7 1/2"	(190.5)	1 5/16"	(33.3)	2 7/8"	(73.0)	103	(46.7)
B333-2	8 1/2"	(215.9)	1 15/16"	(49.2)	3 3/8"	(85.7)	115	(52.1)
B333-3	10 3/8"	(263.5)	2 7/8"	(73.0)	4 5/16"	(109.5)	135	(61.2)

## B451 Slotted Three Hole U-Support With Gusset For B22

- Consists of B333-1, 2, or 3 with gusset plate welded on back.
- Material: ASTM A1011 HSLAS Gr. 50
- Standard finishes: ZN, GRN

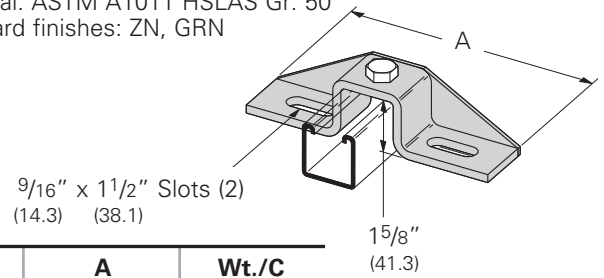

Part No.	A		Wt./C	
	In.	mm	Lbs.	kg
B451-1	7 1/2"	(190.5)	137	(62.1)
B451-2	8 1/2"	(215.9)	156	(70.7)
B451-3	10 3/8"	(263.5)	172	(78.0)

## B408 Two Hole Bus Duct Clevis

- Standard finishes: ZN, GRN

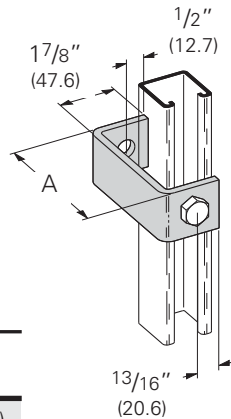

Part No.	A		Wt./C	
	In.	mm	Lbs.	kg
B408-1	2 13/32"	(61.1)	58	(26.3)
B408-2	3 25/32"	(96.0)	76	(34.5)
B408-3	4 3/4"	(762.0)	88	(39.9)

## B358 Two Hole Clevis

- Standard finishes: ZN, GRN

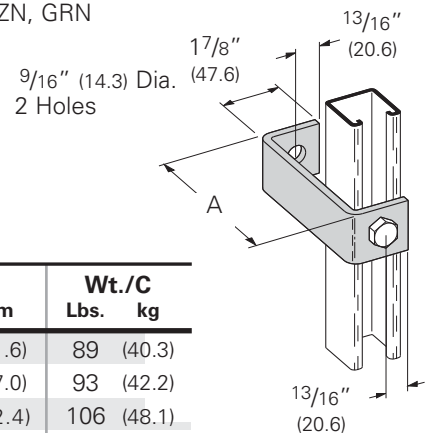

Part No.	A		Wt./C	
	In.	mm	Lbs.	kg
B358-4	4"	(101.6)	89	(40.3)
B358-5	5"	(127.0)	93	(42.2)
B358-6	6"	(152.4)	106	(48.1)
B358-7	7"	(177.8)	118	(53.5)
B358-8	8"	(203.2)	132	(59.9)

## B173 Four Hole Clevis

- Standard finishes: ZN, GRN
- Wt./C 71 Lbs. (32.2 kg)

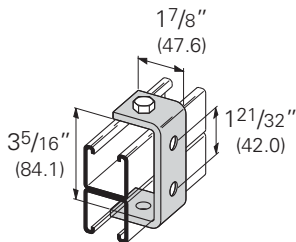

## B595 Three Hole Clevis

- Standard finishes: ZN, GRN
- Wt./C 75 Lbs. (34.0 kg)

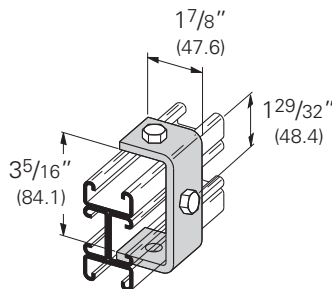

## B405 Three Hole Suspension Clevis

- Standard finishes: ZN, GRN
- Wt./C 75 Lbs. (34.0 kg)

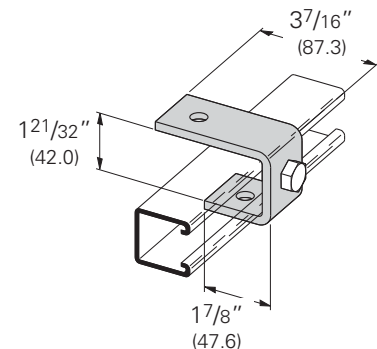

Reference page 106 for general fitting and standard finish specifications.

## B398-1 Three Hole Cup Support

- Standard finishes: ZN, GRN
- Wt./C 73 Lbs. (33.1 kg)

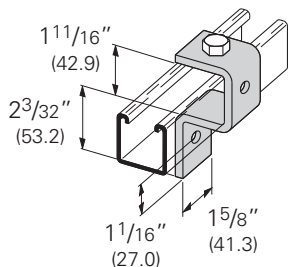

## B400 Three Stud Ring Connection

- 1/2"-13 stud protrudes 1" (25.4mm)
- Standard finishes: ZN
- Wt./C 85 Lbs. (38.5 kg)

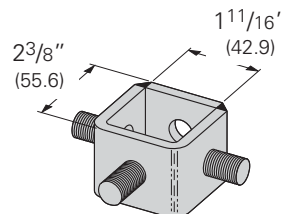

## B400-1 One Stud Ring Connection

- 1/2"-13 stud protrudes 1" (25.4mm)
- Standard finishes: ZN
- Wt./C 53 Lbs. (24.0 kg)

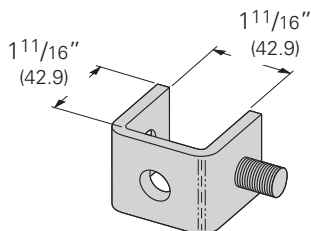

## B400-2 One Stud Ring Connection

- 1/2"-13 stud protrudes 1" (25.4mm)
- Standard finishes: ZN
- Wt./C 40 Lbs. (18.1 kg)

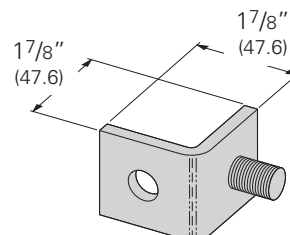

## B400-3 Two Stud Ring Connection

- 1/2"-13 stud protrudes 1" (25.4mm)
- Standard finishes: ZN
- Wt./C 59 Lbs. (26.7 kg)

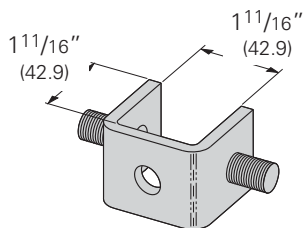

## B400-4 Two Stud Ring Connection

- 1/2"-13 stud protrudes 1" (25.4mm)
- Standard finishes: ZN
- Wt./C 59 Lbs. (26.7 kg)

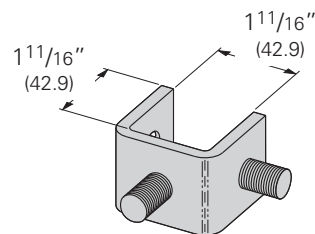

Reference page 106 for general fitting and standard finish specifications.

# 'Z' Fittings

## B526 Two Hole Offset Z-Support

- Standard finishes: ZN, GRN
- Wt./C 38 Lbs. (17.2 kg)

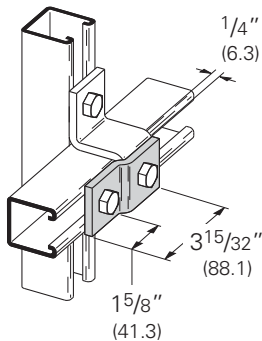

## B106-52 Two Hole Offset Z-Support for B52

- Standard finishes: ZN, GRN
- Wt./C 40 Lbs. (18.1 kg)

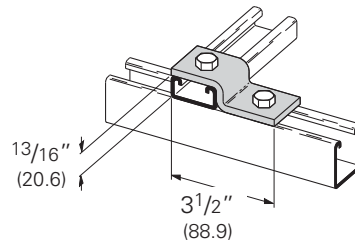

## B106-42 Two Hole Offset Z-Support for B42

- Standard finishes: ZN, GRN
- Wt./C 44 Lbs. (20.0 kg)

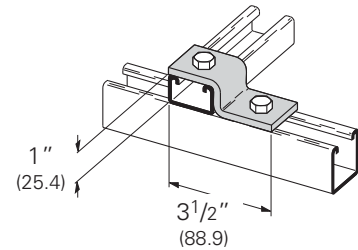

## B106-32 Two Hole Offset Z-Support for B32

- Standard finishes: ZN, GRN
- Wt./C 51 Lbs. (23.1 kg)

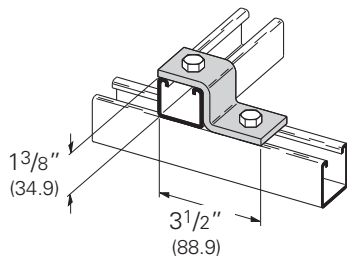

## B106-12 Two Hole Offset Z-Support for B12

- Standard finishes: ZN, GRN
- Wt./C 63 Lbs. (28.6 kg)

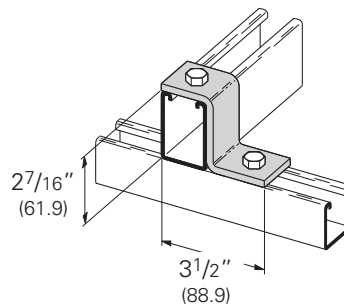

## B105 Three Hole Offset Z-Support for B22

- Standard finishes: ZN, GRN, HDG
- Wt./C 51 Lbs. (23.1 kg)

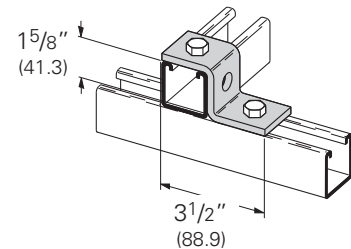

## B110 Three Hole Offset Z-Support for B11

- Standard finishes: ZN, GRN
- Wt./C 70 Lbs. (31.7 kg)

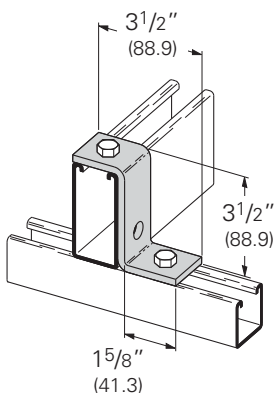

## B586 Two Hole Z-Support

- Standard finishes: ZN, GRN
- Wt./C 90 Lbs. (40.8 kg)

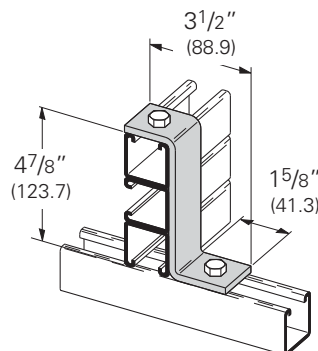

## B108 Two Hole Offset Z-Support

- Standard finishes: ZN, GRN
- Wt./C 55 Lbs. (24.9 kg)

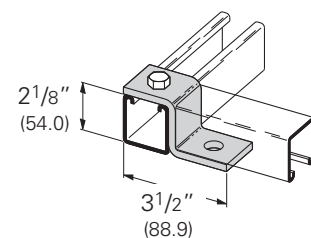

Reference page 106 for general fitting and standard finish specifications.

## B387 Two Hole Z-Bus Duct Connection

- Standard finishes: ZN, GRN

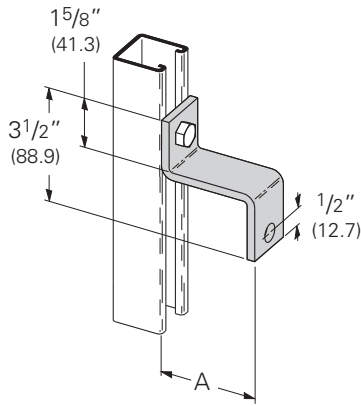

Part No.	A		Wt./C	
	In.	mm	Lbs.	kg
<b>B387</b>	4 <sup>3</sup> / <sub>4</sub> "	(120.6)	89	(40.3)
<b>B387-1</b>	3 <sup>25</sup> / <sub>32</sub> "	(96.0)	78	(35.4)
<b>B387-2</b>	2 <sup>13</sup> / <sub>32</sub> "	(61.1)	62	(28.1)

## B407 Two Hole Z-Support

- Standard finishes: ZN, GRN

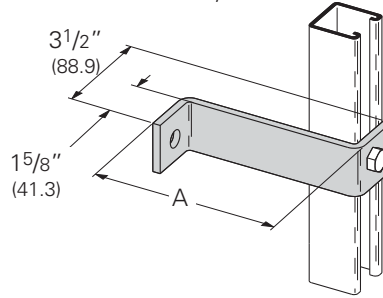

Part No.	A		Wt./C	
	In.	mm	Lbs.	kg
<b>B407-4</b>	4"	(101.6)	77	(34.9)
<b>B407-5</b>	5"	(127.0)	95	(43.1)
<b>B407-6</b>	6"	(152.4)	98	(44.4)
<b>B407-7</b>	7"	(177.8)	105	(47.6)
<b>B407-8</b>	8"	(203.2)	120	(54.4)
<b>B407-9<sup>5</sup>/<sub>8</sub></b>	9 <sup>5</sup> / <sub>8</sub> "	(244.5)	138	(62.6)

## B111 Three Hole Sheath Corner Connection

- Standard finishes: ZN, GRN
- Wt./C 68 Lbs. (30.8 kg)

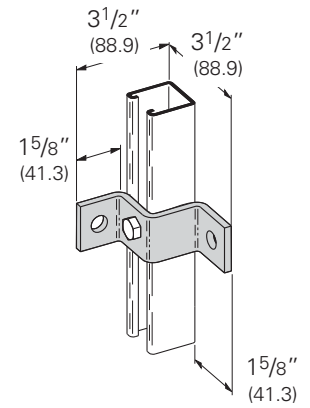

## B410-52 Channel Hanger Bracket for B52

- Material: 11 Gauge (3.0)  
ASTM A1011 HSLAS Gr. 50
- Standard finishes: ZN, GRN
- Wt./C 6.7 Lbs. (3.0 kg)

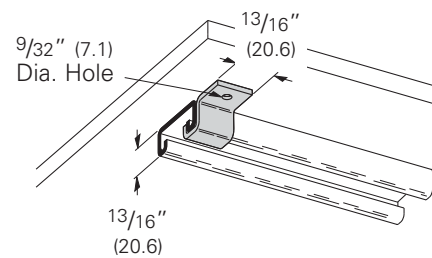

## B410-32 Channel Hanger Bracket for B32

- Material: 11 Gauge (3.0)  
ASTM A1011 HSLAS Gr. 50
- Standard finishes: ZN, GRN
- Wt./C 8.3 Lbs. (3.7 kg)

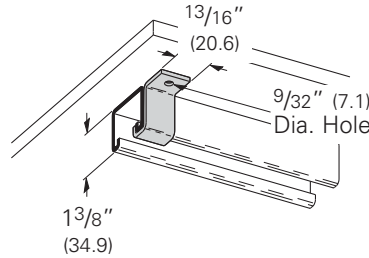

## B410-22 Channel Hanger Bracket for B22

- Material: 11 Gauge (3.0)  
ASTM A1011 HSLAS Gr. 50
- Standard finishes: ZN, GRN
- Wt./C 9 Lbs. (4.1 kg)

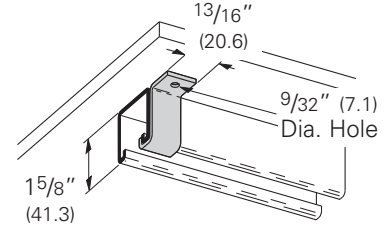

## B410-12 Channel Hanger Bracket for B12

- Material: 11 Gauge (3.0)  
ASTM A1011 HSLAS Gr. 50
- Standard finishes: ZN, GRN
- Wt./C 11.2 Lbs. (5.1 kg)

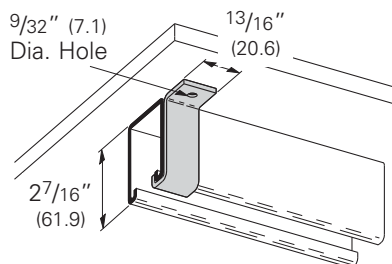

## B410-11 Channel Hanger Bracket for B11

- Material: 11 Gauge (3.0)  
ASTM A1011 HSLAS Gr. 50
- Standard finishes: ZN, GRN
- Wt./C 13.4 Lbs. (6.1 kg)

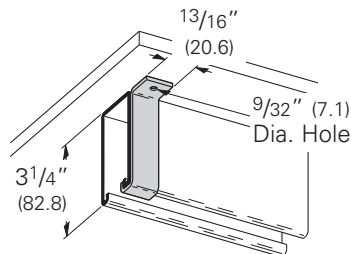

## B580 Five Hole Gussetted Z-Support

- Standard finishes: ZN, GRN
- Wt./C 100 Lbs. (45.3 kg)

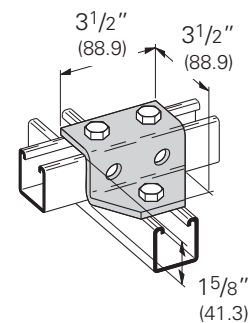

Reference page 106 for general fitting and standard finish specifications.

# 'Z' & Wing Fittings

## B515 Adjustable Offset Gusseted Z-Support

- Standard finishes: ZN, GRN
- Wt./C 93 Lbs. (42.2 kg)

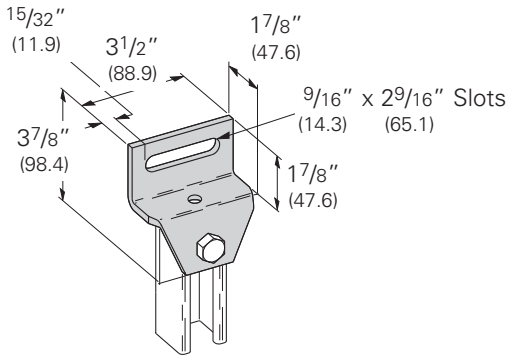

## B428 Eight Hole Gusseted Corner Connection

- Standard finishes: ZN, GRN
- Wt./C 203 Lbs. (92.1 kg)

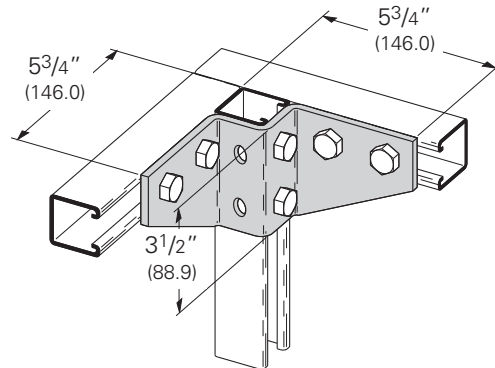

## B267R Three Hole Single Corner Connection (Right Hand)

- Standard finishes: ZN, GRN
- Wt./C 54 Lbs. (24.5 kg)

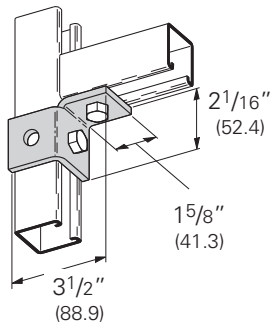

## B267L Three Hole Single Corner Connection (Left Hand)

- Standard finishes: ZN, GRN
- Wt./C 54 Lbs. (24.5 kg)

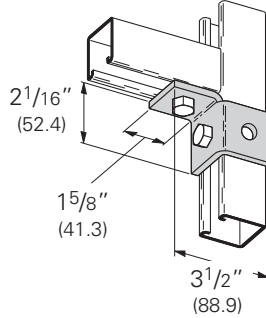

## B270R Four Hole Single Corner Connection (Right Hand)

- Standard finishes: ZN, GRN
- Wt./C 77 Lbs. (34.9 kg)

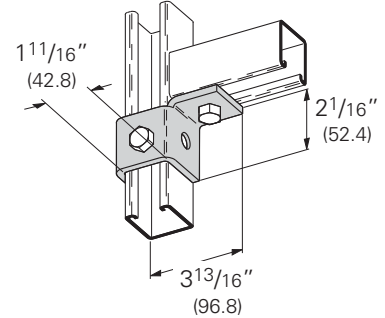

## B270L Four Hole Single Corner Connection (Left Hand)

- Standard finishes: ZN, GRN
- Wt./C 77 Lbs. (34.9 kg)

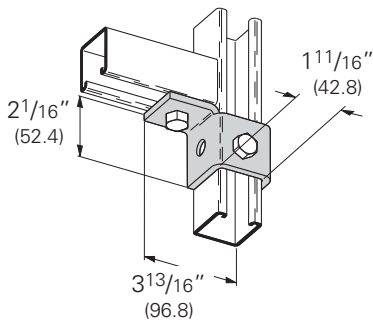

## B268R Five Hole Single Corner Connection (Right Hand)

- Standard finishes: ZN, GRN
- Wt./C 100 Lbs. (45.3 kg)

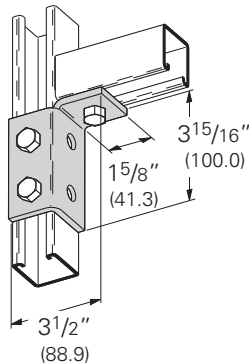

## B268L Five Hole Single Corner Connection (Left Hand)

- Standard finishes: ZN, GRN
- Wt./C 100 Lbs. (45.3 kg)

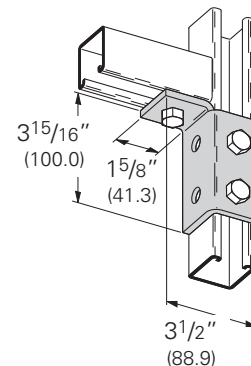

Reference page 106 for general fitting and standard finish specifications.

**B269R**  
**Six Hole Single Corner Connection (Right Hand)**

- Standard finishes: ZN, GRN
- Wt./C 120 Lbs. (54.4 kg)

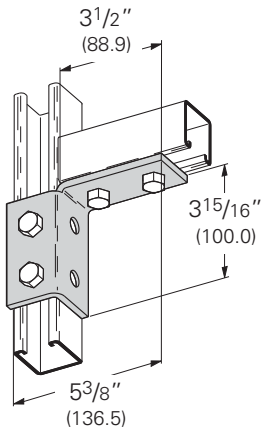

**B269L**  
**Six Hole Single Corner Connection (Left Hand)**

- Standard finishes: ZN, GRN
- Wt./C 120 Lbs. (54.4 kg)

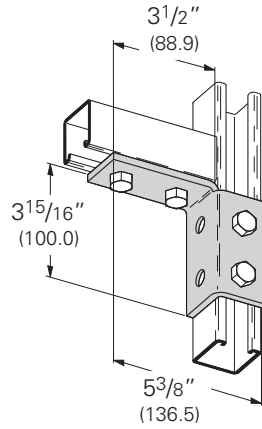

**B119**  
**Six Hole Double Corner Connection**

- Standard finishes: ZN, GRN
- Wt./C 71 Lbs. (32.2 kg)

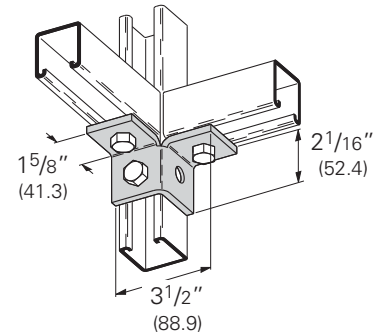

**B120**  
**Six Hole Double Corner Connection**

- Standard finishes: ZN, GRN
- Wt./C 110 Lbs. (49.9 kg)

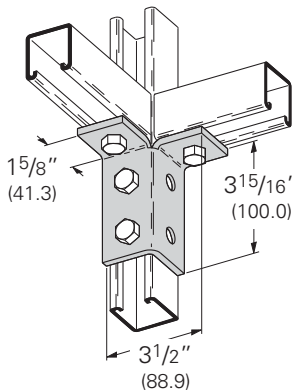

**B121**  
**Eight Hole Double Corner Connection**

- Standard finishes: ZN, GRN
- Wt./C 152 Lbs. (68.9 kg)

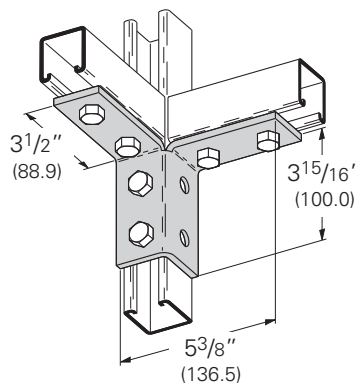

**B271**  
**Five Hole Double Wing Connection**

- Standard finishes: ZN, GRN
- Wt./C 95 Lbs. (43.1 kg)

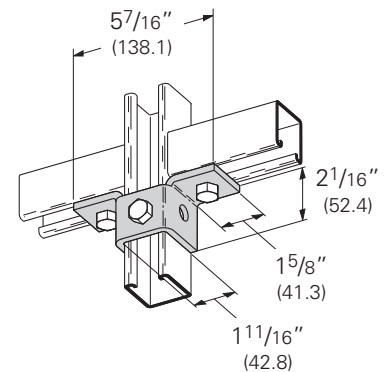

**B272**  
**Eight Hole Double Wing Connection**

- Standard finishes: ZN, GRN
- Wt./C 156 Lbs. (70.7 kg)

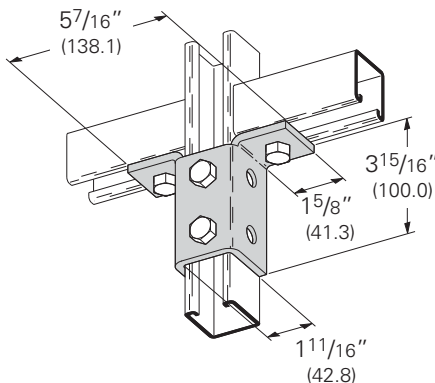

**B273**  
**Ten Hole Double Wing Connection**

- Standard finishes: ZN, GRN
- Wt./C 185 Lbs. (83.9 kg)

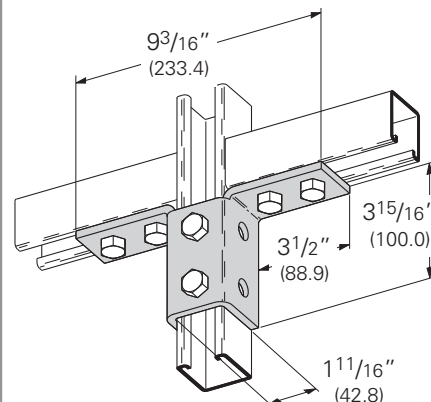

**B122**  
**Six Hole Triple Wing Connection**

- Standard finishes: ZN, GRN
- Wt./C 110 Lbs. (49.9 kg)

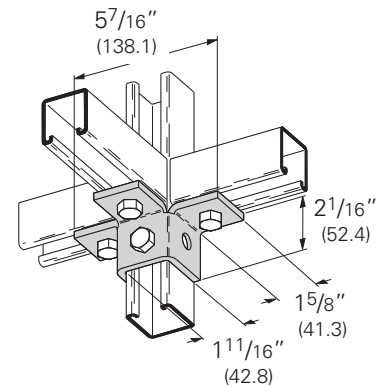

Reference page 106 for general fitting and standard finish specifications.

# Wing Fittings

## B123 Twelve Hole Triple Wing Connection

- Standard finishes: ZN, GRN
- Wt./C 234 Lbs. (106.1 kg)

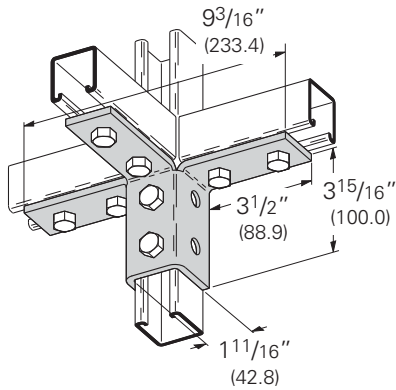

## B124 Nine Hole Triple Wing Connection

- Standard finishes: ZN, GRN
- Wt./C 177 Lbs. (80.3 kg)

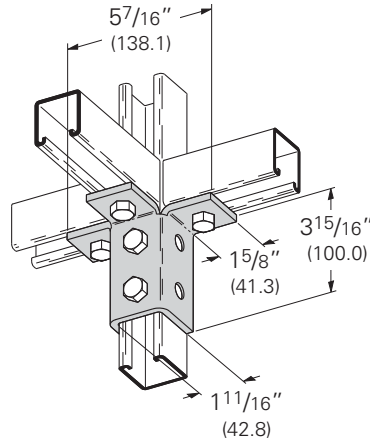

## B276 Fourteen Hole Double Corner Gusseted Connection

- Standard finishes: ZN, GRN
- Wt./C 196 Lbs. (88.9 kg)

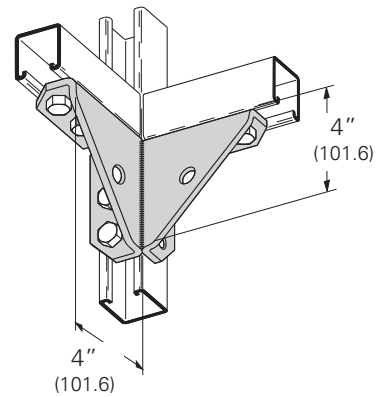

## B274R Eight Hole Single Corner Gusseted Connection (Right Hand)

- Standard finishes: ZN, GRN
- Wt./C 176 Lbs. (79.8 kg)

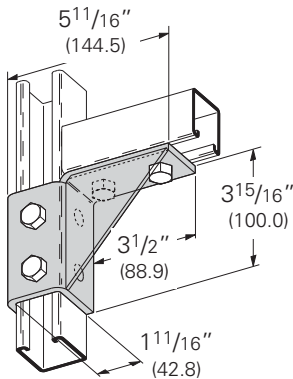

## B274L Eight Hole Single Corner Gusseted Connection (Left Hand)

- Standard finishes: ZN, GRN
- Wt./C 176 Lbs. (79.8 kg)

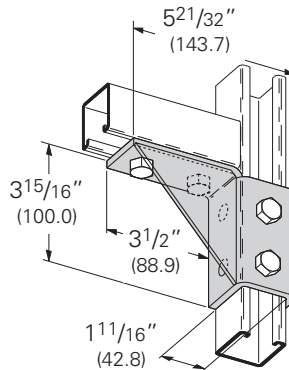

## B495 Ten Hole Double Wing Gusseted Connection

- Standard finishes: ZN, GRN
- Wt./C 240 Lbs. (108.8 kg)

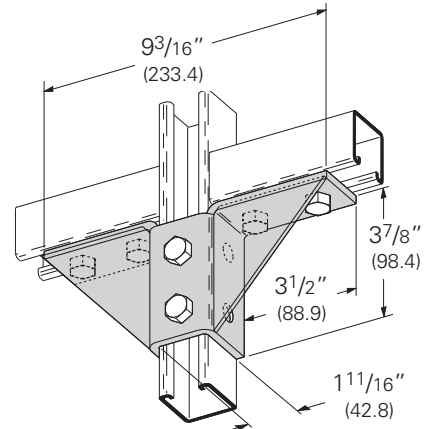

## B277 Twelve Hole Triple Wing Gusseted Connection

- Standard finishes: ZN, GRN
- Wt./C 285 Lbs. (129.3 kg)

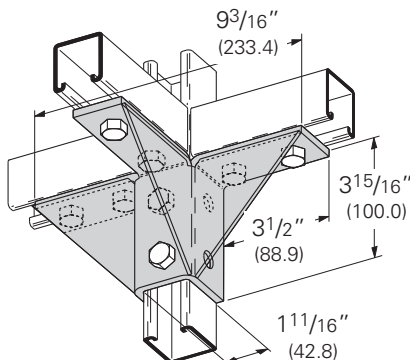

## B362 Eight Hole Double Corner Gusseted Connection

- Standard finishes: ZN, GRN
- Wt./C 226 Lbs. (102.5 kg)

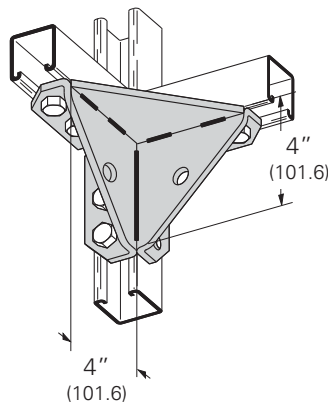

## B571 Eight Hole Wing Connection

- Standard finishes: ZN, GRN
- Wt./C 201 Lbs. (91.2 kg)

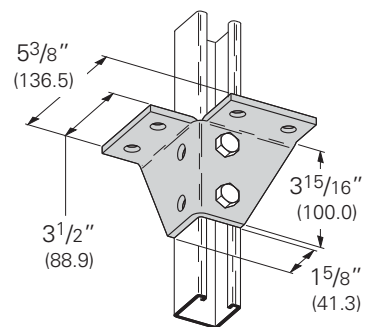

Reference page 106 for general fitting and standard finish specifications.

**B346L**  
**Eight Hole Double Corner Gussetted Connection**  
**(Left Hand)**

- Standard finishes: ZN, GRN
- Wt./C 242 Lbs. (109.8 kg)

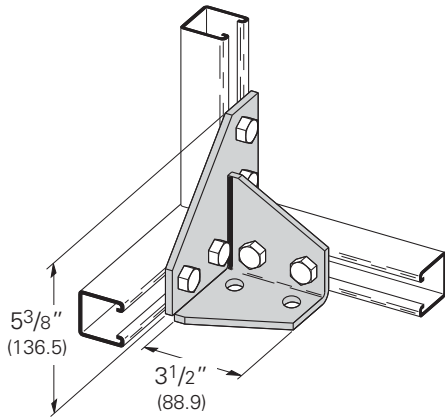

**B346R**  
**Eight Hole Double Corner Gussetted Connection**  
**(Right Hand)**

- Standard finishes: ZN, GRN
- Wt./C 242 Lbs. (109.8 kg)

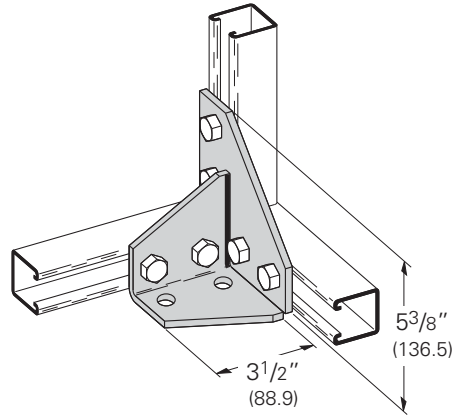

**B279**  
**Post Base for B22**

- Standard finishes: ZN, GRN
- Wt./C 314 Lbs. (142.4 kg)

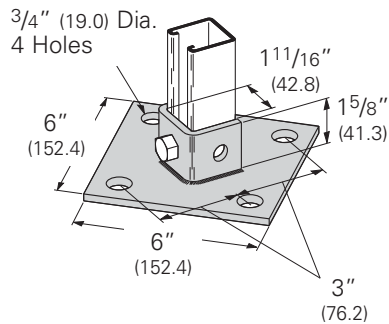

**B279SQ**  
**Post Base for B22**

- Standard finishes: ZN, GRN
- Wt./C 314 Lbs. (142.4 kg)

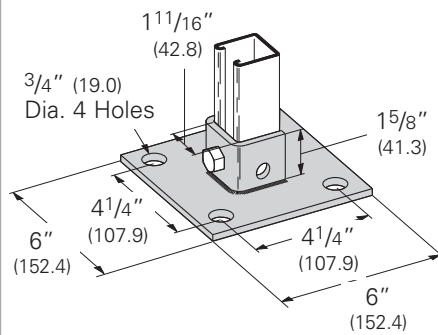

**B279FL**  
**Post Base for B22**

- Standard finishes: ZN, GRN
- Wt./C 230 Lbs. (104.3 kg)

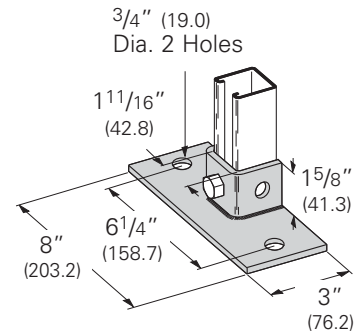

**B280**  
**Post Base for B22**

- Standard finishes: ZN, GRN, HDG, SS4, AL
- Wt./C 392 Lbs. (177.8 kg)

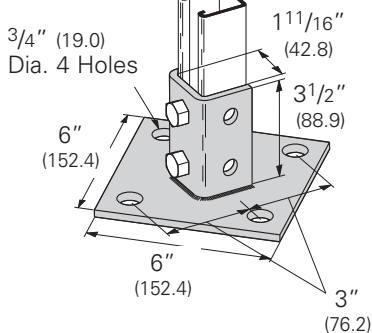

**B280SQ**  
**Post Base for B22**

- Standard finishes: ZN, GRN, HDG, SS4, AL
- Wt./C 392 Lbs. (177.8 kg)

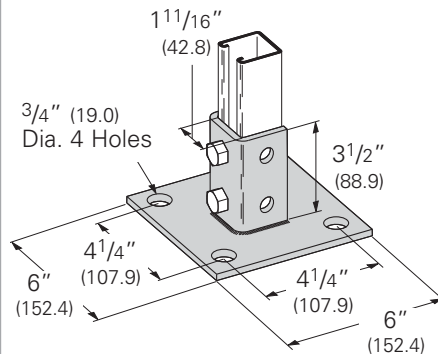

**B280FL**  
**Post Base for B22**

- Standard finishes: ZN, GRN, HDG, SS4
- Wt./C 312 Lbs. (141.5 kg)

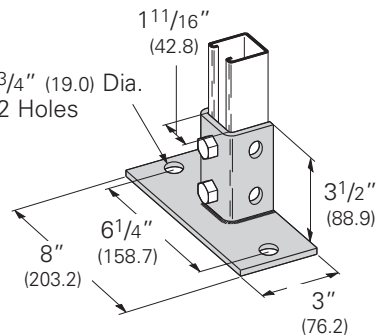

Reference page 106 for general fitting and standard finish specifications.



# Post Bases

## B281A Post Base for B22A, B, C, ETC.

- Standard finishes: ZN, GRN
- Wt./C 330 Lbs. (149.7 kg)

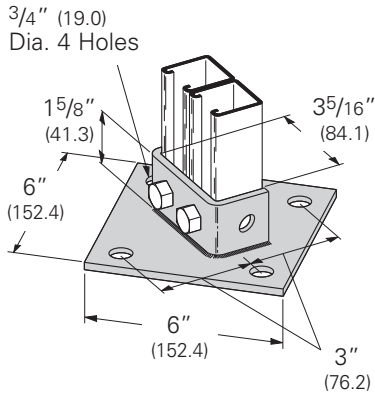

## B281ASQ Post Base for B22A, B, C, Etc.

- Standard finishes: ZN, GRN
- Wt./C 330 Lbs. (149.7 kg)

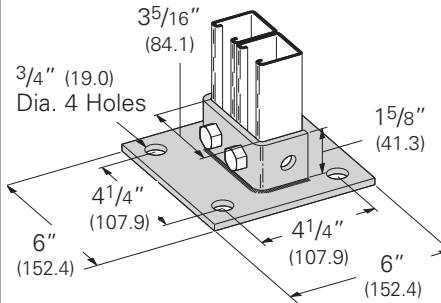

## B281AFL Post Base for B22A, B, C, Etc.

- Standard finishes: ZN, GRN
- Wt./C 250 Lbs. (113.4 kg)

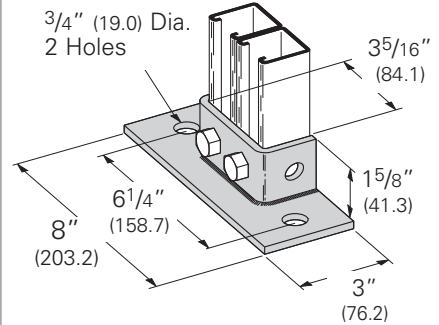

## B281 Post Base for B22A, B, C, Etc.

- Standard finishes: ZN, GRN, HDG
- Wt./C 400 Lbs. (181.4 kg)

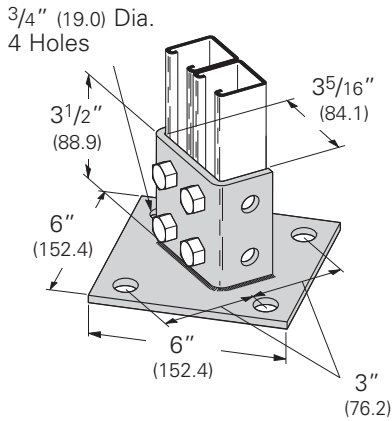

## B281SQ Post Base for B22A, B, C, Etc.

- Standard finishes: ZN, GRN, HDG, SS4
- Wt./C 400 Lbs. (181.4 kg)

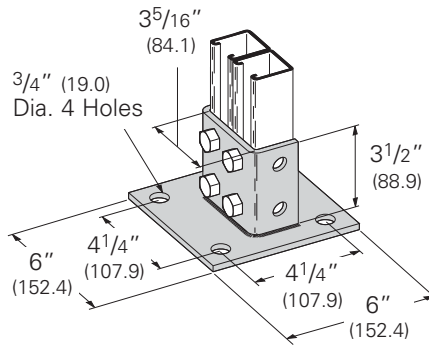

## B281FL Post Base for B22A, B, C, Etc.

- Standard finishes: ZN, GRN
- Wt./C 320 Lbs. (145.1 kg)

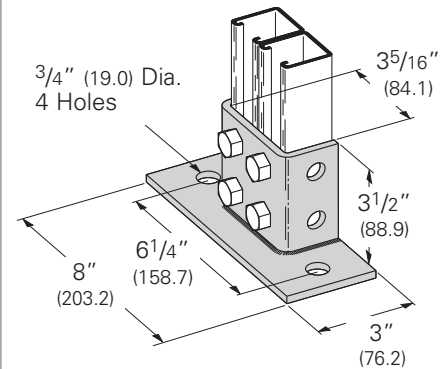

## B281M Post Base for B22-2PL

- Standard finishes: ZN, GRN
- Wt./C 470 Lbs. (213.2 kg)

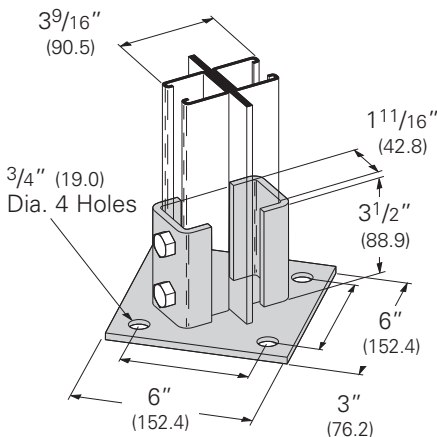

## B281MSQ Post Base for B22-2PL

- Standard finishes: ZN, GRN
- Wt./C 470 Lbs. (213.2 kg)

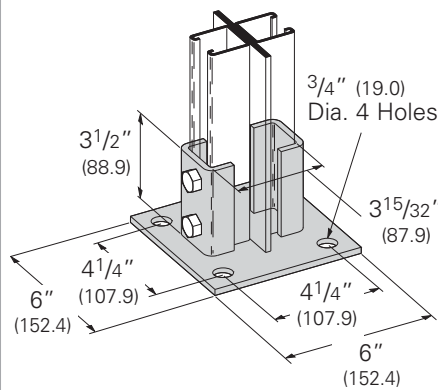

## B570 Post Base for Four Channel Combinations

- Standard finishes: ZN, GRN
- Wt./C 397 Lbs. (180.1 kg)

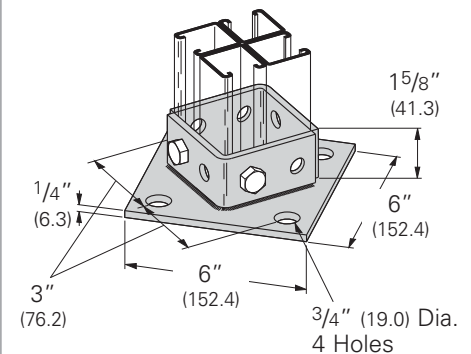

Reference page 106 for general fitting and standard finish specifications.

## B570A Post Base for Four Channel Combinations

- Standard finishes: ZN, GRN
- Wt./C 550 Lbs. (249.5 kg)

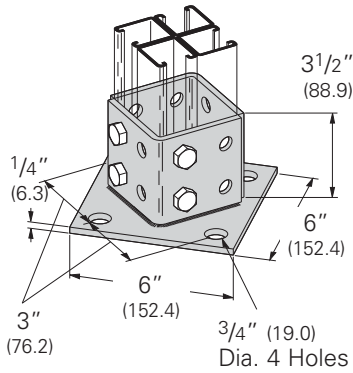

## B278 Post Base for B22

- Standard finishes: ZN, GRN
- Wt./C 288 Lbs. (130.6 kg)

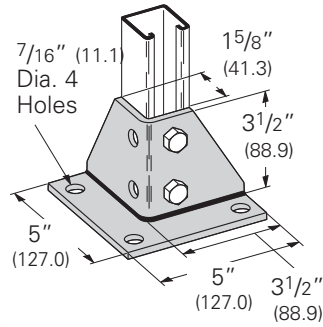

## B585 Post Base for B22A

- Standard finishes: ZN, GRN
- Wt./C 97 Lbs. (44.0 kg)

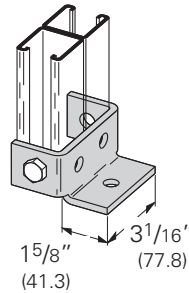

## B300 Post Base

- Material: Malleable Iron
- Standard finishes: ZN, GRN
- Wt./C 259 Lbs. (117.5 kg)

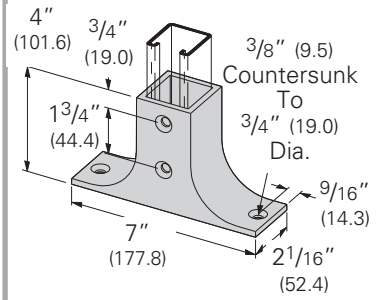

## B187 Bracket

- Uniform Loading 1450 Lbs. (6.45 kN)
- Safety Factor of 2.5
- Hole Spacing on Bracket Top 5 5/16" (150.8) Center to Center
- Standard finishes: ZN, GRN
- Wt./C 193 Lbs. (87.5 kg)

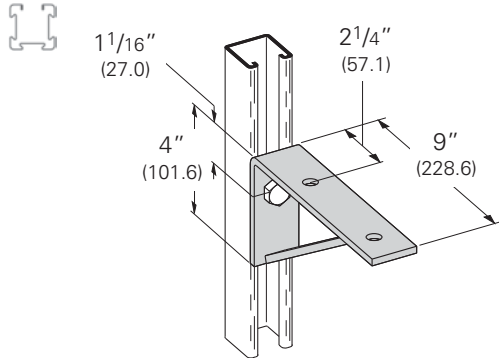

## B188 Bracket

- Uniform Loading 1080 Lbs. (4.80 kN)
- Safety Factor of 2.5
- Hole Spacing on Bracket Top 8 15/16" (227.0) Center to Center
- Standard finishes: ZN, GRN
- Wt./C 241 Lbs. (109.3 kg)

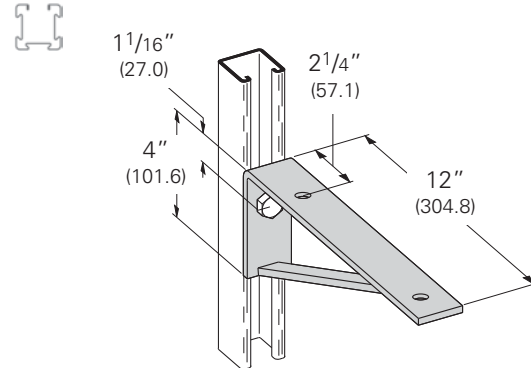

## B189 Bracket

- Uniform Loading 870 Lbs. (3.87 kN)
- Safety Factor of 2.5
- Hole Spacing on Bracket Top 11 15/16" (303.2) Center to Center
- Standard finishes: ZN, GRN
- Wt./C 308 Lbs. (139.7 kg)

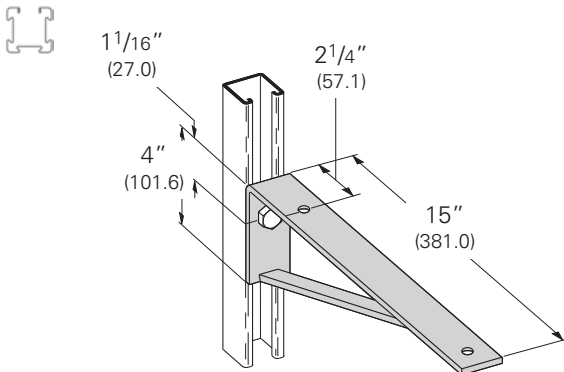

## B541 Bracket

- Uniform Loading 1240 Lbs. (5.51 kN)
- Safety Factor of 2.5
- Hole Spacing on Bracket Top 7 7/16" (188.9) Center to Center
- Standard finishes: ZN, GRN
- Wt./C 201 Lbs. (91.2 kg)

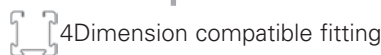
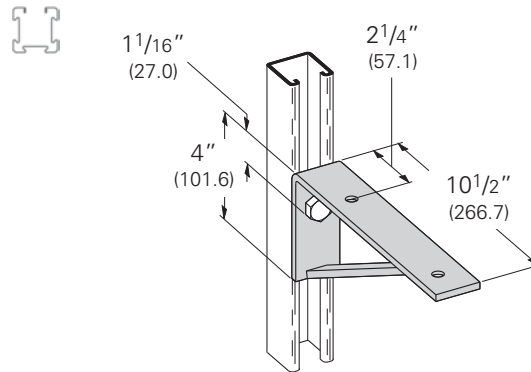

Reference page 106 for general fitting and standard finish specifications.

# Post Bases & Brackets

## B190 12" (304.8) Bracket

- Uniform Loading 900 Lbs. (4.00 kN)
- Safety Factor of 2.5
- Standard finishes: ZN, GRN
- Wt./C 260 Lbs. (117.9 kg)

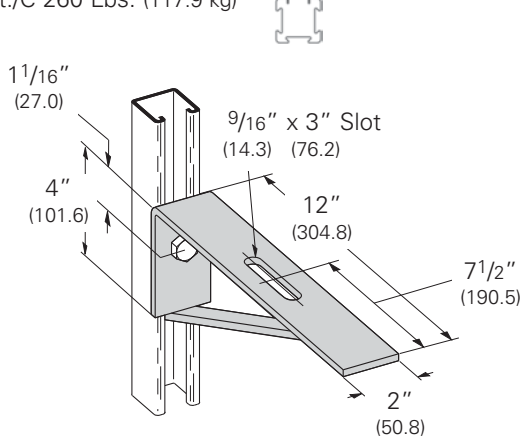

## B191-18 18" (457.2) Bracket

- Uniform Loading 600 Lbs. (2.67 kN)
- Safety Factor of 2.5
- Standard finishes: ZN, GRN
- Wt./C 377 Lbs. (171.0 kg)

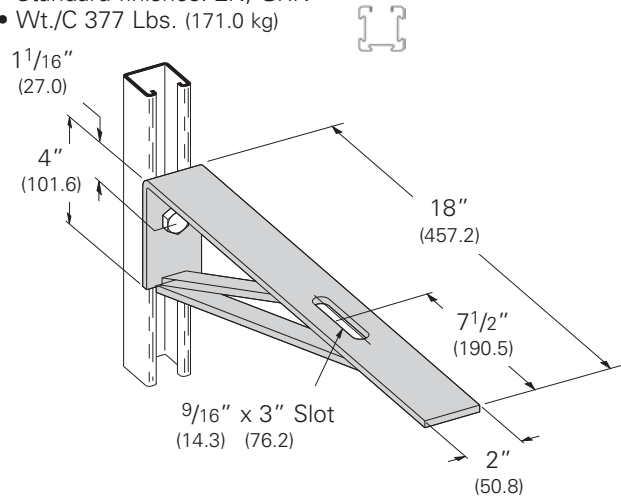

## B289-12 12 1/2" (317.5) Bracket

- Uniform Loading 1040 Lbs. (4.63 kN)
- Safety Factor of 2.5
- Standard finishes: ZN, GRN
- Wt./C 285 Lbs. (129.3 kg)

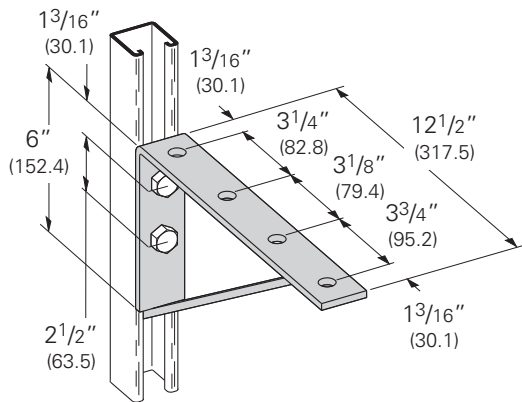

## B191-24 24" (609.6) Bracket

- Uniform Loading 450 Lbs. (2.00 kN)
- Safety Factor of 2.5
- Standard finishes: ZN, GRN
- Wt./C 377 Lbs. (171.0 kg)

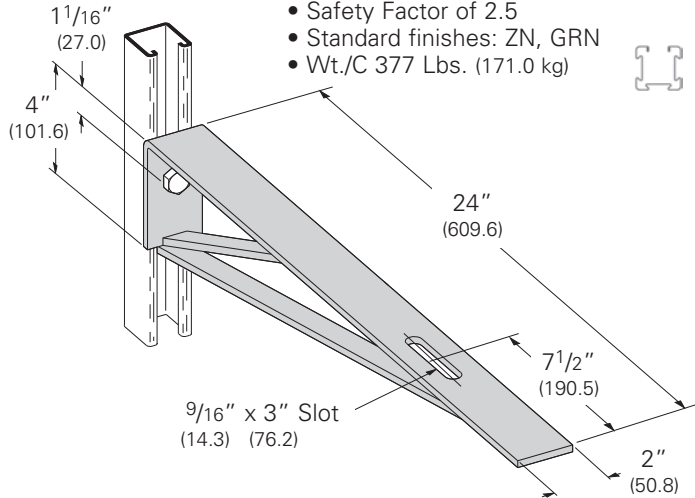

## B290 16 1/2" (419.1) Bracket

- Uniform Loading 1200 Lbs. (5.34 kN)
- Safety Factor of 2.5
- Standard finishes: ZN, GRN
- Wt./C 405 Lbs. (183.7 kg)

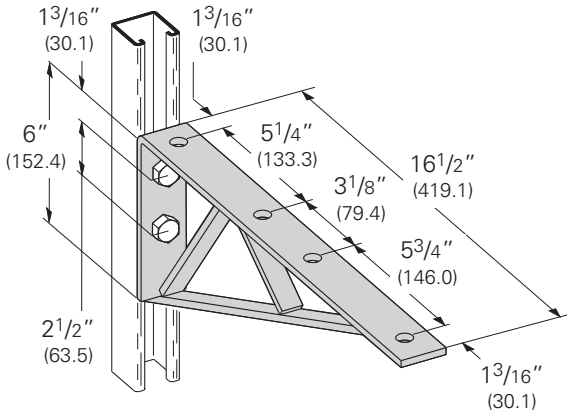

## B192 24" (609.6) Bracket

- Uniform Loading 820 Lbs. (3.65 kN)
- Safety Factor of 2.5
- Standard finishes: ZN, GRN
- Wt./C 576 Lbs. (261.3 kg)

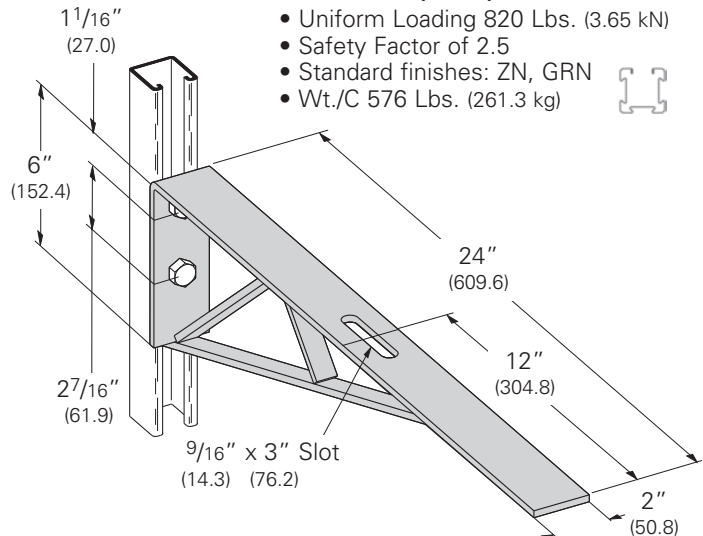

Reference page 106 for general fitting and standard finish specifications.

## B289-14 14<sup>1</sup>/<sub>2</sub>" (368.3) Bracket

- Uniform Loading 900 Lbs. (4.00 kN)
- Safety Factor of 2.5
- Standard finishes: ZN, GRN
- Wt./C 295 Lbs. (133.8 kg)

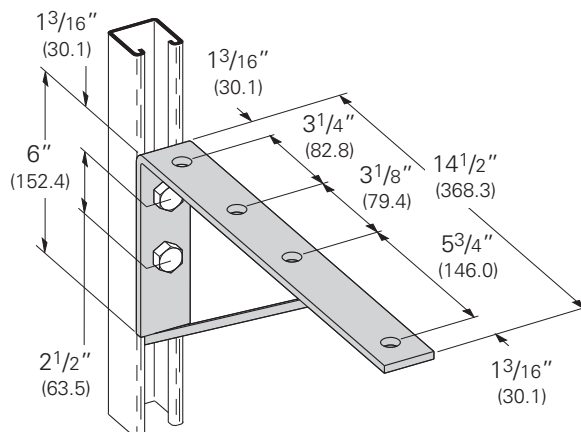

## B291 18<sup>1</sup>/<sub>2</sub>" (469.9) Bracket

- Uniform Loading 1070 Lbs. (4.76 kN)
- Safety Factor of 2.5
- Standard finishes: ZN, GRN
- Wt./C 468 Lbs. (212.3 kg)

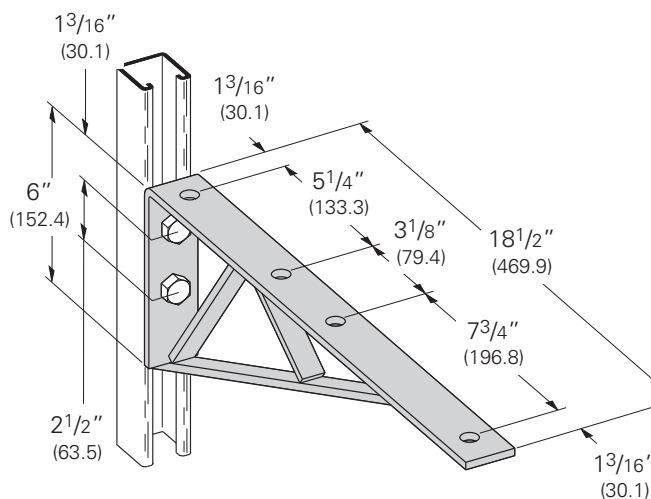

## B292 20<sup>1</sup>/<sub>2</sub>" (520.7) Bracket

- Uniform Loading 600 Lbs. (2.67 kN)
- Safety Factor of 2.5
- Standard finishes: ZN, GRN, HDG, SS4
- Wt./C 490 Lbs. (222.2 kg)

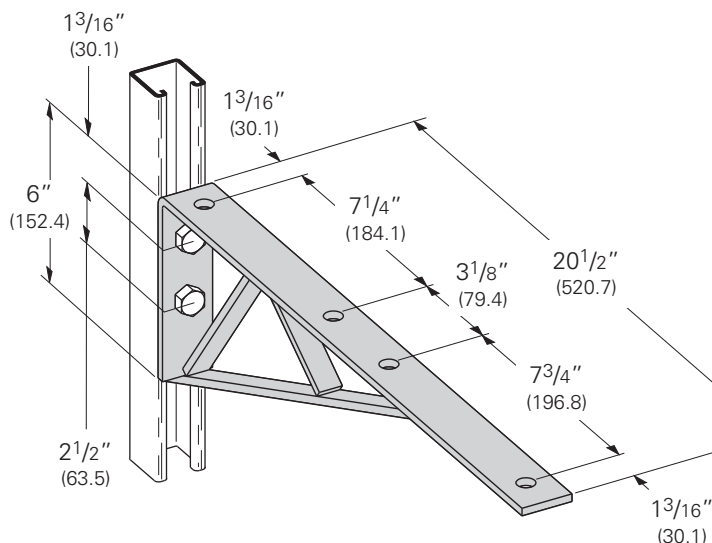

4Dimension compatible fitting

Reference page 106 for general fitting and standard finish specifications.

# Brackets

## B409 Single Channel Bracket

- Safety Factor of 2.5
- Standard finishes: ZN, GRN, SS4



Part No.	A		Uniform Load		Wt./C	
	In.	mm	Lbs.	kN	Lbs.	kg
B409-6	6"	(152.4)	1920	(8.54)	152	(68.9)
B409-9	9"	(228.6)	1280	(5.69)	195	(88.4)
B409-12	12"	(304.8)	960	(4.27)	232	(105.2)
B409-14	14"	(355.6)	800	(3.56)	274	(124.3)
B409-16	16"	(406.4)	730	(3.25)	314	(142.4)
B409-18	18"	(457.2)	640	(2.84)	347	(157.4)
B409-24	24"	(609.6)	480	(2.13)	450	(204.1)

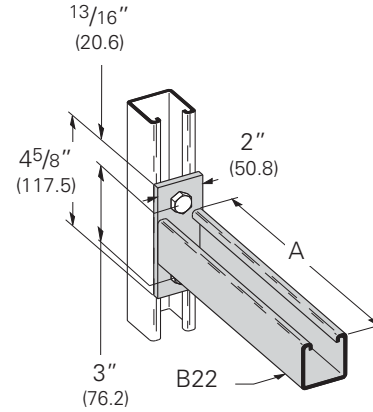

## B297 Double Channel Bracket

- Safety Factor of 2.5
- Standard finishes: ZN, GRN, HDG



Part No.	A		Uniform Load		Wt./C	
	In.	mm	Lbs.	kN	Lbs.	kg
B297-12	12"	(304.8)	1660	(7.37)	485	(220.0)
B297-18	18"	(457.2)	1100	(4.88)	668	(303.0)
B297-24	24"	(609.6)	835	(3.71)	857	(388.7)
B297-30	30"	(762.0)	665	(2.95)	1040	(471.7)
B297-36	36"	(914.4)	550	(2.44)	1240	(562.4)
B297-42	42"	(1066.8)	465	(2.06)	1440	(653.2)

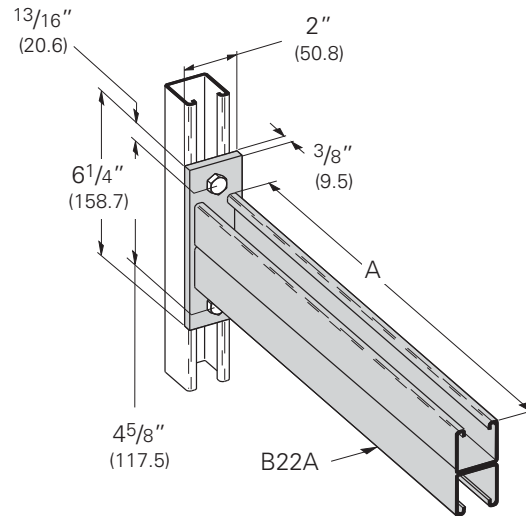

## B494 Braced Single Bracket

- Safety Factor of 2.5
- Standard finishes: ZN, GRN



Part No.	L		H		Uniform Load		Wt. /C	
	In.	mm	In.	mm	Lbs.	kN	Lbs.	kg
B494-12	12"	(304.8)	8 <sup>3</sup> / <sub>4</sub> "	(222.2)	2500	(11.12)	392	(178.0)
B494-18	18"	(475.2)	8 <sup>3</sup> / <sub>4</sub> "	(222.2)	1700	(7.56)	509	(231.0)
B494-24	24"	(609.6)	8 <sup>3</sup> / <sub>4</sub> "	(222.2)	1300	(5.78)	635	(288.0)
B494-30	30"	(762.0)	11 <sup>1</sup> / <sub>4</sub> "	(285.7)	1600	(7.11)	885	(402.8)
B494-36	36"	(914.4)	11 <sup>1</sup> / <sub>4</sub> "	(285.7)	1100	(4.89)	1024	(464.5)
B494-42	42"	(1066.8)	16"	(406.4)	980	(4.36)	1285	(582.9)
B494-48	48"	(1219.2)	16"	(406.4)	980	(4.36)	1409	(639.1)

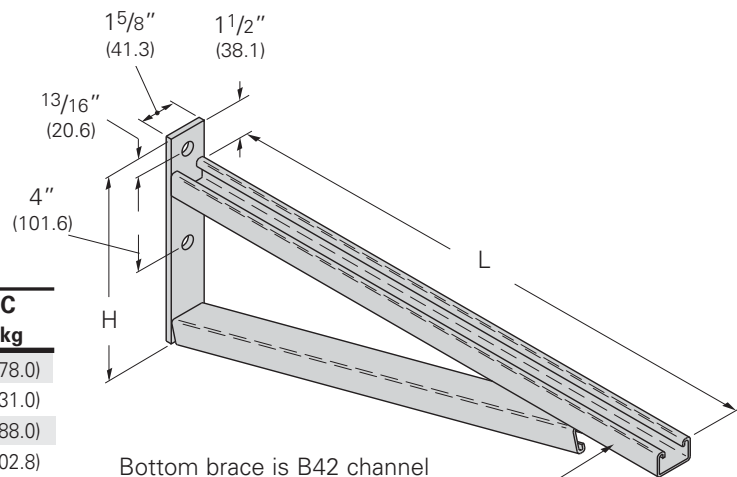

Bottom brace is B42 channel on B494-24 and smaller and B22 channel on B494-30 and larger

4Dimension compatible fitting

Reference page 106 for general fitting and standard finish specifications.

## B174SH-B186SH L&R Slotted Bracket

- Safety Factor of 2.5
- Specify L for left or R for right bracing
- Material: ASTM A1011 33,000 PSI min. yield
- Standard finishes: ZN, GRN

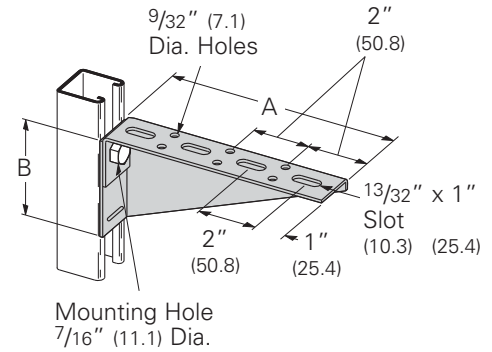

Mounting Hole  
7/16" (11.1) Dia.

Right bracket shown, left bracket gussett on opposite side.

Part No.	A		B		Uniform Load		Wt./C	
	In.	mm	In.	mm	Lbs.	kN	Lbs.	kg
<b>B174SH</b>	24"	(609.6)	67/16"	(163.5)	225	(1.00)	370	(167.8)
<b>B175SH</b>	26"	(660.4)	615/16"	(176.2)	225	(1.00)	425	(192.8)
<b>B176SH</b>	28"	(711.2)	77/16"	(188.9)	225	(1.00)	480	(217.7)
<b>B177SH</b>	30"	(762.0)	715/16"	(201.6)	225	(1.00)	520	(235.9)
<b>B178SH</b>	12"	(304.8)	37/16"	(87.3)	350	(1.55)	143	(64.8)
<b>B179SH</b>	14"	(355.6)	315/16"	(100.0)	350	(1.55)	162	(73.5)
<b>B180SH</b>	16"	(406.4)	47/16"	(112.7)	250	(1.11)	204	(92.5)
<b>B181SH</b>	18"	(457.2)	415/16"	(125.4)	250	(1.11)	232	(105.2)
<b>B182SH</b>	20"	(508.0)	57/16"	(138.1)	250	(1.11)	275	(124.7)
<b>B183SH</b>	22"	(558.8)	515/16"	(150.8)	250	(1.11)	317	(143.8)
<b>B184SH</b>	6"	(152.4)	115/16"	(49.2)	225	(1.00)	58	(26.3)
<b>B185SH</b>	8"	(203.2)	27/16"	(61.9)	225	(1.00)	82	(37.2)
<b>B186SH</b>	10"	(254.0)	215/16"	(74.6)	325	(1.44)	103	(46.7)

## B196 Channel Clevis Bracket

- Safety Factor of 2.5
- Standard finishes: ZN, GRN

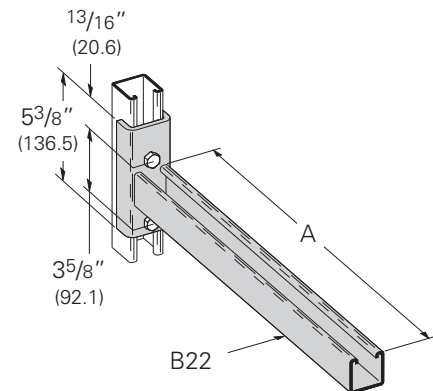

Part No.	A		Uniform Load		Wt./C	
	In.	mm	Lbs.	kN	Lbs.	kg
<b>B196-18</b>	18"	(457.2)	600	(2.67)	430	(195.0)
<b>B196-24</b>	24"	(609.6)	450	(2.00)	510	(231.3)

## B198 Channel Clevis Bracket

- Safety Factor of 2.5
- Standard finishes: ZN, GRN

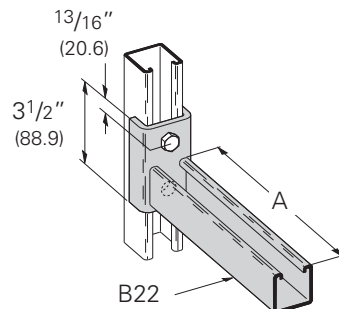

Part No.	A		Uniform Load		Wt./C	
	In.	mm	Lbs.	kN	Lbs.	kg
<b>B198-6</b>	6"	(152.4)	1600	(7.12)	185	(83.9)
<b>B198-12</b>	12"	(304.8)	800	(3.56)	284	(128.8)

## B198A Channel Clevis Bracket

- Safety Factor of 2.5
- Standard finishes: ZN, GRN

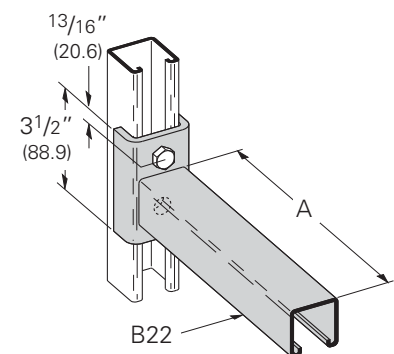

Part No.	A		Uniform Load		Wt./C	
	In.	mm	Lbs.	kN	Lbs.	kg
<b>B198A-6</b>	6"	(152.4)	1600	(7.12)	185	(83.9)
<b>B198A-12</b>	12"	(304.8)	800	(3.56)	284	(128.8)

4Dimension compatible fitting

Reference page 106 for general fitting and standard finish specifications.

# Brackets

## B293 Channel Bracket

- Safety Factor of 2.5
- Standard finishes: ZN, GRN

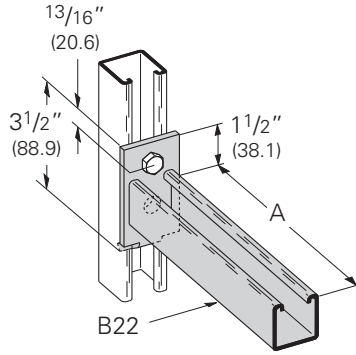

Part No.	A		Uniform Load		Wt./C	
	In.	mm	Lbs.	kN	Lbs.	kg
<b>B293-6</b>	6"	(152.4)	1200	(5.34)	144	(65.3)
<b>B293-12</b>	12"	(304.8)	600	(2.67)	252	(114.3)
<b>B293-18</b>	18"	(457.2)	400	(1.78)	340	(154.2)
<b>B293-24</b>	24"	(609.6)	300	(1.33)	412	(186.9)

## B293A Channel Bracket

- Safety Factor of 2.5
- Standard finishes: ZN, GRN

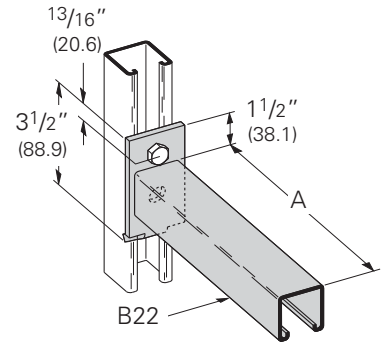

Part No.	A		Uniform Load		Wt./C	
	In.	mm	Lbs.	kN	Lbs.	kg
<b>B293A-6</b>	6"	(152.4)	1200	(5.34)	144	(65.3)
<b>B293A-12</b>	12"	(304.8)	600	(2.67)	252	(114.3)
<b>B293A-18</b>	18"	(457.2)	400	(1.78)	340	(154.2)
<b>B293A-24</b>	24"	(609.6)	300	(1.33)	412	(186.9)

## B194 Bracket for B22 & B24

- Safety Factor of 2.5
- 6300 In.-Lbs (712 N•m) applies to fitting only, not to strength of strut arm
- Refer to pages 56, 57 & 59 for strut loading data
- Standard finishes: ZN, GRN
- Wt./C 210 Lbs. (95.2 kg)

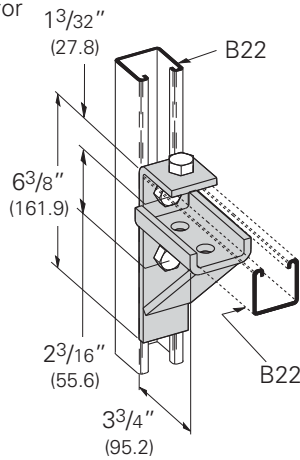

## B370 Bracket for B22A & B11

- Safety Factor of 2.5
- 13000 In.-Lbs (1469 N•m) applies to fitting only, not to strength of strut arm
- Refer to pages 51, 56, & 57 for strut loading data
- Standard finishes: ZN, GRN
- Wt./C 266 Lbs. (120.6 kg)

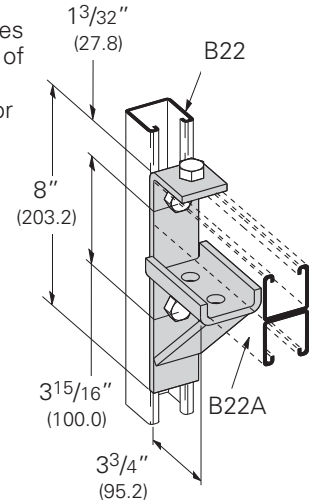

## B195 Bracket for B42

- Safety Factor of 2.5
- 2500 In.-Lbs (282 N•m) applies to fitting only, not to strength of strut arm
- Refer to pages 57 & 65 for strut loading data
- Standard finishes: ZN, GRN
- Wt./C 174 Lbs. (78.9 kg)

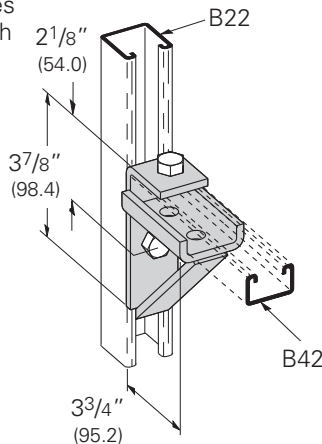

## B440 Bracket for B52 & B54

- Safety Factor of 2.5
- 2000 In.-Lbs (226 N•m) applies to fitting only, not to strength of strut arm
- Refer to page 57, 67, & 69 for strut loading data
- Standard finishes: ZN, GRN
- Wt./C 177 Lbs. (80.3 kg)

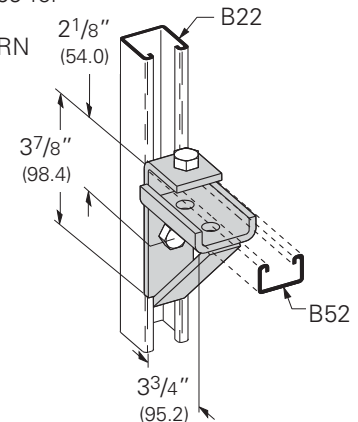

4Dimension compatible fitting

Reference page 106 for general fitting and standard finish specifications.

## B449-4, 8 & 12 Cable Saddle Bracket

- Safety Factor of 2.5
- Material: 11 Gauge (3.0) ASTM A1011 HSLAS Gr. 50
- Standard finishes: ZN, GRN



Part No.	A		B		Uniform Load		Wt./C	
	In.	mm	In.	mm	Lbs.	kN	Lbs.	kg
<b>B449-4</b>	4 <sup>1</sup> / <sub>2</sub> "	(114.3)	2 <sup>3</sup> / <sub>8</sub> "	(60.3)	2400	(10.67)	74	(33.5)
<b>B449-8</b>	8 <sup>1</sup> / <sub>2</sub> "	(215.9)	2 <sup>3</sup> / <sub>8</sub> "	(60.3)	1270	(5.65)	124	(56.2)
<b>B449-12</b>	12 <sup>1</sup> / <sub>2</sub> "	(317.5)	4"	(101.6)	860	(3.82)	184	(83.4)

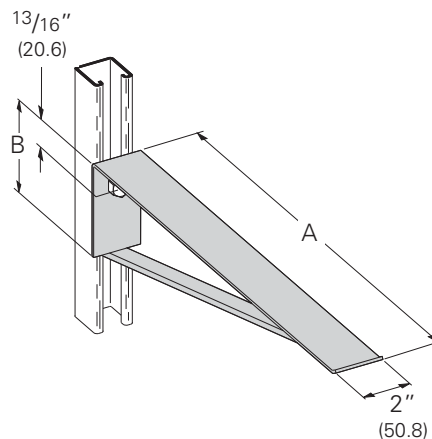

## B449-18 18" (457.2) Cable Saddle Bracket

- Safety Factor of 2.5
- Uniform Load 960 Lbs. (4.17 kN)
- Material: 11 Gauge (3.0) ASTM A1011 HSLAS Gr. 50
- Standard finishes: ZN, GRN
- Wt./C 312 Lbs. (141.5 kg)

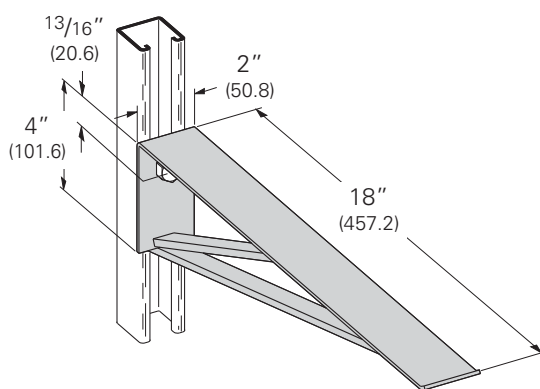

## B409DB Series Solar Bracket

- Safety Factor of 2.5
- Includes: (1) Channel Bracket Plate - 1/4" x 3 1/2" x 7 3/4" with welded channel  
(1) Back Plate - 1/4" x 3 1/2" x 7 3/4"  
(4) 3/8"-16 x 8 1/2" Square Neck Carriage Bolts  
(4) 3/8"-16 Serrated Flange Hex Nuts
- Fits 4" (101mm) to 6 1/2" (165mm) wide supports
- Standard finishes: ZN, HDG

Part No.	L		Uniform Load		Wt./C	
	In.	mm	Lbs.	kN	Lbs.	kg
<b>B409DB-12</b>	12"	(304.8)	800	(3.56)	766	(347.4)
<b>B409DB-18</b>	18"	(457.2)	800	(3.56)	956	(433.6)

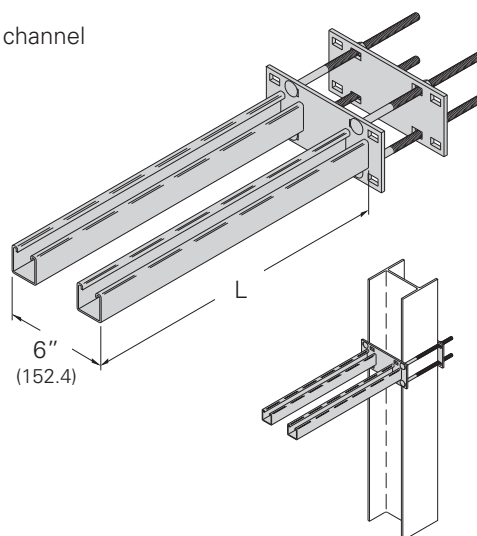

A single channel version and other lengths are available.  
Contact Eaton B-Line Division engineering for more information.



Reference page 106 for general fitting and standard finish specifications.



# Brackets

## B816

- Standard finishes: ZN, HDG

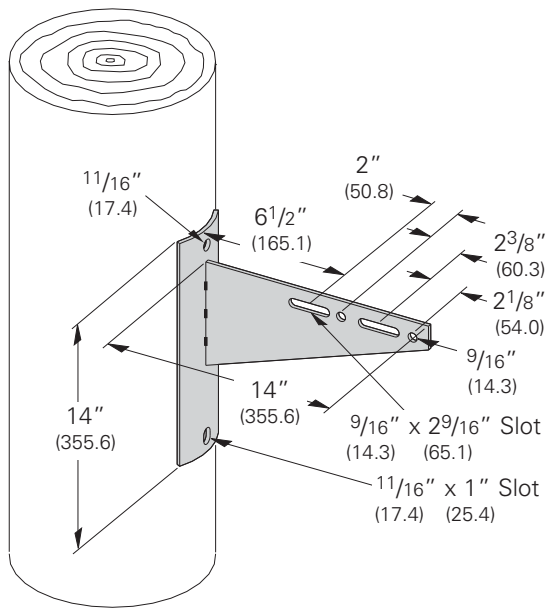

## B852S-\*.\*\*\*

- \*Specify Width: W = 8, 12, 16
- \*\*Specify Depth: D = 6, 8, 10, 12, 16, 18, 24
- 13/16" (20.6mm) x 1" (25.4mm) banding slots for steel band
- Standard finishes: ZN, HDG

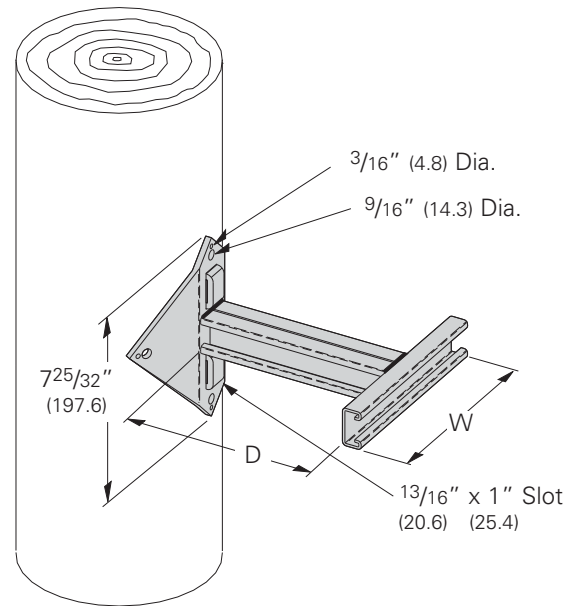

## B802D-\*

- \*Specify Width: W = 8, 12, 16
- Standard finishes: ZN, HDG

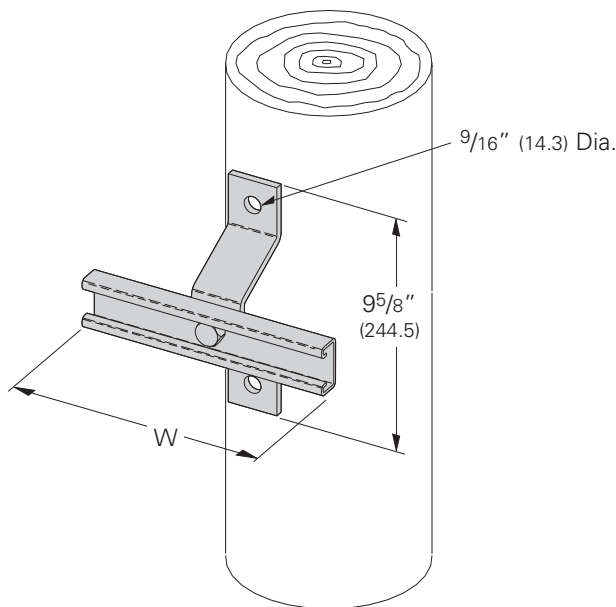

## B810-\*

- \*Specify Width: W = 8, 12, 16
- 13/16" (20.6mm) x 1" (25.4mm) banding slots for steel band
- Standard finishes: ZN, HDG

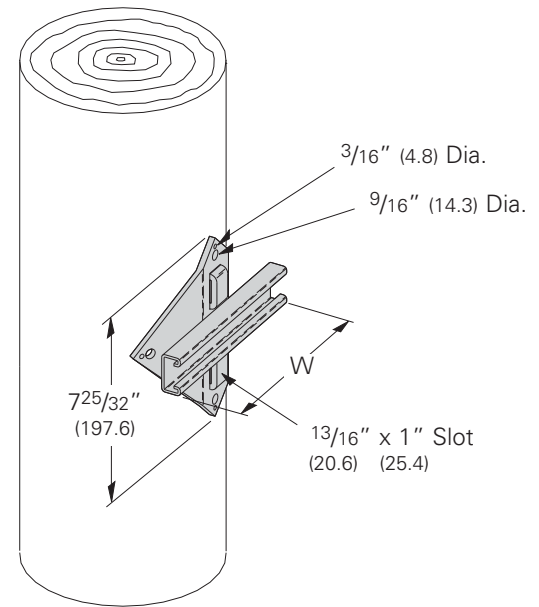

Reference page 106 for general fitting and standard finish specifications.

## B811-\*

- \*Specify Width: W = 8, 12, 16
- Can be attached directly to B809 & B812
- Standard finishes: ZN, HDG

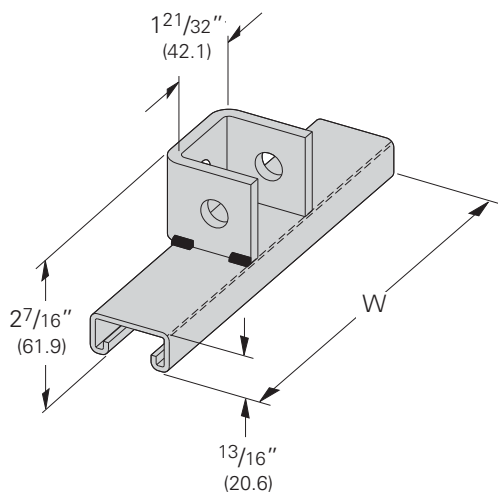

## B812-\*

- \*Specify Depth: D = 6, 8, 12, 16, 18, 24
- 13/16" (20.6mm) x 1" (25.4mm) banding slots for steel band
- Standard finishes: ZN, HDG

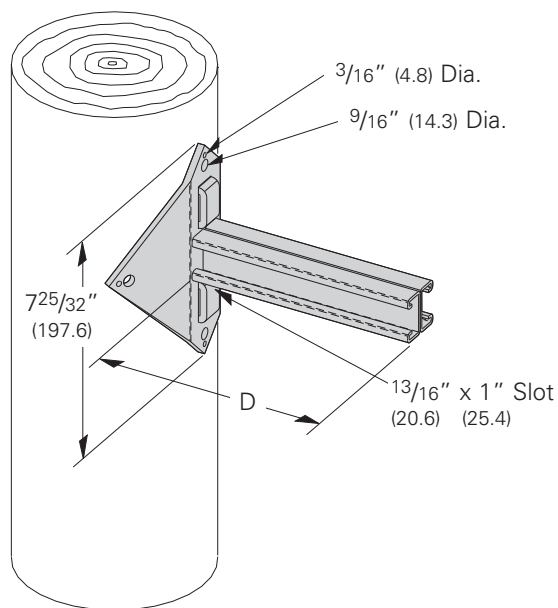

## B809B-\*

- \*Specify Depth: D = 6, 8, 10, 12, 16, 18, 24
- 13/16" (20.6mm) x 1" (25.4mm) banding slots for steel band
- Standard finishes: ZN, HDG

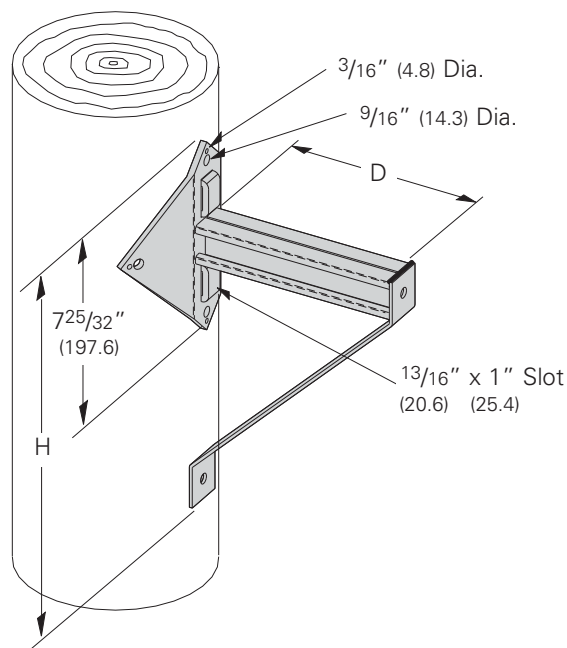

Part No.	D		H	
	In.	mm	In.	mm
<b>B809B-6</b>	6"	(152.4)	12 <sup>3</sup> / <sub>4</sub> "	(323.9)
<b>B809B-8</b>	8"	(203.2)	14 <sup>3</sup> / <sub>4</sub> "	(374.7)
<b>B809B-10</b>	10"	(254.0)	16 <sup>3</sup> / <sub>4</sub> "	(425.5)
<b>B809B-12</b>	12"	(304.8)	18 <sup>3</sup> / <sub>4</sub> "	(476.2)
<b>B809B-16</b>	16"	(406.4)	22 <sup>3</sup> / <sub>4</sub> "	(577.8)
<b>B809B-18</b>	18"	(457.2)	24 <sup>3</sup> / <sub>4</sub> "	(628.6)
<b>B809B-24</b>	24"	(609.6)	27 <sup>3</sup> / <sub>4</sub> "	(704.8)

Reference page 106 for general fitting and standard finish specifications.

# Miscellaneous Fittings

## B214 R&L Reel Rack Support for 1 1/4" (32) Pipe

- Standard finishes: ZN, GRN
- Wt./C 200 Lbs. (90.7 kg)

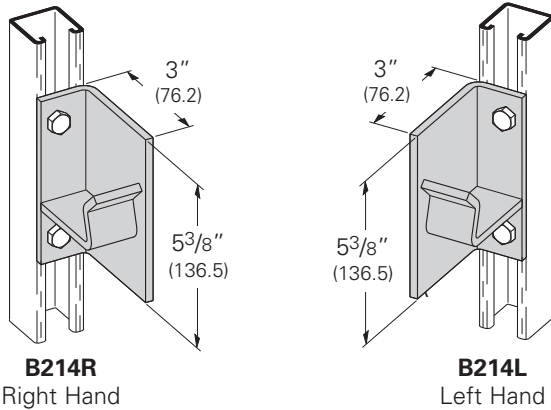

**B214R**  
Right Hand

**B214L**  
Left Hand

## B514 R&L Reel Rack Support for 2" (50) Pipe

- Standard finishes: ZN, GRN
- Wt./C 246 Lbs. (111.6 kg)

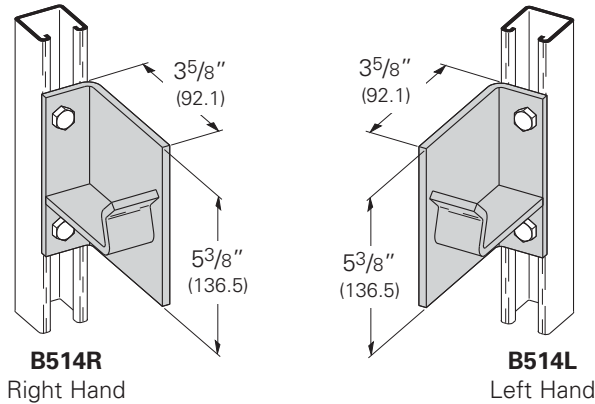

**B514R**  
Right Hand

**B514L**  
Left Hand

## B475 Double Reel Rack Support on Single Channel for 1 1/4" (32) Pipe

- Standard finishes: ZN, GRN
- Wt./C 326 Lbs. (147.9 kg)

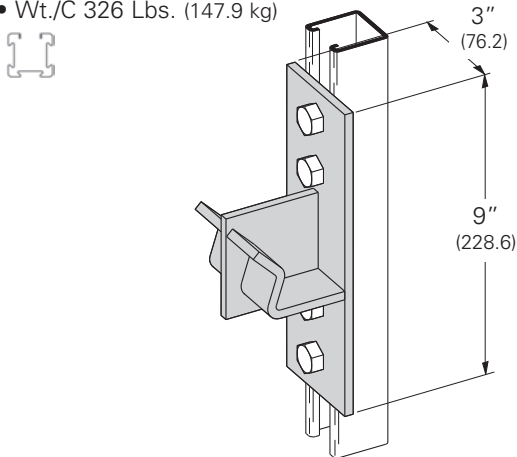

## B473 Double Reel Rack Support on Single Channel for 2" (50) Pipe

- Standard finishes: ZN, GRN
- Wt./C 351 Lbs. (159.2 kg)

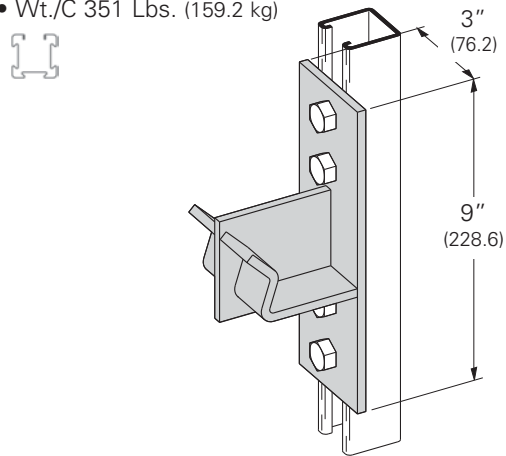

## B474 Double Reel Rack Support on Double Channel for 1 1/4" (32) Pipe

- Standard finishes: ZN, GRN
- Wt./C 257 Lbs. (116.6 kg)

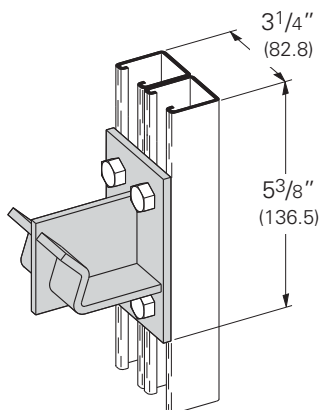

## B472 Double Reel Rack Support on Double Channel for 2" (50) Pipe

- Standard finishes: ZN, GRN
- Wt./C 299 Lbs. (135.6 kg)

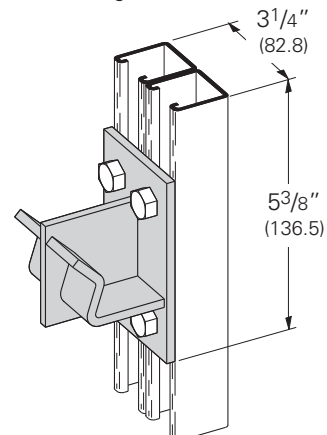

 4Dimension compatible fitting

Reference page 106 for general fitting and standard finish specifications.

## B438 Pipe Support Bracket

- Standard finishes: ZN, GRN
- Material: ASTM A36
- Wt./C 132 Lbs. (59.9 kg)

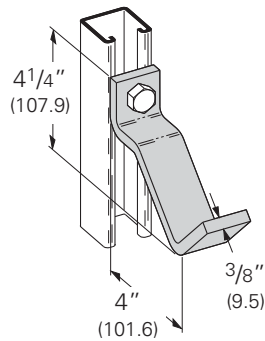

## B439 Pipe Support Bracket

- Standard finishes: ZN, GRN
- Wt./C 88 Lbs. (39.9 kg)

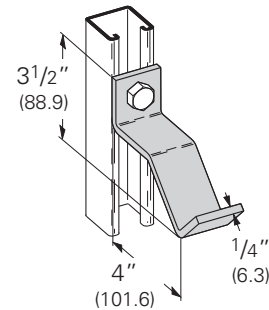

## B411 Series Ladder Rungs

- Standard finishes: ZN, GRN

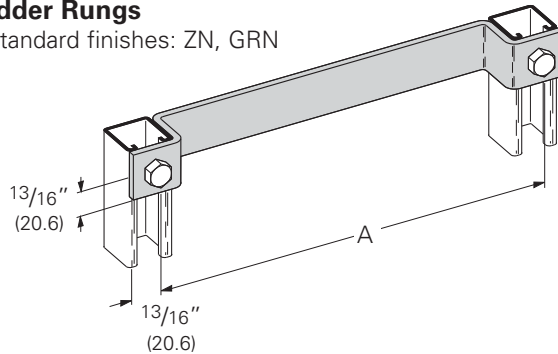

Part No.	A		Wt./C	
	In.	mm	Lbs.	kg
B411-12	12"	(304.8)	176	(79.8)
B411-15	15"	(381.0)	202	(91.6)
B411-18	18"	(457.2)	234	(106.1)

## B381-B385 Wall Ladder Brackets

- Standard finishes: ZN, GRN

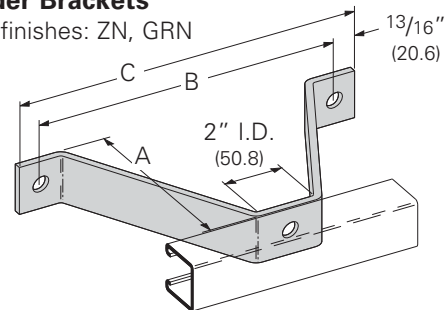

Part No.	A		B		C		Wt./C	
	In.	mm	In.	mm	In.	mm	Lbs.	kg
B381	2 <sup>3</sup> / <sub>8</sub> "	(60.3)	6"	(152.4)	7 <sup>5</sup> / <sub>8</sub> "	(193.7)	110	(49.9)
B382	4 <sup>3</sup> / <sub>8</sub> "	(111.1)	8"	(203.2)	9 <sup>5</sup> / <sub>8</sub> "	(244.5)	164	(74.4)
B383	6 <sup>3</sup> / <sub>8</sub> "	(161.9)	10"	(254.0)	11 <sup>5</sup> / <sub>8</sub> "	(295.3)	200	(90.7)
B384	8 <sup>3</sup> / <sub>8</sub> "	(212.7)	12"	(304.8)	13 <sup>5</sup> / <sub>8</sub> "	(346.1)	253	(114.7)
B385	10 <sup>3</sup> / <sub>8</sub> "	(263.5)	14"	(355.6)	15 <sup>5</sup> / <sub>8</sub> "	(396.9)	318	(144.2)

## B587-1/2, 3/4 & 1 Pipe Coupling Fitting

- Safety Factor of 2.5
- Standard finishes: ZN, GRN

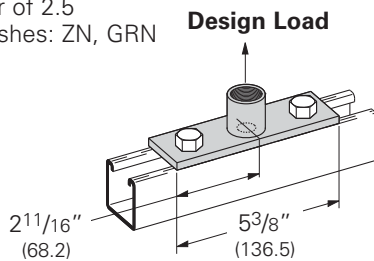

Part No.	For Pipe Size		Wt./C		Design Load
	In.	mm	Lbs.	kg	Lbs. kN
B587-1/2	1/2"	(15)	77	(34.9)	1000 (4.45)
B587-3/4	3/4"	(20)	84	(38.1)	1400 (6.23)
B587-1	1"	(25)	105	(47.6)	1900 (8.45)

4Dimension compatible fitting

Reference page 106 for general fitting and standard finish specifications.

# Miscellaneous Fittings

## B349 Trolley Beam Support

- Design Load 1200 Lbs. (5.34 kN)
- Safety Factor of 2.5
- Use  $\frac{3}{8}$ " x 3" bolts in side hole to clamp strut together (not included)
- Standard finishes: ZN, GRN
- Wt./C 107 Lbs. (48.5 kg)

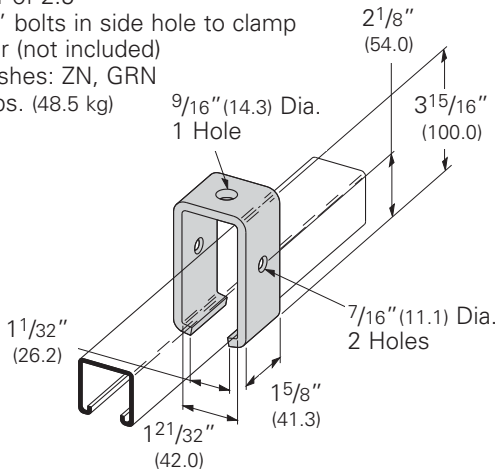

## B350 Trolley Beam Joint Support

- Design Load 1200 Lbs. (5.34 kN)
- Use  $\frac{3}{8}$ " x 3" bolts in side hole to clamp strut together (not included)
- Standard finishes: ZN, GRN
- Wt./C 233 Lbs. (105.7 kg)

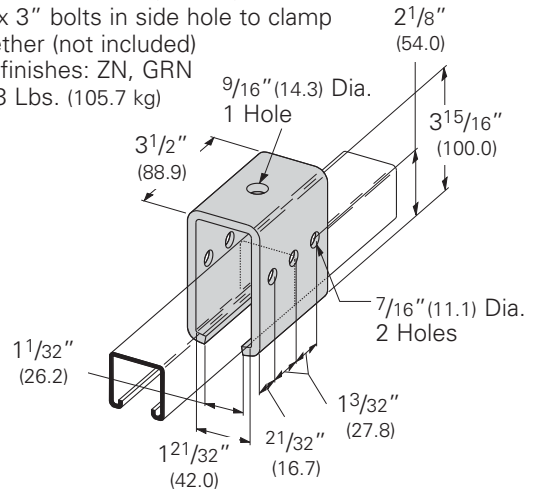

## B614 Column Support for B22

- Quick installation (one bolt to tighten)
- Design Load 800 Lbs. (3.56 kN) Slip with Safety Factor of 3
- Use with B22 and B24 Channel
- Sold in pairs
- Standard finish: ZN
- Wt./C 50 Lbs. (22.6 kg)

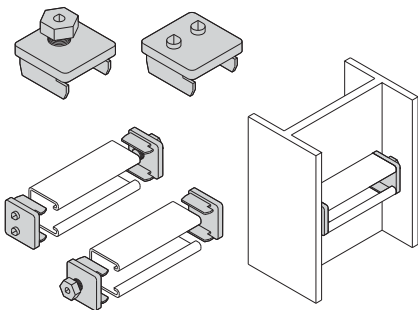

## B613 Column Support for B22

- Design Load 800 Lbs. (3.56 kN) Slip with Safety Factor of 3
- Use with B22 and B24 Channel
- Setscrews to be torqued to 19 ft./Lbs
- Sold in pairs
- Standard finishes: ZN, GRN, HDG
- Wt./C 100 Lbs. (45.3 kg)

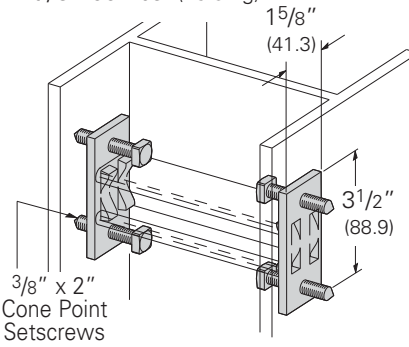

## B613A Column Support for B52

- Design Load 800 Lbs. (3.56 kN) Slip with Safety Factor of 3
- Use with B52 and B54 Channel
- Setscrews to be torqued to 19 ft./Lbs
- Sold in pairs
- Standard finishes: ZN, GRN, HDG
- Wt./C 100 Lbs. (45.3 kg)

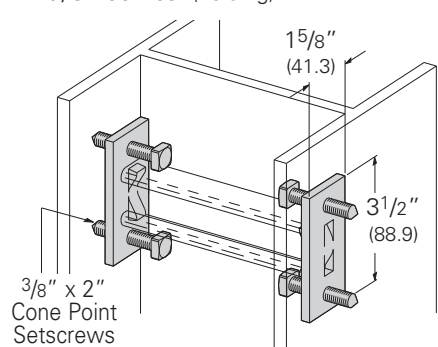

## B560 45° Stair Support

- Standard finishes: ZN, GRN
- Wt./C 220 Lbs. (99.8 kg)

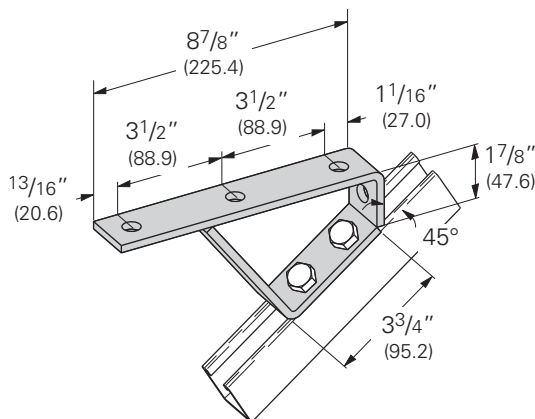

## B562 37 1/2° Stair Support

- Standard finishes: ZN, GRN
- Wt./C 206 Lbs. (93.4 kg)

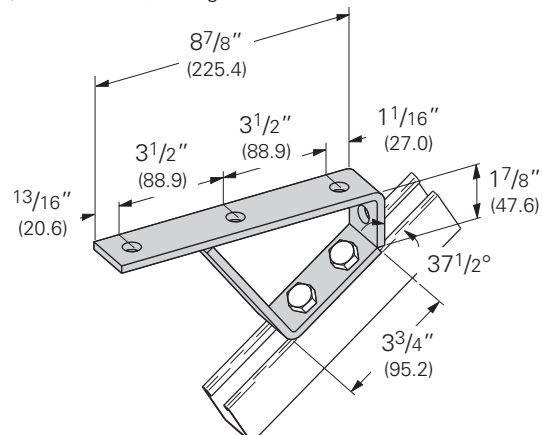

Reference page 106 for general fitting and standard finish specifications.

## B376 Four Bearing Trolley Assembly

- Safety Factor of 2.5
- Stainless steel ball bearings
- Not for continuous cycling applications
- Standard finishes: ZN
- Wt./C 110 Lbs. (49.9 kg)

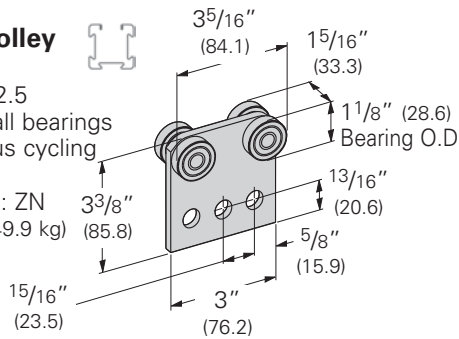

Design Load in B22		
Lbs.	kN	RPM
300	(1.33)	@600
450	(2.00)	@300
600	(2.67)	@100

Design Load

## B377 Two Bearing Trolley Assembly

- Safety Factor of 2.5
- Stainless steel ball bearings
- Not for continuous cycling applications
- Standard finishes: ZN
- Wt./C 48 Lbs. (21.8 kg)

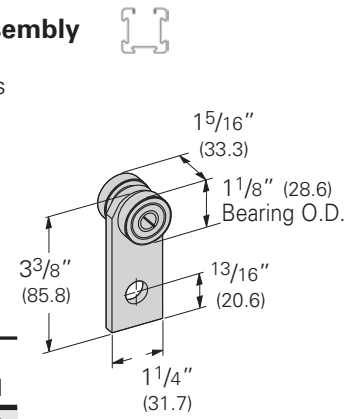

Design Load in B22		
Lbs.	kN	RPM
150	(.67)	@600
225	(1.00)	@300
437	(1.94)	@100

Design Load

## B477 Two Bearing Light Duty Trolley Assembly

- Design Load 50 Lbs. (.22 kN)
- Safety Factor of 2.5
- Stainless steel ball bearings
- Not for continuous cycling applications
- Material: 12 Gauge (2.6) ASTM A1011 33,000 PSI min. yield
- Standard finishes: ZN
- Wt./C 30 Lbs. (13.6 kg)

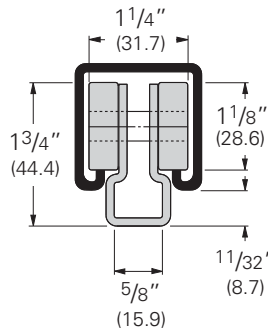

## B477P With Plastic Bearings

- Design Load 10 Lbs. (.045 kN)

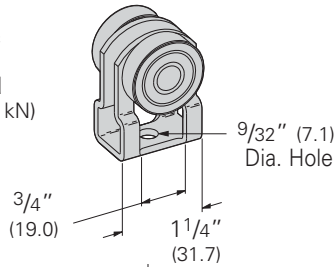

Design Load

## B478 Four Bearing Light Duty Trolley Assembly

- Design Load 100 Lbs. (.44 kN)
- Safety Factor of 2.5
- Stainless steel ball bearings
- Not for continuous cycling applications
- Material: 12 Gauge (2.6) ASTM A1011 33,000 PSI min. yield
- Standard finishes: ZN
- Wt./C 68 Lbs. (30.8 kg)

## B478P With Plastic Bearings

- Design Load 20 Lbs. (.090 kN)

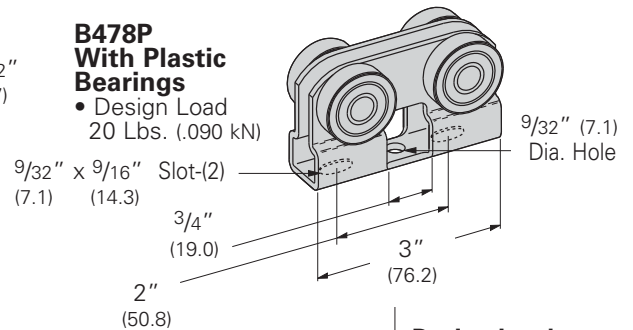

Design Load

## B477H Two Bearing Light Duty Trolley Assembly with Eye Hook

- Design Load 50 Lbs. (.22 kN)
- Safety Factor of 2.5
- Stainless steel ball bearings
- Not for continuous cycling applications
- Material: 12 Gauge (2.6) ASTM A1011 33,000 PSI min. yield
- Standard finishes: ZN
- Wt./C 36 Lbs. (16.3 kg)

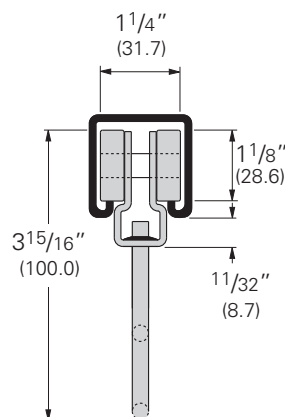

## B477HP With Plastic Bearings

- Design Load 10 Lbs. (.045 kN)

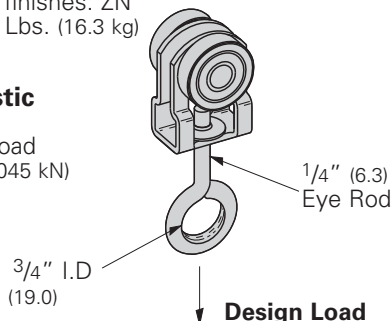

Design Load

## B478H Four Bearing Light Duty Trolley Assembly with Eye Hook

- Design Load 100 Lbs. (.44 kN)
- Safety Factor of 2.5
- Stainless steel ball bearings
- Not for continuous cycling applications
- Material: 12 Gauge (2.6) ASTM A1011 33,000 PSI min. yield
- Standard finishes: ZN
- Wt./C 72 Lbs. (32.6 kg)

## B478HP With Plastic Bearings

- Design Load 20 Lbs. (.090 kN)

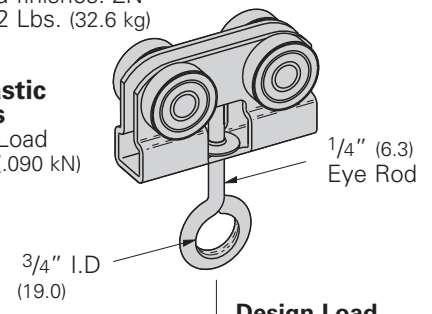

Design Load

4Dimension compatible fitting

Reference page 106 for general fitting and standard finish specifications.

# Miscellaneous Fittings

## B203-B206 & B220-B223 Channel End Caps Type X

- Material: ASTM A1011 CS Type B
- Standard finishes: ZN, GRN, HDG, SS4, AL

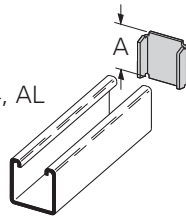

Part No.	Use With	A		Wt./C	
		In.	mm	Lbs.	kg
B203	B42	1.015	(25.8)	6	(2.7)
B204	B54	.827	(21.0)	5	(2.2)
B205	B22	1.640	(41.6)	10	(4.5)
B206	B32	1.390	(35.3)	8	(3.6)
B220	B52	.827	(21.0)	4	(1.8)
B221	B12	2.452	(62.3)	15	(6.8)
B222	B11	3.265	(82.9)	20	(9.1)
B223	B24	1.640	(41.6)	10	(4.5)

## B283-B286 Channel End Caps

- Material: ASTM A1011 33,000 PSI min. yield
- Standard finishes: ZN, GRN

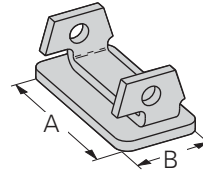

Part No.	Use With	A		B		Wt./C	
		In.	mm	In.	mm	Lbs.	kg
B283	B52	1 <sup>19</sup> / <sub>32</sub> "	(40.5)	2 <sup>5</sup> / <sub>32</sub> "	(19.8)	6	(2.7)
B284	B54 & B56	1 <sup>19</sup> / <sub>32</sub> "	(40.5)	2 <sup>5</sup> / <sub>32</sub> "	(19.8)	6	(2.7)
B285	B22	1 <sup>19</sup> / <sub>32</sub> "	(40.5)	1 <sup>19</sup> / <sub>32</sub> "	(40.5)	13	(5.9)
B286	B24 & B26	1 <sup>19</sup> / <sub>32</sub> "	(40.5)	1 <sup>19</sup> / <sub>32</sub> "	(40.5)	14	(6.3)

## B287 & B288 Channel End Caps

- Material: ASTM A1011 33,000 PSI min. yield
- Standard finishes: ZN, GRN

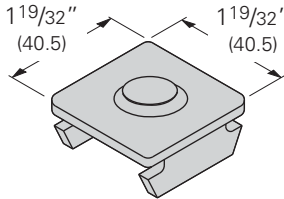

Part No.	Use With	Wt./C	
		Lbs.	kg
B287	B22	13	(5.9)
B288	B24	14	(6.3)

## B3322, B3332, B3342, B3352 Anchor End Caps Type Y

- Material: ASTM A1011 33,000 PSI min. yield
- Standard finishes: ZN

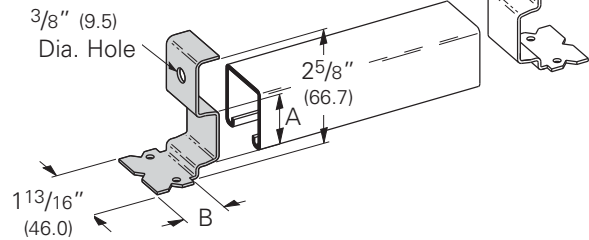

Part No.	Use With	A		B		Wt./C	
		In.	mm	In.	mm	Lbs.	kg
B3322	B22	1.270	(32.2)	1 <sup>3</sup> / <sub>16</sub> "	(30.2)	15	(6.8)
B3332	B32	1.000	(25.4)	1 <sup>3</sup> / <sub>16</sub> "	(30.2)	15	(6.8)
B3342	B42	.645	(16.4)	1 <sup>1</sup> / <sub>4</sub> "	(31.8)	15	(6.8)
B3352	B52	.460	(11.7)	1 <sup>5</sup> / <sub>16</sub> "	(33.3)	15	(6.8)

## B822 Plastic End Cap for B22 & B24

- Material: Polyvinyl Chloride (PVC/Vinyl)
- Withstands intermittent temperatures up to 350°F (177°C) and 200°F (93°C) continuous
- Wt./C 3 Lbs. (1.3 kg)
- Available in colors: White (W), Yellow (Y), Black (BLK), Gray (GRY), Green (GRN)

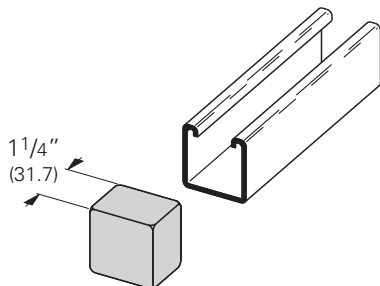

## B822A Plastic End Cap for B22A & B11

- Material: Polyvinyl Chloride (PVC/Vinyl)
- Withstands intermittent temperatures up to 350°F (177°C) and 200°F (93°C) continuous
- Wt./C 5 Lbs. (2.2 kg)
- Available in colors: White (W), Yellow (Y), Black (BLK), Gray (GRY), Green (GRN)

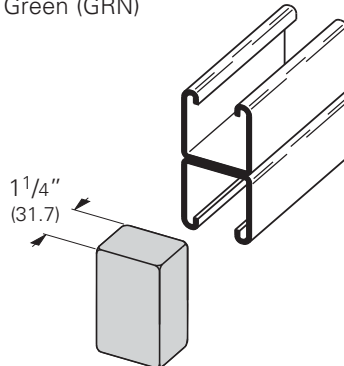

## B852 Plastic End Cap for B52

- Material: Polyvinyl Chloride (PVC/Vinyl)
- Withstands intermittent temperatures up to 350°F (177°C) and 200°F (93°C) continuous
- Wt./C 2.5 Lbs. (1.1 kg)
- Available in colors: White (W), Yellow (Y), Black (BLK), Gray (GRY), Green (GRN)

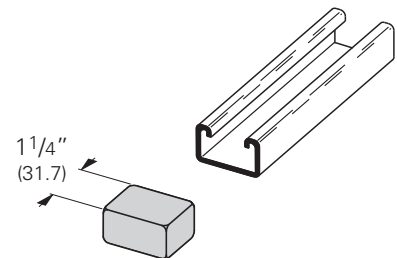

Reference page 106 for general fitting and standard finish specifications.

## B823 Profile End Caps

- Material: Polyvinyl Chloride (PVC/Vinyl)
- Withstands intermittent temperatures up to 350°F (177°C) and 200°F (93°C) continuous
- Available in colors: White (W), Yellow (Y), Black (BLK), Gray (GRY), Green (GRN)

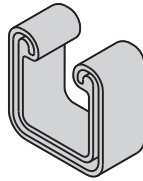

Approx. 3/4" deep  
(19.0)

Part No.	Fits Channel Sizes	Wt./C	
		Lbs.	kg
<b>B823-22A</b>	B22A, B24A, B26A	6.9	(3.1)
<b>B823-22</b>	B22, B24, B26	4.1	(1.8)
<b>B823-42</b>	B42	3.8	(1.7)
<b>B823-52</b>	B52, B54, B56	3.5	(1.6)

## B825 Plastic End Caps

- Material: Polyurethane
- Available in colors: Gray (GRY), Green (GRN)

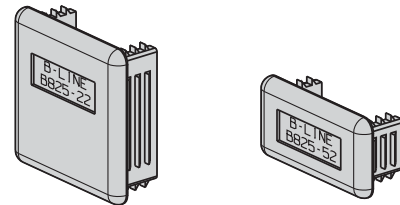

Part No.	Fits Channel Sizes	Wt./C	
		Lbs.	kg
<b>B825-22</b>	B22 & B24	2.0	(0.9)
<b>B825-52</b>	B52 & B54	1.0	(0.4)

## B408SLBVNS Series Stand-Off Brackets

- Material: 1/4" (6.3)
- Standard Finishes: HDG, ZN, GRN
- For pipe or rigid conduit sizes of 1 1/2" (40) and 2" (50) use with B501 Series 'U'-Bolts (see page 53)
- For strut channels 1 5/8" (41.3) wide use with B500 Series Square 'U'-Bolts (see page 53)
- Hardware is not included

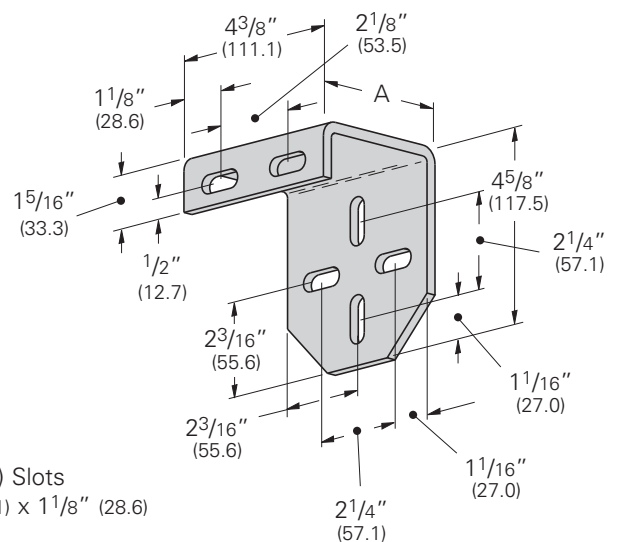
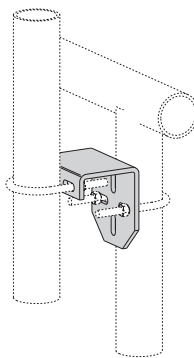

Part No.	A In. (mm)	Wt./C	
		Lbs.	kg
<b>B408SLBVNS</b>	3 1/2" (88.9)	189	(85.7)
<b>B408SLBVNS1</b>	3" (76.2)	220	(99.8)
<b>B408SLBVNS2</b>	2" (50.8)	236	(107.0)

Reference page 106 for general fitting and standard finish specifications.