

Electrical Accessories



A complete system of top quality, time saving products, designed for surface metal raceways, lighting and cable supports. Innovative designs offer many installation advantages. The surface raceways are U.L. listed and meet the requirements of the National Electrical Code, Article 384.

Surface Raceways

Our channel provides structural support in addition to a raceway system.

For U.L. wire fill see chart on page 278-279.

Cable Supports

A full range of clamps and saddles are offered in porcelain and thermoplastic elastomer. Our Insulclamp™ cable clamps and porcelain saddles are furnished complete with steel clamps (electro-plated) and Everdur hardware where required.

Materials & Finishes*

Steel products are made from low carbon steel strips or plates. Porcelain saddles and clamps are made by dry process and white glazed (porcelain dielectric strength is 50 volts per mil).

*Unless otherwise noted.

Finish Code	Finish	Specification
PLN	Plain	ASTM A1011 33,000 PSI min. yield
ZN	Electro-Plated Zinc	ASTM B633 SC3 Type III
GRN	DURA GREEN™	
GALV	Pre-Galvanized	ASTM A653
YZN	Yellow Zinc Chromate	ASTM B633 SC3 Type II

Design Load

Design load data published includes a Safety Factor of 3.0 (Safety Factor = Ratio of ultimate load to the design load).

U.L. listed raceway channels:

B11, B11KO6	B32, B32KO6
B12, B12KO6	B42, B42KO6
B22, B22KO6	B52, B52KO6
B24, B24KO6	B54, B54KO6
B26, B26KO6	B56, B56KO6

U.L. File No. E29637

In all cases, the snap-in closure strip is required to complete raceway enclosure.

Metric

Metric dimensions are shown in parentheses. Unless noted, all metric dimensions are in millimeters.

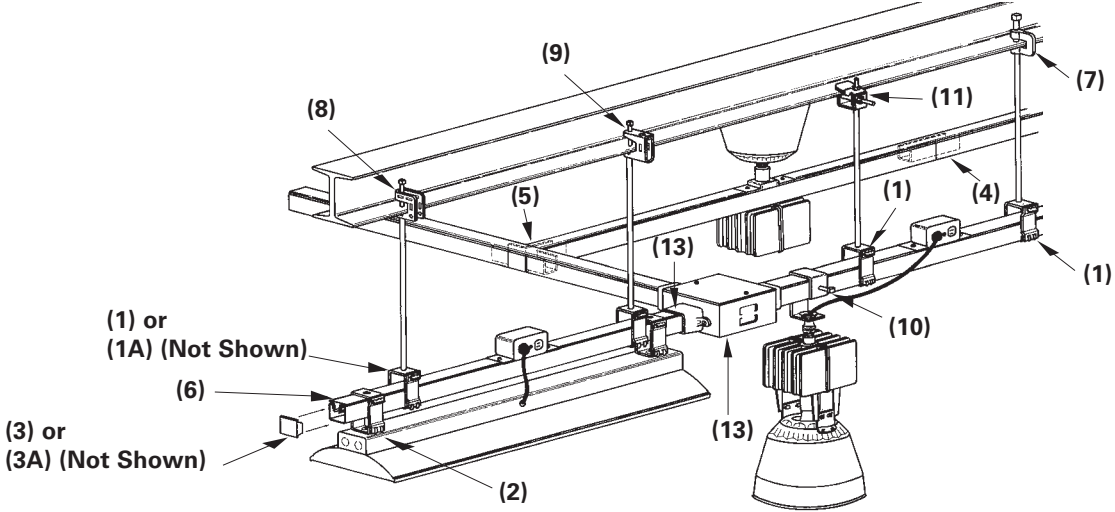

Selection Chart

Channel Number	Depth in. mm	1 Channel Hanger	1A Channel Hanger	2 Fixture Hanger	3 End Cap	3A Connection End Cap	4 Internal Straight Splice	5 Internal Tee Splice
B22A	3 ¹ / ₄ " (82.5)	B616-22A*	B241S*	B616S-22A*	B205 or B285	B392-22**	B766-22 (2) B285	B768-22 (2)
B11	3 ¹ / ₄ " (82.5)	B616-22A*	B241S*	B616S-22A*	B222	B392-11**	B766-11	B768-11
B12	2 ⁷ / ₁₆ " (61.9)	B616-22A*	B241S*	B616S-22A*	B221	B392-12**	B766-12	B768-12
B22 B24	1 ⁵ / ₈ " (41.3)	B616*	B216S*	B616S* B616TG*	B205 or B285 B223 or B286	B392-22**	B766-22	B768-22
B26	1 ⁵ / ₈ " (41.3)	B616*	-	-	-	B392-22**	-	-
B32	1 ³ / ₈ " (34.9)	B616*	B216S*	B616S* B616TG*	B206	B392-32**	B766-32	B768-32
B42	1" (25.4)	B616*	B215S*	B616S* B616TG*	B203	-	B766-42	B768-42
B52 B54	1 ³ / ₁₆ " (20.6)	B616*	B215S*	B616S* B616TG*	B220 or B283 B204 or B284	-	B766-52	B768-52
B56	1 ³ / ₁₆ " (20.6)	B616*	B215S*	B616S* B616TG*	-	-	B766-56	-

*Specify Hanger Rod or Conduit Size.

**Specify Conduit Size

Other Items Shown on Illustration

B217-20 Snap-in Closure Strip	B351L Beam Clamp	B755 Beam Clamp	B751 Beam Clamp
B465 H.I.D. Fixture Hanger	B750 Beam Clamp	B447 B447A Conduit Connection Plate	B719 B718 Series Junction Box

Reference page 206 for general fitting and standard finish specifications. U.L. Wire Fill Chart on pages 272 - 273.

Fluorescent Fixture Hangers

B616-9/16 Channel Hanger

- Design Load 250 Lbs. (1.11 kN)
- Safety Factor of 3
- Maximum design load 50 Lbs. (.22 kN) when used as a fixture support
- Includes:
2 pcs. $\frac{3}{8}$ " Flat washers for use with $\frac{3}{8}$ " ATR
- Material: 16 gauge (1.5)
- Standard finish: ZN
- Wt./C 25 Lbs. (11.3 kg)

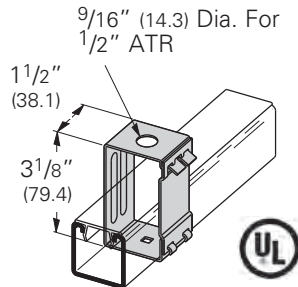

B616-7/8 Channel Hanger

- Design Load 250 Lbs. (1.11 kN)
- Safety Factor of 3
- Maximum design load 50 Lbs. (.22 kN) when used as a fixture support
- Material: 16 gauge (1.5)
- Standard finish: ZN
- Wt./C 25 Lbs. (11.3 kg)

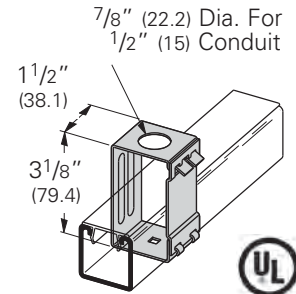

B616S-9/16 Fluorescent Fixture Hanger with Stud

- Design Load 150 Lbs. (.67 kN)
- Safety Factor of 3
- Maximum design load 50 Lbs. (.22 kN) when used as a fixture support
- Allows more than $\frac{1}{2}$ " (12.7) space between channel and fixture
- Includes:
2 pcs. $\frac{3}{8}$ " Flat washers for use with $\frac{3}{8}$ " ATR
- Material: 16 gauge (1.5)
- Standard finish: ZN
- Wt./C 30 Lbs. (13.6 kg)

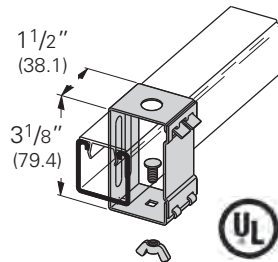

B616S-7/8 Fluorescent Fixture Hanger with Stud

- Design Load 150 Lbs. (.67 kN)
- Safety Factor of 3
- Maximum design load 50 Lbs. (.22 kN) when used as a fixture support
- Allows more than $\frac{1}{2}$ " (12.7) space between channel and fixture
- Standard finish: ZN
- Material: 16 gauge (1.5)
- Wt./C 30 Lbs. (13.6 kg)

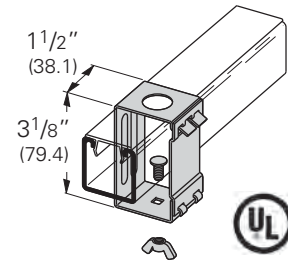

B616-22A-9/16 Channel Hanger

- Design Load 250 Lbs. (1.11 kN)
- Safety Factor of 3
- Maximum design load 50 Lbs. (.22 kN) when used as a fixture support
- Includes:
2 pcs. $\frac{3}{8}$ " Flat washers for use with $\frac{3}{8}$ " ATR
- Material: 14 gauge (1.9)
- Standard finish: ZN
- Wt./C 44 Lbs. (19.9 kg)

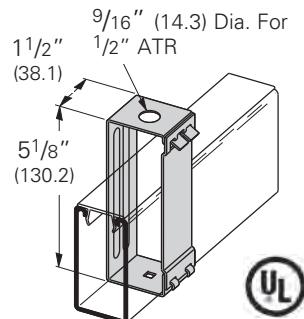

B616-22A-7/8 Channel Hanger

- Design Load 250 Lbs. (1.11 kN)
- Safety Factor of 3
- Maximum design load 50 Lbs. (.22 kN) when used as a fixture support
- Material: 14 gauge (1.9)
- Standard finish: ZN
- Wt./C 44 Lbs. (19.9 kg)

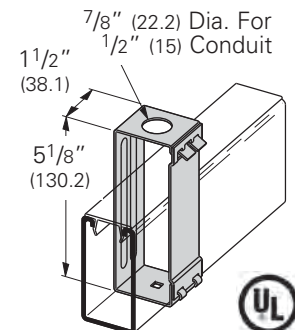

Reference page 206 for general fitting and standard finish specifications. U.L. Wire Fill Chart on pages 272 - 273.

Fluorescent Fixture Hangers

B616S-22A-9/16 Fluorescent Fixture Hanger with Stud

- Design Load 150 Lbs. (.67 kN)
- Safety Factor of 3
- Maximum design load 50 Lbs. (.22 kN) when used as a fixture support
- Includes:
 - 2 pcs. $\frac{3}{8}$ " Flat washers for use with $\frac{3}{8}$ " ATR
- Allows more than $\frac{1}{2}$ " (12.7) space between channel and fixture
- Material: 14 gauge (1.9)
- Standard finish: ZN
- Wt./C 49 Lbs. (22.2 kg)

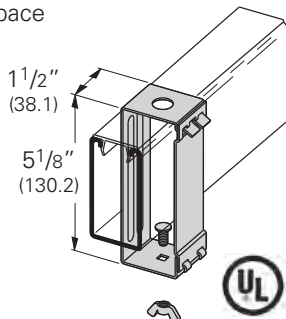

B616S-22A-7/8 Fluorescent Fixture Hanger with Stud

- Design Load 150 Lbs. (.67 kN)
- Safety Factor of 3
- Maximum design load 50 Lbs. (.22 kN) when used as a fixture support
- Allows more than $\frac{1}{2}$ " (12.7) space between channel and fixture
- Material: 14 gauge (1.9)
- Standard finish: ZN
- Wt./C 49 Lbs. (22.2 kg)

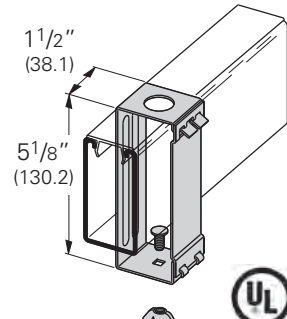

B616TG-9/16 Fluorescent Fixture Hanger for 1/2" (15) Knockout

- Design Load 150 Lbs. (.67 kN)
- Safety Factor of 3
- Maximum design load 50 Lbs. (.22 kN) when used as a fixture support
- Includes:
 - 2 pcs. $\frac{3}{8}$ " Flat washers for use with $\frac{3}{8}$ " ATR
- Design Load 150 Lbs. (.67 kN)
- Allows more than $\frac{1}{2}$ " (12.7) space between channel and fixture
- Material: 16 gauge (1.5)
- Standard finish: ZN
- Wt./C 32 Lbs. (14.5 kg)

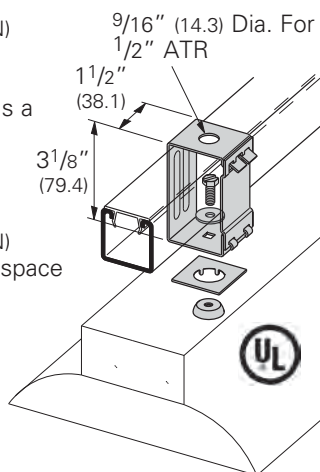

B215S Channel Hanger

- Can be used with $\frac{3}{8}$ " & $\frac{1}{2}$ " threaded rod or $\frac{3}{8}$ " & $\frac{1}{2}$ " conduit
- Design Load 250 Lbs. (1.11 kN)
- Safety Factor of 3
- For use with B42, B52, B54 & B56 channels
- Hardware included:
 - One (1) $\frac{3}{8}$ " x $1\frac{1}{2}$ " FFW for use with $\frac{3}{8}$ "-16 ATR
 - One (1) $\frac{1}{2}$ " FW for use with $\frac{1}{2}$ "-13 ATR
 - One (1) $\frac{5}{8}$ " FW for use with $\frac{3}{8}$ " conduit
- Material: 16 gauge (1.5)
- Standard finish: ZN
- Wt./C 31 Lbs. (14.0 kg)

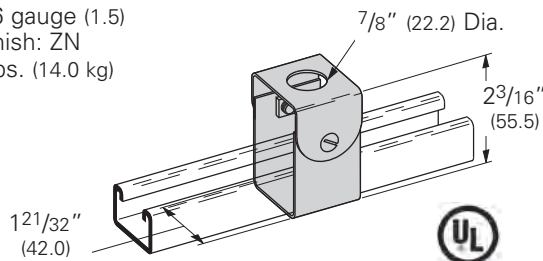

B216S Channel Hanger

- Can be used with $\frac{3}{8}$ " & $\frac{1}{2}$ " threaded rod or $\frac{3}{8}$ " & $\frac{1}{2}$ " conduit
- Design Load 250 Lbs. (1.11 kN)
- Safety Factor of 3
- For use with B22, B24, B26 & B32 channels
- Hardware included:
 - One (1) $\frac{3}{8}$ " x $1\frac{1}{2}$ " FFW for use with $\frac{3}{8}$ "-16 ATR
 - One (1) $\frac{1}{2}$ " FW for use with $\frac{1}{2}$ "-13 ATR
 - One (1) $\frac{5}{8}$ " FW for use with $\frac{3}{8}$ " conduit
- Material: 16 gauge (1.5)
- Standard finish: ZN
- Wt./C 38 Lbs. (17.2 kg)

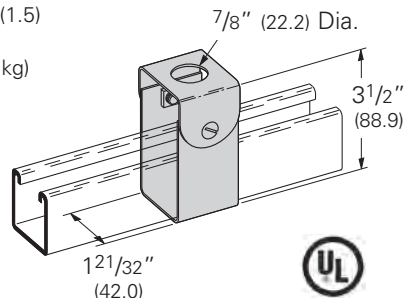

B241S Channel Hanger

- Can be used with $\frac{3}{8}$ " & $\frac{1}{2}$ " threaded rod or $\frac{3}{8}$ " & $\frac{1}{2}$ " conduit
- Design Load 250 Lbs. (1.11 kN)
- Safety Factor of 3
- For use with B11 & B12 channels
- Hardware included:
 - One (1) $\frac{3}{8}$ " x $1\frac{1}{2}$ " FFW for use with $\frac{3}{8}$ "-16 ATR
 - One (1) $\frac{1}{2}$ " FW for use with $\frac{1}{2}$ "-13 ATR
 - One (1) $\frac{5}{8}$ " FW for use with $\frac{3}{8}$ " conduit
- Material: 16 gauge (1.5)
- Standard finish: ZN
- Wt./C 47 Lbs. (21.3 kg)

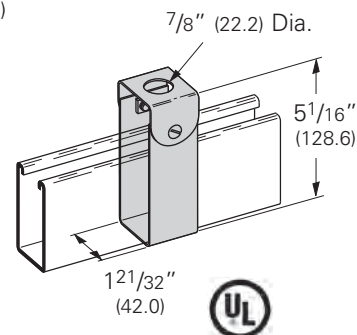

Reference page 206 for general fitting and standard finish specifications. U.L. Wire Fill Chart on pages 272 - 273.

Fluorescent Fixture Hangers

B390S 360° Swivel Channel Connector

- Design Load 250 Lbs. (1.11 kN)
- Safety Factor of 3
- Maximum design load 50 Lbs. (.22 kN) when used as a fixture support
- Swings 15° in 360° plane
- Includes:
 - 2 pcs. SN224-3/4"WO Stud nut
 - 2 pcs. 1/4"-20 Square nut
 - 1 pc. 3/4" (20) to 1/2" (15) Conduit Reducer
- Standard finish: ZN
- Wt./C 71 Lbs. (32.2 kg)

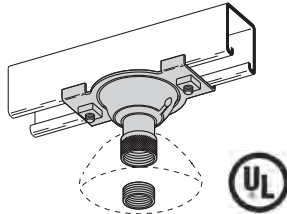

B390BX 360° Swivel Box Connector

- Design Load 250 Lbs. (1.11 kN) for connector fitting only
- Safety Factor of 3
- Design Load 50 Lbs. (.22 kN) when used as illustrated or for use as a fixture support
- Swings 15° in 360° plane
- Includes:
 - 1 pc. 3/4" (20) to 1/2" (15) Conduit reducer
- Fits on 4" box
- Standard finish: ZN
- Wt./C 55 Lbs. (24.9 kg)

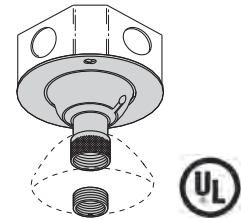

B465 H.I.D. Fixture Hanger

- Design Load 250 Lbs. (1.11 kN)
- Safety Factor of 3
- Swings 15° in 360° plane
- Includes:
 - 1 pc. 3/4" (20) to 1/2" (15) Conduit reducer
- Standard finish: ZN
- Wt./C 95 Lbs. (43.1 kg)

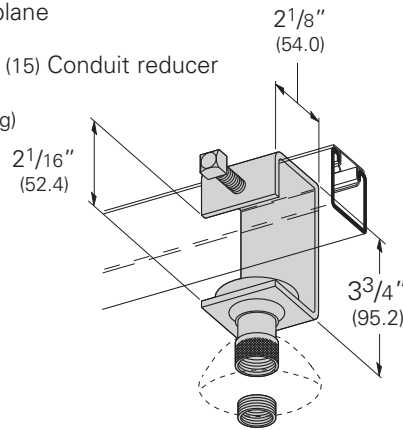

B436 Fluorescent Fixture Nut

- Standard finish: ZN
- Wt./C 2 Lbs. (.9 kg)

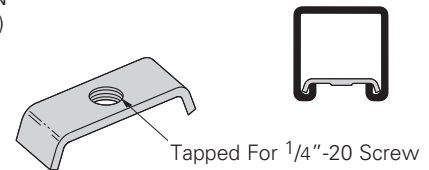

B436S Fluorescent Fixture Stud Nut

- Bolt size: 1/4" x 1 1/4"
- Standard finish: ZN
- Wt./C 4 Lbs. (1.8 kg)
- Design Load 250 Lbs. (1.11 kN)
- Safety Factor of 3

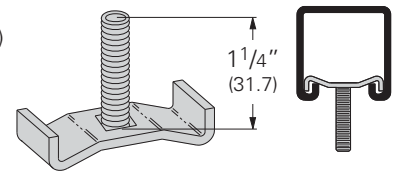

B460 Fluorescent Fixture Hanger

- Hanger is shipped flat and requires field bending as shown
 - Allows more than 1/2" (12.7) space between channel and fixture
 - Material: 18 gauge (1.2)
 - Standard finish: ZN
- 1/4" x 1" Round Head Machine Screw and Square Nut Included

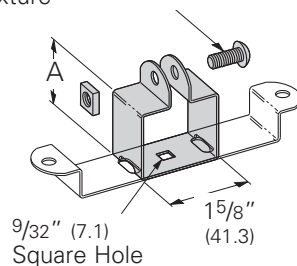

B464 Fluorescent Fixture Hanger

- Hanger is shipped flat and requires field bending as shown
 - Allows more than 1/8" (3.2) space between channel and fixture
 - Material: 18 gauge (1.2)
 - Standard finish: ZN
- 1/4" x 1" Round Head Machine Screw and Square Nut Included

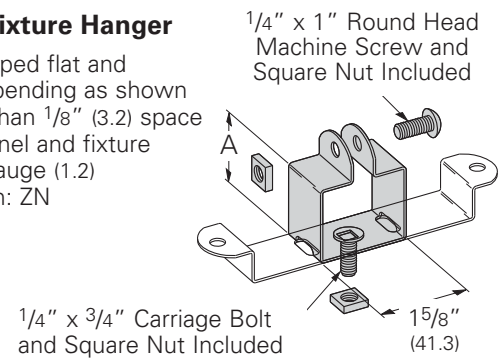

Part No.	For Channel Size	A		Wt./C	
		In.	mm	Lbs.	kg
B460-22	B22, B24, B26, B32	2 1/8"	(57.5)	17	(7.7)
B460-12	B12	2 15/16"	(79.5)	20	(9.1)
B460-11	B11	3 3/4"	(101.6)	23	(10.4)

Part No.	For Channel Size	A		Wt./C	
		In.	mm	Lbs.	kg
B464-32	B32	1 1/2"	(40.6)	17	(7.7)
B464-22	B22, B24, B26	1 3/4"	(47.4)	18	(8.1)
B464-12	B12	2 9/16"	(66.0)	21	(9.5)
B464-11	B11	3 3/8"	(91.4)	24	(10.9)

Reference page 206 for general fitting and standard finish specifications. U.L. Wire Fill Chart on pages 272 - 273.

B217-20 Snap Closure Strip for All 1 5/8" (41.3) Wide Channels

- Refer to Raceway Fill Chart pages 278-279
- Material: 20 gauge (.9)
- Standard finishes: GRN, GALV, YZN
- Standard length: 120" (3.05m)
- Wt./CFT 36 Lbs. (16.3 kg)

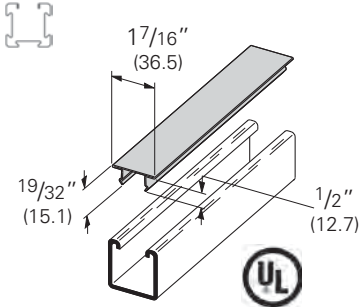

B217P Plastic Snap Closure Strip for All 1 5/8" (41.3) Wide Channels

- Refer to Raceway Fill Chart pages 278-279
- Standard finishes: Green (GRN) or Gray (GRY) Plastic
- Standard length: 120" (3.05m)
- Wt./CFT 9.2 Lbs. (4.2 kg)

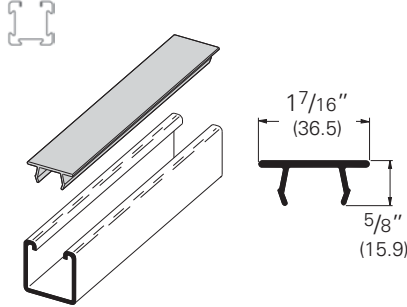

B217-24 Snap Closure Strip for All 1 5/8" (41.3) Wide Channels

- Refer to Raceway Fill Chart pages 278-279
- For use with 7 or fewer conductors no larger than #12 AWG
- Material: 24 gauge (.6)
- Standard finishes: GRN, GALV, YZN
- Standard length: 120" (3.05m)
- Wt./CFT 28 Lbs. (12.7 kg)

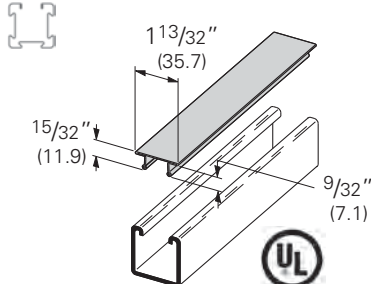

B516 Snap-In Outlet Box

- Provided with #10-32 tapped hole for grounding strap
- Duplex cover plate included
- Receptacle not furnished
- Requires ground wire installation for use with UL listed channel raceway system
- Standard finish: GALV
- Wt./C 72 Lbs. (32.6 kg)

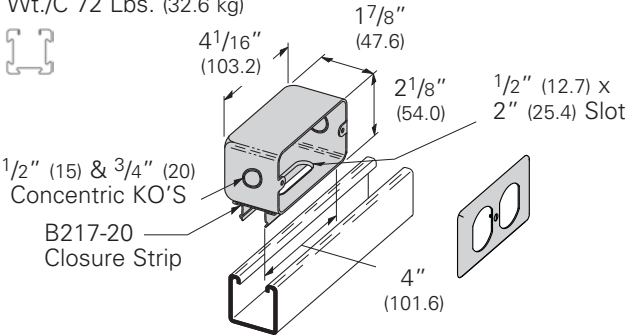

B516S Outlet Box

- Duplex cover plate included
- Receptacle not furnished
- Includes:
2 pcs. 1/4"-20 Flat head machine screws
2 pcs. N224WO Channel nuts
- Standard finish: GALV
- Wt./C 98 Lbs. (44.4 kg)

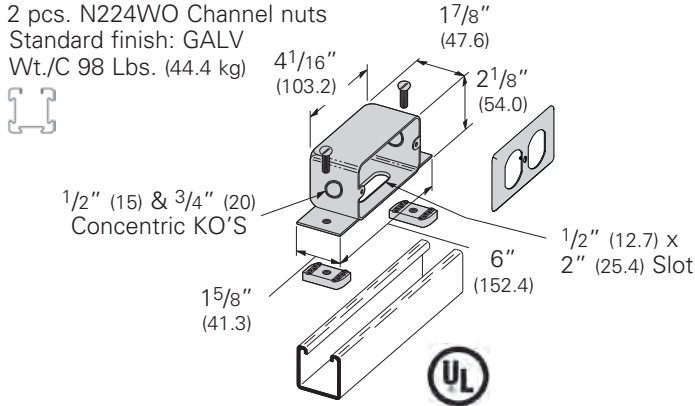

B203 thru B206 B220 thru B223 X Type End Caps

- Material: 12 gauge (2.6)
- Standard finishes: ZN, GRN, HDG, SS4

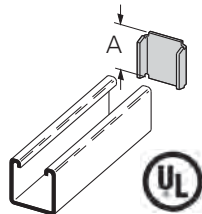

Part No.	Use With	A		Wt./C	
		In.	mm	Lbs.	kg
B203	B42	1.015"	(25.8)	6	(2.7)
B204	B54	.827"	(21.0)	5	(2.2)
B205	B22	1.640"	(41.6)	10	(4.5)
B206	B32	1.390"	(35.3)	8	(3.6)
B220	B52	.827"	(21.0)	4	(1.8)
B221	B12	2.452"	(62.3)	15	(6.8)
B222	B11	3.265"	(82.9)	20	(9.1)
B223	B24	1.640"	(41.6)	10	(4.5)

B283 thru B286 End Caps

- Material: 12 gauge (2.6)
- Standard finishes: ZN, GRN

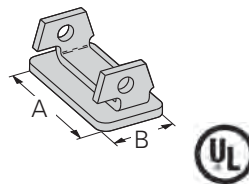

Part No.	Use With	A		B		Wt./C Lbs. kg
		In.	mm	In.	mm	
B283	B52	1 19/32"	(40.5)	25/32"	(19.8)	6 (2.7)
B284	B54 & B56	1 19/32"	(40.5)	25/32"	(19.8)	6 (2.7)
B285	B22	1 19/32"	(40.5)	1 19/32"	(40.5)	13 (5.9)
B286	B24 & B26	1 19/32"	(40.5)	1 19/32"	(40.5)	14 (6.3)

4Dimension compatible fitting

Reference page 206 for general fitting and standard finish specifications. U.L. Wire Fill Chart on pages 272 - 273.

Electrical Accessories

B447 Conduit Connection Plate for 1/2" (15) Conduit

- Includes:
 - 2 pcs. 1/4"-20 Flat head machine screws
 - 2 pcs. N224WO Channel nuts
- Material: 16 gauge (1.5)
- Standard finish: ZN
- Wt./C 35 Lbs. (15.9 kg)

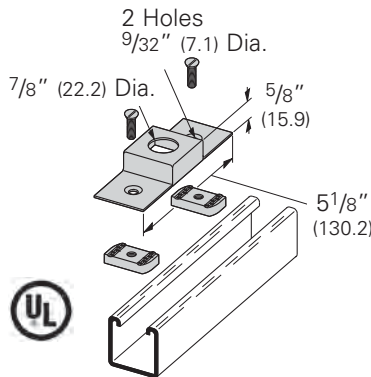

B447A Conduit Connection Plate for 3/4" (20) Conduit

- Includes:
 - 2 pcs. 1/4"-20 Flat head machine screws
 - 2 pcs. N224WO Channel nuts
- Material: 16 gauge (1.5)
- Standard finish: ZN
- Wt./C 35 Lbs. (15.9 kg)

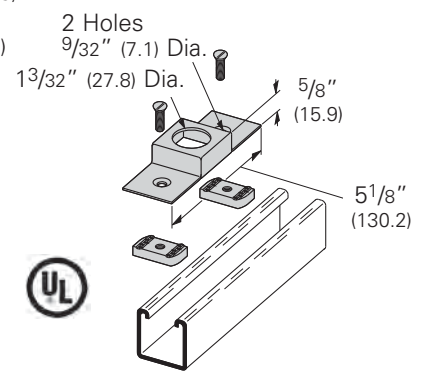

B392-32 Series Connection End Cap

- Includes:
 - 1 pc. 1/4"-20 Square nut
 - 1 pc. B436S Fixture stud nut
- Material: 11 gauge (3.0)
- Standard finish: ZN

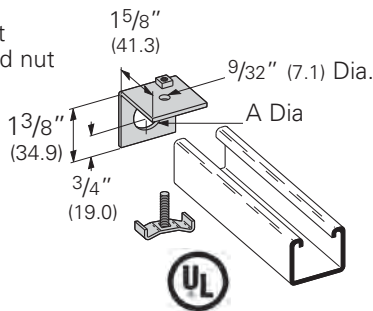

Part No.	A		Conduit Size		Wt./C	
	In.	mm	In.	mm	Lbs.	kg
B392-32-1/2	7/8"	(22.2)	1/2"	(15)	20	(9.1)
B392-32-3/4	1 1/16"	(27.0)	3/4"	(20)	19	(8.6)

B392-22 Series Connection End Cap

- Includes:
 - 1 pc. 1/4"-20 Square nut
 - 1 pc. B436S Fixture stud nut
- Material: 11 gauge (3.0)
- Standard finish: ZN

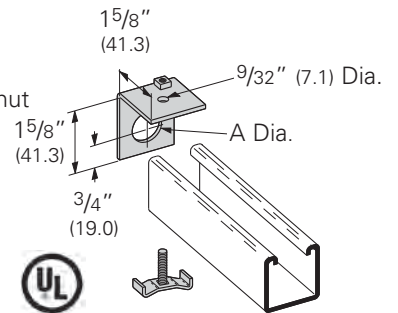

Part No.	A		Conduit Size		Wt./C	
	In.	mm	In.	mm	Lbs.	kg
B392-22-1/2	7/8"	(22.2)	1/2"	(15)	21	(9.5)
B392-22-3/4	1 1/16"	(27.0)	3/4"	(20)	20	(9.1)
B392-22-1	1" Pipe Thread		1"	(25)	17	(7.7)

B392-12 Series Connection End Cap

- Includes:
 - 1 pc. 1/4"-20 Square nut
 - 1 pc. B436S Fixture stud nut
- Material: 11 gauge (3.0)
- Standard finish: ZN

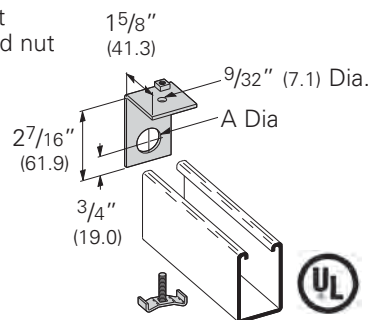

Part No.	A		Conduit Size		Wt./C	
	In.	mm	In.	mm	Lbs.	kg
B392-12-1/2	7/8"	(22.2)	1/2"	(15)	27	(12.2)
B392-12-3/4	1 1/16"	(27.0)	3/4"	(20)	26	(11.8)
B392-12-1	1" Pipe Thread		1"	(25)	23	(10.4)

B392-11 Series Connection End Cap

- Includes:
 - 1 pc. 1/4"-20 Square nut
 - 1 pc. B436S Fixture stud nut
- Material: 11 gauge (3.0)
- Standard finish: ZN

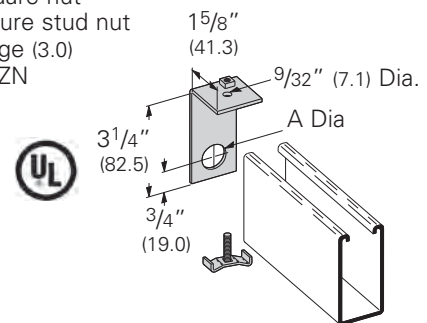

Part No.	A		Conduit Size		Wt./C	
	In.	mm	In.	mm	Lbs.	kg
B392-11-1/2	7/8"	(22.2)	1/2"	(15)	36	(16.3)
B392-11-3/4	1 1/16"	(27.0)	3/4"	(20)	33	(14.9)
B392-11-1	1" Pipe Thread		1"	(25)	32	(14.5)

Reference page 206 for general fitting and standard finish specifications. U.L. Wire Fill Chart on pages 272 - 273.

B718 Universal Junction Bob

- Assemble B719 Hubs into B718 square knockouts
- Designed for use with B22, B24 & B26 channel
- B718 Includes:
 - 1 pc. Junction box only
 - 1 pc. Cover only
 - 2 pcs. #10-20 Round head machine screws
- Standard finish: ZN
- Wt./C 180 Lbs. (81.6 kg)

Part No.	Includes	Wt./C	
		Lbs.	kg
B718-1	1 B718 & 1 B719	205	(93.0)
B718-2	1 B718 & 2 B719	230	(104.3)
B718-3	1 B718 & 3 B719	255	(115.6)
B718-4	1 B718 & 4 B719	280	(127.0)

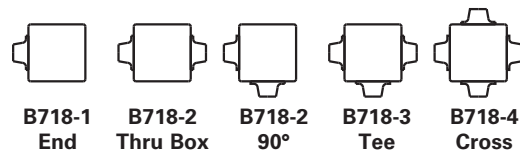

Selection Guide

Box Dimension:
2 1/2" (63.5 Deep x
5 1/8" (130.2) Square

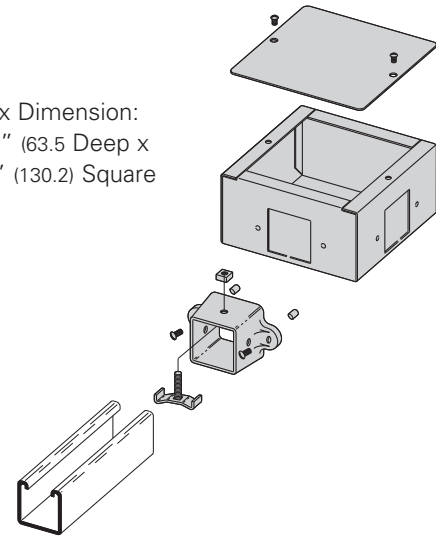

B719AL Universal Junction Box Hub

- B719AL Includes:
 - 1 pc. B719AL Hub only
 - 1 pc. B436S Fixture stud nut
 - 1 pc. 1/4"-20 Square nut
 - 2 pcs. #10-24 Self tapping ncrews
 - 2 pcs. Rubber caps
- Material: Aluminum
- Wt./C 25 Lbs. (11.3 kg)

B518-1 thru B518-4 Universal Junction Box & Hubs

- Channel connection kits as shown in the chart above
- Includes:
 - 1 pc. Junction box with screws
 - 1 pc. Box cover
- Standard finish: ZN

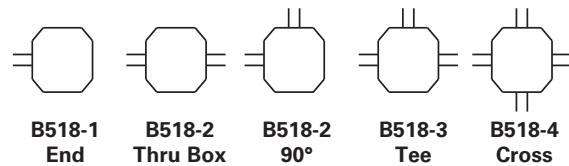

Selection Guide

Part No.	Channel Connection Kits Included	Wt./C	
		Lbs.	kg
B518-1	1	106	(48.1)
B518-2	2	137	(62.1)
B518-3	3	162	(78.5)
B518-4	4	192	(87.1)

Channel Connection Kit

- For use with B22, B24 & B26 channels.
- Box Dimension: Standard 4" octagon box
- Includes:
 - 1 pc. B392-22-3/4 End connection (See page 212)
 - 1 pc. 3/4" (20) Insulated chase nipple
 - 1 pc. 3/4" (20) Lock nut
- Standard finish: ZN

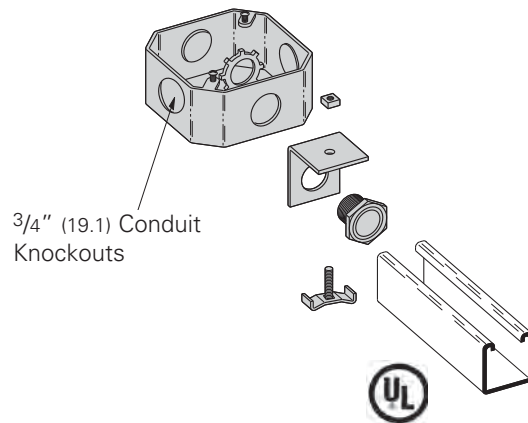

Reference page 206 for general fitting and standard finish specifications. U.L. Wire Fill Chart on pages 272 - 273.

Strut Joiners

B766 Series Straight Strut Joiner

- Includes: 2 Cam screws
- Material: 12 gauge (2.6)
- Standard finish: ZN

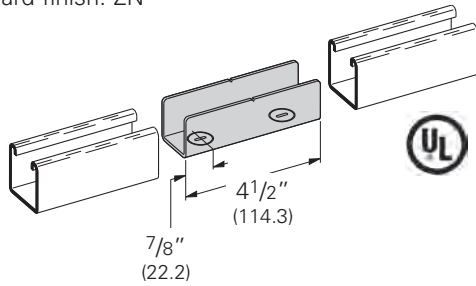

Part No.	For Channel Size	Wt./C	
		Lbs.	kg
B766-11	B11	94	(42.6)
B766-12	B12	72	(32.6)
B766-22 *	B22 & B24	50	(22.7)
B766-26	B26	53	(24.0)
B766-32	B32	44	(19.9)
B766-42	B42	34	(15.4)
B766-52	B52 & B54	28	(12.7)
B766-56	B56	31	(14.0)

* Cast aluminum parts

B767 Series 90° Elbow Strut Joiner

- Includes: 2 Cam screws
- Material: 12 gauge (2.6)
- Standard finish: ZN

Note: B767-22 (Cast Aluminum Fitting) does not require miter cutting of channel as shown in drawing.

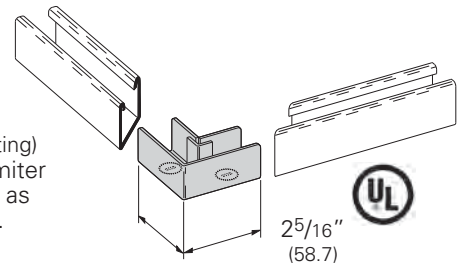

Part No.	For Channel Size	Wt./C	
		Lbs.	kg
B767-11	B11	74	(33.5)
B767-12	B12	56	(25.4)
B767-22 *	B22 & B24	39	(17.7)
B767-26	B26	41	(18.6)
B767-32	B32	34	(15.4)
B767-42	B42	27	(12.2)
B767-52	B52 & B54	23	(10.4)
B767-56	B56	25	(11.3)

* Cast aluminum parts

B768 Series Tee Strut Joiner

- Includes: 3 Cam screws
- Patented
- Material: 12 gauge (2.6)
- Standard finish: ZN

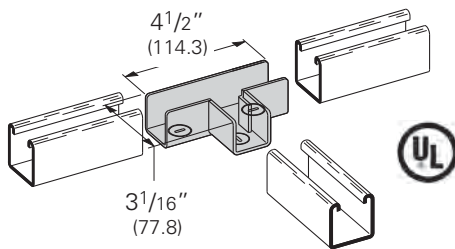

Part No.	For Channel Size	Wt./C	
		Lbs.	kg
B768-11	B11	142	(64.4)
B768-12	B12	112	(50.8)
B768-22 *	B22 & B24	79	(35.8)
B768-26	B26	79	(35.8)
B768-32	B32	72	(32.6)
B768-42	B42	62	(28.1)
B768-52	B52 & B54	57	(25.8)
B768-56	B56	60	(27.2)

* Cast aluminum parts

B769 Series Cross Strut Joiner

- Includes: 4 Cam screws
- Patented
- Material: 12 gauge (2.6)
- Standard finish: ZN

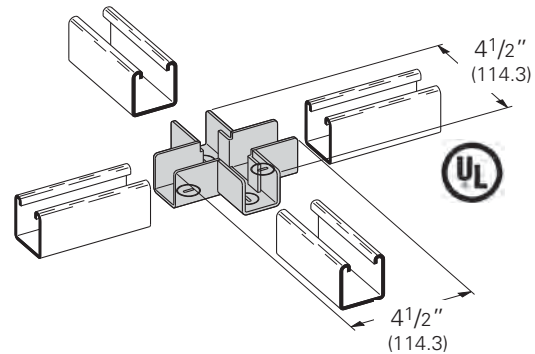

Part No.	For Channel Size	Wt./C	
		Lbs.	kg
B769-11	B11	148	(67.1)
B769-12	B12	120	(54.4)
B769-22 *	B22 & B24	87	(39.4)
B769-26	B26	93	(42.2)
B769-32	B32	78	(35.4)
B769-42	B42	65	(29.5)
B769-52	B52 & B54	58	(26.3)
B769-56	B56	62	(28.1)

* Cast aluminum parts

Note: Strut joiners are not for structural support. A channel support is recommended within 24" (609 mm) of each joint.

Reference page 206 for general fitting and standard finish specifications. U.L. Wire Fill Chart on pages 272 - 273.

Strut Joiners & Electrical Hardware

B166 Four Hole Splice Clevis

- Includes:
 - 1 Splice clevis
 - 4 pcs. 1/4"-20 Flat head machine screws
 - 4 pcs. N224WO channel nuts
- Material: 16 gauge (1.5)
- Standard finishes: ZN, GRN

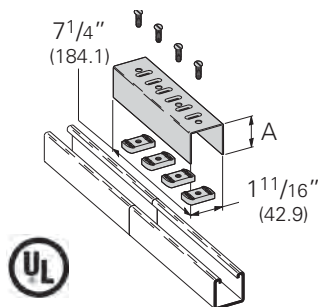

Part No.	A		For Channel Size	Wt./C	
	In.	mm		Lbs.	kg
B166-11	3 1/4"	(82.5)	B11	128	(58.0)
B166-12	2 7/16"	(61.9)	B12	108	(49.0)
B166-22	1 5/8"	(41.3)	B22, B24, B26	91	(40.3)
B166-32	1 3/8"	(34.9)	B32	83	(37.6)
B166-42	1"	(25.4)	B42	75	(34.0)
B166-52	1 3/16"	(20.6)	B52, B54, B56	71	(32.2)

B166-46 Four Hole Splice Clevis Assembly

- Requires ground wire for use with UL listed channel raceway system
- Includes:
 - 1 Splice clevis
 - 1 pc. B466W tapped plate
 - 4 pcs. 1/4"-20 Flat Head Machine Screws
- Material: 16 gauge (1.5)
- Standard finishes: ZN, GRN

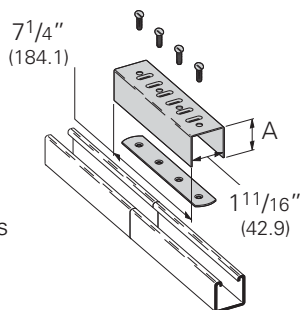

Part No.	A		For Channel Size	Wt./C	
	In.	mm		Lbs.	kg
B166-46-11	3 1/4"	(82.5)	B11	118	(53.5)
B166-46-12	2 7/16"	(61.9)	B12	98	(44.4)
B166-46-22	1 5/8"	(41.3)	B22, B24, B26	79	(35.8)
B166-46-32	1 3/8"	(34.9)	B32	73	(33.1)
B166-46-42	1"	(25.4)	B42	65	(29.5)
B166-46-52	1 3/16"	(20.6)	B52, B54, B56	61	(27.6)

B393-1 Wiring Stud

- Requires ground wire for use with UL listed channel raceway system
- 1/2" (15) pipe threads
- Material: Cast aluminum
- Wt./C 6 Lbs. (2.7 kg)

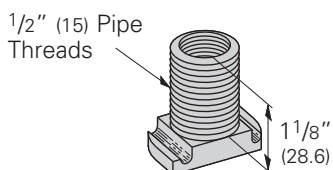

B589 Spacer Clevis

- Can be used with B393-1 wiring stud
- Material: 12 gauge (2.6)
- Standard finish: ZN
- Wt./C 29 Lbs. (13.1 kg)

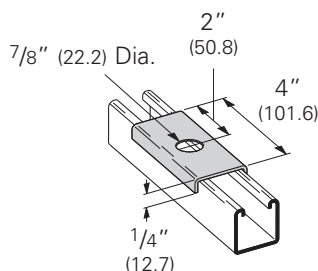

B619 Knock-Out Plate

- Requires ground wire for use with UL listed channel raceway system
- Includes: 2 pcs. 1/4"-20 Flat head machine screws
2 pcs. N224WO Channel nuts
- Material: 16 gauge (1.5) - 1/2" (15) conduit knockouts
- Standard finish: ZN
- Wt./C 40 Lbs. (18.1 kg)

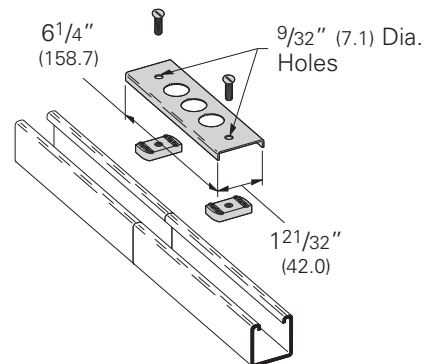

B166CL Splice Clevis Clip

- Use to cover gap between strut
- Material: 18 gauge (1.2)
- Standard finish: ZN
- Wt./C 4 Lbs. (1.8 kg)

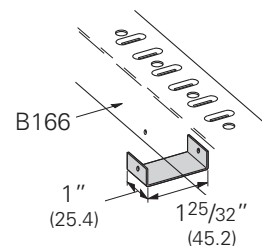

B590 Fiber Wire Retainer

- Installation aid for retaining wires before installing snap closure strip
- Wt./C 1 Lb. (.4 kg)

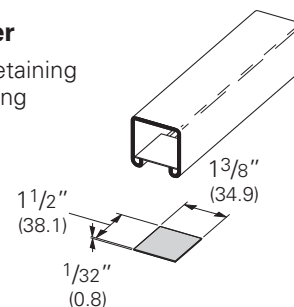

B617 Shoulder Bolt

- Standard finish: ZN
- Wt./C 6 Lbs. (2.7 kg)

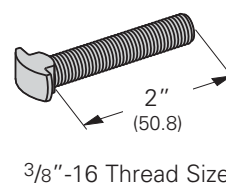

Reference page 206 for general fitting and standard finish specifications. U.L. Wire Fill Chart on pages 272 - 273.

Electrical Hardware & Porcelain Saddles

B446A Swivel Hanger (Female Only)

- Design Load:
(3/8)-610 Lbs. (2.71 kN)
(1/2)-1130 Lbs. (5.02 kN)
- Safety Factor of 3
- Standard finish: ZN

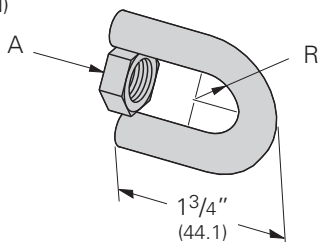

Part No.	A		R		Wt./C	
	In.	mm	In.	mm	Lbs.	kg
B446A-3/8	3/8"	-16 HN	9/32"	(7.1)	13	(5.9)
B446A-1/2	1/2"	-13 HN	3/8"	(9.5)	15	(6.8)

B446B Swivel Hanger (Male Only)

- Design Load:
(3/8)-610 Lbs. (2.71 kN)
(1/2)-1130 Lbs. (5.02 kN)
- Safety Factor of 3
- Standard finish: ZN

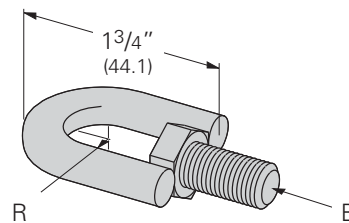

Part No.	A		R		Wt./C	
	In.	mm	In.	mm	Lbs.	kg
B446B-3/8	3/8"	-16 HHCS	9/32"	(7.1)	16	(7.2)
B446B-1/2	1/2"	-13 HHCS	3/8"	(9.5)	20	(9.1)

B446C Swivel Hanger (Female-Female)

- Design Load:
(3/8)-610 Lbs. (2.71 kN)
(1/2)-1130 Lbs. (5.02 kN)
- Safety Factor of 3
- Standard finish: ZN

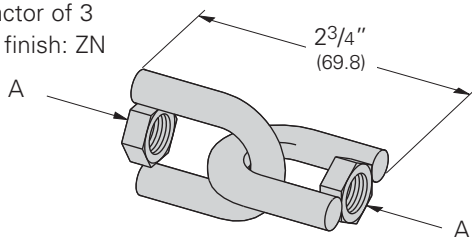

Part No.	A		Wt./C	
	In.	mm	Lbs.	kg
B446C-3/8	3/8"	-16 HN	26	(11.8)
B446C-1/2	1/2"	-13 HN	31	(14.0)

B446 Swivel Hanger (Female-Male)

- Design Load:
(3/8)-610 Lbs. (2.71 kN)
(1/2)-1130 Lbs. (5.02 kN)
- Safety Factor of 3
- Standard finish: ZN

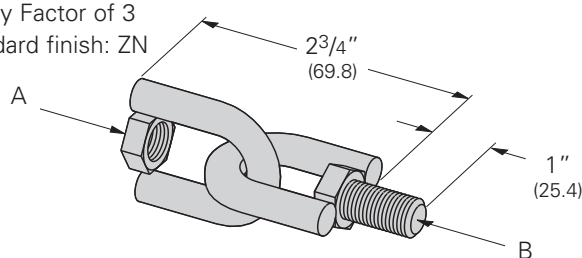

Part No.	A		B		Wt./C	
	In.	mm	In.	mm	Lbs.	kg
B446-3/8	3/8"	-16 HN	3/8"	-16 HHCS	28	(12.7)
B446-1/2	1/2"	-13 HN	1/2"	-13 HHCS	36	(16.3)

B4050 & B4051 Porcelain Cable Channel Saddle

- Electrical porcelain has an dielectric strength of 50 volts/mil

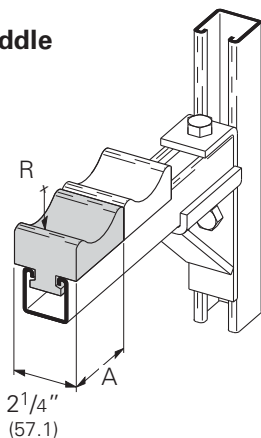

Part No.	A		R		Wt./C	
	In.	mm	In.	mm	Lbs.	kg
B4050	3"	(76.2)	1 3/8"	(34.9)	72	(32.6)
B4051	4"	(101.6)	2 1/8"	(54.0)	100	(45.3)

B4094 & B4095 Porcelain Cable Rack Saddle

- Electrical porcelain has an dielectric strength of 50 volts/mil
- Designed for use with B449 brackets

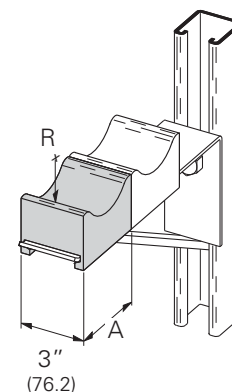

Part No.	A		R		Wt./C	
	In.	mm	In.	mm	Lbs.	kg
B4094	2 7/8"	(73.0)	1 3/8"	(34.9)	67	(30.4)
B4095	3 7/8"	(98.4)	2 1/8"	(54.0)	106	(48.1)

Reference page 206 for general fitting and standard finish specifications. U.L. Wire Fill Chart on pages 272 - 273.

Insulclamp Clamps

B4060 THRU B4093 Insulclamp™ Cable Clamps (Replaces porcelain clamps)

- Assembly includes:
1 Insulclamp & 1 pr. zinc plated pipe straps with Everdur (Silicon Bronze) hardware
- The thermoplastic elastomer Insulclamp has a dielectric strength of 640 volts/mil
- The flame retardant one piece design allows for trouble free assembly
- Everdur hardware is non-ferrous and prevents magnetic induction



OSO

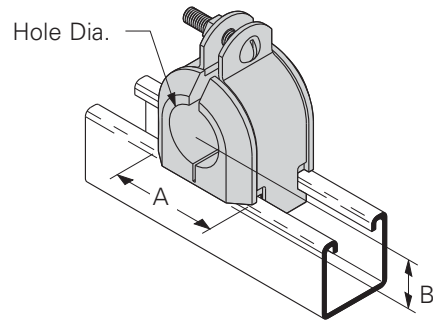

Part No.	Hole Dia.		Wt./C		A		B		Includes Clamp No.
	In.	mm	Lbs.	kg	In.	mm	In.	mm	
B4060	3/8"	(9.5)	25	(11.3)					
B4061	1/2"	(12.7)	25	(11.3)	1.36"	(34.5)	.56"	(14.2)	B2030
B4062	5/8"	(15.9)	25	(11.3)					
B4063	3/4"	(19.0)	37	(16.8)					
B4064	7/8"	(22.2)	37	(16.8)	1.86"	(47.2)	.81"	(20.8)	B2011
B4065	1"	(25.4)	37	(16.8)					
B4066	1 1/8"	(28.6)	37	(16.8)					
B4067	1 1/4"	(31.7)	58	(26.3)					
B4068	1 3/8"	(34.9)	58	(26.3)	2.36"	(59.9)	1.06"	(26.9)	B2038
B4069	1 1/2"	(38.1)	58	(26.3)					
B4070	1 5/8"	(41.3)	58	(26.3)					
B4071	1 3/4"	(44.4)	76	(34.5)					
B4072	1 7/8"	(47.6)	76	(34.5)	2.86"	(72.6)	1.31"	(33.3)	B2042
B4073	2"	(50.8)	76	(34.5)					
B4074	2 1/8"	(54.0)	76	(34.5)					
B4075	2 1/4"	(57.1)	90	(40.8)					
B4076	2 3/8"	(60.3)	90	(40.8)	3.36"	(85.3)	1.56"	(39.6)	B2046
B4077	2 1/2"	(63.5)	90	(40.8)					
B4078	2 5/8"	(66.7)	90	(40.8)					
B4079	2 3/4"	(69.8)	109	(49.4)					
B4080	2 7/8"	(73.0)	109	(49.4)	3.86"	(98.0)	1.81"	(46.0)	B2050
B4081	3"	(76.2)	109	(49.4)					
B4082	3 1/8"	(79.4)	109	(49.4)					
B4083	3 1/4"	(82.5)	130	(58.9)					
B4084	3 3/8"	(85.7)	130	(58.9)	4.36"	(110.7)	2.06"	(52.3)	B2054
B4085	3 1/2"	(88.9)	130	(58.9)					
B4086	3 5/8"	(92.1)	130	(58.9)					
B4087	3 3/4"	(95.2)	160	(72.6)					
B4088	3 7/8"	(98.4)	160	(72.6)	4.86"	(123.4)	2.31"	(58.7)	B2058
B4089	4"	(101.6)	160	(72.6)					
B4090	4 1/8"	(104.8)	160	(72.6)					
B4091	4 1/4"	(107.9)	160	(72.6)					
B4092	4 3/8"	(111.1)	160	(72.6)	5.24"	(133.1)	2.50"	(63.5)	B2018
B4093	4 1/2"	(114.3)	160	(72.6)					

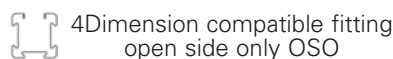

4Dimension compatible fitting
open side only OSO

Reference page 206 for general fitting and standard finish specifications. U.L. Wire Fill Chart on pages 272 - 273.