

Pipe/Conduit Clamps & Hangers



Our beam attachments and pipe supports offered in this section are designed to provide supports without drilling or welding. A complete selection of beam clamps, pipe clamps, rollers, supports and accessories are designed for use with our channels and offer many installation advantages.

Materials & Finishes*

Pipe clamps, pipe hangers, beam clamps, brackets, and rollers are made from low carbon steel strips, plates or rod unless noted.

*Unless otherwise noted.

Load Data

The load data published includes a safety factor of 5.0 unless noted (safety factor = ratio of ultimate load to the design load).

Recommended Bolt Torque (unless noted)

*See chart on page 154 for recommended setscrew torquing.

Finish Code	Finish	Specification
PLN	Plain	ASTM A1011 33,000 PSI min. yield
ZN	Electro-Plated Zinc	ASTM B633 SC3 Type III or ASTM A653
GRN	DURA GREEN™	
DCU	DURA-COPPER™	
HDG	Hot-Dipped Galvanized	ASTM A123
YZN	Yellow Zinc Chromate	ASTM B633 SC3 Type II
SS4	Stainless Steel Type 304	ASTM A240
SS6	Stainless Steel Type 316	ASTM A240
AL	Aluminum	ASTM B209

Bolt Size	1/4"-20	5/16"-18	3/8"-16	1/2"-13
Foot/Lbs.	6	11	19	50
Nm	8	15	26	68

Metric

Metric dimensions are shown in parentheses. Unless noted, all metric dimensions are in millimeters.

B2207 thru B2213 Multi-Grip Pipe Clamps for Thinwall (EMT), I.M.C., Rigid Conduit or Pipe

- Safety Factor of 5
- Add PA to suffix for pre-assembled pipe clamps
- Includes combination recess hex head machine screw and square nut
- Material: ASTM A1011 33,000 PSI min. yield
- Standard finish: ZN



For UL installations, follow Table 9 in UL2239.

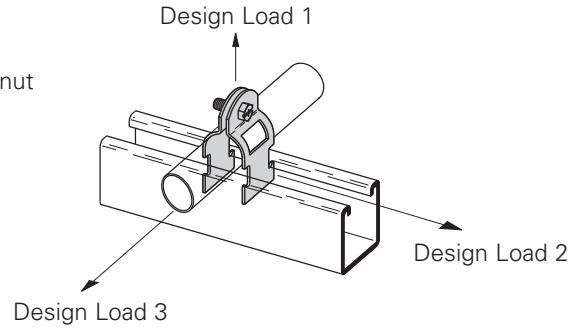

Part No.	Nominal Size In. mm	Material Thickness In. mm	O.D. Size Range		Alternate For Clamp No.'s	Design Load 1		Design Load 2		Design Load 3		Wt./C	
			In.	mm		Lbs.	kN	Lbs.	kN	Lbs.	kN	Lbs.	kg
B2207	3/8" (10)	16 Ga. (1.5)	.557-.706	(14.2-17.9)	B2000, B2001, B2026	400	(1.78)	50	(.22)	50	(.22)	9	(4.1)
B2208	1/2" (15)	16 Ga. (1.5)	.701-.875	(17.8-22.2)	B2001, B2008, B2027, B2028	400	(1.78)	50	(.22)	50	(.22)	11	(5.0)
B2209	3/4" (20)	14 Ga. (1.9)	.917-1.081	(23.2-27.4)	B2002, B2009,	400	(1.78)	50	(.22)	50	(.22)	12	(5.4)
B2210	1" (25)	14 Ga. (1.9)	1.125-1.375	(28.6-34.9)	B2003, B2010, B2030, B2031,	400	(1.78)	50	(.22)	50	(.22)	13	(5.9)
B2211	1 1/4" (32)	14 Ga. (1.9)	1.500-1.691	(38.1-42.9)	B2004, B2011, B2033, B2034	400	(1.78)	50	(.22)	50	(.22)	15	(6.8)
B2212	1 1/2" (40)	12 Ga. (2.6)	1.735-1.931	(44.0-49.0)	B2005, B2012, B2035	600	(2.67)	75	(.33)	75	(.33)	23	(10.4)
B2213	2" (50)	12 Ga. (2.6)	2.192-2.400	(55.7-60.9)	B2006, B2013 B2039	600	(2.67)	75	(.33)	75	(.33)	26	(11.8)

Pipe/Conduit Clamps & Hangers

BPC-8 thru BPC-64 Break-Apart Conduit Clamp

- Design Load 200 Lbs. (.896 kN)
- Includes combination recess hex head machine screw
- Material: ASTM A1011 33,000 PSI min. yield
- Standard finish: ZN



For UL installations, follow Table 9 in UL2239.

Part No.	Rigid or EMT Conduit Size		Wt./C	
	In.	mm	Lbs.	kg
BPC-8	1/2"	(21.3)	11.2	(5.1)
BPC-12	3/4"	(26.7)	12.7	(5.8)
BPC-16	1"	(33.4)	14.5	(6.6)
BPC-20	1 1/4"	(42.2)	16.5	(7.5)
BPC-24	1 1/2"	(48.3)	18.5	(8.4)
BPC-32	2"	(60.3)	21.5	(9.8)
BPC-40	2 1/2"	(73.0)	21.5	(9.8)
BPC-48	3"	(88.9)	22.0	(10.0)
BPC-56	3 1/2"	(101.6)	23.0	(10.4)
BPC-64	4"	(114.3)	27.5	(12.5)

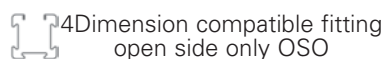
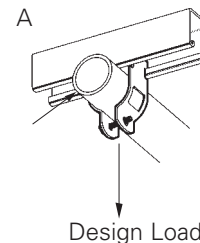

Reference page 168 for general fitting and standard finish specifications.

Pipe Clamps

BCTS Series Conduit Trapeze Support For Thinwall (EMT), Rigid Conduit or Pipe

- Used to support multiple runs of conduit/pipe on same elevation
- Available in three sizes:
 - BCTS1** series for up to 1 1/4" EMT or 1" Rigid conduit - 16 ga. (1.5mm)
 - BCTS2** series for up to 2" EMT or 2" Rigid conduit - 16 ga. (1.5mm)
 - BCTS3** series for up to 4" EMT or 4" Rigid conduit - 14 ga. (1.9mm)
- Multiple lengths available in 6" (152mm) intervals from 12" (305mm) to 120" (3048mm)
- Can be supported with 3/8" or 1/2" threaded rod or bolts by simply flipping the part from top to bottom (threaded rod and hardware is not included)
- Reduces need for conduit/pipe clamps at every support location
- Can be tiered to support multiple conduit/pipe levels
- Can also support Flextray™ and cable tray
- Flange hole patterns provide multiple options for hanger rods, mounting hardware, or accessories
- Repeating 6" (152mm) hole pattern for field cutting
- Hanger rod spacing should not exceed 36" (914mm)
- UL Listed for US and Canada - 500 lb. (22.2kN) load rating at 12" (305mm) hanger spacing for all three sizes - safety factor of 3
- Material: Pre-Galvanized Steel, Stainless Steel Type 316 (add SS6 to part number, i.e. BCTS1-24SS6)

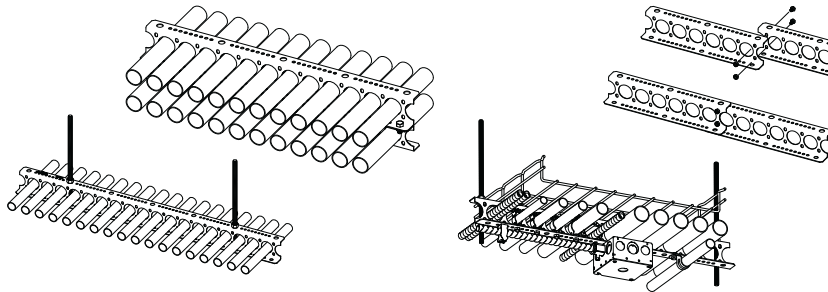
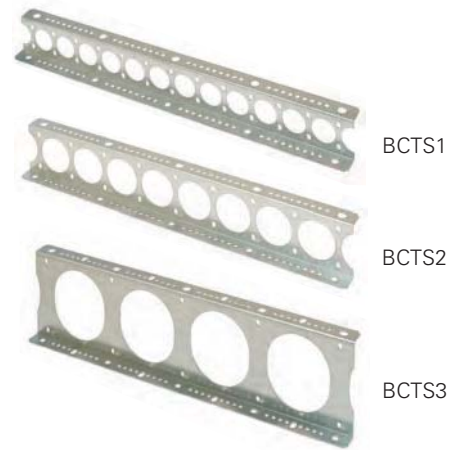

BCTS1 Series - 1 1/4" EMT/1" Rigid Maximum

Hanger rod spacing loads: Safety Factor of 3 - Evenly distributed maximum loads • 24" (609mm) is 450 lbs. (2.00kN) • 36" (914mm) is 350 lbs. (1.55kN)

Part No.	Nominal Length		Overall Length		Conduit Holes	Wt./Each	
	In.	mm	In.	mm		Lbs.	kg
BCTS1-12	12	(305)	14	(355)	6	0.87	(0.39)
BCTS1-18	18	(457)	20	(508)	9	1.24	(0.56)
BCTS1-24	24	(609)	26	(660)	12	1.62	(0.73)
BCTS1-30	30	(762)	32	(813)	15	1.99	(0.90)
BCTS1-36	36	(914)	38	(965)	18	2.37	(1.07)
BCTS1-42	42	(1067)	44	(1117)	21	2.74	(1.24)
BCTS1-48	48	(1219)	50	(1270)	24	3.11	(1.41)
BCTS1-54	54	(1371)	56	(1422)	27	3.49	(1.58)
BCTS1-60	60	(1524)	62	(1575)	30	3.86	(1.75)
BCTS1-66	66	(1676)	68	(1727)	33	4.23	(1.92)
BCTS1-72	72	(1829)	74	(1879)	36	4.61	(2.09)
BCTS1-78	78	(1981)	80	(2032)	39	4.98	(2.26)
BCTS1-84	84	(2133)	86	(2184)	42	5.36	(2.43)
BCTS1-90	90	(2286)	92	(2337)	45	5.73	(2.60)
BCTS1-96	96	(2438)	98	(2489)	48	6.10	(2.76)
BCTS1-102	102	(2591)	104	(2641)	51	6.48	(2.94)
BCTS1-108	108	(2743)	110	(2794)	54	6.85	(3.11)
BCTS1-114	114	(2895)	116	(2946)	57	7.22	(3.27)
BCTS1-120	120	(3048)	122	(3099)	60	7.60	(3.45)

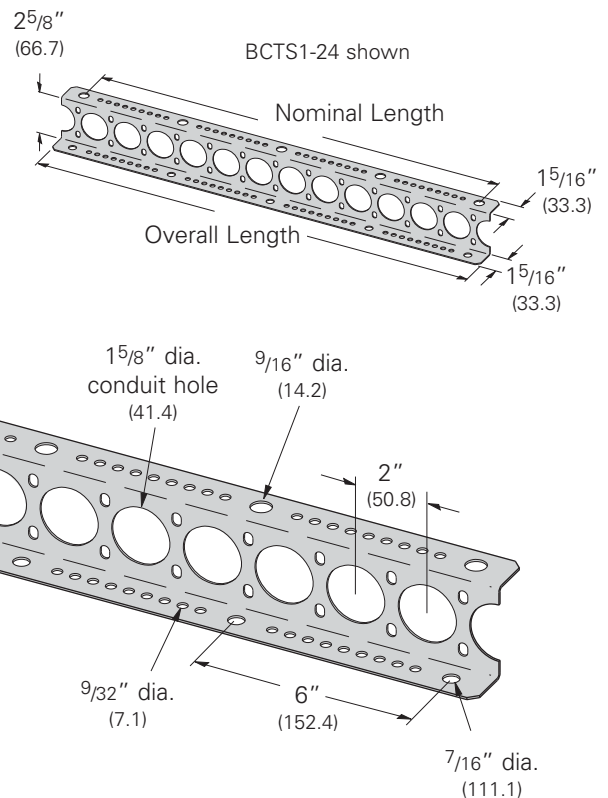

Reference page 168 for general fitting and standard finish specifications.

BCTS Series Conduit Trapeze Support For Thinwall (EMT), Rigid Conduit or Pipe (Continued)

BCTS2 Series - 2" EMT/2" Rigid Maximum

Hanger rod spacing loads: Safety Factor of 3 - Evenly distributed maximum loads • 24" (609mm) is 400 lbs. (1.78kN) • 36" (914mm) is 300 lbs. (1.33kN)

Part No.	Nominal Length		Overall Length		Conduit Holes	Wt./Each	
	In.	mm	In.	mm		Lbs.	kg
BCTS2-12	12	(305)	14	(355)	4	0.95	(0.43)
BCTS2-18	18	(457)	20	(508)	6	1.35	(0.61)
BCTS2-24	24	(609)	26	(660)	8	1.75	(0.79)
BCTS2-30	30	(762)	32	(813)	10	2.15	(0.97)
BCTS2-36	36	(914)	38	(965)	12	2.55	(1.15)
BCTS2-42	42	(1067)	44	(1117)	14	2.95	(1.34)
BCTS2-48	48	(1219)	50	(1270)	16	3.35	(1.52)
BCTS2-54	54	(1371)	56	(1422)	18	3.75	(1.70)
BCTS2-60	60	(1524)	62	(1575)	20	4.15	(1.88)
BCTS2-66	66	(1676)	68	(1727)	22	4.55	(2.06)
BCTS2-72	72	(1829)	74	(1879)	24	4.95	(2.24)
BCTS2-78	78	(1981)	80	(2032)	26	5.35	(2.42)
BCTS2-84	84	(2133)	86	(2184)	28	5.75	(2.61)
BCTS2-90	90	(2286)	92	(2337)	30	6.15	(2.79)
BCTS2-96	96	(2438)	98	(2489)	32	6.55	(2.97)
BCTS2-102	102	(2591)	104	(2641)	34	6.95	(3.15)
BCTS2-108	108	(2743)	110	(2794)	36	7.35	(3.33)
BCTS2-114	114	(2895)	116	(2946)	38	7.75	(3.51)
BCTS2-120	120	(3048)	122	(3099)	40	8.15	(3.69)

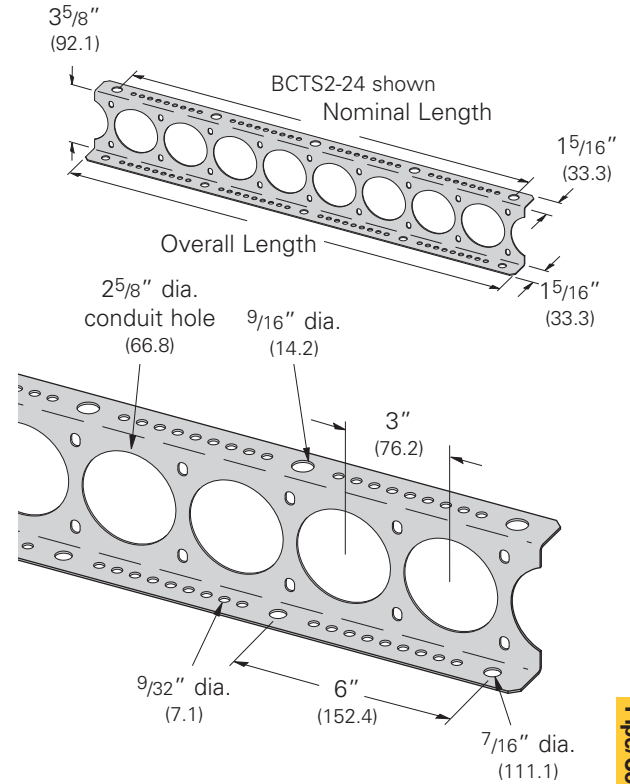

BCTS3 Series - 4" EMT/4" Rigid Maximum

Hanger rod spacing loads: Safety Factor of 3 - Evenly distributed maximum loads • 24" (609mm) is 800 lbs. (3.56kN) • 36" (914mm) is 750 lbs. (3.33kN)

Part No.	Nominal Length		Overall Length		Conduit Holes	Wt./Each	
	In.	mm	In.	mm		Lbs.	kg
BCTS3-12	12	(305)	14	(355)	2	1.68	(0.76)
BCTS3-18	18	(457)	20	(508)	3	2.35	(1.06)
BCTS3-24	24	(609)	26	(660)	4	3.02	(1.37)
BCTS3-30	30	(762)	32	(813)	5	3.69	(1.67)
BCTS3-36	36	(914)	38	(965)	6	4.36	(1.98)
BCTS3-42	42	(1067)	44	(1117)	7	5.04	(2.28)
BCTS3-48	48	(1219)	50	(1270)	8	5.71	(2.59)
BCTS3-54	54	(1371)	56	(1422)	9	6.38	(2.89)
BCTS3-60	60	(1524)	62	(1575)	10	7.05	(3.20)
BCTS3-66	66	(1676)	68	(1727)	11	7.72	(3.50)
BCTS3-72	72	(1829)	74	(1879)	12	8.40	(3.81)
BCTS3-78	78	(1981)	80	(2032)	13	9.07	(4.11)
BCTS3-84	84	(2133)	86	(2184)	14	9.74	(4.42)
BCTS3-90	90	(2286)	92	(2337)	15	10.41	(4.72)
BCTS3-96	96	(2438)	98	(2489)	16	11.08	(5.02)
BCTS3-102	102	(2591)	104	(2641)	17	11.75	(5.33)
BCTS3-108	108	(2743)	110	(2794)	18	12.43	(5.64)
BCTS3-114	114	(2895)	116	(2946)	19	13.10	(5.94)
BCTS3-120	120	(3048)	122	(3099)	20	13.77	(6.24)

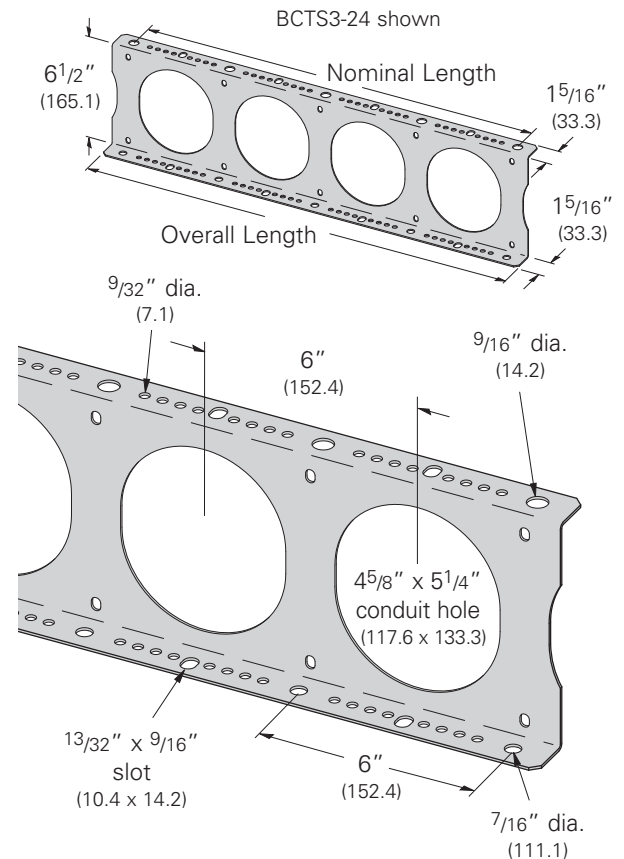

Reference page 168 for general fitting and standard finish specifications.

Pipe Clamps

B2000 Series Pipe and Conduit Clamps

- Safety Factor of 5
- Add PA to suffix for pre-assembled pipe clamps
- Includes combination recess hex head machine screw and square nut
- Material: 16 Ga. (1.5), 14 Ga. (1.9), 12 Ga. (2.6) ASTM A653 33,000 PSI min. yield and 11 Ga. (3.0) ASTM A1011HSLA Gr. 50
- Standard finishes: ZN, HDG, SS4, SS6, AL

Note: For EMT sizes 2 1/2" and larger use rigid conduit sizes.

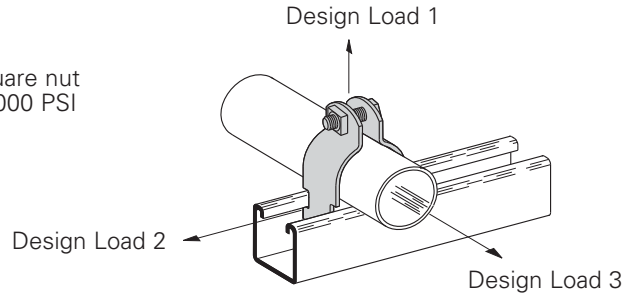

Thinwall Conduit (EMT) Clamps

Part No.	Conduit Size		Material Thickness		Design Load 1		Design Load 2		Design Load 3		Wt./C	
	In.	mm	In.	mm	Lbs.	kN	Lbs.	kN	Lbs.	kN	Lbs.	kg
B2000	3/8"	(10)	16 Ga.	(1.5)	400 U	(1.78)	50	(.22)	50	(.22)	10	(4.5)
B2001	1/2"	(15)	16 Ga.	(1.5)	400 U	(1.78)	50	(.22)	50	(.22)	10	(4.5)
B2002	3/4"	(20)	16 Ga.	(1.9)	400 U	(1.78)	50	(.22)	50	(.22)	11	(5.0)
B2003	1"	(25)	14 Ga.	(1.9)	600 U	(2.67)	75	(.33)	75	(.33)	16	(7.2)
B2004	1 1/4"	(32)	14 Ga.	(1.9)	600 U	(2.67)	75	(.33)	75	(.33)	19	(8.6)
B2005	1 1/2"	(40)	12 Ga.	(2.6)	800 U	(3.56)	125	(.56)	125	(.56)	28	(12.7)
B2006	2"	(50)	12 Ga.	(2.6)	800 U	(3.56)	125	(.56)	125	(.56)	33	(14.9)

Rigid or Conduit or Pipe Clamps

Part No.	Conduit Size		Material Thickness		Design Load 1		Design Load 2		Design Load 3		Wt./C	
	In.	mm	In.	mm	Lbs.	kN	Lbs.	kN	Lbs.	kN	Lbs.	kg
B2001	3/8"	(10)	16 Ga.	(1.5)	400 U	(1.78)	50	(.22)	50	(.22)	10	(4.5)
B2008	1/2"	(15)	16 Ga.	(1.5)	400 U	(1.78)	50	(.22)	50	(.22)	11	(5.0)
B2009	3/4"	(20)	14 Ga.	(1.9)	600 U	(2.67)	75	(.33)	75	(.33)	15	(6.8)
B2010	1"	(25)	14 Ga.	(1.9)	600 U	(2.67)	75	(.33)	75	(.33)	16	(7.2)
B2011	1 1/4"	(32)	14 Ga.	(1.9)	600 U	(2.67)	75	(.33)	75	(.33)	20	(9.1)
B2012	1 1/2"	(40)	12 Ga.	(2.6)	800 U	(3.56)	125	(.56)	125	(.56)	30	(13.6)
B2013	2"	(50)	12 Ga.	(2.6)	800 U	(3.56)	125	(.56)	125	(.56)	34	(15.4)
B2014	2 1/2"	(65)	12 Ga.	(2.6)	800 U	(3.56)	125	(.56)	125	(.56)	38	(17.2)
B2015	3"	(80)	12 Ga.	(2.6)	800 U	(3.56)	125	(.56)	125	(.56)	44	(19.9)
B2016	3 1/2"	(90)	11 Ga.	(3.0)	1000 U	(4.45)	200	(.89)	150	(.67)	61	(27.6)
B2017	4"	(100)	11 Ga.	(3.0)	1000 U	(4.45)	200	(.89)	150	(.67)	66	(29.9)
B2018	4 1/2"	(115)	11 Ga.	(3.0)	1000 U	(4.45)	200	(.89)	150	(.67)	70	(31.7)
B2019	5"	(125)	11 Ga.	(3.0)	1000 U	(4.45)	200	(.89)	150	(.67)	77	(34.9)
B2020	6"	(150)	11 Ga.	(3.0)	1000 U	(4.45)	200	(.89)	150	(.67)	100	(45.3)
B2021	7"	(175)	11 Ga.	(3.0)	1000	(4.45)	250	(1.11)	200	(.89)	115	(52.1)
B2022	8"	(200)	11 Ga.	(3.0)	1000	(4.45)	250	(1.11)	200	(.89)	128	(58.0)
B2130	10"	(254)	11 Ga.	(3.0)	1000	(4.45)	250	(1.11)	200	(.89)	160	(72.6)
B2132	12"	(305)	11 Ga.	(3.0)	1000	(4.45)	250	(1.11)	200	(.89)	185	(83.9)



As shown with **U** For UL installations, follow Table 9 in UL2239.



4Dimension compatible fitting
open side only OSO

Reference page 168 for general fitting and standard finish specifications.

B2000 Series PVC Clamps

- Safety Factor of 5
- Add PA to suffix for pre-assembled pipe clamps
- Includes combination recess hex head machine screw and square nut
- Material: 16 Ga. (1.5), 14 Ga. (1.9), 12 Ga. (2.6) ASTM A653 33,000 PSI min. yield and 11 Ga. (3.0) ASTM A1011HSLA Gr. 50
- Standard finishes: PVC



Design Load 2

Design Load 1

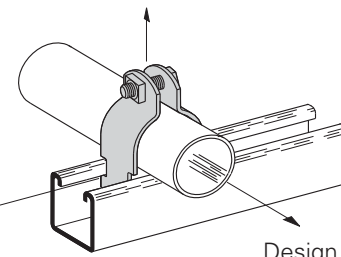

Design Load 3

Clamp Sizing Chart for PVC Coated Rigid Conduit and Clamps

Nominal Conduit Size	Conduit Coating			
	.020 (.51mm)		.040 (1.01mm)	
	Clamp Coating		Clamp Coating	
In. mm	0	.020" (.51mm)	0	.020" (.51mm)
1/2" (15)	B2008	B2002	B2002	B2009
3/4" (20)	B2030	B2030	B2030	B2003
1" (25)	B2032	B2010	B2010	B2004
1 1/4" (32)	B2005	B2005	B2005	B2005
1 1/2" (40)	B2012	B2037	B2037	B2037
2" (50)	B2013	B2041	B2041	B2041
2 1/2" (65)	B2014	B2045	B2045	B2045
3" (80)	B2015	B2050	B2050	B2050
3 1/2" (90)	B2016	B2054	B2054	B2054
4" (100)	B2017	B2058	B2058	B2058
5" (125)	B2019	B2066	B2066	B2066
6" (150)	B2020	B2115	B2115	B2115

*See B2000 O.D. pipe and conduit clamp chart on pgs. 131-132 for corresponding clamp load data.

Clamp Sizing Chart for PVC Coated Thinwall (EMT) Conduit and Clamps

Nominal Conduit Size	Conduit Coating			
	.020 (.51mm)		.040 (1.01mm)	
	Clamp Coating		Clamp Coating	
In. mm	0	.020" (.51mm)	0	.020" (.51mm)
3/8" (10)	B2026	B2026	B2026	B2001
1/2" (15)	B2027	B2027	B2027	B2008
3/4" (20)	B2009	B2009	B2009	B2009
1" (25)	B2003	B2031	B2031	B2031
1 1/4" (32)	B2004	B2011	B2011	B2011
1 1/2" (40)	B2005	B2005	B2005	B2012
2" (50)	B2039	B2039	B2039	B2013

*See B2000 O.D. pipe and conduit clamp chart on pgs. 131-132 for corresponding clamp load data.

B2000 Series Copper Tubing Clamps

- Safety Factor of 5
- Add PA to suffix for pre-assembled pipe clamps
- Includes combination recess hex head machine screw and square nut
- Material: 16 Ga. (1.5), 14 Ga. (1.9), 12 Ga. (2.6) ASTM A1011 33,000 PSI min. yield and 11 Ga. (3.0) ASTM A1011HSLA Gr. 50
- Standard finish: Exclusive DURA-COPPER™ Finish (DCU)



Design Load 2

Design Load 1

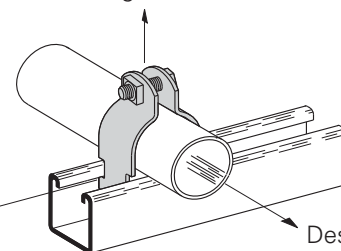

Design Load 3

Copper Tubing Clamps

Part No.	Tubing Size	O.D. Size		Material Thickness	Design Load 1		Design Load 2		Design Load 3		Wt./C	
		In.	(mm)		Lbs.	kN	Lbs.	kN	Lbs.	kN		
B2024DCU	1/4" (6.3)	.375	(9.5)	16 Ga. (1.5)	400	(1.78)	50	(.22)	50	(.22)	8	(3.6)
B2025DCU	3/8" (9.5)	.500	(12.7)	16 Ga. (1.5)	400	(1.78)	50	(.22)	50	(.22)	9	(4.1)
B2026DCU	1/2" (12.7)	.625	(15.9)	16 Ga. (1.5)	400	(1.78)	50	(.22)	50	(.22)	10	(4.5)
B2027DCU	5/8" (15.9)	.750	(19.0)	16 Ga. (1.5)	400	(1.78)	50	(.22)	50	(.22)	10	(4.5)
B2008DCU	3/4" (19.0)	.875	(22.2)	16 Ga. (1.5)	400	(1.78)	50	(.22)	50	(.22)	11	(5.0)
B2030DCU	1" (25.4)	1.125	(28.6)	14 Ga. (1.9)	600	(2.67)	75	(.33)	75	(.33)	15	(6.8)
B2010DCU	1 1/4" (31.7)	1.375	(34.9)	14 Ga. (1.9)	600	(2.67)	75	(.33)	75	(.33)	17	(7.7)
B2011DCU	1 1/2" (38.1)	1.625	(41.3)	14 Ga. (1.9)	600	(2.67)	75	(.33)	75	(.33)	19	(8.6)
B2038DCU	2" (50.8)	2.125	(54.0)	12 Ga. (2.6)	800	(3.56)	125	(.56)	125	(.56)	32	(14.5)
B2042DCU	2 1/2" (63.5)	2.625	(66.7)	12 Ga. (2.6)	800	(3.56)	125	(.56)	125	(.56)	35	(15.9)
B2046DCU	3" (76.2)	3.125	(79.4)	12 Ga. (2.6)	800	(3.56)	125	(.56)	125	(.56)	39	(17.7)
B2050DCU	3 1/2" (88.9)	3.625	(92.1)	11 Ga. (3.0)	1000	(4.45)	200	(.89)	150	(.67)	54	(24.5)
B2054DCU	4" (101.6)	4.125	(104.8)	11 Ga. (3.0)	1000	(4.45)	200	(.89)	150	(.67)	61	(27.6)
B2062DCU	5" (127.0)	5.125	(130.2)	11 Ga. (3.0)	1000	(4.45)	200	(.89)	150	(.67)	70	(31.7)
B2110DCU	6" (152.5)	6.125	(155.6)	11 Ga. (3.0)	1000	(4.45)	250	(1.11)	200	(.89)	94	(42.6)
B2126DCU	8" (203.2)	8.125	(206.4)	11 Ga. (3.0)	1000	(4.45)	250	(1.11)	200	(.89)	123	(55.8)

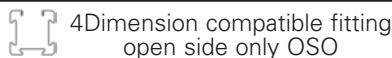

Reference page 168 for general fitting and standard finish specifications.

Pipe Clamps

B2000 Series O.D. Pipe and Conduit Clamps

- Safety Factor of 5
- Add PA to suffix for pre-assembled pipe clamps
- Other sizes available upon request
- Includes combination recess hex head machine screw and square nut.
- Material: 16 Ga. (1.5), 14 Ga. (1.9), 12 Ga. (2.6)
ASTM A653 33,000 PSI min. yield and 11 Ga. (3.0)
ASTM A1011HSLA Gr. 50
- Standard finishes: ZN, HDG, SS4

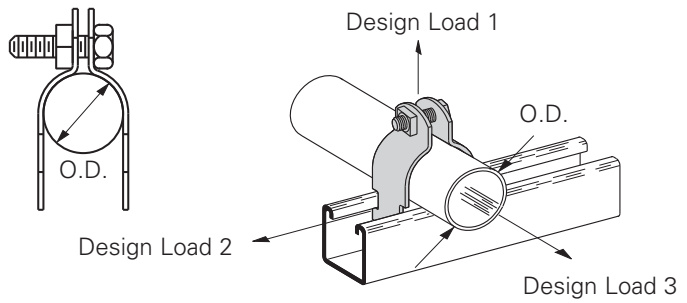

O.D. Clamps

Part No.	O.D. Size (in.)		Hardware Size	Material Gauge Thickness		Design Load 1		Design Load 2		Design Load 3		Wt./C	
	In.	mm		In.	mm	Lbs.	kN	Lbs.	kN	Lbs.	kN	Lbs.	kg
B2023	1/4"	(6.3)	1/4"-20	16	(1.5)	120	(.54)	30	(.13)	30	(.13)	8	(3.6)
B2024	3/8"	(9.5)	1/4"-20	16	(1.5)	300	(1.33)	40	(.18)	40	(.18)	8	(3.6)
B2025	1/2"	(12.7)	1/4"-20	16	(1.5)	400	(1.78)	50	(.22)	50	(.22)	9	(4.1)
B2026	5/8"	(15.9)	1/4"-20	16	(1.5)	400	(1.78)	50	(.22)	50	(.22)	10	(4.5)
B2027	3/4"	(19.0)	1/4"-20	16	(1.5)	400	(1.78)	50	(.22)	50	(.22)	10	(4.5)
B2008	7/8"	(22.2)	1/4"-20	16	(1.5)	400	(1.78)	50	(.22)	50	(.22)	11	(5.0)
B2009	1"	(25.4)	1/4"-20	14	(1.9)	500	(2.22)	75	(.33)	75	(.33)	15	(6.8)
B2030	1 1/8"	(28.6)	1/4"-20	14	(1.9)	600	(2.67)	75	(.33)	75	(.33)	15	(6.8)
B2031	1 1/4"	(31.7)	1/4"-20	14	(1.9)	600	(2.67)	75	(.33)	75	(.33)	16	(7.3)
B2010	1 3/8"	(34.9)	1/4"-20	14	(1.9)	600	(2.67)	75	(.33)	75	(.33)	17	(7.7)
B2004	1 1/2"	(38.1)	1/4"-20	14	(1.9)	600	(2.67)	75	(.33)	75	(.33)	18	(8.2)
B2011	1 5/8"	(41.3)	1/4"-20	14	(1.9)	600	(2.67)	75	(.33)	75	(.33)	19	(8.6)
B2005	1 3/4"	(44.4)	5/16"-18	12	(2.6)	800	(3.56)	125	(.56)	125	(.56)	29	(13.1)
B2012	1 7/8"	(47.6)	5/16"-18	12	(2.6)	800	(3.56)	125	(.56)	125	(.56)	30	(13.6)
B2037	2	(50.8)	5/16"-18	12	(2.6)	800	(3.56)	125	(.56)	125	(.56)	30	(13.6)
B2038	2 1/8"	(54.0)	5/16"-18	12	(2.6)	800	(3.56)	125	(.56)	125	(.56)	32	(14.5)
B2039	2 1/4"	(57.1)	5/16"-18	12	(2.6)	800	(3.56)	125	(.56)	125	(.56)	32	(14.5)
B2013	2 3/8"	(60.3)	5/16"-18	12	(2.6)	800	(3.56)	125	(.56)	125	(.56)	34	(15.4)
B2041	2 1/2"	(63.5)	5/16"-18	12	(2.6)	800	(3.56)	125	(.56)	125	(.56)	35	(15.9)
B2042	2 5/8"	(66.7)	5/16"-18	12	(2.6)	800	(3.56)	125	(.56)	125	(.56)	35	(15.9)
B2043	2 3/4"	(69.8)	5/16"-18	12	(2.6)	800	(3.56)	125	(.56)	125	(.56)	38	(17.2)
B2014	2 7/8"	(73.0)	5/16"-18	12	(2.6)	800	(3.56)	125	(.56)	125	(.56)	38	(17.2)
B2045	3	(76.2)	5/16"-18	12	(2.6)	800	(3.56)	125	(.56)	125	(.56)	38	(17.2)
B2046	3 1/8"	(79.4)	5/16"-18	12	(2.6)	800	(3.56)	125	(.56)	125	(.56)	39	(17.7)
B2047	3 1/4"	(82.5)	5/16"-18	12	(2.6)	800	(3.56)	125	(.56)	125	(.56)	41	(18.6)
B2048	3 3/8"	(85.7)	5/16"-18	12	(2.6)	800	(3.56)	125	(.56)	125	(.56)	43	(19.5)
B2015	3 1/2"	(88.9)	5/16"-18	12	(2.6)	800	(3.56)	125	(.56)	125	(.56)	44	(20.0)
B2050	3 5/8"	(92.1)	5/16"-18	11	(3.0)	1000	(4.45)	200	(.89)	150	(.67)	54	(24.5)
B2051	3 3/4"	(95.2)	5/16"-18	11	(3.0)	1000	(4.45)	200	(.89)	150	(.67)	57	(25.8)
B2052	3 7/8"	(98.4)	5/16"-18	11	(3.0)	1000	(4.45)	200	(.89)	150	(.67)	55	(25.0)
B2016	4	(101.6)	5/16"-18	11	(3.0)	1000	(4.45)	200	(.89)	150	(.67)	57	(25.8)
B2054	4 1/8"	(104.8)	5/16"-18	11	(3.0)	1000	(4.45)	200	(.89)	150	(.67)	61	(27.7)
B2055	4 1/4"	(107.9)	5/16"-18	11	(3.0)	1000	(4.45)	200	(.89)	150	(.67)	62	(28.1)
B2056	4 3/8"	(111.1)	5/16"-18	11	(3.0)	1000	(4.45)	200	(.89)	150	(.67)	64	(29.0)
B2017	4 1/2"	(114.3)	5/16"-18	11	(3.0)	1000	(4.45)	200	(.89)	150	(.67)	66	(29.9)
B2058	4 5/8"	(117.5)	5/16"-18	11	(3.0)	1000	(4.45)	200	(.89)	150	(.67)	66	(29.9)

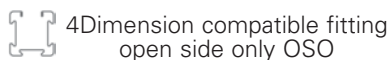

Reference page 168 for general fitting and standard finish specifications.

B2000 Series O.D. Pipe and Conduit Clamps

- Safety Factor of 5
- Add PA to suffix for pre-assembled pipe clamps
- Other sizes available upon request
- Includes combination recess hex head machine screw and square nut.
- Material: 16 Ga. (1.5), 14 Ga. (1.9), 12 Ga. (2.6)
ASTM A653 33,000 PSI min. yield and
11 Ga. (3.0) ASTM A1011HSLA Gr. 50
- Standard finishes: ZN, HDG, SS4

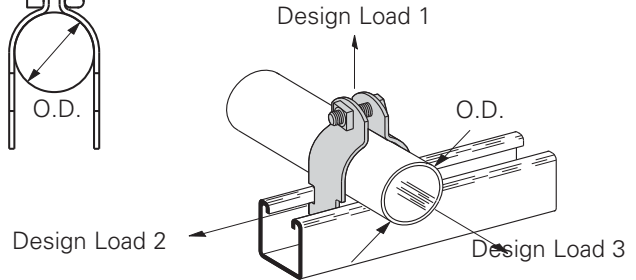
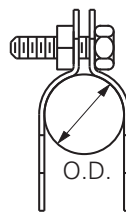

O.D. Clamps

Part No.	O.D. Size (in.)		Hardware Size	Material Gauge Thickness		Design Load 1		Design Load 2		Design Load 3		Wt./C	
	In.	mm		In.	mm	Lbs.	kN	Lbs.	kN	Lbs.	kN	Lbs.	kg
B2059	4 ³ / ₄ "	(120.6)	5/16"-18	11	(3.0)	1000	(4.45)	200	(.89)	150	(.67)	68	(30.8)
B2060	4 ⁷ / ₈ "	(123.8)	5/16"-18	11	(3.0)	1000	(4.45)	200	(.89)	150	(.67)	69	(31.3)
B2018	5	(127.0)	5/16"-18	11	(3.0)	1000	(4.45)	200	(.89)	150	(.67)	70	(31.8)
B2062	5 ¹ / ₈ "	(130.2)	5/16"-18	11	(3.0)	1000	(4.45)	200	(.89)	150	(.67)	70	(31.8)
B2063	5 ¹ / ₄ "	(133.3)	5/16"-18	11	(3.0)	1000	(4.45)	200	(.89)	150	(.67)	70	(31.8)
B2064	5 ³ / ₈ "	(136.5)	5/16"-18	11	(3.0)	1000	(4.45)	200	(.89)	150	(.67)	77	(34.9)
B2019	5 ¹ / ₂ "	(139.7)	5/16"-18	11	(3.0)	1000	(4.45)	200	(.89)	150	(.67)	78	(35.4)
B2066	5 ⁵ / ₈ "	(142.9)	3/8"-16	11	(3.0)	1000	(4.45)	200	(.89)	150	(.67)	83	(37.6)
B2067	5 ³ / ₄ "	(146.0)	3/8"-16	11	(3.0)	1000	(4.45)	200	(.89)	150	(.67)	84	(38.1)
B2068	5 ⁷ / ₈ "	(149.2)	3/8"-16	11	(3.0)	1000	(4.45)	200	(.89)	150	(.67)	85	(38.6)
B2069	6"	(152.4)	3/8"-16	11	(3.0)	1000	(4.45)	200	(.89)	150	(.67)	87	(39.5)
B2110	6 ¹ / ₈ "	(155.6)	3/8"-16	11	(3.0)	1000	(4.45)	250	(1.11)	200	(.89)	94	(42.6)
B2111	6 ¹ / ₄ "	(158.7)	3/8"-16	11	(3.0)	1000	(4.45)	250	(1.11)	200	(.89)	96	(43.5)
B2112	6 ³ / ₈ "	(161.9)	3/8"-16	11	(3.0)	1000	(4.45)	250	(1.11)	200	(.89)	98	(44.4)
B2113	6 ¹ / ₂ "	(165.1)	3/8"-16	11	(3.0)	1000	(4.45)	250	(1.11)	200	(.89)	99	(44.9)
B2020	6 ⁵ / ₈ "	(168.3)	3/8"-16	11	(3.0)	1000	(4.45)	250	(1.11)	200	(.89)	100	(45.4)
B2115	6 ³ / ₄ "	(171.4)	3/8"-16	11	(3.0)	1000	(4.45)	250	(1.11)	200	(.89)	102	(46.3)
B2116	6 ⁷ / ₈ "	(174.6)	3/8"-16	11	(3.0)	1000	(4.45)	250	(1.11)	200	(.89)	104	(47.2)
B2117	7"	(177.8)	3/8"-16	11	(3.0)	1000	(4.45)	250	(1.11)	200	(.89)	106	(48.1)
B2118	7 ¹ / ₈ "	(181.0)	3/8"-16	11	(3.0)	1000	(4.45)	250	(1.11)	200	(.89)	108	(49.0)
B2119	7 ¹ / ₄ "	(184.1)	3/8"-16	11	(3.0)	1000	(4.45)	250	(1.11)	200	(.89)	110	(49.9)
B2120	7 ³ / ₈ "	(187.3)	3/8"-16	11	(3.0)	1000	(4.45)	250	(1.11)	200	(.89)	112	(50.8)
B2121	7 ¹ / ₂ "	(190.5)	3/8"-16	11	(3.0)	1000	(4.45)	250	(1.11)	200	(.89)	114	(51.7)
B2021	7 ⁵ / ₈ "	(193.7)	3/8"-16	11	(3.0)	1000	(4.45)	250	(1.11)	200	(.89)	115	(52.2)
B2123	7 ³ / ₄ "	(196.8)	3/8"-16	11	(3.0)	1000	(4.45)	250	(1.11)	200	(.89)	117	(53.1)
B2124	7 ⁷ / ₈ "	(200.0)	3/8"-16	11	(3.0)	1000	(4.45)	250	(1.11)	200	(.89)	119	(54.0)
B2125	8"	(203.2)	3/8"-16	11	(3.0)	1000	(4.45)	250	(1.11)	200	(.89)	121	(54.9)
B2126	8 ¹ / ₈ "	(206.4)	3/8"-16	11	(3.0)	1000	(4.45)	250	(1.11)	200	(.89)	123	(55.8)
B2127	8 ¹ / ₄ "	(209.5)	3/8"-16	11	(3.0)	1000	(4.45)	250	(1.11)	200	(.89)	125	(56.7)
B2128	8 ³ / ₈ "	(212.7)	3/8"-16	11	(3.0)	1000	(4.45)	250	(1.11)	200	(.89)	126	(57.2)
B2129	8 ¹ / ₂ "	(215.9)	3/8"-16	11	(3.0)	1000	(4.45)	250	(1.11)	200	(.89)	128	(58.1)
B2022	8 ⁵ / ₈ "	(219.1)	3/8"-16	11	(3.0)	1000	(4.45)	250	(1.11)	200	(.89)	128	(58.1)
B2130	10 ³ / ₄ "	(273.0)	3/8"-16	11	(3.0)	1000	(4.45)	250	(1.11)	200	(.89)	160	(72.6)
B2132	12 ³ / ₄ "	(323.8)	3/8"-16	11	(3.0)	1000	(4.45)	250	(1.11)	200	(.89)	185	(83.9)

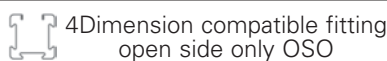

Reference page 168 for general fitting and standard finish specifications.

Pipe Clamps

B1508 thru B1564S Conduit/Strut Clamps

- Safety Factor of 3
- Clamps without saddles are not recommended for flexible conduit or cable
- All Sizes Include:
1/4"-20 slotted hex head machine screw
- Standard finish: ZN

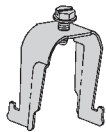
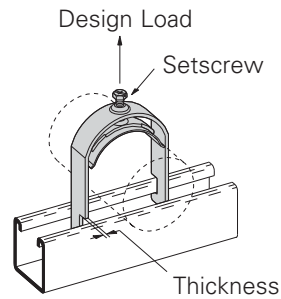

B1508 thru B1520

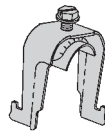

B1508S thru B1524S

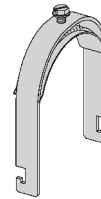

B1532S thru B1564S

Part No.	Use With				Thickness In. mm	Design Load		Wt./C	
	EMT		Rigid Conduit			Lbs.	kN	Lbs.	kg
	In.	mm	In.	mm					
B1508	1/2"	(15)	–	–	16 Ga. (1.5)	200	(.89)	7.4	(3.4)
B1512	3/4"	(20)	1/2"	(15)	16 Ga. (1.5)	200	(.89)	8.0	(3.6)
B1516	1"	(25)	3/4"	(20)	14 Ga. (1.9)	300	(1.33)	11.0	(5.0)
B1520	1 1/4"	(32)	1"	(25)	14 Ga. (1.9)	300	(1.33)	12.5	(5.7)
B1508S	1/2"	(15)	–	–	16 Ga. (1.5)	200	(.89)	8.6	(3.9)
B1512S	3/4"	(20)	1/2"	(15)	16 Ga. (1.5)	200	(.89)	9.2	(4.2)
B1516S	1"	(25)	3/4"	(20)	14 Ga. (1.9)	300	(1.33)	12.7	(5.8)
B1520S	1 1/4"	(32)	1"	(25)	14 Ga. (1.9)	300	(1.33)	14.6	(6.6)
B1524S	1 1/2"	(40)	1 1/4"	(32)	12 Ga. (2.6)	400	(1.78)	20.5	(9.3)
B1532S	2"	(50)	1 1/2"	(40)	12 Ga. (2.6)	400	(1.78)	21.5	(9.8)
B1534S	–	–	2"	(50)	12 Ga. (2.6)	400	(1.78)	22.7	(10.3)
B1540S	2 1/2"	(65)	2 1/2"	(65)	12 Ga. (2.6)	400	(1.78)	26.0	(11.9)
B1548S	3"	(80)	3"	(80)	12 Ga. (2.6)	400	(1.78)	30.2	(13.7)
B1556S	3 1/2"	(90)	3 1/2"	(90)	12 Ga. (2.6)	400	(1.78)	33.3	(15.1)
B1564S	4"	(100)	4"	(100)	12 Ga. (2.6)	400	(1.78)	36.6	(16.6)



4Dimension compatible fitting
open side only OSO

Reference page 168 for general fitting and standard finish specifications.

B2601 thru B2610 TWIST EAR™ Pipe Clamp

- One piece break apart, screw retainer, thread impressions
- Tighter alignment, no need to leave additional space between clamps in order to access nut and bolt
- Easier access bolt can be tightened directly from front
- Available in 1/2", 3/4", 1" rigid and EMT conduit
- Recommended Torque 30 in. - lbs.
- Safety Factor of 3
- Standard finish: ZN

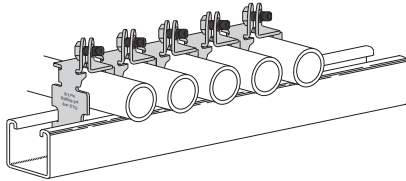

Allows for multiple clamps to be used in succession, with easier access than other pipe clamps.

Design Load

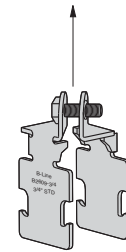

Break-apart - break in the middle, bolt the ends together.

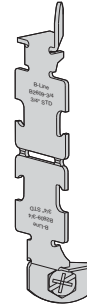

No loose pieces. One piece break apart with screw retainer and thread impressions.

Part No.	Use With		Thickness	Design Load		Wt./C		
	EMT	Rigid Conduit		Lbs.	kN	Lbs.	kg	
	In.	mm	In.	mm				
B2601	1/2"	(17.9)	—	—	300	(1.34)	8.2	(3.7)
B2602	3/4"	(23.4)	—	—	500	(2.24)	13.5	(6.1)
B2603	1"	(29.5)	—	—	500	(2.24)	15.6	(7.1)
B2608	—	—	1/2"	(21.3)	300	(1.34)	8.2	(3.7)
B2609	—	—	3/4"	(26.7)	500	(2.24)	13.5	(6.1)
B2610	—	—	1"	(33.4)	500	(2.24)	15.6	(7.1)

BP081SS thru BP475SS P Clamps

- Minimizes induction heating
- Material: Stainless Steel Type 304

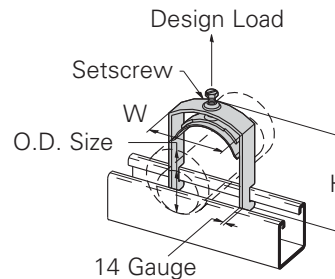

Part No.	O.D. Size		Height H		Width W		Design Load		Wt./C.	
	In.	mm	In.	mm	In.	mm	Lbs.	kN	Lbs.	kg
BP081SS	.250-.840	(6.4-21.3)	1.86	(47.2)	0.87	(22.1)	300	(1.33)	9.0	(4.1)
BP110SS	.810-1.100	(20.6-28.0)	2.18	(55.4)	1.19	(30.2)	300	(1.33)	12.0	(5.4)
BP135SS	.850-1.350	(21.6-34.8)	2.25	(57.2)	1.38	(35.1)	300	(1.33)	14.0	(6.3)
BP175SS	1.250-1.750	(31.8-44.4)	2.78	(70.6)	1.78	(45.2)	300	(1.33)	21.0	(9.5)
BP205SS	1.550-2.050	(39.4-52.1)	3.00	(76.2)	2.28	(57.9)	300	(1.33)	30.0	(13.6)
BP250SS	2.00-2.50	(50.8-63.5)	3.43	(87.1)	2.83	(71.9)	300	(1.33)	35.0	(15.9)
BP300SS	2.55-3.00	(64.7-76.2)	3.87	(97.8)	3.15	(80.0)	300	(1.33)	39.0	(17.7)
BP325SS	2.75-3.25	(69.9-82.8)	4.06	(103.1)	3.28	(83.3)	300	(1.33)	41.0	(18.6)
BP375SS	3.25-3.75	(82.6-95.3)	4.60	(116.8)	3.83	(97.3)	300	(1.33)	47.0	(21.3)
BP425SS	3.75-4.25	(95.3-108.0)	5.13	(130.3)	4.50	(114.3)	300	(1.33)	54.0	(24.4)
BP475SS	4.25-4.75	(108.0-120.7)	5.70	(144.7)	4.85	(123.2)	300	(1.33)	58.0	(26.3)

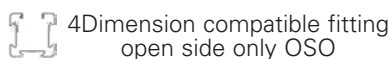

Reference page 168 for general fitting and standard finish specifications.

Vibra-Clamp Pipe Clamps

BVT Series VIBRA-CLAMP™ - Copper & O.D.

- Safety Factor of 3
- Accesses tubing sizes 1/8" (3) to 6" (150)
- Allows easy one tool installation
- Endures both high (+300°F) and low (-40°F) temperatures
- Dampens vibration and noise
- Eliminates galvanic metal to metal contact
- Resists most industrial oils and solvents
- Reduces thermal loss and gain
- Helps secure tubing firmly to channel (strut)
- Dielectric strength of 400 volts/mil
- Includes cushion, clamp, screw and nut
- Standard finishes: YZN, SS4

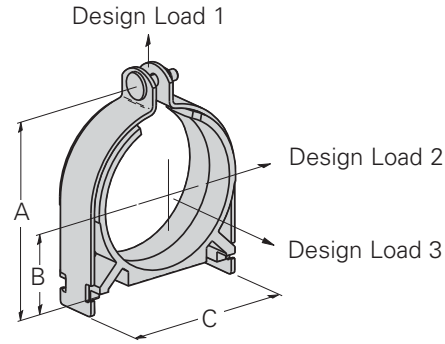

Catalog Number	Tubing O.D. Size		Copper Tubing Size		A		B		C		Wt./C	
	In.	mm	In.	mm	In.	mm	In.	mm	In.	mm	Lbs.	kg
BVT025	1/4"	(6.3)	1/8"	(3)	1.22	(30.9)	0.19	(4.8)	0.49	(12.4)	11	(5.0)
BVT037	3/8"	(9.5)	1/4"	(6)	1.36	(34.5)	0.25	(6.3)	0.61	(15.5)	12	(5.4)
BVT050	1/2"	(12.7)	3/8"	(10)	1.49	(37.8)	0.31	(7.8)	0.74	(18.8)	14	(6.3)
BVT062	5/8"	(15.9)	1/2"	(15)	1.62	(41.1)	0.38	(9.6)	0.86	(21.8)	15	(6.8)
BVT075	3/4"	(19.0)	5/8"	(17)	1.87	(47.4)	0.50	(12.7)	1.15	(29.2)	19	(8.6)
BVT087	7/8"	(22.2)	3/4"	(20)	2.00	(50.8)	0.56	(14.2)	1.27	(32.2)	21	(9.5)
BVT100	1"	(25.4)	-	-	2.25	(57.1)	0.69	(17.5)	1.52	(38.6)	22	(10.0)
BVT112	1 1/8"	(28.6)	1"	(25)	2.25	(57.1)	0.69	(17.5)	1.52	(38.6)	26	(11.8)
BVT125	1 1/4"	(31.7)	-	-	2.51	(63.7)	0.81	(20.6)	1.78	(45.2)	36	(16.3)
BVT137	1 3/8"	(34.9)	1 1/4"	(32)	2.51	(63.7)	0.81	(20.6)	1.78	(45.2)	38	(17.2)
BVT150	1 1/2"	(38.1)	-	-	2.74	(69.6)	0.88	(22.4)	1.96	(49.8)	35	(15.9)
BVT162	1 5/8"	(41.3)	1 1/2"	(40)	3.00	(76.2)	1.00	(25.4)	2.20	(55.9)	40	(18.1)
BVT175	1 3/4"	(44.4)	-	-	3.13	(79.5)	1.06	(26.9)	2.33	(59.1)	44	(19.9)
BVT187	1 7/8"	(47.6)	-	-	3.28	(83.3)	1.13	(28.7)	2.46	(62.5)	40	(18.1)
BVT200	2"	(50.8)	-	-	3.52	(89.4)	1.25	(31.7)	2.70	(68.6)	55	(25.0)
BVT212	2 1/8"	(54.0)	2"	(50)	3.52	(89.4)	1.25	(31.7)	2.70	(68.6)	55	(25.0)
BVT225	2 1/4"	(57.1)	-	-	3.64	(92.4)	1.31	(33.2)	2.83	(71.8)	54	(24.5)
BVT250	2 1/2"	(63.5)	-	-	3.91	(99.3)	1.43	(36.3)	3.11	(79.0)	56	(25.4)
BVT262	2 5/8"	(66.6)	2 1/2"	(65)	4.02	(102.1)	1.50	(38.1)	3.20	(81.3)	55	(25.0)
BVT300	3"	(76.2)	-	-	4.42	(112.2)	1.68	(42.6)	3.61	(91.6)	67	(30.4)
BVT312	3 1/8"	(79.4)	3"	(80)	4.53	(115.0)	1.75	(44.4)	3.70	(93.9)	64	(29.0)
BVT362	3 5/8"	(92.1)	3 1/2"	(90)	5.05	(128.2)	2.00	(50.8)	4.23	(107.4)	76	(34.5)
BVT412	4 1/8"	(104.8)	4"	(100)	5.55	(140.9)	2.25	(57.1)	4.73	(120.1)	93	(42.2)
BVT612	6 1/8"	(155.5)	6"	(150)	7.62	(193.5)	3.25	(82.5)	6.74	(171.1)	136	(61.6)

Catalog Number	Design Load 1		Design Load 2		Design Load 3	
	Lbs.	kN	Lbs.	kN	Lbs.	kN
BVT025	400	(1.78)	50	(0.22)	50	(0.22)
BVT037	400	(1.78)	50	(0.22)	50	(0.22)
BVT050	400	(1.78)	50	(0.22)	50	(0.22)
BVT062	400	(1.78)	50	(0.22)	50	(0.22)
BVT075	600	(2.67)	75	(0.33)	75	(0.33)
BVT087	600	(2.67)	75	(0.33)	75	(0.33)
BVT100	600	(2.67)	75	(0.33)	75	(0.33)
BVT112	600	(2.67)	75	(0.33)	75	(0.33)
BVT125	600	(2.67)	75	(0.33)	75	(0.33)
BVT137	600	(2.67)	75	(0.33)	75	(0.33)
BVT150	600	(2.67)	75	(0.33)	75	(0.33)
BVT162	800	(3.56)	125	(0.56)	125	(0.56)
BVT175	800	(3.56)	125	(0.56)	125	(0.56)
BVT187	800	(3.56)	125	(0.56)	125	(0.56)
BVT200	800	(3.56)	125	(0.56)	125	(0.56)
BVT212	800	(3.56)	125	(0.56)	125	(0.56)
BVT225	800	(3.56)	125	(0.56)	125	(0.56)
BVT250	800	(3.56)	125	(0.56)	125	(0.56)
BVT262	800	(3.56)	125	(0.56)	125	(0.56)
BVT300	800	(3.56)	125	(0.56)	125	(0.56)
BVT312	800	(3.56)	125	(0.56)	125	(0.56)
BVT362	1000	(4.45)	200	(0.89)	150	(0.67)
BVT412	1000	(4.45)	200	(0.89)	150	(0.67)
BVT612	1000	(4.45)	200	(0.89)	150	(0.67)

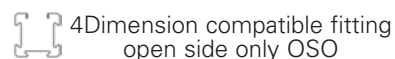

Reference page 168 for general fitting and standard finish specifications.

Vibra-Clamp Pipe Clamps

BVP Series VIBRA-CLAMP™ - Iron Pipe & Rigid Conduit

- Safety Factor of 3
- Accesses pipe sizes 1/4" (6) to 6" (150)
- Allows easy one tool installation
- Endures both high (+300°F) and low (-40°F) temperatures
- Dampens vibration and noise
- Eliminates galvanic metal to metal contact
- Resists most industrial oils and solvents
- Reduces thermal loss and gain
- Helps secure pipe firmly to channel (strut)
- Dielectric strength of 400 volts/mil
- Includes cushion, clamp, screw and nut
- Standard finishes: YZN, SS4

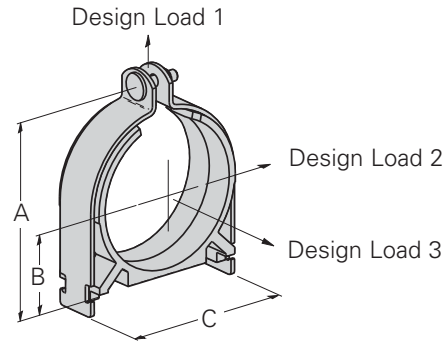

Catalog Number	Nominal Pipe Size		Steel O.D. Size		A		B		C		Wt./C	
	In.	mm	In.	mm	In.	mm	In.	mm	In.	mm	Lbs.	kg
BVP025	1/4"	(6.3)	0.540	(13.7)	1.61	(39.9)	0.37	(9.4)	0.87	(22.1)	15	(6.8)
BVP037	3/8"	(9.5)	0.675	(17.1)	1.86	(47.2)	0.50	(12.7)	1.15	(29.2)	18	(8.2)
BVP050	1/2"	(12.7)	0.875	(22.2)	1.99	(50.5)	0.56	(14.2)	1.27	(32.3)	20	(9.1)
BVP075	3/4"	(19.0)	1.050	(26.7)	2.25	(57.1)	0.69	(17.5)	1.52	(38.6)	21	(9.5)
BVP100	1"	(25.4)	1.312	(33.3)	2.51	(63.8)	0.81	(20.6)	1.77	(45.0)	20	(9.1)
BVP125	1 1/4"	(31.7)	1.660	(42.2)	3.00	(76.2)	1.00	(25.4)	2.21	(56.1)	36	(16.3)
BVP150	1 1/2"	(38.1)	1.900	(48.3)	3.21	(83.1)	1.12	(28.4)	2.41	(62.3)	40	(18.1)
BVP200	2"	(50.8)	2.375	(60.3)	3.77	(95.8)	1.37	(34.8)	2.96	(75.2)	45	(20.4)
BVP250	2 1/2"	(63.5)	2.875	(73.0)	4.28	(108.7)	1.62	(41.1)	3.46	(87.9)	54	(24.5)
BVP300	3"	(76.2)	3.500	(88.9)	5.05	(128.3)	2.00	(50.8)	4.24	(107.7)	81	(36.7)
BVP350	3 1/2"	(88.9)	4.000	(101.6)	5.55	(140.9)	2.25	(57.1)	4.74	(120.3)	87	(39.4)
BVP400	4"	(101.6)	4.500	(114.3)	6.05	(153.7)	2.50	(63.5)	5.24	(133.1)	109	(49.4)
BVP500	5"	(127.0)	5.563	(141.3)	6.84	(173.7)	3.00	(76.2)	6.24	(158.4)	136	(61.6)
BVP600	6"	(152.4)	6.625	(168.3)	8.24	(209.3)	3.56	(90.4)	7.36	(186.9)	163	(73.8)

Pipe/Conduit Clamps & Hangers

Catalog Number	Design Load 1		Design Load 2		Design Load 3	
	Lbs. 1	kN	Lbs. 2	kN	Lbs. 3	kN
BVP025	400	(1.78)	50	(0.22)	50	(0.22)
BVP037	600	(2.67)	75	(0.33)	75	(0.33)
BVP050	600	(2.67)	75	(0.33)	75	(0.33)
BVP075	600	(2.67)	75	(0.33)	75	(0.33)
BVP100	600	(2.67)	75	(0.33)	75	(0.33)
BVP125	800	(3.56)	125	(0.56)	125	(0.56)
BVP150	800	(3.56)	125	(0.56)	125	(0.56)
BVP200	800	(3.56)	125	(0.56)	125	(0.56)
BVP250	800	(3.56)	125	(0.56)	125	(0.56)
BVP300	1000	(4.45)	200	(0.89)	150	(0.67)
BVP350	1000	(4.45)	200	(0.89)	150	(0.67)
BVP400	1000	(4.45)	200	(0.89)	150	(0.67)
BVP500	1000	(4.45)	200	(0.89)	150	(0.67)
BVP600	1000	(4.45)	200	(0.89)	150	(0.67)



Reference page 168 for general fitting and standard finish specifications.

Armafix™ Clamps & Accessories

IPH Series

Inserted - Inserts with Clamps

- Engineered load-bearing inserts prevents insulation compression
- Innovative insulated pipe support
- Desirable "Foam-to-Foam" bond
- Service temperature range
-58°F (-50°C) to +220°F (+105°C)



Insert Only



Assembly
Insert & Clamp



3/4" Wall Insulation Thickness

Assembly Part No.	Insert Only Part No.	Pipe/Copper/OD Size	Hanger Size*
IPH03834	IPH03834WO	3/8" O.D.	2"
IPH01234	IPH01234WO	1/2" O.D.	2"
IPH05834	IPH05834WO	5/8" O.D.	2"
IPH07834	IPH07834WO	3/4" O.D. & 7/8" O.D.	2 1/2"
IPH11834	IPH11834WO	3/4" IPS & 1 1/8" O.D.	2 1/2"
IPH13834	IPH13834WO	1 3/8" O.D.	3"
IPH15834	IPH15834WO	1 5/8" O.D.	3 1/2"
IPH11034	IPH11034WO	1 1/2" IPS & 1 7/8" O.D.	3 1/2"
IPH21834	IPH21834WO	2 1/8" O.D.	4"
IPH25834	IPH25834WO	2 5/8" O.D.	5"
IPH31834	IPH31834WO	3 1/8" O.D.	5"
IPH35834	IPH35834WO	3 5/8" O.D.	6"
IPH41834	IPH41834WO	4 1/8" O.D.	6"
IPH40034	IPH40034WO	4" IPS	6"
IPH50034	IPH50034WO	5" IPS	8"
IPH60034	IPH60034WO	6" IPS	10"
IPH80034	IPH80034WO	8" IPS	12"

* Recommended pipe hanger size for insulation thickness shown. (Order hanger separately)

IPH18230 ARMAFLEX®† Insulation Tape

- 30 ft. (9.14 M) roll



†Armaflex® is a registered trademark of Armacell.



4Dimension compatible fitting
open side only OSO

Reference page 168 for general fitting and standard finish specifications.

1/2" Wall Insulation Thickness

Assembly Part No.	Insert Only Part No.	Pipe/Copper/OD Size	Hanger Size*
IPH03812	IPH03812WO	3/8" O.D.	1 1/4"
IPH01212	IPH01212WO	1/2" O.D.	1 1/4"
IPH05812	IPH05812WO	5/8" O.D.	1 1/2"
IPH07812	IPH07812WO	3/4" O.D. & 7/8" O.D.	2"
IPH11812	IPH11812WO	3/4" IPS & 1 1/8" O.D.	2"
IPH13812	IPH13812WO	1 3/8" O.D.	2 1/2"
IPH15812	IPH15812WO	1 5/8" O.D.	2 1/2"
IPH11012	IPH11012WO	1 1/2" IPS & 1 7/8" O.D.	3"
IPH21812	IPH21812WO	2 1/8" O.D.	3"
IPH25812	IPH25812WO	2 5/8" O.D.	3 1/2"
IPH31812	IPH31812WO	3 1/8" O.D.	4"
IPH35812	IPH35812WO	3 5/8" O.D.	5"
IPH41812	IPH41812WO	4 1/8" O.D.	6"
IPH40012	IPH40012WO	4" IPS	6"
IPH50012	IPH50012WO	5" IPS	8"
IPH60012	IPH60012WO	6" IPS	8"

* Recommended pipe hanger size for insulation thickness shown. (Order hanger separately)

1" Wall Insulation Thickness

Assembly Part No.	Insert Only Part No.	Pipe/Copper/OD Size	Hanger Size*
IPH05810	IPH05810WO	5/8" O.D.	2 1/2"
IPH07810	IPH07810WO	3/4" O.D. & 7/8" O.D.	3"
IPH11810	IPH11810WO	3/4" IPS & 1 1/8" O.D.	3"
IPH13810	IPH13810WO	1 3/8" O.D.	3 1/2"
IPH15810	IPH15810WO	1 5/8" O.D.	3 1/2"
IPH11010	IPH11010WO	1 1/2" IPS & 1 7/8" O.D.	4"
IPH21810	IPH21810WO	2 1/8" O.D.	4"
IPH25810	IPH25810WO	2 5/8" O.D.	5"
IPH31810	IPH31810WO	3 1/8" O.D.	5"
IPH35810	IPH35810WO	3 5/8" O.D.	6"
IPH41810	IPH41810WO	4 1/8" O.D.	6"
IPH40010	IPH40010WO	4" IPS	8"
IPH50010	IPH50010WO	5" IPS	8"
IPH60010	IPH60010WO	6" IPS	10"
IPH80010	IPH80010WO	8" IPS	12"

* Recommended pipe hanger size for insulation thickness shown. (Order hanger separately)

B1999 VIBRA-CUSHION

- Packaged 20 Ft. (6.09 m) per carton
- Ideal isolation material
- Inhibits galvanic corrosion
- Dampens sound and vibrations
- Service Temperature Range
-75°F (-60°C) to +375°F (+199°C)
- Wt./Carton 3.8 Lbs. (1.7 kg)

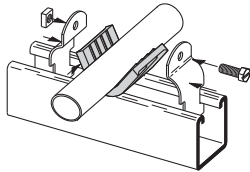

Features

Vibra-Cushion™ is designed for use with refrigeration lines, HVAC, copper tubing, glass pipe and hydraulic lines. It provides an energy-absorption barrier between the lines and the mounting material and remains flexible thru its entire service range of -75°F (-60°C) to +375°F (+199°C).

This elastomer allows for expansion and contraction within the mounting system and prevents galvanic reaction between dissimilar metals.

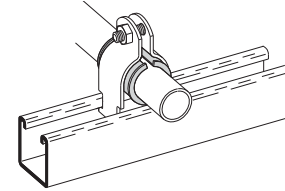

For Rigid Conduit or Iron Pipe

Nominal Size In. mm	Length*		Use Clamp No.
	In.	mm	
3/8" (10)	2 1/8"	(54.0)	B2002
1/2" (15)	2 5/8"	(66.7)	B2009
3/4" (20)	3 1/4"	(82.5)	B2031
1" (25)	4 1/8"	(104.8)	B2004
1 1/4" (32)	5 3/16"	(131.8)	B2012
1 1/2" (40)	5 15/16"	(150.8)	B2038
2" (50)	7 1/2"	(190.5)	B2042
2 1/2" (65)	9"	(228.6)	B2046
3" (80)	11"	(279.4)	B2051
3 1/2" (90)	12 1/2"	(317.5)	B2055
4" (100)	14 1/2"	(368.3)	B2059
5" (125)	17 7/16"	(442.9)	B2067
6" (150)	20 3/4"	(527.0)	B2116

* Length of Vibra-Cushion

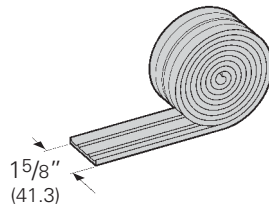

For Thinwall (EMT) Conduit

Nominal Size In. mm	Length*		Use Clamp No.
	In.	mm	
3/8" (10)	1 13/16"	(46.0)	B2027
1/2" (15)	2 13/16"	(58.7)	B2002
3/4" (20)	2 7/8"	(73.0)	B2003
1" (25)	3 5/8"	(92.1)	B2032
1 1/4" (32)	4 3/8"	(120.6)	B2036
1 1/2" (40)	5 7/16"	(138.1)	B2012
2" (50)	6 7/8"	(174.6)	B2013

* Length of Vibra-Cushion

For Copper Tubing Type L & K

Nominal Size In. mm	Length*		Use Clamp No.
	In.	mm	
1/4" (6)	1 3/16"	(30.2)	B2026
3/8" (10)	1 9/16"	(39.7)	B2027
1/2" (15)	1 7/8"	(47.6)	B2008
5/8" (17)	2 5/16"	(58.7)	B2009
3/4" (20)	2 3/4"	(69.8)	B2030
1" (25)	3 1/2"	(88.9)	B2010
1 1/4" (32)	4 5/16"	(109.5)	B2011
1 1/2" (40)	5 1/8"	(130.2)	B2012
2" (50)	6 11/16"	(169.9)	B2013
2 1/2" (65)	8 1/4"	(209.5)	B2014
3" (80)	9 13/16"	(249.2)	B2048
3 1/2" (90)	11 3/8"	(288.9)	B2052
4" (100)	12 15/16"	(328.6)	B2056
5" (125)	16 1/8"	(409.6)	B2064
6" (150)	19 1/4"	(488.9)	B2112
8" (200)	25 1/2"	(647.7)	B2128

* Length of Vibra-Cushion

ISO Pipe Isolator

- Non-adhesive rubber tape
- Fuses to itself
- Water resistant
- Ideal Isolation material
- Prevents galvanic reaction caused by dissimilar metal contact
- Temperature Range
-140°F (-60°C) to +395°F (+200°C)

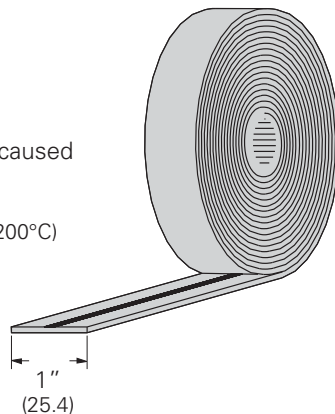

Part No.	Thickness		Ft./Roll Ft. m
	In.	mm	
ISO	.020	(0.5)	36 (11)

BVS Type - Vibra Strip™ for 1 5/8" (41.3) wide B-Line channel

- Fits securely in 1 5/8" wide channel
- Temperature range: -20°F to 212°F
- Ideal isolation & vibration dampening qualities
- 45 durometer hardness
- Material: Neoprene

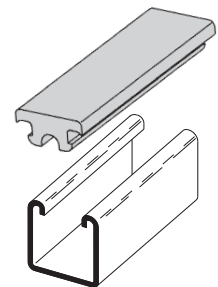

Part No.	Max. Load Lbs. per Lineal In.		Length		Std. Pkg.	Wt. Each	
	Lbs.	kg/25.4 mm	In.	mm		Lbs.	kg
BVS-12	40	(18.1)	12"	(304.8)	25	.46	(.21)
BVS-120	40	(18.1)	120"	(3048.0)	25	4.60	(2.08)

Reference page 168 for general fitting and standard finish specifications.

Pipe Clamps

B2400 Series Standard Pipe Clamp

- Safety Factor of 5
- B2400-3/4 thru B2400-8 are UL listed
- Order hardware separately
- Other sizes available upon request
- Material: Sizes - 1/2" - 1 1/2", ASTM A1011 33,000 PSI min. yield;
2" - 12", ASTM A1018 33,000 PSI min. yield;
14"-Larger, ASTM A36
- Standard finish: ZN
- Ductile iron sizes available
- Meets requirements of MSS SP-58 & SP-69 Type 26

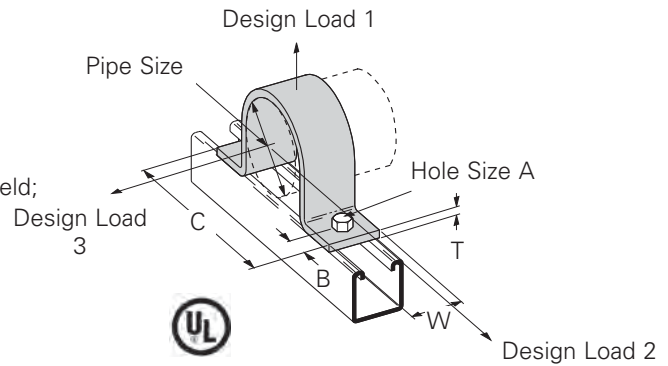

Part No.	Pipe Size		A		B		C		T		W	
	In.	mm	In.	mm	In.	mm	In.	mm	In.	mm	In.	mm
B2400-1/2	1/2"	(15)	5/16"	(7.9)	7/16"	(11.1)	2 13/16"	(71.4)	10 Ga.	(3.4)	1 5/8"	(41.3)
B2400-3/4	3/4"	(20)	5/16"	(7.9)	7/16"	(11.1)	3"	(76.2)	10 Ga.	(3.4)	1 5/8"	(41.3)
B2400-1	1"	(25)	5/16"	(7.9)	7/16"	(11.1)	3 17/32"	(89.7)	10 Ga.	(3.4)	1 5/8"	(41.3)
B2400-1 1/4	1 1/4"	(32)	5/16"	(7.9)	7/16"	(11.1)	3 3/4"	(95.2)	10 Ga.	(3.4)	1 5/8"	(41.3)
B2400-1 1/2	1 1/2"	(40)	5/16"	(7.9)	7/16"	(11.1)	4 1/16"	(103.2)	10 Ga.	(3.4)	1 5/8"	(41.3)
B2400-2	2"	(50)	7/16"	(11.1)	1 1/16"	(17.4)	5 21/32"	(143.6)	1/4"	(6.3)	1 5/8"	(41.3)
B2400-2 1/2	2 1/2"	(65)	7/16"	(11.1)	1 1/16"	(17.4)	6 5/32"	(156.3)	1/4"	(6.3)	1 5/8"	(41.3)
B2400-3	3"	(80)	7/16"	(11.1)	1 1/16"	(17.4)	6 25/32"	(172.2)	1/4"	(6.3)	1 5/8"	(41.3)
B2400-3 1/2	3 1/2"	(90)	7/16"	(11.1)	1 1/16"	(17.4)	7 9/32"	(184.9)	1/4"	(6.3)	1 5/8"	(41.3)
B2400-4	4"	(100)	9/16"	(14.3)	1 1/16"	(17.4)	7 25/32"	(197.6)	1/4"	(6.3)	1 5/8"	(41.3)
B2400-5	5"	(125)	9/16"	(14.3)	1 1/16"	(17.4)	8 7/8"	(225.4)	1/4"	(6.3)	1 5/8"	(41.3)
B2400-6	6"	(150)	9/16"	(14.3)	1 1/16"	(17.4)	9 15/16"	(252.4)	1/4"	(6.3)	1 5/8"	(41.3)
B2400-8	8"	(200)	9/16"	(14.3)	1 1/16"	(17.4)	11 31/32"	(304.0)	1/4"	(6.3)	1 5/8"	(41.3)
B2400-10	10"	(250)	9/16"	(14.3)	1 1/16"	(17.4)	14"	(355.6)	1/4"	(6.3)	1 5/8"	(41.3)
B2400-12	12"	(300)	9/16"	(14.3)	1 1/16"	(17.4)	16"	(406.4)	1/4"	(6.3)	1 5/8"	(41.3)
B2400-14	14"	(350)	1 5/16"	(23.8)	1 1/2"	(38.1)	20 3/4"	(527.0)	3/8"	(9.5)	1 3/4"	(44.4)
B2400-16	16"	(400)	1 5/16"	(23.8)	1 1/2"	(38.1)	22 3/4"	(577.8)	3/8"	(9.5)	1 3/4"	(44.4)
B2400-18	18"	(460)	1 5/16"	(23.8)	1 3/4"	(44.4)	27"	(685.8)	1/2"	(12.7)	1 3/4"	(44.4)
B2400-20	20"	(510)	1 5/16"	(23.8)	1 3/4"	(44.4)	29"	(736.6)	1/2"	(12.7)	1 3/4"	(44.4)
B2400-24	24"	(610)	1 5/16"	(23.8)	1 3/4"	(44.4)	33"	(838.2)	1/2"	(12.7)	1 3/4"	(44.4)

Part No.	Design Load 1		Design Load 2		Design Load 3		Wt./C	
	Lbs.	kN	Lbs.	kN	Lbs.	kN	Lbs.	kg
B2400-1/2	600	(2.67)	150	(.67)	105	(.47)	23	(10.4)
B2400-3/4	600	(2.67)	150	(.67)	105	(.47)	26	(11.8)
B2400-1	600	(2.67)	150	(.67)	120	(.53)	31	(14.0)
B2400-1 1/4	600	(2.67)	150	(.67)	120	(.53)	36	(16.3)
B2400-1 1/2	600	(2.67)	150	(.67)	120	(.53)	39	(17.7)
B2400-2	1200	(5.34)	480	(2.14)	180	(.80)	93	(42.2)
B2400-2 1/2	1200	(5.34)	480	(2.14)	180	(.80)	106	(48.1)
B2400-3	1200	(5.34)	480	(2.14)	300	(1.33)	132	(59.9)
B2400-3 1/2	1200	(5.34)	480	(2.14)	300	(1.33)	151	(68.5)
B2400-4	1500	(6.67)	600	(2.67)	450	(2.00)	160	(72.6)
B2400-5	1500	(6.67)	600	(2.67)	450	(2.00)	192	(87.1)
B2400-6	1500	(6.67)	600	(2.67)	450	(2.00)	219	(99.3)
B2400-8	2000	(8.90)	800	(3.56)	600	(2.67)	297	(134.7)
B2400-10	2000	(8.90)	800	(3.56)	600	(2.67)	465	(210.9)
B2400-12	2000	(8.90)	800	(3.56)	600	(2.67)	560	(254.0)
B2400-14	2000	(8.90)	800	(3.56)	600	(2.67)	761	(345.2)
B2400-16	2000	(8.90)	800	(3.56)	600	(2.67)	861	(390.5)
B2400-18	2000	(8.90)	800	(3.56)	600	(2.67)	1297	(588.3)
B2400-20	2000	(8.90)	800	(3.56)	600	(2.67)	1426	(646.8)
B2400-24	2000	(8.90)	800	(3.56)	600	(2.67)	1682	(762.9)

4Dimension compatible fitting

Reference page 168 for general fitting and standard finish specifications.

B437 Series Two Piece Pipe Clamp

- Clamp halves can turn allowing pipe to be fastened to channel at any direction
- Order hardware separately
- Standard finish: ZN



Part No.	Pipe Size		A		T		Wt./C	
	In.	mm	In.	mm	In.	mm	Lbs.	kg
B437-1/2	1/2"	(15)	5/16"	(7.9)	10 Ga.	(3.4)	22	(10.0)
B437-3/4	3/4"	(20)	5/16"	(7.9)	10 Ga.	(3.4)	26	(11.8)
B437-1	1"	(25)	5/16"	(7.9)	10 Ga.	(3.4)	30	(13.6)
B437-1 1/4	1 1/4"	(32)	5/16"	(7.9)	10 Ga.	(3.4)	35	(15.9)
B437-1 1/2	1 1/2"	(40)	5/16"	(7.9)	10 Ga.	(3.4)	38	(17.2)
B437-2	2"	(50)	7/16"	(11.1)	1/4"	(6.3)	91	(41.3)
B437-2 1/2	2 1/2"	(65)	7/16"	(11.1)	1/4"	(6.3)	104	(47.2)
B437-3	3"	(80)	7/16"	(11.1)	1/4"	(6.3)	130	(58.9)
B437-3 1/2	3 1/2"	(90)	7/16"	(11.1)	1/4"	(6.3)	149	(67.6)
B437-4	4"	(100)	9/16"	(11.1)	1/4"	(6.3)	158	(71.6)
B437-5	5"	(125)	9/16"	(11.1)	1/4"	(6.3)	190	(86.2)
B437-6	6"	(150)	9/16"	(11.1)	1/4"	(6.3)	217	(98.4)
B437-8	8"	(200)	9/16"	(11.1)	1/4"	(6.3)	295	(133.8)

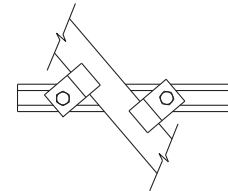
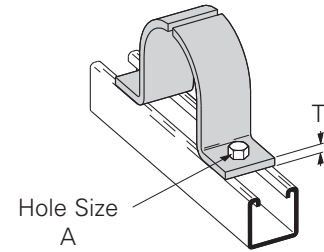

B2417 Strut Mounted Pipe Guide

- Copper tubing sizes available - B2417CT Series
- Standard finish: ZN



Part No.	Pipe Size		Minimum Radial Clearance		Includes Clamp No.	Wt./C	
	In.	mm	In.	mm		Lbs.	kg
B2417-1/2	1/2"	(15)	1/16"	(1.6)	B2009	22	(10.0)
B2417-3/4	3/4"	(20)	1/16"	(1.6)	B2010	25	(11.3)
B2417-1	1"	(25)	3/32"	(2.3)	B2034	30	(13.6)
B2417-1 1/4	1 1/4"	(32)	3/32"	(2.3)	B2037	47	(21.8)
B2417-1 1/2	1 1/2"	(40)	3/32"	(2.3)	B2039	51	(23.1)
B2417-2	2"	(50)	1/8"	(3.2)	B2043	62	(28.1)
B2417-2 1/2	2 1/2"	(65)	1/8"	(3.2)	B2047	69	(31.3)
B2417-3	3"	(80)	5/32"	(3.9)	B2016	108	(49.0)
B2417-3 1/2	3 1/2"	(90)	5/32"	(3.9)	B2017	118	(53.5)
B2417-4	4"	(100)	5/32"	(3.9)	B2018	128	(58.0)

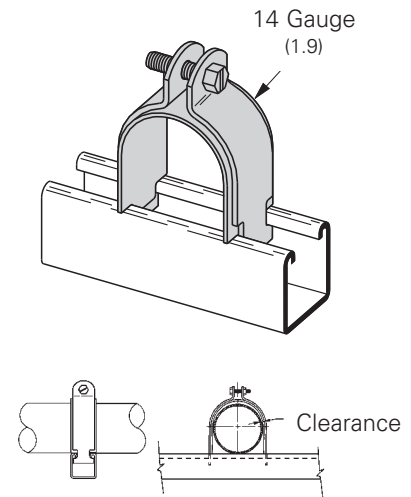

B2070 thru B2080 Parallel Pipe Clamp

- Safety Factor of 2
- Designed to support pipe or rigid conduit
- Includes:
 - 1 pr. pipe clamps
 - 1 pc. stand off plate
 - 1 pc. hotted hex head machine screws
 - 1 pc. Square Nut
- Standard finish: ZN

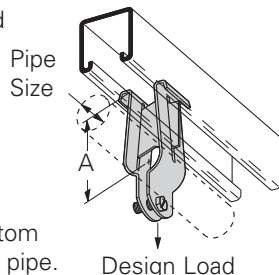

A dimension, from bottom of channel to center of pipe.

Part No.	Pipe Size		A		Material Thickness		Design Load		Wt./C	
	In.	mm	In.	mm	In.	mm	Lbs.	kN	Lbs.	kg
B2070	3/8"	(10)	1 1/16"	(42.9)	16 Ga.	(1.5)	300	(1.33)	24	(10.9)
B2071	1/2"	(15)	1 3/4"	(44.4)	16 Ga.	(1.5)	300	(1.33)	26	(11.8)
B2072	3/4"	(20)	1 7/8"	(47.6)	14 Ga.	(1.9)	300	(1.33)	30	(13.6)
B2073	1"	(25)	2"	(50.8)	14 Ga.	(1.9)	400	(1.78)	33	(14.9)
B2074	1 1/4"	(32)	2 3/16"	(55.6)	14 Ga.	(1.9)	400	(1.78)	36	(16.3)
B2075	1 1/2"	(40)	2 5/16"	(58.7)	12 Ga.	(2.6)	500	(2.22)	50	(22.7)
B2076	2"	(50)	2 9/16"	(65.1)	12 Ga.	(2.6)	500	(2.22)	55	(24.9)
B2077	2 1/2"	(65)	2 7/8"	(73.0)	12 Ga.	(2.6)	500	(2.22)	60	(27.2)
B2078	3"	(80)	3 3/16"	(80.9)	12 Ga.	(2.6)	500	(2.22)	66	(29.9)
B2079	3 1/2"	(90)	3 7/16"	(87.3)	11 Ga.	(3.0)	500	(2.22)	85	(38.5)
B2080	4"	(100)	3 5/8"	(92.1)	11 Ga.	(3.0)	500	(2.22)	95	(43.1)

4Dimension compatible fitting

Reference page 168 for general fitting and standard finish specifications.

Pipe Clamps

B670 Series Parallel Pipe Clamp

- Designed to support pipe or rigid conduit parallel to the edge of a beam or angle iron
- Hardware included
- Material: Malleable iron
- Standard finish: HDG

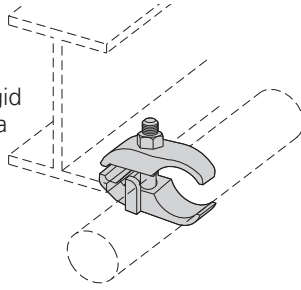

Part Number	Pipe/Conduit Size		Wt./C	
	In.	mm	Lbs.	kg
B670-3/8	3/8"	(10)	32	(14.5)
B670-1/2	1/2"	(15)	58	(26.3)
B670-3/4	3/4"	(20)	64	(29.0)
B670-1	1"	(25)	70	(31.7)
B670-1 1/4	1 1/4"	(32)	77	(34.9)
B670-1 1/2	1 1/2"	(40)	93	(42.2)
B670-2	2"	(50)	105	(47.6)
B670-2 1/2	2 1/2"	(65)	143	(64.8)
B670-3	3"	(80)	164	(74.4)
B670-3 1/2	3 1/2"	(90)	190	(86.2)
B670-4	4"	(100)	205	(93.0)

B671 Series Edge Pipe Clamp

- Designed to support pipe or rigid conduit perpendicular to the edge of a beam or angle iron
- Hardware included
- Material: Malleable iron
- Standard finish: HDG

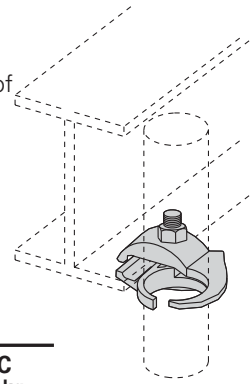

Part Number	Pipe/Conduit Size		Wt./C	
	In.	mm	Lbs.	kg
B671-1/2	1/2"	(15)	67	(30.4)
B671-3/4	3/4"	(20)	71	(32.2)
B671-1	1"	(25)	85	(38.5)
B671-1 1/4	1 1/4"	(32)	91	(41.3)
B671-1 1/2	1 1/2"	(40)	115	(52.1)
B671-2	2"	(50)	135	(61.2)
B671-2 1/2	2 1/2"	(65)	183	(83.0)
B671-3	3"	(80)	230	(104.3)

B422 Series Right Angle Clamp

- Safety Factor of 5
- Material: 7 gauge (4.5)
- Standard finishes: ZN, SS4

Part No.	Conduit Size		A		Design Load Vertical Pull Lbs. kN	Wt./C	
	In.	mm	In.	mm		Lbs.	kg
B422-1/2	1/2"	(15)	2 3/8"	(60.3)	250 (1.11)	38	(17.2)
B422-3/4	3/4"	(20)	2 3/8"	(60.3)	300 (1.33)	39	(17.7)
B422-1	1"	(25)	2 7/8"	(73.0)	400 (1.78)	48	(21.8)
B422-1 1/4	1 1/4"	(32)	2 7/8"	(73.0)	400 (1.78)	50	(22.7)
B422-1 1/2	1 1/2"	(40)	3 1/4"	(82.5)	500 (2.22)	59	(26.7)
B422-2	2"	(50)	3 11/16"	(93.7)	600 (2.67)	75	(34.0)
B422-2 1/2	2 1/2"	(65)	4 1/4"	(107.9)	700 (3.11)	98	(44.4)
B422-3	3"	(80)	4 7/8"	(123.8)	800 (3.56)	111	(50.3)
B422-3 1/2	3 1/2"	(90)	5 7/16"	(138.1)	900 (4.00)	123	(55.8)
B422-4	4"	(100)	6"	(152.4)	1000 (4.45)	135	(61.2)

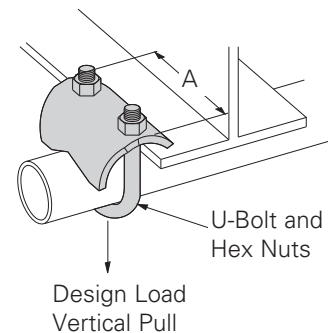

B3367S Retaining Strap

- Available in 'L' lengths of 6" (152.4), 8" (203.2), 9" (228.6), 10" (254.0), 12" (304.8), 14" (355.6), 16" (406.4), 18" (457.2)
- Material: Steel
- Standard finishes: ZN, PLN

Part No.	For Use With	Wt./C**	
		Lbs.	kg
B3367S-1-L	B422-1/2 & 3/4	33.4	(5.8)
B3367S-2-L	B422-1, 1 1/4 & 1 1/2	12.8	(15.1)

** Wt./C based on 6" (152.4) length. For each additional inch in strap length add the following to the Wt./C.
 For B3367S-1 add 5.7 Lbs (2.6 kg)
 For B3367S-2 add 2.2 Lbs (1.0 kg)

Note: Use Fig. 69 (Old B3367-3/8 retaining strap, page 116) for B422-2 thru 4

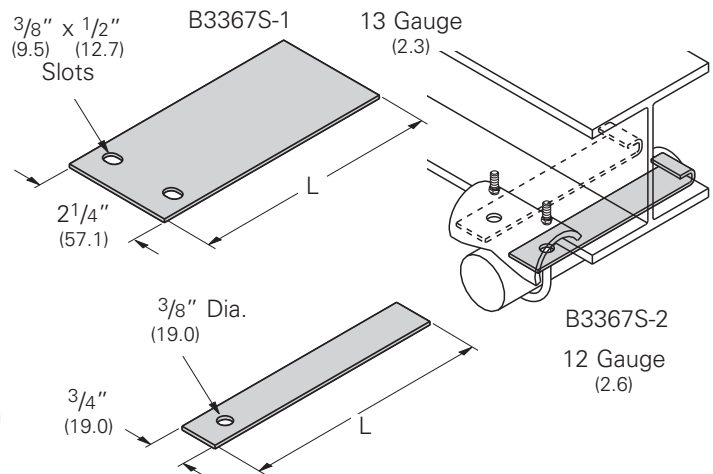

Reference page 168 for general fitting and standard finish specifications.

B2301 Series One Hole EMT Strap

- Standard finish: ZN

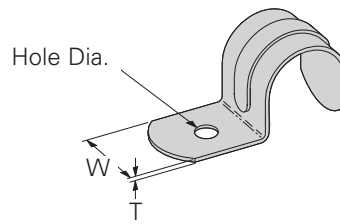

Part No.	Conduit Size		T		W		Hole Dia.		Wt./C	
	In.	mm	In.	mm	In.	mm	In.	mm	Lbs.	kg
B2301-1/2	1/2"	(15)	.050	(1.3)	3/4"	(19.0)	9/32"	(7.1)	2.4	(1.1)
B2301-3/4	3/4"	(20)	.050	(1.3)	7/8"	(22.2)	9/32"	(7.1)	4.2	(1.9)
B2301-1	1"	(25)	.050	(1.3)	1"	(25.4)	9/32"	(7.1)	8.3	(3.7)
B2301-1 1/4	1 1/4"	(32)	.065	(1.6)	1 1/4"	(31.7)	9/32"	(7.1)	11.0	(5.0)
B2301-1 1/2	1 1/2"	(40)	.090	(2.3)	1"	(25.4)	1 1/32"	(8.7)	14.8	(6.7)
B2301-2	2"	(50)	.090	(2.3)	1 1/4"	(31.7)	1 3/32"	(10.3)	21.6	(9.8)

B2302 Series One Hole Rigid Conduit/Pipe Strap

- Standard finish: ZN

Part No.	Conduit/Pipe Size		T		W		Hole Dia.		Wt./C	
	In.	mm	In.	mm	In.	mm	In.	mm	Lbs.	kg
B2302-1/4	1/4"	(6)	.045	(1.1)	5/8"	(15.9)	13/64"	(5.1)	1.4	(.6)
B2302-3/8	3/8"	(10)	.050	(1.3)	3/4"	(19.0)	9/32"	(7.1)	2.4	(1.1)
B2302-1/2	1/2"	(15)	.050	(1.3)	7/8"	(22.2)	9/32"	(7.1)	3.3	(1.5)
B2302-3/4	3/4"	(20)	.050	(1.3)	7/8"	(22.2)	9/32"	(7.1)	3.8	(1.7)
B2302-1	1"	(25)	.065	(1.6)	1"	(25.4)	9/32"	(7.1)	7.2	(3.2)
B2302-1 1/4	1 1/4"	(32)	.065	(1.6)	1 1/4"	(31.7)	2 1/64"	(8.3)	11.0	(5.0)
B2302-1 1/2	1 1/2"	(40)	11 Ga.	(3.0)	1"	(25.4)	.380	(9.6)	19.2	(8.7)
B2302-2	2"	(50)	11 Ga.	(3.0)	1 1/4"	(31.7)	.389	(9.9)	28.8	(13.0)
B2302-2 1/2	2 1/2"	(65)	7 Ga.	(4.5)	1 1/4"	(31.7)	.665	(16.9)	55.2	(25.0)
B2302-3	3"	(80)	7 Ga.	(4.5)	1 1/4"	(31.7)	.650	(16.5)	68.0	(30.8)
B2302-3 1/2	3 1/2"	(90)	1/4"	(6.3)	1 1/4"	(31.7)	.622	(15.8)	96.0	(43.5)
B2302-4	4"	(100)	1/4"	(6.3)	1 1/4"	(31.7)	.630	(16.0)	108.0	(49.0)

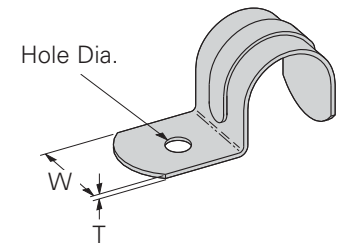

B2084 thru B2091 One Hole O.D. Tubing Clamp

- Material: 14 Gauge (1.9) ASTM A1011 33,000 PSI min. yield
- Standard finish: ZN



Part No.	O.D. Size		A		Wt./C	
	In.	mm	In.	mm	Lbs.	kg
B2084	1/4"	(6.3)	7/8"	(22.2)	4.0	(1.8)
B2085	5/16"	(7.9)	29/32"	(23.0)	4.2	(1.9)
B2086	3/8"	(9.5)	31/32"	(24.6)	5.2	(2.3)
B2087	1/2"	(12.7)	1 1/16"	(25.9)	5.8	(2.6)
B2088	5/8"	(15.9)	1 3/32"	(27.8)	7.1	(3.2)
B2089	3/4"	(19.0)	1 5/32"	(29.1)	7.7	(3.5)
B2090	7/8"	(22.2)	1 7/32"	(30.7)	8.7	(3.9)
B2091	1"	(25.4)	1 9/32"	(32.2)	10.0	(4.5)

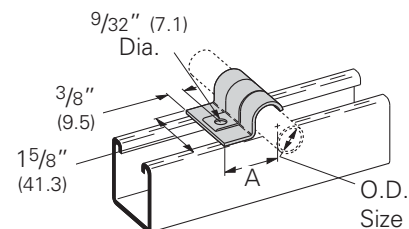

4Dimension compatible fitting

Reference page 168 for general fitting and standard finish specifications.

Pipe Clamps

BL1400 Series Conduit Hanger

- Safety Factor of 3
- Unless noted all sizes fit both rigid (R) and thinwall (EMT) conduit
- Hardware included
- Standard finishes: ZN, SS4

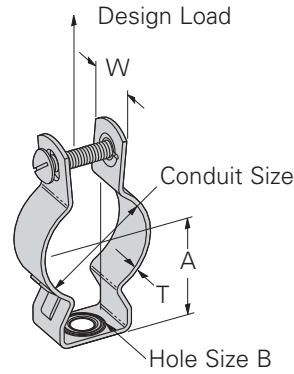

Part No	Conduit Size	A		B		T		W		Design Load		Wt./C	
		In.	mm	In.	mm	In.	mm	In.	mm	Lbs.	kN	Lbs.	kg
BL1400	1/2" EMT & Rigid	29/32"	(23.0)	9/32"	(7.1)	16 Ga.	(1.5)	3/4"	(19.0)	590	(2.62)	6	(2.7)
BL1410	3/4" EMT & Rigid	31/32"	(24.6)	9/32"	(7.1)	16 Ga.	(1.5)	3/4"	(19.0)	590	(2.62)	7	(3.2)
BL1420	1" EMT & Rigid	1 1/4"	(31.7)	9/32"	(7.1)	16 Ga.	(1.5)	3/4"	(19.0)	590	(2.62)	8	(3.6)
BL1425	1 1/4" EMT	1 1/4"	(31.7)	9/32"	(7.1)	18 Ga.	(1.2)	7/8"	(22.2)	590	(2.62)	10	(4.5)
BL1430	1 1/4" Rigid, 1 1/2" EMT	1 13/32"	(35.7)	9/32"	(8.7)	18 Ga.	(1.2)	7/8"	(22.2)	590	(2.62)	10	(4.5)
BL1440	1 1/2" Rigid	1 5/8"	(41.3)	1 1/32"	(8.7)	16 Ga.	(1.5)	1"	(25.4)	755	(3.36)	17	(7.7)
BL1450	2" EMT & Rigid	2 1/16"	(47.6)	1 1/32"	(8.7)	16 Ga.	(1.5)	1 1/4"	(31.7)	755	(3.36)	25	(11.3)
BL1460	2 1/2" EMT & Rigid	2 1/16"	(52.4)	1 1/32"	(8.7)	16 Ga.	(1.5)	1 1/4"	(31.7)	755	(3.36)	26	(11.8)
BL1470	3" EMT & Rigid	2 1/2"	(63.5)	1 1/32"	(8.7)	16 Ga.	(1.5)	1 1/4"	(31.7)	820	(3.65)	33	(14.9)
BL1480	3 1/2" EMT & Rigid	2 3/4"	(69.8)	1 1/32"	(8.7)	16 Ga.	(1.5)	1 1/4"	(31.7)	850	(3.78)	36	(16.3)
BL1490	4" EMT & Rigid	3 1/2"	(88.9)	1 1/32"	(8.7)	16 Ga.	(1.5)	1 1/4"	(31.7)	1410	(6.27)	40	(18.1)

B3373 Series Riser Clamp

- Safety Factor of 3.5
- B3373-3/4 thru B3373-8 are UL Listed
- B3373-3/4 thru B3373-6 are FM Approved
- Includes hex head cap screws and hex nuts
- Standard finishes: ZN, PLN

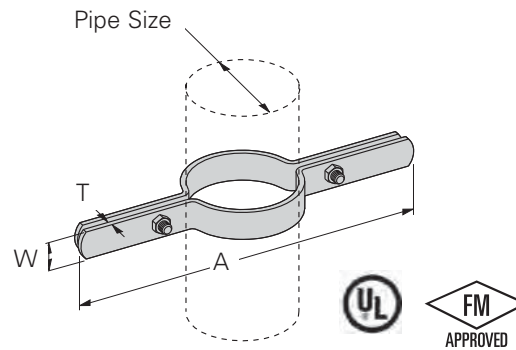

Part No.	Pipe Size		A		Design Load		Wt./C	
	In.	mm	In.	mm	Lbs.	kN	Lbs.	kg
B3373-1/2	1/2"	(15)	9"	(228.6)	255	(1.13)	101	(45.9)
B3373-3/4	3/4"	(20)	9 1/4"	(234.9)	255	(1.13)	105	(47.7)
B3373-1	1"	(25)	9 9/16"	(242.9)	255	(1.13)	109	(49.4)
B3373-1 1/4	1 1/4"	(32)	10"	(254.0)	255	(1.13)	112	(50.9)
B3373-1 1/2	1 1/2"	(32)	10 1/4"	(260.3)	255	(1.13)	113	(51.1)
B3373-2	2"	(40)	10 3/4"	(273.0)	255	(1.13)	165	(75.0)
B3373-2 1/2	2 1/2"	(50)	11 1/4"	(285.7)	390	(1.73)	180	(81.6)
B3373-3	3"	(65)	11 15/16"	(303.2)	530	(2.36)	195	(88.4)
B3373-3 1/2	3 1/2"	(80)	12 3/8"	(314.3)	670	(2.98)	217	(98.5)
B3373-4	4"	(90)	12 7/8"	(327.0)	810	(3.60)	228	(103.5)
B3373-5	5"	(100)	14"	(355.6)	1160	(5.16)	480	(217.7)
B3373-6	6"	(100)	15 3/16"	(385.8)	1570	(6.98)	526	(238.6)
B3373-8	8"	(100)	17 3/4"	(450.8)	2500	(11.12)	957	(434.1)

Reference page 168 for general fitting and standard finish specifications.

B3690 Series Adjustable J Hanger

- Safety Factor of 5
- Material:
 - 12 Ga. (2.6) ASTM A1011 33,000 PSI min. yield
 - 11 Ga. (3.0) ASTM A1011 HSLA Gr. 50 Class 1
 - 7 Ga. (4.5) ASTM A1011 33,000 PSI min. yield and 1/4" (6.3) ASTM A1018 33,000 PSI min. yield
- Standard finish: ZN

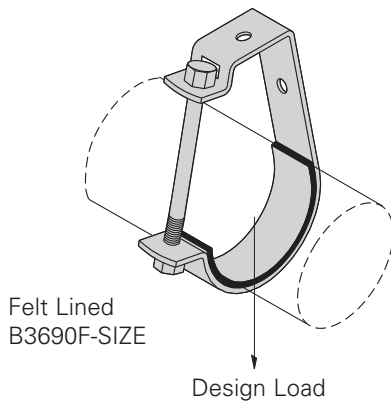

'E' Diameter. Is
For Wall Mounting

Bolt Size 'F' and
Hex Nut Included

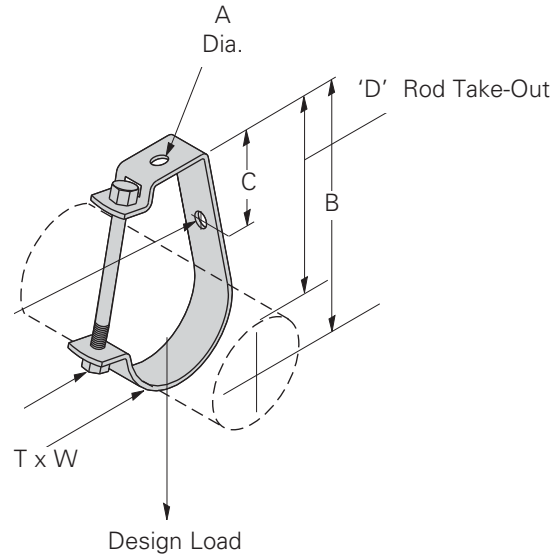

Part No.	Pipe or Conduit Size		A		B		C		D		E	
	In.	mm	In.	mm	In.	mm	In.	mm	In.	mm	In.	mm
B3690-1/2	1/2"	(15)	13/32"	(10.3)	23/32"	(53.2)	1"	(25.4)	1 11/16"	(42.5)	13/32"	(10.3)
B3690-3/4	3/4"	(20)	13/32"	(10.3)	2 11/32"	(59.5)	1"	(25.4)	1 13/16"	(46.2)	13/32"	(10.3)
B3690-1	1"	(25)	13/32"	(10.3)	2 19/32"	(65.9)	1"	(25.4)	1 15/16"	(49.2)	13/32"	(10.3)
B3690-1 1/4	1 1/4"	(32)	13/32"	(10.3)	2 13/16"	(71.4)	1"	(25.4)	2"	(50.4)	13/32"	(10.3)
B3690-1 1/2	1 1/2"	(40)	13/32"	(10.3)	3 1/16"	(77.8)	1"	(25.4)	2 1/8"	(53.7)	13/32"	(10.3)
B3690-2	2"	(50)	13/32"	(10.3)	3 1/2"	(88.9)	1"	(25.4)	2 5/16"	(58.7)	13/32"	(10.3)
B3690-2 1/2	2 1/2"	(65)	9/16"	(14.3)	4 7/16"	(112.7)	1"	(25.4)	3"	(76.2)	9/16"	(14.3)
B3690-3	3"	(80)	9/16"	(14.3)	4 7/8"	(123.8)	1"	(25.4)	3 1/8"	(79.4)	9/16"	(14.3)
B3690-3 1/2	3 1/2"	(90)	9/16"	(14.3)	5 3/16"	(131.8)	1"	(25.4)	3 3/16"	(81.0)	9/16"	(14.3)
B3690-4	4"	(100)	1 1/16"	(17.5)	6 1/8"	(155.6)	1 1/4"	(31.8)	3 7/8"	(98.4)	9/16"	(14.3)
B3690-5	5"	(125)	1 1/16"	(17.5)	6 3/4"	(171.4)	1 1/2"	(38.1)	4"	(100.8)	9/16"	(14.3)
B3690-6	6"	(150)	1 3/16"	(20.6)	7 3/4"	(196.8)	1 3/16"	(30.2)	4 7/16"	(112.7)	9/16"	(14.3)
B3690-8	8"	(200)	1 3/16"	(20.6)	9 1/4"	(235.0)	1"	(25.4)	4 15/16"	(125.4)	9/16"	(14.3)

Part No.	F Bolt Size	T		W		Design Load		Wt./C	
		In.	mm	In.	mm	Lbs.	kN	Lbs.	kg
B3690-1/2	1/4"-20 x 2 1/4"	12 Ga.	(2.6)	3/4"	(19.0)	400	(1.78)	20	(9.1)
B3690-3/4	1/4"-20 x 2 1/2"	12 Ga.	(2.6)	3/4"	(19.0)	400	(1.78)	23	(10.4)
B3690-1	1/4"-20 x 2 3/4"	12 Ga.	(2.6)	3/4"	(19.0)	400	(1.78)	24	(10.9)
B3690-1 1/4	1/4"-20 x 3"	12 Ga.	(2.6)	3/4"	(19.0)	400	(1.78)	27	(12.2)
B3690-1 1/2	1/4"-20 x 3 1/4"	12 Ga.	(2.6)	3/4"	(19.0)	400	(1.78)	29	(13.1)
B3690-2	1/4"-20 x 3 1/2"	12 Ga.	(2.6)	3/4"	(19.0)	400	(1.78)	32	(14.5)
B3690-2 1/2	3/8"-16 x 4 1/2"	11 Ga.	(3.0)	1 1/4"	(31.7)	800	(3.56)	71	(32.2)
B3690-3	3/8"-16 x 5"	11 Ga.	(3.0)	1 1/4"	(31.7)	800	(3.56)	77	(34.9)
B3690-3 1/2	3/8"-16 x 5 1/2"	11 Ga.	(3.0)	1 1/4"	(31.7)	800	(3.56)	84	(38.1)
B3690-4	3/8"-16 x 6 1/2"	7 Ga.	(4.5)	1 1/4"	(31.7)	800	(3.56)	139	(63.0)
B3690-5	3/8"-16 x 7 1/2"	7 Ga.	(4.5)	1 1/4"	(31.7)	800	(3.56)	166	(75.3)
B3690-6	3/8"-16 x 8 1/2"	1/4"	(6.3)	1 1/4"	(31.7)	1000	(4.45)	226	(102.5)
B3690-8	3/8"-16 x 10 1/2"	1/4"	(6.3)	1 1/2"	(38.1)	1200	(5.34)	332	(150.6)

Reference page 168 for general fitting and standard finish specifications.

Pipe Hangers

**Fig. 4B Series (Formerly B386 Series)
Suspension Rod Pipe Strap**

- Safety Factor of 3
- Includes hex head cap screws and hex nuts
- Standard finishes: ZN, GRN

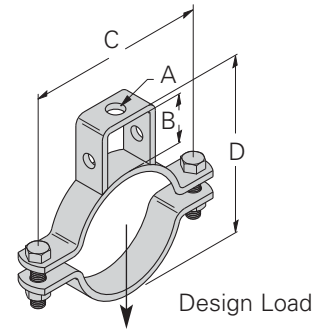

Part No.	Pipe Size		Rod Size		B		C		D		Bolt Size	Design Load		Wt./C	
	in.	mm	A		in.	mm	in.	mm	in.	mm		Lbs.	kN	Lbs.	kg
4B-3/4	3/4"	(20)	3/8"-16		1"	(25.4)	27/8"	(73.0)	25/8"	(66.7)	5/16"-18	330	(1.47)	56	(3.6)
4B-1	1"	(25)	3/8"-16		1"	(25.4)	31/4"	(82.5)	215/16"	(74.6)	5/16"-18	330	(1.47)	60	(3.6)
4B-11/4	11/4"	(32)	3/8"-16		1"	(25.4)	39/16"	(90.6)	31/4"	(82.5)	5/16"-18	330	(1.47)	74	(4.5)
4B-11/2	11/2"	(40)	3/8"-16		1"	(25.4)	313/16"	(96.8)	37/16"	(87.3)	5/16"-18	330	(1.47)	79	(5.0)
4B-2	2"	(50)	3/8"-16		11/2"	(38.1)	51/8"	(130.2)	45/8"	(117.5)	5/16"-18	440	(1.78)	156	(5.0)
4B-21/2	21/2"	(65)	1/2"-13		13/4"	(44.4)	55/8"	(142.9)	53/8"	(136.5)	3/8"-16	440	(1.78)	176	(5.4)
4B-3	3"	(80)	1/2"-13		17/8"	(47.6)	63/4"	(171.4)	61/8"	(155.5)	3/8"-16	660	(2.93)	198	(6.3)
4B-31/2	31/2"	(90)	1/2"-13		2"	(50.8)	71/4"	(184.1)	63/4"	(171.4)	3/8"-16	660	(2.93)	219	(7.2)
4B-4	4"	(100)	5/8"-11		2"	(50.8)	85/8"	(219.1)	71/4"	(184.1)	21/2"-13	800	(3.56)	288	(8.1)
4B-5	5"	(125)	5/8"-11		2"	(50.8)	97/8"	(250.8)	85/16"	(211.1)	5/8"-11	980	(4.36)	390	(8.1)
4B-6	6"	(150)	3/4"-10		21/8"	(54.0)	1015/16"	(277.8)	91/2"	(241.3)	5/8"-11	980	(4.36)	448	(8.1)
4B-8	8"	(200)	7/8"-9		21/8"	(54.0)	137/16"	(341.2)	111/2"	(292.1)	3/4"-10	1200	(5.34)	691	(8.1)

**B394 Series
Pipe Strap**

- Safety Factor of 3
- Includes:
 - 1 Pair pipe clamps with hex head cap screws and hex nuts
 - 1 Hanger strap
- Standard finishes: ZN

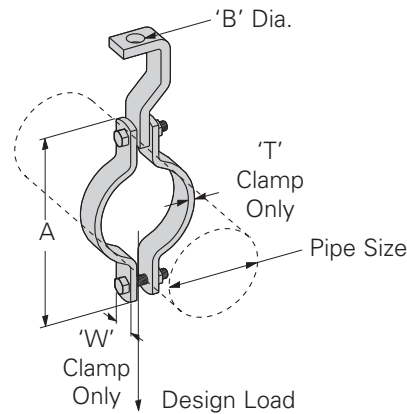

Part No.	Pipe Size		A		B		T		W		Design Load		Wt./C	
	in.	mm	in.	mm	in.	mm	in.	mm	in.	mm	Lbs.	kN	Lbs.	kg
B394-3/4	3/4"	(20)	35/16"	(84.1)	7/16"	(11.1)	1/8"	(3.2)	1"	(25.4)	500	(2.22)	71	(32.2)
B394-1	1"	(25)	33/4"	(95.2)	7/16"	(11.1)	1/8"	(3.2)	1"	(25.4)	500	(2.22)	76	(34.5)
B394-11/4	11/4"	(32)	4"	(101.6)	7/16"	(11.1)	1/8"	(3.2)	1"	(25.4)	500	(2.22)	77	(34.9)
B394-11/2	11/2"	(40)	45/16"	(109.5)	7/16"	(11.1)	1/8"	(3.2)	1"	(25.4)	800	(3.56)	79	(35.8)
B394-2	2"	(50)	51/2"	(139.7)	7/16"	(11.1)	1/4"	(6.3)	1"	(25.4)	1040	(4.62)	166	(75.3)
B394-21/2	21/2"	(65)	63/8"	(161.9)	9/16"	(14.3)	1/4"	(6.3)	1"	(25.4)	1040	(4.62)	179	(81.2)
B394-3	3"	(80)	7"	(177.8)	9/16"	(14.3)	1/4"	(6.3)	1"	(25.4)	1040	(4.62)	190	(86.2)
B394-31/2	31/2"	(90)	79/16"	(192.1)	9/16"	(14.3)	1/4"	(6.3)	1"	(25.4)	1040	(4.62)	203	(92.1)
B394-4	4"	(100)	85/8"	(219.1)	11/16"	(17.4)	1/4"	(6.3)	11/4"	(31.7)	1040	(4.62)	320	(145.1)
B394-5	5"	(125)	93/4"	(247.6)	11/16"	(17.4)	1/4"	(6.3)	11/4"	(31.7)	1040	(4.62)	353	(160.1)
B394-6	6"	(150)	115/8"	(295.3)	13/16"	(20.6)	3/8"	(9.5)	11/2"	(38.1)	1615	(7.18)	637	(288.9)
B394-8	8"	(200)	137/8"	(352.4)	13/16"	(20.6)	3/8"	(9.5)	11/2"	(38.1)	1615	(7.18)	837	(379.6)

Reference page 168 for general fitting and standard finish specifications.

B591 Series Pipe Bracket Saddle and Clamp

- Safety Factor of 3
- Inside brace not required on B591-2 and B591-2 1/2
- Includes:
 - 1 pc. Saddle bottom
 - 1 pc. Saddle top (clamp)
 - 2 pcs. Hex head cap screws
 - 2 pcs. Hex nuts
- Standard finish: ZN

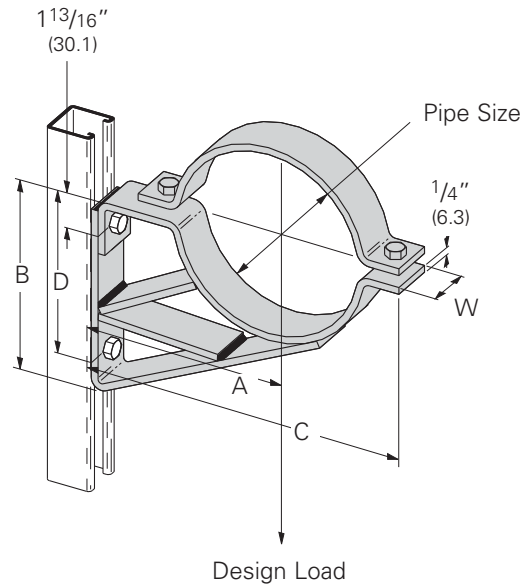

Part No.	Pipe Size		A		B		C		D		W		Design Load		Wt./C	
	In.	mm	In.	mm	In.	mm	In.	mm	In.	mm	In.	mm	Lbs.	kN	Lbs.	kg
B591-2	2"	(50)	4 1/2"	(114.3)	4 1/2"	(114.3)	7 3/16"	(182.6)	3 1/16"	(77.8)	1 5/8"	(41.3)	1235	(5.53)	290	(131.5)
B591-2 1/2	2 1/2"	(65)	5"	(127.0)	5"	(127.0)	7 15/16"	(201.6)	3 9/16"	(90.5)	1 5/8"	(41.3)	1180	(5.29)	330	(149.7)
B591-3	3"	(80)	5 1/2"	(139.7)	5 3/4"	(146.0)	8 3/4"	(222.2)	3 13/16"	(96.8)	1 5/8"	(41.3)	1125	(5.04)	439	(199.1)
B591-3 1/2	3 1/2"	(90)	6"	(152.4)	6 3/4"	(171.4)	9 1/2"	(241.3)	4 9/16"	(115.9)	1 5/8"	(41.3)	1070	(4.79)	490	(222.2)
B591-4	4"	(100)	6 1/2"	(165.1)	6 3/4"	(171.4)	10 1/4"	(260.3)	6 1/16"	(128.6)	1 5/8"	(41.3)	1015	(4.55)	545	(247.2)
B591-5	5"	(125)	7 1/2"	(190.5)	8"	(203.2)	12 1/8"	(308.0)	6 1/16"	(154.0)	1 5/8"	(41.3)	960	(4.30)	666	(302.1)
B591-6	6"	(150)	8"	(203.2)	8 3/4"	(222.2)	13 3/16"	(335.0)	6 13/16"	(173.0)	1 5/8"	(41.3)	905	(4.05)	724	(328.4)
B591-8	8"	(200)	9"	(228.6)	10 1/2"	(266.7)	15 9/16"	(395.3)	8 9/16"	(217.5)	2"	(50.8)	850	(3.81)	1087	(493.0)

4Dimension compatible fitting

Reference page 168 for general fitting and standard finish specifications.

Pipe Block

B356

Pipe Block - 2" (50) to 8" (200) Pipe

- Required hardware not included:
 - 1 pc. $\frac{3}{8}$ "-16 x 1" Hex head cap screw
 - 1 pc. $\frac{3}{8}$ "-16 Channel nut
- Material: $\frac{1}{4}$ " (6.3) thick $1\frac{5}{8}$ " (41.3) wide
ASTM A1018 33,000 PSI min. yield
- Standard finish: ZN
- Wt./C 42 Lbs. (19.0 kg) Per pair

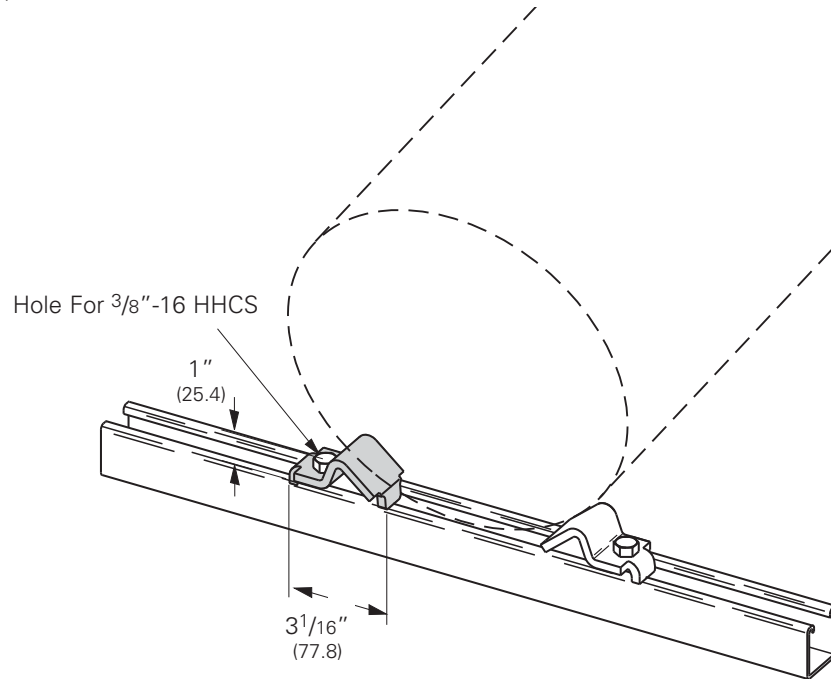

 4Dimension compatible fitting

Reference page 168 for general fitting and standard finish specifications.

B218

Pipe Rollers - 1/2" (15) to 8" (200) Pipe

- Design Load 500 Lbs. (2.22 kN)
- Safety Factor of 5
- When used with B3160 thru B3165 Saddles (see Pipe Hanger Catalog)
- Malleable iron rollers
- Sold in pairs
- Required hardware not included:
2 pcs. 1/2"-13 x 1 1/4" Hex head cap screws
2 pcs. 1/2"-13 Channel nuts
- Standard finish: ZN
- Wt./C 256 Lbs. (116.1 kg) Per pair

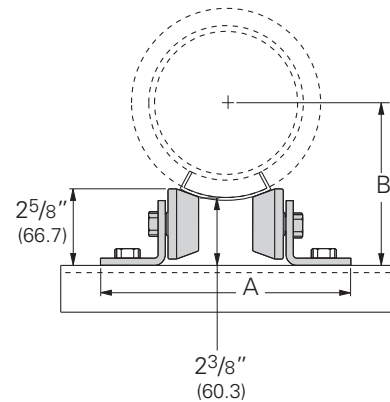
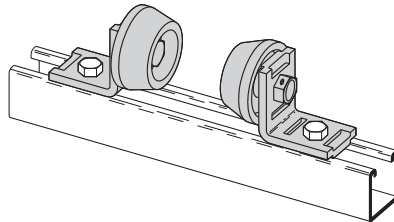

Reference Chart - A Dimension

Pipe Size	Insulation Thickness in. (mm)						
	0" (0.0)	1" (25.4)	1 1/2" (38.1)	2" (50.8)	2 1/2" (63.5)	3" (76.2)	4" (101.6)
1/2" (15)	7 1/4" (184.1)	- -	- -	- -	- -	- -	- -
3/4" (20)	7 1/4" (184.1)	7 1/4" (184.1)	7 5/8" (193.7)	8" (203.2)	- -	- -	- -
1" (25)	7 1/4" (184.1)	7 1/4" (184.1)	7 5/8" (193.7)	8 1/4" (209.5)	- -	- -	- -
1 1/4" (32)	7 1/4" (184.1)	7 1/4" (184.1)	8" (203.2)	8 1/4" (209.5)	- -	- -	- -
1 1/2" (40)	7 1/4" (184.1)	7 5/8" (193.7)	8" (203.2)	8 1/2" (215.9)	9" (228.6)	- -	- -
2" (50)	7 1/4" (184.1)	7 5/8" (193.7)	8 1/2" (215.9)	8 1/2" (215.9)	9" (228.6)	- -	- -
2 1/2" (65)	7 1/4" (184.1)	8" (203.2)	8 1/2" (215.9)	9" (228.6)	10" (254.0)	- -	- -
3" (80)	7 1/4" (184.1)	8 1/2" (215.9)	9" (228.6)	9" (228.6)	10" (254.0)	10" (254.0)	- -
3 1/2" (90)	7 1/4" (184.1)	8 1/2" (215.9)	9" (228.6)	10" (254.0)	10" (254.0)	10" (254.0)	- -
4" (100)	7 5/8" (193.7)	9" (228.6)	9" (228.6)	10" (254.0)	10" (254.0)	11" (279.4)	- -
5" (125)	8 1/2" (215.9)	9" (228.6)	10" (254.0)	10" (254.0)	11" (279.4)	11" (279.4)	12" (304.8)
6" (150)	9" (228.6)	10" (254.0)	10" (254.0)	11" (279.4)	11" (279.4)	11" (279.4)	12" (304.8)
8" (200)	10" (254.0)	11" (279.4)	11" (279.4)	11" (279.4)	12" (304.8)	- -	- -

Reference Chart - B Dimension

Pipe Size	Insulation Thickness in. (mm)						
	0" (0.0)	1" (25.4)	1 1/2" (38.1)	2" (50.8)	2 1/2" (63.5)	3" (76.2)	4" (101.6)
1/2" (15)	2 11/16" (68.3)	- -	- -	- -	- -	- -	- -
3/4" (20)	2 13/16" (71.4)	3 7/8" (98.4)	4 3/8" (111.1)	4 7/8" (123.8)	- -	- -	- -
1" (25)	2 15/16" (74.6)	4 3/16" (106.4)	4 11/16" (119.1)	5 1/16" (128.6)	- -	- -	- -
1 1/4" (32)	3 1/8" (79.4)	4 3/16" (106.4)	4 5/8" (117.5)	5 1/8" (130.2)	- -	- -	- -
1 1/2" (40)	3 1/4" (82.5)	4 3/8" (111.1)	4 7/8" (123.8)	5 5/16" (134.9)	5 3/4" (146.0)	- -	- -
2" (50)	3 9/16" (90.5)	4 11/16" (119.1)	5 1/16" (128.6)	5 5/8" (142.9)	6 1/16" (154.0)	- -	- -
2 1/2" (65)	3 13/16" (96.8)	4 7/8" (123.8)	5 5/16" (134.9)	6" (152.4)	6 3/8" (161.9)	- -	- -
3" (80)	4 1/8" (104.8)	5 1/16" (128.6)	5 9/16" (141.3)	6 1/8" (155.6)	6 7/16" (163.5)	7" (177.8)	- -
3 1/2" (90)	4 3/8" (111.1)	5 5/16" (134.9)	5 13/16" (147.6)	6 1/4" (158.7)	6 11/16" (169.9)	7 1/4" (184.1)	- -
4" (100)	4 5/8" (117.5)	5 9/16" (141.3)	6 1/16" (154.0)	6 7/16" (163.5)	6 15/16" (176.2)	7 3/8" (187.3)	- -
5" (125)	5" (127.0)	6 1/16" (154.0)	6 7/16" (163.5)	7" (177.8)	7 3/8" (187.3)	7 7/8" (200.0)	8 13/16" (223.8)
6" (150)	5 1/2" (139.7)	6 7/16" (163.5)	6 15/16" (176.2)	7 3/8" (187.3)	7 15/16" (201.6)	8 1/2" (215.9)	9 1/2" (241.3)
8" (200)	6 15/16" (160.3)	7 3/8" (187.3)	7 15/16" (201.6)	8 7/16" (214.3)	8 15/16" (227.0)	- -	- -



4Dimension compatible fitting

Reference page 168 for general fitting and standard finish specifications.

Pipe Rollers

B219

Pipe Roller Series - 3/4" (20) to 12" (300) Pipe

- Design Load 750 Lbs. (3.33 kN)
- Safety Factor of 5
- Requires field assembly
- When used with B3160 thru B3165 Saddles (see Pipe Hanger Catalog)
- Malleable iron rollers
- Sold in pairs
- Required hardware not included:
 - 2 pcs. 1/2"-13 x 1 1/4" Hex head cap screws
 - 2 pcs. 1/2"-13 Channel nuts
- Reference sizing chart on page 193
- Standard finish: ZN

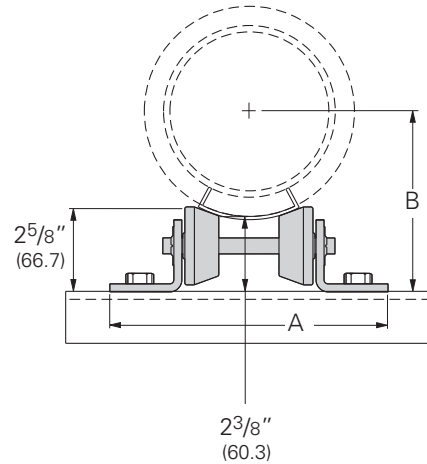
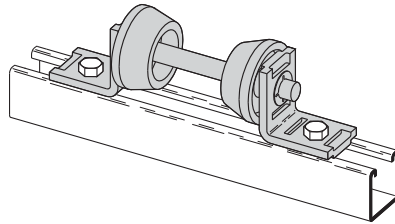

Reference Chart - A Dimension

Part No.	A		Wt./C PR	
	In.	mm	Lbs.	kg
B219	7 1/4"	(184.1)	253	(114.7)
B219-1	8"	(203.2)	258	(117.0)
B219-2	9"	(228.6)	263	(119.3)
B219-3	10"	(254.0)	269	(122.0)
B219-4	10 7/8"	(276.2)	274	(124.8)
B219-5	11 5/8"	(295.3)	279	(126.5)

Reference Chart - B Dimension

Pipe Size	Insulation Thickness in. (mm)						
	0" (0.0)	1" (25.4)	1 1/2" (38.1)	2" (50.8)	2 1/2" (63.5)	3" (76.2)	4" (101.6)
1/2" (15)	2 1/16" (68.3)	-	-	-	-	-	-
3/4" (20)	2 3/16" (71.4)	3 7/8" (98.4)	4 1/2" (114.3)	4 7/8" (123.8)	-	-	-
1" (25)	2 5/16" (74.6)	4 3/16" (106.4)	4 5/8" (117.5)	5 1/16" (128.6)	-	-	-
1 1/4" (32)	3 1/8" (79.4)	4 3/16" (106.4)	4 5/8" (117.5)	5 1/8" (130.2)	-	-	-
1 1/2" (40)	3 1/4" (82.5)	4 7/16" (112.7)	4 7/8" (123.8)	5 1/4" (133.3)	5 3/4" (146.0)	-	-
2" (50)	3 9/16" (90.5)	4 5/8" (117.5)	5 3/16" (131.8)	5 1/2" (139.7)	6 1/16" (154.0)	-	-
2 1/2" (65)	3 3/4" (95.2)	4 7/8" (123.8)	5 1/4" (133.3)	6" (152.4)	6 3/8" (161.9)	-	-
3" (80)	4 1/8" (104.8)	5 1/8" (130.2)	5 9/16" (141.3)	6 1/16" (154.0)	6 7/16" (163.5)	6 15/16" (176.2)	-
3 1/2" (90)	4 1/4" (107.9)	5 1/4" (133.3)	5 13/16" (147.6)	6 1/4" (158.7)	6 11/16" (169.9)	7 1/16" (179.4)	-
4" (100)	4 9/16" (115.9)	5 1/2" (139.7)	6 1/16" (154.0)	6 7/16" (163.5)	6 15/16" (176.2)	7 3/8" (187.3)	-
5" (125)	5 1/16" (128.6)	6 1/16" (154.0)	6 7/16" (163.5)	7" (177.8)	7 3/8" (187.3)	7 7/8" (200.0)	8 15/16" (227.0)
6" (150)	5 7/16" (138.1)	6 7/16" (163.5)	6 15/16" (176.2)	7 3/8" (187.3)	7 7/8" (200.0)	8 15/16" (211.1)	9 9/16" (242.9)
8" (200)	6 3/8" (161.9)	7 7/16" (188.9)	7 15/16" (201.6)	8 3/8" (212.7)	9" (228.6)	-	-
10" (250)	7 5/16" (185.7)	8 3/16" (208.0)	-	-	-	-	-
12" (300)	8 1/4" (209.5)	-	-	-	-	-	-

Reference B219 sizing chart on page 193



4Dimension compatible fitting

Reference page 168 for general fitting and standard finish specifications.

B219 Sizing Chart

Pipe Size	Insulation Thickness in. (mm)						
	0" (0.0)	1" (25.4)	1 1/2" (38.1)	2" (50.8)	2 1/2" (63.5)	3" (76.2)	4" (101.6)
1/2" (15)	B219	–	–	–	–	–	–
3/4" (20)	B219	B219	B219	B219-1	–	–	–
1" (25)	B219	B219	B219-1	B219-1	–	–	–
1 1/4" (32)	B219	B219	B219-1	B219-1	–	–	–
1 1/2" (40)	B219	B219	B219-1	B219-2	B219-2	–	–
2" (50)	B219	B219-1	B219-1	B219-2	B219-2	–	–
2 1/2" (65)	B219	B219-1	B219-2	B219-2	B219-3	–	–
3" (80)	B219	B219-1	B219-2	B219-2	B219-3	B219-3	–
3 1/2" (90)	B219-1	B219-2	B219-2	B219-3	B219-3	B219-4	–
4" (100)	B219-1	B219-2	B219-2	B219-3	B219-3	B219-4	–
5" (125)	B219-1	B219-2	B219-3	B219-3	B219-4	B219-4	B219-5
6" (150)	B219-2	B219-3	B219-3	B219-4	B219-4	B219-5	B219-5
8" (200)	B219-3	B219-4	B219-4	B219-5	B219-5	–	–
10" (250)	B219-4	B219-5	–	–	–	–	–
12" (300)	B219-5	–	–	–	–	–	–

Reference page 168 for general fitting and standard finish specifications.

Pipe Rollers

B379

Pipe Rollers - 6" (150) to 18" (450) Pipe

- Design Load 1500 Lbs. (6.67 kN)
- Safety Factor of 5
- Requires field assembly
- When used with B3160 thru B3165 Saddles (see Pipe Hanger Catalog)
- Malleable iron rollers
- Sold in pairs
- Required hardware not included:
2 pcs. 1/2"-13 x 1 1/4" Hex head cap screws
2 pcs. 1/2"-13 Channel nuts
- Standard finish: ZN
- Wt./C 889 Lbs. (403.2 kg)

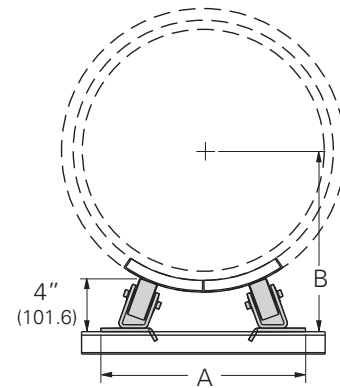
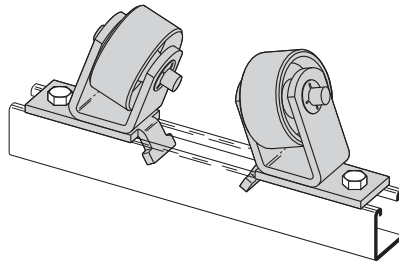

Reference Chart - A Dimension

Pipe Size	Insulation Thickness in. (mm)						
	0" (0.0)	1" (25.4)	1 1/2" (38.1)	2" (50.8)	2 1/2" (63.5)	3" (76.2)	4" (101.6)
6" (150)	9 9/16" (242.9)	10 3/16" (258.8)	10 5/8" (269.9)	11" (279.4)	11 3/8" (288.9)	11 3/4" (298.4)	12 1/2" (317.5)
8" (200)	10 1/4" (260.3)	11 1/16" (281.0)	11 3/8" (288.9)	11 3/4" (298.4)	12 3/16" (309.6)	12 1/2" (317.5)	13 1/4" (336.5)
10" (250)	11" (279.4)	11 3/4" (298.4)	12 1/8" (308.0)	12 1/2" (317.5)	12 13/16" (325.4)	13 1/8" (333.4)	13 7/8" (352.4)
12" (300)	11 11/16" (296.9)	12 9/16" (319.1)	12 7/8" (327.0)	13 1/4" (336.5)	13 9/16" (344.5)	13 7/8" (352.4)	14 5/8" (371.5)
14" (350)	12 1/16" (306.4)	12 7/8" (327.0)	13 3/16" (335.0)	13 9/16" (344.5)	13 7/8" (352.4)	14 1/4" (361.9)	14 7/8" (377.8)
16" (400)	12 3/4" (323.8)	13 1/2" (342.9)	13 7/8" (352.4)	14 13/16" (360.4)	14 1/2" (368.3)	14 7/8" (377.8)	15 1/2" (393.7)
18" (450)	13 1/2" (342.9)	14 1/4" (361.9)	14 5/8" (371.5)	15" (381.0)	15 5/16" (388.9)	15 5/8" (396.9)	16 5/16" (414.3)

Reference Chart - B Dimension

Pipe Size	Insulation Thickness in. (mm)						
	0" (0.0)	1" (25.4)	1 1/2" (38.1)	2" (50.8)	2 1/2" (63.5)	3" (76.2)	4" (101.6)
6" (150)	6 7/8" (174.6)	7 7/8" (200.0)	8 3/8" (212.7)	8 7/8" (225.4)	9 3/8" (238.1)	9 7/8" (250.8)	10 15/16" (277.8)
8" (200)	7 13/16" (198.4)	8 7/8" (225.4)	9 3/8" (238.1)	9 7/8" (250.8)	10 7/16" (265.1)	10 15/16" (277.8)	11 7/8" (301.6)
10" (250)	8 13/16" (223.8)	9 7/8" (250.8)	10 7/16" (265.1)	10 15/16" (277.8)	11 3/8" (288.9)	11 7/8" (301.6)	12 13/16" (325.4)
12" (300)	9 3/4" (247.6)	10 15/16" (277.8)	11 3/8" (288.9)	11 7/8" (301.6)	12 5/16" (312.7)	12 13/16" (325.4)	13 3/4" (349.2)
14" (350)	10 5/16" (261.9)	11 3/8" (288.9)	11 7/8" (301.6)	12 5/16" (312.7)	12 13/16" (325.4)	13 1/4" (336.5)	14 1/4" (361.9)
16" (400)	11 5/16" (287.3)	12 5/16" (312.7)	12 13/16" (325.4)	13 1/4" (336.5)	13 3/4" (349.2)	14 1/4" (361.9)	15 1/8" (384.2)
18" (450)	12 1/4" (311.1)	13 1/4" (336.5)	13 3/4" (349.2)	14 3/16" (360.4)	14 11/16" (373.1)	15 1/8" (384.2)	16 1/16" (408.0)



4Dimension compatible fitting

Reference page 168 for general fitting and standard finish specifications.

B479

Pipe Rollers - 16" (400) to 30" (750) Pipe

- Design Load 2000 Lbs. (8.89 kN)
- Safety Factor of 5
- Requires field assembly
- When used with B3160 thru B3165 Saddles (see Pipe Hanger Catalog)
- Malleable iron rollers
- Sold in pieces
- Required hardware not included:
 - 4 pcs. 1/2"-13 x 1 1/4" Hex head cap screws
 - 4 pcs. 1/2"-13 Channel nuts
- Standard finish: ZN
- Wt./C 889 Lbs. (403.2 kg)

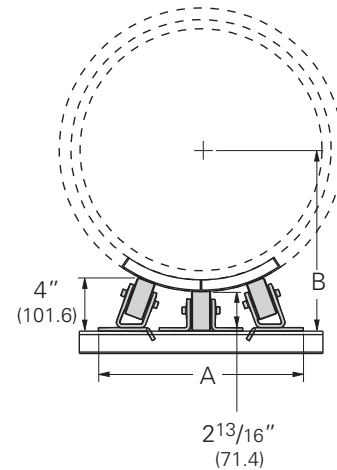
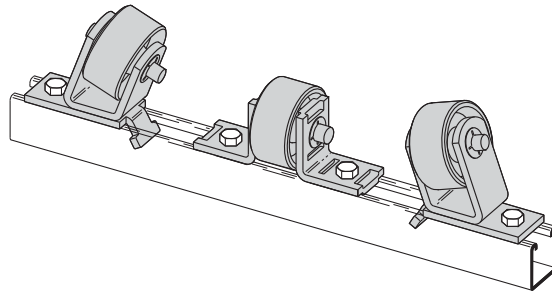

Reference Chart - A Dimension

Pipe Size	Insulation Thickness in. (mm)						
	0" (0.0)	1" (25.4)	1 1/2" (38.1)	2" (50.8)	2 1/2" (63.5)	3" (76.2)	4" (101.6)
16" (400)	15 ³ / ₁₆ " (385.8)	15 ⁵ / ₈ " (396.9)	15 ⁷ / ₈ " (403.2)	16" (406.4)	16 ¹ / ₄ " (412.7)	16 ¹ / ₂ " (419.1)	17" (431.8)
18" (450)	15 ¹ / ₂ " (393.7)	16" (406.4)	16 ³ / ₁₆ " (411.2)	16 ³ / ₈ " (415.9)	16 ⁹ / ₁₆ " (420.7)	16 ³ / ₄ " (425.4)	17 ³ / ₁₆ " (436.6)
20" (500)	16" (406.4)	16 ³ / ₈ " (415.9)	16 ⁹ / ₁₆ " (420.7)	16 ⁷ / ₈ " (428.6)	16 ¹⁵ / ₁₆ " (430.2)	17 ³ / ₁₆ " (436.6)	17 ¹ / ₂ " (444.5)
24" (600)	16 ¹³ / ₁₆ " (427.0)	17 ⁵ / ₁₆ " (439.7)	17 ¹ / ₂ " (444.5)	17 ¹ / ₂ " (444.5)	17 ¹¹ / ₁₆ " (449.3)	17 ⁷ / ₈ " (454.0)	18 ¹ / ₈ " (460.4)
30" (750)	17 ¹³ / ₁₆ " (452.4)	18 ¹ / ₄ " (463.5)	18 ³ / ₈ " (466.7)	18 ⁹ / ₁₆ " (471.5)	18 ⁷ / ₈ " (476.2)	18 ⁷ / ₈ " (479.4)	19 ¹ / ₄ " (488.9)

Reference Chart - B Dimension

Pipe Size	Insulation Thickness in. (mm)						
	0" (0.0)	1" (25.4)	1 1/2" (38.1)	2" (50.8)	2 1/2" (63.5)	3" (76.2)	4" (101.6)
16" (400)	10 ¹³ / ₁₆ " (274.6)	11 ¹⁵ / ₁₆ " (303.2)	12 ³ / ₈ " (314.3)	12 ¹⁵ / ₁₆ " (328.6)	13 ³ / ₈ " (339.7)	13 ¹⁵ / ₁₆ " (354.0)	14 ¹⁵ / ₁₆ " (379.4)
18" (450)	11 ⁷ / ₈ " (301.6)	12 ¹⁵ / ₁₆ " (328.6)	13 ⁷ / ₁₆ " (341.3)	13 ¹⁵ / ₁₆ " (354.0)	14 ⁷ / ₁₆ " (366.7)	14 ¹⁵ / ₁₆ " (379.4)	15 ¹⁵ / ₁₆ " (404.8)
20" (500)	12 ³ / ₁₆ " (325.4)	13 ¹⁵ / ₁₆ " (354.0)	14 ⁷ / ₁₆ " (366.7)	14 ⁷ / ₈ " (377.8)	15 ⁷ / ₁₆ " (392.1)	15 ⁷ / ₈ " (403.2)	16 ¹⁵ / ₁₆ " (430.2)
24" (600)	14 ¹³ / ₁₆ " (376.2)	15 ⁷ / ₈ " (403.2)	16 ³ / ₈ " (415.9)	16 ⁷ / ₈ " (428.6)	17 ³ / ₈ " (441.3)	17 ⁷ / ₈ " (454.0)	18 ⁷ / ₈ " (479.4)
30" (750)	17 ¹³ / ₁₆ " (452.4)	18 ⁷ / ₈ " (479.4)	19 ³ / ₈ " (492.1)	19 ⁷ / ₈ " (504.8)	20 ³ / ₈ " (517.5)	20 ⁵ / ₁₆ " (531.8)	21 ¹⁵ / ₁₆ " (557.2)



4Dimension compatible fitting

Reference page 168 for general fitting and standard finish specifications.