

Pipe Rollers & Roller Supports

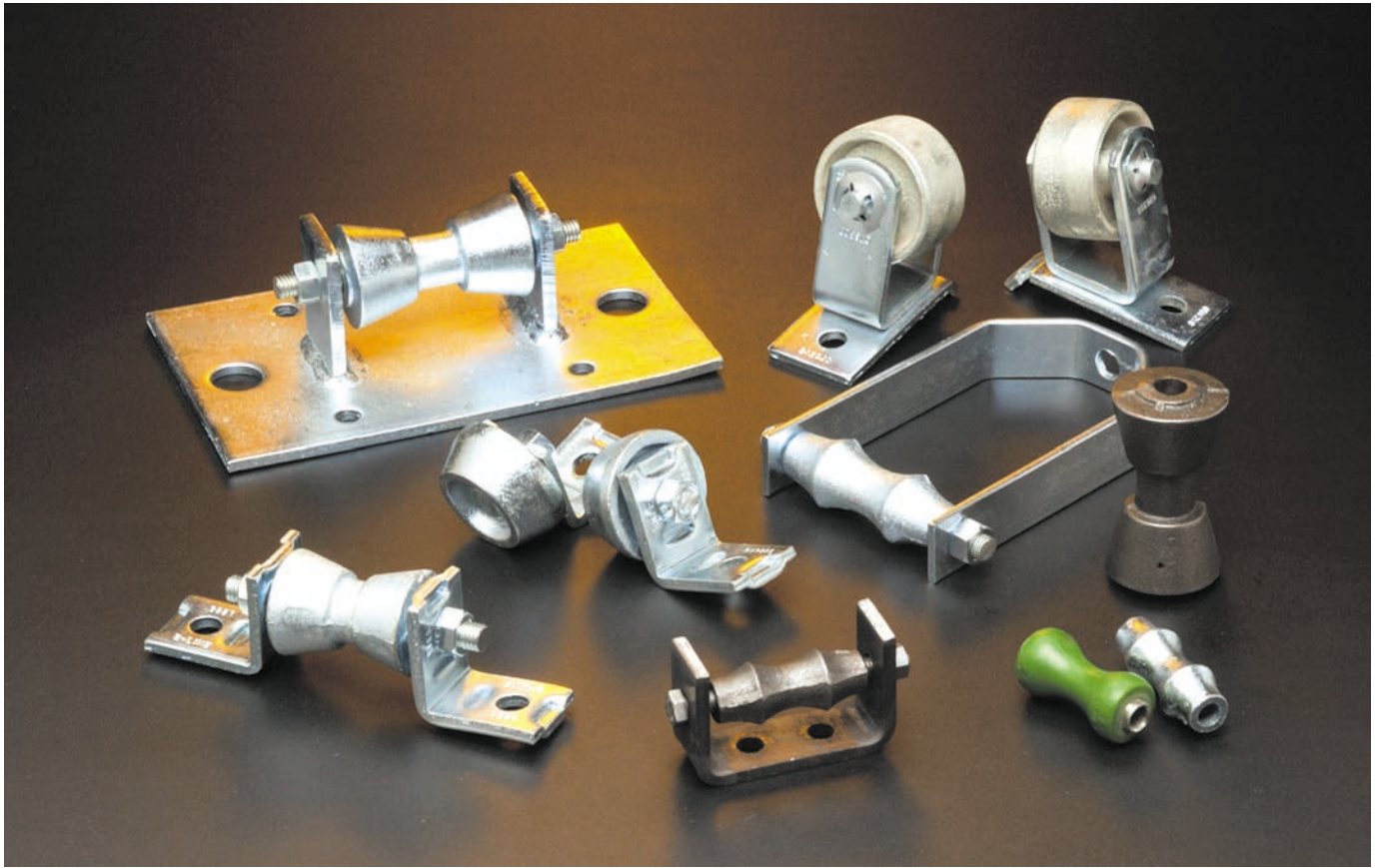

Pipe rollers and roller supports offered in this section are designed to compensate for longitudinal movement due to the expansion or contraction of both insulated or non-insulated pipe.

Materials

Carbon Steel with Cast Iron rollers are used in the manufacture of pipe roller supports. Stainless Steel and other materials are available.

Finishes

The standard finishes for mechanical supports are plain steel (oil coated) sometimes referred to as black and Electro-Galvanized Zinc (ASTM B633 SC3). Hot-Dip Galvanized After Fabrication (ASTM A123), Red Primer, Plastic Coating, DURA GREEN™ and other special coatings are available upon request.

Note: Due to the design of some products, (threads, connecting hardware, swivels, etc.) items may or may not be uniformly coated with special finishes. In some cases, the hanger itself may be coated, however, the hardware may be supplied Electro-Plated, Copper plated, or in Stainless Steel.

Approvals (as noted)

Items in this section comply with Federal Specification WW-H-171E & A-A-1192A or Manufacturers Standardization Society ANSI/MSS SP-69 SP-58.

B3110 - Adjustable Steel Yoke Pipe Roll

Size Range: 2" (65mm) thru 24" (600mm) pipe

Material: Cast iron roller and steel axle/hanger
(Non-metallic polyurethane rollers are available)

Function: For supporting pipe where movement may occur due to thermal expansion.

Approvals: Conforms to Federal Specification WW-H-171E & A-A-1192A, Type 44, 1" (25mm) thru 20" (500mm), and Manufacturers Standardization Society ANSI/MSS SP-69 & SP-58, Type 43.

Note: When pipe line is insulated, total outside diameter of pipe and covering should be used to determine size of hanger; also see B3160 to B3165 on pages 158 thru 163.

Finish: Plain. Contact customer service for alternative finishes and materials.

Order By: Part number, pipe size and finish

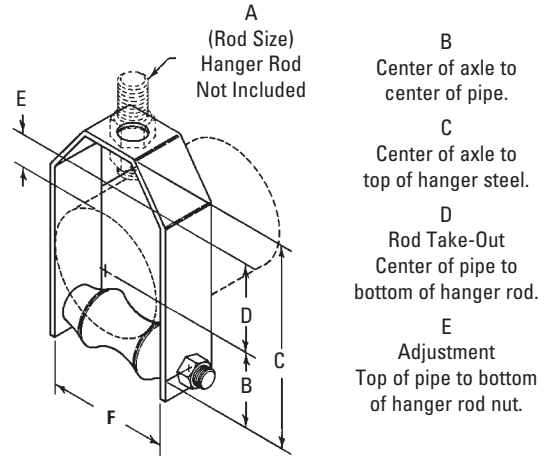

Note: Not for continuous cycling applications.

Part No.	Pipe Size		Rod Size		B		C		D		E	
	in.	(mm)	A	in.	(mm)	in.	(mm)	in.	(mm)	in.	(mm)	
B3110-2	2"	(50)	3/8"-16	1 9/16"	(39.7)	4 3/4"	(120.6)	2 3/8"	(60.3)	1 7/16"	(36.5)	
B3110-2 1/2	2 1/2"	(65)	1/2"-13	1 7/8"	(47.6)	6"	(152.4)	3 3/16"	(81.0)	2"	(50.8)	
B3110-3	3"	(80)	1/2"-13	2 3/16"	(55.6)	6 5/8"	(168.3)	3 1/2"	(88.9)	2"	(50.8)	
B3110-3 1/2	3 1/2"	(90)	1/2"-13	2 1/2"	(63.5)	7 1/4"	(184.1)	3 3/4"	(95.2)	2"	(50.8)	
B3110-4	4"	(100)	5/8"-11	2 3/4"	(69.8)	7 7/8"	(200.0)	4"	(101.6)	2"	(50.8)	
B3110-5	5"	(125)	5/8"-11	3 3/8"	(85.7)	9 3/16"	(233.4)	4 9/16"	(115.9)	2"	(50.8)	
B3110-6	6"	(150)	3/4"-10	3 15/16"	(100.0)	10 3/8"	(263.5)	5 1/16"	(128.6)	2"	(50.8)	
B3110-8	8"	(200)	3/4"-10	5 1/16"	(128.6)	12 5/8"	(320.7)	6 1/16"	(154.0)	2"	(50.8)	
B3110-10	10"	(250)	7/8"-9	6 1/4"	(158.7)	14 15/16"	(379.4)	7 3/16"	(182.6)	2 1/16"	(52.4)	
B3110-12	12"	(300)	7/8"-9	7 3/8"	(187.3)	17 3/8"	(441.3)	8 3/8"	(212.7)	2 1/4"	(57.1)	
B3110-14	14"	(350)	1"-8	8 1/4"	(209.5)	19"	(482.6)	8 3/4"	(222.2)	2 1/4"	(57.1)	
B3110-16	16"	(400)	1"-8	9 1/4"	(234.9)	20 3/4"	(527.0)	9 3/4"	(247.6)	2"	(50.8)	
B3110-18	18"	(450)	1"-8	10 3/8"	(263.5)	23 11/16"	(601.7)	11 7/16"	(290.5)	2 1/16"	(52.4)	
B3110-20	20"	(500)	1 1/4"-7	11 1/2"	(292.1)	25 7/8"	(657.2)	12 1/4"	(311.1)	2 1/2"	(63.5)	
B3110-24	24"	(600)	1 1/2"-6	13 13/16"	(350.8)	31 9/16"	(801.7)	15"	(381.0)	3 1/2"	(88.9)	

Part No.	F		Maximum O.D. Covering		Design Load		Approx. Wt./100	
	in.	(mm)	in.	(mm)	lbs.	(kN)	Lbs.	(kg)
B3110-2	2 7/8"	(73.0)	2 5/8"	(66.7)	150	(.67)	123	(55.8)
B3110-2 1/2	3 1/4"	(82.5)	3"	(76.2)	225	(1.00)	178	(80.7)
B3110-3	3 7/8"	(98.4)	3 5/8"	(92.1)	310	(1.38)	206	(93.4)
B3110-3 1/2	4 3/8"	(111.1)	4 1/8"	(104.8)	390	(1.73)	267	(121.1)
B3110-4	4 7/8"	(123.8)	4 11/16"	(119.1)	475	(2.11)	344	(156.0)
B3110-5	5 15/16"	(150.8)	5 3/4"	(146.0)	685	(3.04)	600	(272.1)
B3110-6	7"	(177.8)	6 3/4"	(171.4)	780	(3.47)	800	(362.9)
B3110-8	9"	(228.6)	8 3/4"	(222.2)	780	(3.47)	1300	(589.7)
B3110-10	11 1/8"	(282.6)	10 3/4"	(273.0)	965	(4.29)	1600	(725.7)
B3110-12	13 3/8"	(339.7)	13"	(330.2)	1200	(5.34)	2600	(1179.3)
B3110-14	14 1/2"	(368.3)	14 1/4"	(361.9)	1200	(5.34)	3400	(1542.2)
B3110-16	16 3/8"	(415.9)	16 1/8"	(409.6)	1200	(5.34)	3900	(1769.0)
B3110-18	18 3/8"	(466.7)	18 1/8"	(460.4)	1400	(6.23)	4900	(2222.6)
B3110-20	20 3/8"	(517.5)	20 1/8"	(511.2)	1600	(7.11)	6686	(3032.7)
B3110-24	24 5/8"	(625.5)	24 3/8"	(619.1)	1800	(8.00)	11630	(5275.3)



Note: If using D.I. pipe refer to page 321 for sizing. Non-metallic rollers with stainless steel yoke and hardware are available for most sizes (B3110NM-Pipe Size). Contact Eaton Engineering for more information.

All dimensions in charts and on drawings are in inches. Dimensions shown in parentheses are in millimeters unless otherwise specified.

Pipe Rollers & Roller Supports

B3114 - Pipe Roll with Sockets

Size Range: 2" (25mm) thru 30" (750mm) pipe

Material: Cast iron roller and steel axle
(Non-metallic polyurethane rollers are available)

Function: For supporting pipe where expansion may occur due to thermal movement. Double rod design provides support for greater loads.

Approvals: Conforms to Federal Specification WW-H-171E & A-A-1192A, Type 42, 2" (50mm) thru 24" (600mm), and Manufacturers Standardization Society ANSI/MSS SP-69 & SP-58, Type 41

Note: When pipe line is insulated, total outside diameter of pipe and covering should be used to determine size of hanger; also see B3160 to B3165 on pages 158 thru 163.

Finish: Plain. Contact customer service for alternative finishes and materials.

Order By: Part number, pipe size and finish

Note: Not for continuous cycling applications.

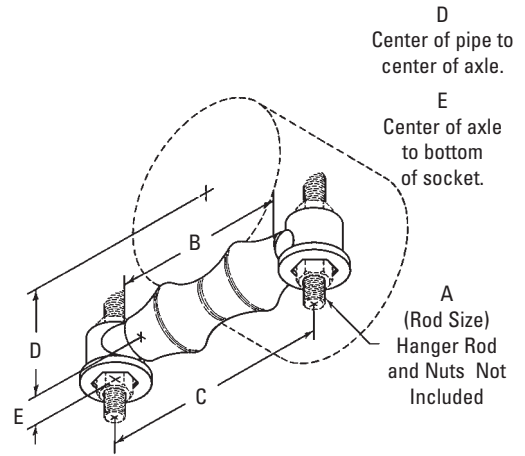

Part No.	Pipe Size		Rod Size		B		C		D	
	in.	(mm)	A	in. (mm)	in. (mm)	in. (mm)	in. (mm)	in. (mm)		
B3114-2	2"	(50)	3/8"-16	25/8" (66.7)	41/8" (104.8)	19/16" (39.7)				
B3114-2 1/2	2 1/2"	(65)	1/2"-13	31/8" (79.4)	47/8" (123.8)	17/8" (47.6)				
B3114-3	3"	(80)	1/2"-13	33/4" (95.2)	51/2" (139.7)	23/16" (55.6)				
B3114-3 1/2	3 1/2"	(90)	1/2"-13	41/4" (107.9)	61/8" (155.6)	21/2" (63.5)				
B3114-4	4"	(100)	5/8"-11	43/4" (120.6)	63/4" (171.4)	23/4" (69.8)				
B3114-5	5"	(125)	5/8"-11	513/16" (147.6)	81/16" (204.8)	33/8" (85.7)				
B3114-6	6"	(150)	3/4"-10	67/8" (174.6)	99/16" (242.9)	315/16" (100.0)				
B3114-8	8"	(200)	7/8"-9	87/8" (225.4)	1115/16" (303.2)	51/16" (128.6)				
B3114-10	10"	(250)	7/8"-9	11" (279.4)	141/16" (357.2)	61/4" (158.7)				
B3114-12	12"	(300)	7/8"-9	13" (330.2)	1513/16" (401.6)	73/8" (187.3)				
B3114-14	14"	(350)	1"-8	141/4" (361.9)	173/4" (450.8)	81/4" (209.5)				
B3114-16	16"	(400)	1"-8	161/4" (412.7)	193/4" (501.6)	91/4" (234.9)				
B3114-18	18"	(450)	1"-8	181/4" (463.5)	217/8" (555.6)	103/8" (263.5)				
B3114-20	20"	(500)	1 1/4"-7	201/4" (514.3)	241/4" (615.9)	111/2" (292.1)				
B3114-24	24"	(600)	1 1/2"-6	241/4" (615.9)	287/8" (733.4)	1313/16" (350.8)				
B3114-30	30"	(750)	1 1/2"-6	301/4" (768.3)	351/2" (901.7)	171/4" (438.1)				

Note: If using D.I. pipe refer to page 321 for sizing. Non-metallic rollers with hot-dip galvanized sockets and stainless steel hardware are available for most sizes (B3114NM-Pipe Size). Contact Eaton Engineering for more information.

Part No.	E		Max. O.D. Covering		Design Load		Approx. Wt./100	
	in.	(mm)	in.	(mm)	Lbs.	(kN)	Lbs.	(kg)
B3114-2	3/4"	(19.0)	33/4"	(82.5)	600	(2.67)	119	(54.0)
B3114-2 1/2	3/4"	(19.0)	33/4"	(95.2)	660	(2.93)	140	(63.5)
B3114-3	3/4"	(19.0)	41/2"	(114.3)	700	(3.11)	158	(71.6)
B3114-3 1/2	3/4"	(19.0)	5"	(127.0)	750	(3.33)	170	(77.1)
B3114-4	3/4"	(19.0)	57/8"	(149.2)	750	(3.33)	188	(85.3)
B3114-5	3/4"	(19.0)	7"	(177.8)	750	(3.33)	246	(111.6)
B3114-6	1 1/8"	(28.6)	81/4"	(209.5)	1070	(4.76)	504	(228.6)
B3114-8	1 1/8"	(28.6)	101/2"	(266.7)	1350	(6.00)	658	(298.4)
B3114-10	1 1/8"	(28.6)	123/4"	(323.8)	1730	(7.69)	849	(385.1)
B3114-12	1 1/8"	(28.6)	143/4"	(374.6)	2400	(10.67)	1200	(544.3)
B3114-14	1 1/2"	(38.1)	161/4"	(412.7)	3130	(13.92)	2289	(1038.3)
B3114-16	1 1/2"	(38.1)	18"	(457.2)	3970	(17.66)	2497	(1132.6)
B3114-18	1 1/2"	(38.1)	201/4"	(514.3)	4200	(18.68)	2899	(1315.0)
B3114-20	1 1/2"	(38.1)	221/2"	(571.5)	4550	(20.24)	3637	(1649.7)
B3114-24	2"	(50.8)	261/2"	(673.1)	6160	(27.40)	5664	(2569.2)
B3114-30	2"	(50.8)	321/2"	(825.5)	7290	(32.42)	9437	(4280.6)

36" (900) available upon request.

All dimensions in charts and on drawings are in inches. Dimensions shown in parentheses are in millimeters unless otherwise specified.

B3122 - Adjustable Roller Support

Size Range: 2" (25mm) thru 24" (750mm) pipe

Material: Cast iron roller and steel axle
(Non-metallic polyurethane rollers are available)

Function: Designed for suspending pipe where longitudinal movement and vertical adjustment is required.

Approvals: Conforms to Federal Specification WW-H-171E & A-A-1192A, Type 42, 2" (50mm) thru 24" (600mm), and Manufacturers Standardization Society ANSI/MSS SP-69 & SP-58, Type 41

Note: When pipe line is insulated, total outside diameter of pipe and covering should be used to determine size of hanger; also see B3160 to B3165 on pages 158 thru 163.

Finish: Plain. Contact customer service for alternative finishes and materials.

Furnished With: B3114 Roller, two support rods and eight HN Hex Nuts — not assembled.

Order By: Part number, pipe size and finish

Note: Not for continuous cycling applications.

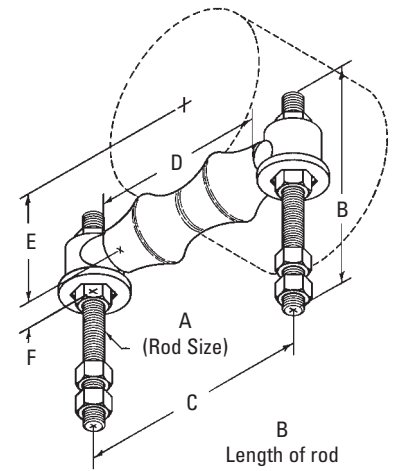

B
Length of rod

C
Center to center distance of rod.

D
Length of Roller

E
Center of axle to center of pipe.

F
Center of axle to bottom of socket.



Part No.	Pipe Size		Rod Size		B		C		D	
	in.	(mm)	A	in. (mm)	in. (mm)	in. (mm)	in. (mm)	in. (mm)		
B3122-2	2"	(50)	3/8"-16	12" (304.8)	4 1/8" (104.8)	2 5/8" (66.7)				
B3122-2 1/2	2 1/2"	(65)	1/2"-13	12" (304.8)	4 7/8" (123.8)	3 1/8" (79.4)				
B3122-3	3"	(80)	1/2"-13	12" (304.8)	5 1/2" (139.7)	3 3/4" (95.2)				
B3122-3 1/2	3 1/2"	(90)	1/2"-13	12" (304.8)	6 1/8" (155.6)	4 1/4" (107.9)				
B3122-4	4"	(100)	5/8"-11	12" (304.8)	6 3/4" (171.4)	4 3/4" (120.6)				
B3122-5	5"	(125)	5/8"-11	12" (304.8)	8 1/16" (204.8)	5 13/16" (147.6)				
B3122-6	6"	(150)	3/4"-10	12" (304.8)	9 9/16" (242.9)	6 7/8" (174.6)				
B3122-8	8"	(200)	7/8"-9	12" (304.8)	11 15/16" (303.2)	8 7/8" (225.4)				
B3122-10	10"	(250)	7/8"-9	12" (304.8)	14 1/16" (357.2)	11" (279.4)				
B3122-12	12"	(300)	7/8"-9	12" (304.8)	15 13/16" (401.6)	13" (330.2)				
B3122-14	14"	(350)	1"-8	12" (304.8)	17 3/4" (450.8)	14 1/4" (361.9)				
B3122-16	16"	(400)	1"-8	18" (457.2)	19 3/4" (501.6)	16 1/4" (412.7)				
B3122-18	18"	(450)	1"-8	18" (457.2)	21 7/8" (555.6)	18 1/4" (463.5)				
B3122-20	20"	(500)	1 1/4"-7	18" (457.2)	24 1/4" (615.9)	20 1/4" (514.3)				
B3122-24	24"	(600)	1 1/2"-6	24" (609.6)	28 7/8" (733.4)	24 1/4" (615.9)				

Part No.	E		F		Design Load		Approx. Wt./100	
	in.	(mm)	in.	(mm)	Lbs.	(kN)	Lbs.	(kg)
B3122-2	1 9/16"	(39.7)	3/4"	(19.0)	600	(2.67)	194	(88.0)
B3122-2 1/2	1 7/8"	(47.6)	3/4"	(19.0)	660	(2.93)	284	(128.8)
B3122-3	2 3/16"	(55.6)	3/4"	(19.0)	700	(3.11)	302	(137.0)
B3122-3 1/2	2 1/2"	(63.5)	3/4"	(19.0)	750	(3.33)	314	(142.4)
B3122-4	2 3/4"	(69.8)	3/4"	(19.0)	750	(3.33)	438	(198.7)
B3122-5	3 3/8"	(85.7)	3/4"	(19.0)	750	(3.33)	495	(224.5)
B3122-6	3 15/16"	(100.0)	1 1/8"	(28.6)	1070	(4.76)	867	(393.3)
B3122-8	5 1/16"	(128.6)	1 1/8"	(28.6)	1350	(6.00)	1176	(533.4)
B3122-10	6 1/4"	(158.7)	1 1/8"	(28.6)	1730	(7.69)	1368	(620.5)
B3122-12	7 3/8"	(187.3)	1 1/8"	(28.6)	2400	(10.67)	1861	(844.1)
B3122-14	8 1/4"	(209.5)	1 1/2"	(38.1)	3130	(13.92)	3116	(1413.4)
B3122-16	9 7/16"	(239.7)	1 1/2"	(38.1)	3970	(17.66)	3550	(1610.3)
B3122-18	10 1/2"	(266.7)	1 1/2"	(38.1)	4200	(18.68)	4328	(1963.2)
B3122-20	11 1/2"	(292.1)	1 1/2"	(38.1)	4550	(20.24)	5241	(2377.3)
B3122-24	13 13/16"	(350.8)	2"	(50.8)	6160	(27.40)	7773	(3525.8)

Note: If using D.I. pipe refer to page 321 for sizing. Non-metallic rollers with hot-dip galvanized sockets and stainless steel hardware are available for most sizes (B3122NM-Pipe Size). Contact Eaton Engineering for more information.

All dimensions in charts and on drawings are in inches. Dimensions shown in parentheses are in millimeters unless otherwise specified.

Pipe Rollers & Roller Supports

B3122A - Adjustable Double Roller Guide

Size Range: 2" (50mm) thru 24" (600mm) pipe

Material: Cast iron roller and steel axle
(Non-metallic polyurethane rollers are available)

Function: Designed for supporting and guiding pipe where longitudinal movement and adjustment are required.

Approvals: Conforms to Federal Specification WW-H-171E & A-A-1192A, Type 42, 2" (50mm) thru 24" (600mm), and Manufacturers Standardization Society ANSI/MSS SP-69 & SP-58, Type 41

Note: When pipe line is insulated, total outside diameter of pipe and covering should be used to determine size of hanger; also see B3160 to B3165 on pages 158 thru 163.

Finish: Plain. Contact customer service for alternative finishes and materials.

Furnished With: B3114 Roller, two support rods and twelve HN Hex Nuts — not assembled.

Order By: Part number, pipe size and finish

Note: Not for continuous cycling applications.

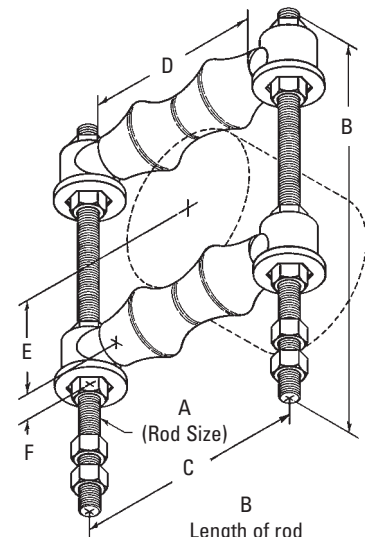

B
Length of rod
C
Center to center distance of rod.
D
Length of Roller
E
Center of axle to center of pipe.
F
Center of axle to bottom of socket.

Part No.	Pipe Size in. (mm)	Rod Size A	B in. (mm)	C in. (mm)	D in. (mm)
B3122A-2	2" (50)	3/8"-16	12" (304.8)	4 1/8" (104.8)	2 5/8" (66.7)
B3122A-2 1/2	2 1/2" (65)	1/2"-13	14" (355.6)	4 7/8" (123.8)	3 1/8" (79.4)
B3122A-3	3" (80)	1/2"-13	14" (355.6)	5 1/2" (139.7)	3 3/4" (95.2)
B3122A-3 1/2	3 1/2" (90)	1/2"-13	14" (355.6)	6 1/8" (155.6)	4 1/4" (107.9)
B3122A-4	4" (100)	5/8"-11	18" (457.2)	6 3/4" (171.4)	4 3/4" (120.6)
B3122A-5	5" (125)	5/8"-11	18" (457.2)	8 1/16" (204.8)	5 13/16" (147.6)
B3122A-6	6" (150)	3/4"-10	24" (609.6)	9 9/16" (242.9)	6 7/8" (174.6)
B3122A-8	8" (200)	7/8"-9	24" (609.6)	11 15/16" (303.2)	8 7/8" (225.4)
B3122A-10	10" (250)	7/8"-9	30" (762.0)	14 1/16" (357.2)	11" (279.4)
B3122A-12	12" (300)	7/8"-9	30" (762.0)	15 13/16" (401.6)	13" (330.2)
B3122A-14	14" (350)	1"-8	36" (914.4)	17 3/4" (450.8)	14 1/4" (361.9)
B3122A-16	16" (400)	1"-8	36" (914.4)	19 3/4" (501.6)	16 1/4" (412.7)
B3122A-18	18" (450)	1"-8	42" (1066.8)	21 7/8" (555.6)	18 1/4" (463.5)
B3122A-20	20" (500)	1 1/4"-7	42" (1066.8)	24 1/4" (615.9)	20 1/4" (514.3)
B3122A-24	24" (600)	1 1/2"-6	48" (1219.2)	28 7/8" (733.4)	24 1/4" (615.9)



Part No.	E in. (mm)	F in. (mm)	Design Load Lbs. (kN)	Approx. Wt./100 Lbs. (kg)
B3122A-2	1 9/16" (39.7)	3/4" (19.0)	600 (2.67)	323 (146.5)
B3122A-2 1/2	1 7/8" (47.6)	3/4" (19.0)	660 (2.93)	465 (210.9)
B3122A-3	2 3/16" (55.6)	3/4" (19.0)	700 (3.11)	501 (227.2)
B3122A-3 1/2	2 1/2" (63.5)	3/4" (19.0)	750 (3.33)	525 (238.1)
B3122A-4	2 3/4" (69.8)	3/4" (19.0)	750 (3.33)	757 (343.4)
B3122A-5	3 3/8" (85.7)	3/4" (19.0)	750 (3.33)	872 (395.5)
B3122A-6	3 15/16" (100.0)	1 1/8" (28.6)	1070 (4.76)	1687 (765.2)
B3122A-8	5 1/16" (128.6)	1 1/8" (28.6)	1350 (6.00)	2277 (1032.8)
B3122A-10	6 1/4" (158.7)	1 1/8" (28.6)	1730 (7.69)	2830 (1283.7)
B3122A-12	7 3/8" (187.3)	1 1/8" (28.6)	2400 (10.67)	3817 (1731.4)
B3122A-14	8 1/4" (209.5)	1 1/2" (38.1)	3130 (13.92)	6513 (2954.3)
B3122A-16	9 7/16" (242.9)	1 1/2" (38.1)	3970 (17.66)	6759 (3065.9)
B3122A-18	10 1/2" (266.7)	1 1/2" (38.1)	4200 (18.68)	7518 (3410.1)
B3122A-20	11 1/2" (292.1)	1 1/2" (38.1)	4550 (20.24)	11222 (5090.3)
B3122A-24	13 13/16" (350.8)	2" (50.8)	6160 (27.40)	17666 (8013.3)

Note: If using D.I. pipe refer to page 321 for sizing. Non-metallic rollers with hot-dip galvanized sockets and stainless steel hardware are available for most sizes (B3122ANM-Pipe Size). Contact Eaton Engineering for more information.

All dimensions in charts and on drawings are in inches. Dimensions shown in parentheses are in millimeters unless otherwise specified.

Pipe Rollers & Roller Supports

B3120 - Roller Chair

Size Range: 2" (50mm) thru 24" (600mm) pipe

Material: Cast iron roller and steel axle/base
(Non-metallic polyurethane rollers are available)

Function: For supporting pipe where movement may occur due to thermal expansion. Used when ceiling suspension is impractical.

Approvals: Conforms to Federal Specification WW-H-171E & A-A-1192A, Type 45 and Manufacturers Standardization Society ANSI/MSS SP-69 & SP-58, Type 44.

Note: When pipe line is insulated, total outside diameter of pipe and covering should be used to determine size of hanger; also see B3160 to B3165 on pages 158 thru 163.

Finish: Plain. Contact customer service for alternative finishes and materials.

Order by: Part number, pipe size and finish

Note: Not for continuous cycling applications.

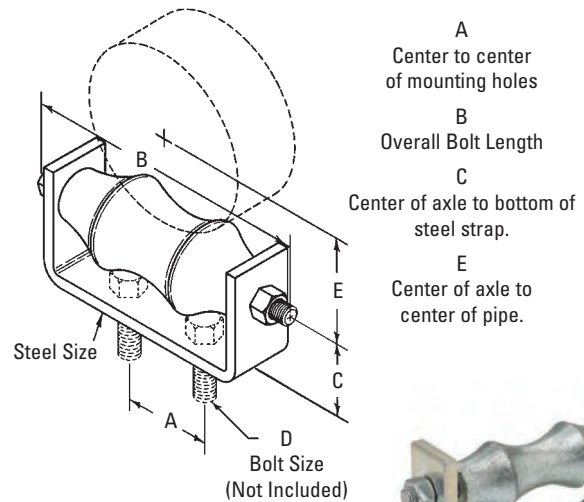

Note: If using D.I. pipe refer to page 321 for sizing. Non-metallic rollers with stainless steel chair and hardware are available for most sizes (B3120NM-Pipe Size). Contact Eaton Engineering for more information.

Part No.	Pipe Size		A		B		C		Recommended Bolt Size D (Not Included)
	in.	(mm)	in.	(mm)	in.	(mm)	in.	(mm)	
B3120-2	2"	(50)	1 1/4"	(31.7)	4 5/8"	(117.5)	1 1/2"	(38.1)	3/8"-16 x 1 1/2"
B3120-2 1/2	2 1/2"	(65)	1 1/4"	(31.7)	5 3/8"	(136.5)	1 5/8"	(41.3)	3/8"-16 x 1 1/2"
B3120-3	3"	(80)	2"	(50.8)	6"	(152.4)	1 3/4"	(44.4)	3/8"-16 x 1 1/2"
B3120-3 1/2	3 1/2"	(90)	2"	(50.8)	6 3/4"	(171.4)	2 1/16"	(52.4)	3/8"-16 x 1 1/2"
B3120-4	4"	(100)	2"	(50.8)	7 1/4"	(184.1)	2 5/16"	(58.7)	1/2"-13 x 1 1/2"
B3120-5	5"	(125)	3"	(76.2)	8 7/16"	(214.3)	2 1/2"	(63.5)	1/2"-13 x 1 1/2"
B3120-6	6"	(150)	3 1/8"	(79.4)	9 3/4"	(247.6)	2 3/4"	(69.8)	1/2"-13 x 1 1/2"
B3120-8	8"	(200)	3 3/8"	(85.7)	12"	(304.8)	3"	(76.2)	5/8"-11 x 1 1/2"
B3120-10	10"	(250)	5 1/4"	(133.3)	14 7/16"	(366.7)	3 5/8"	(92.1)	5/8"-11 x 2"
B3120-12	12"	(300)	5 1/2"	(139.7)	16 5/8"	(422.3)	4 1/8"	(104.8)	5/8"-11 x 2"
B3120-14	14"	(350)	6"	(152.4)	18 1/4"	(463.5)	4 5/8"	(117.5)	5/8"-11 x 2"
B3120-16	16"	(400)	8"	(203.2)	21"	(533.4)	5"	(127.0)	5/8"-11 x 2 1/2"
B3120-18	18"	(450)	9"	(228.6)	23"	(584.2)	5 1/4"	(133.3)	5/8"-11 x 2 1/2"
B3120-20	20"	(500)	10"	(254.0)	25"	(635.0)	5 3/4"	(146.0)	3/4"-10 x 3"
B3120-24	24"	(600)	12"	(304.8)	30"	(762.0)	7"	(177.8)	3/4"-10 x 3"

Part No.	E		Steel Size		Design Load	Approx. Wt./100	
	in.	(mm)	in.	(mm)		lbs.	(kg)
B3120-2	1 9/16"	(39.7)	1/4" x 1 1/4"	(6.3 x 31.7)	600	(2.67)	119 (54.0)
B3120-2 1/2	1 7/8"	(47.6)	1/4" x 1 1/4"	(6.3 x 31.7)	660	(2.93)	146 (66.2)
B3120-3	2 3/16"	(55.6)	1/4" x 1 1/4"	(6.3 x 31.7)	700	(3.11)	172 (78.0)
B3120-3 1/2	2 1/2"	(63.5)	3/8" x 1 1/2"	(9.5 x 38.1)	750	(3.33)	264 (119.7)
B3120-4	2 3/4"	(69.8)	3/8" x 1 1/2"	(9.5 x 38.1)	750	(3.33)	303 (137.4)
B3120-5	3 3/8"	(85.7)	3/8" x 1 1/2"	(9.5 x 38.1)	750	(3.33)	401 (181.9)
B3120-6	3 15/16"	(100.0)	3/8" x 2"	(9.5 x 50.8)	1070	(4.76)	620 (281.2)
B3120-8	5 1/16"	(128.6)	3/8" x 2"	(9.5 x 50.8)	1350	(6.00)	874 (396.4)
B3120-10	6 1/4"	(158.7)	1/2" x 2"	(12.7 x 50.8)	1730	(7.69)	1270 (576.1)
B3120-12	7 3/8"	(187.3)	1/2" x 2"	(12.7 x 50.8)	2400	(10.67)	1918 (870.0)
B3120-14	8 1/4"	(209.5)	1/2" x 2"	(12.7 x 50.8)	3130	(13.92)	2629 (1192.5)
B3120-16	9 1/4"	(234.9)	5/8" x 2 1/2"	(15.9 x 63.5)	3970	(17.66)	3248 (1473.3)
B3120-18	10 3/8"	(263.5)	5/8" x 2 1/2"	(15.9 x 63.5)	4200	(18.68)	4120 (1868.8)
B3120-20	11 1/2"	(292.1)	5/8" x 3"	(15.9 x 76.2)	4550	(20.24)	5630 (3553.7)
B3120-24	13 3/4"	(349.2)	3/4" x 3"	(19.0 x 76.2)	6160	(27.40)	7702 (3493.6)

All dimensions in charts and on drawings are in inches. Dimensions shown in parentheses are in millimeters unless otherwise specified.

Pipe Rollers & Roller Supports

B3124 - Roller Support

Size Range: 2" (50mm) thru 20" (500mm) pipe

Material: Cast iron roller and steel axle/base
(Non-metallic polyurethane rollers are available)

Function: Designed for supporting pipe where longitudinal movement and vertical adjustment are required.

Note: When pipe line is insulated, total outside diameter of pipe and covering should be used to determine size of hanger; also see B3160 to B3165 on pages 158 thru 163.

Finish: Plain. Contact customer service for alternative finishes and materials.

Order By: Part number, pipe size and finish

Note: Not for continuous cycling applications.

B
Overall Bolt Length
C
Center of axle to
center of pipe.
D
Overall Stud Height
E
Center of roller to
bottom of chair.

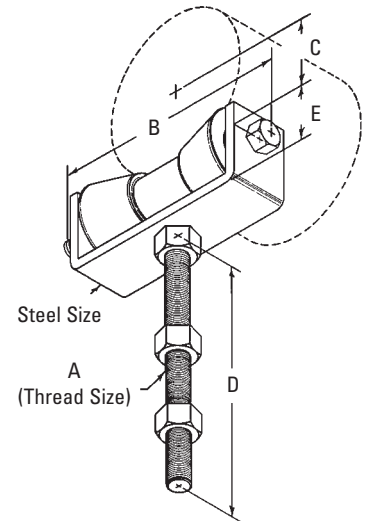

Part No.	Pipe Size in. (mm)	Thread Size A	B in. (mm)	C in. (mm)	D in. (mm)
B3124-2 to 3 1/2	2" (50)	5/8"-11	4 3/4" (120.6)	1 3/4" (44.4)	5" (127.0)
	2 1/2" (65)	5/8"-11	4 3/4" (120.6)	2 1/8" (54.0)	5" (127.0)
	3" (80)	5/8"-11	4 3/4" (120.6)	2 3/8" (60.3)	5" (127.0)
	3 1/2" (90)	5/8"-11	4 3/4" (120.6)	2 5/8" (66.7)	5" (127.0)
B3124-4 to 6	4" (100)	3/4"-10	5 7/8" (149.2)	2 3/4" (69.8)	6" (152.4)
	5" (125)	3/4"-10	5 7/8" (149.2)	3 3/8" (85.7)	6" (152.4)
	6" (150)	3/4"-10	5 7/8" (149.2)	4" (101.6)	6" (152.4)
B3124-8 to 10	8" (200)	7/8"-9	8 3/4" (222.2)	5 1/4" (133.3)	6" (152.4)
	10" (250)	7/8"-9	8 3/4" (222.2)	6 3/8" (161.9)	6" (152.4)
B3124-12 to 14	12" (300)	1"-8	11 1/4" (285.7)	7 1/2" (190.5)	7" (177.8)
	14" (350)	1"-8	11 1/4" (285.7)	8 1/8" (206.4)	7" (177.8)
B3124-16 to 20	16" (400)	1 1/8"-7	12 1/2" (317.5)	9 3/8" (238.1)	8" (203.2)
	18" (450)	1 1/8"-7	12 1/2" (317.5)	10 3/8" (263.5)	8" (203.2)
	20" (500)	1 1/8"-7	12 1/2" (317.5)	11 3/8" (288.9)	8" (203.2)

Note: If using D.I. pipe refer to page 321 for sizing. Non-metallic rollers with stainless steel chair and hardware are available for most sizes (B3124NM-Pipe Size). Contact Eaton Engineering for more information.

Part No.	E in. (mm)	Length of Roller in. (mm)	Steel Size in. (mm)	Design Load Lbs. (kN)	Approx. Wt./100 Lbs. (kg)
B3124-2 to 3 1/2	1 13/16" (46.0)	2 3/4" (69.8)	3/16" x 1 1/2" (4.8 x 38.1)	390 (1.73)	233 (105.7)
B3124-4 to 6	2" (50.8)	3 3/4" (95.2)	1/4" x 2" (6.3 x 50.8)	600 (2.67)	368 (166.9)
B3124-8 to 10	2 11/16" (68.3)	6" (152.4)	3/8" x 2" (9.5 x 50.8)	800 (3.56)	919 (416.8)
B3124-12 to 14	3 1/4" (82.5)	8" (203.2)	1/2" x 2" (12.7 x 50.8)	1300 (5.78)	1660 (753.0)
B3124-16 to 20	3 1/2" (88.9)	9" (228.6)	1/2" x 2" (12.7 x 50.8)	2300 (10.23)	2250 (1020.6)

All dimensions in charts and on drawings are in inches. Dimensions shown in parentheses are in millimeters unless otherwise specified.

Pipe Rollers & Roller Supports

B3126 Roller Support

Size Range: 2" (50mm) thru 20" (500mm) pipe

Material: Steel with Cast Iron Roller
(Non-metallic polyurethane rollers are available)

Function: Designed to mount on strut (metal framing) for the support of pipe with longitudinal movement.

Note: When pipe line is insulated, total outside diameter of pipe and covering should be used to determine size of hanger; also see B3160 to B3165 on pages 158 thru 163.

Finish: Plain. Contact customer service for alternative finishes and materials.

Order By: Part number, pipe size and finish

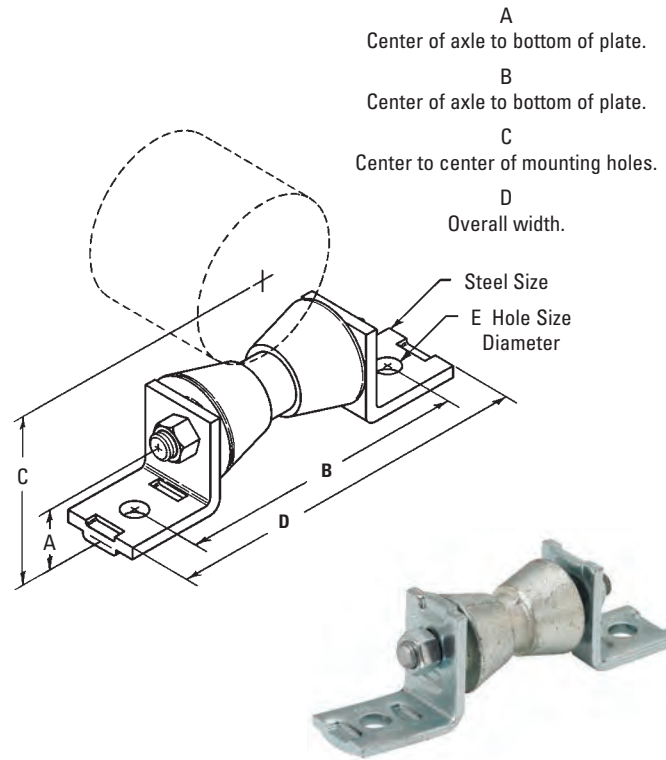

Part No.	Pipe Size in. (mm)	A		B		C		D	
		in.	(mm)	in.	(mm)	in.	(mm)	in.	(mm)
B3126-2 to 3 1/2	2" (50)	17/16"	(36.5)	6"	(152.4)	3 11/64"	(80.6)	7 5/8"	(193.7)
	2 1/2" (65)	17/16"	(36.5)	6"	(152.4)	3 27/64"	(86.9)	7 5/8"	(193.7)
	3" (80)	17/16"	(36.5)	6"	(152.4)	3 47/64"	(94.8)	7 5/8"	(193.7)
	3 1/2" (90)	17/16"	(36.5)	6"	(152.4)	3 63/64"	(101.2)	7 5/8"	(193.7)
B3126-4 to 6	4" (100)	17/16"	(36.5)	7"	(177.8)	4 13/64"	(106.8)	8 5/8"	(219.1)
	5" (125)	17/16"	(36.5)	7"	(177.8)	4 47/64"	(120.2)	8 5/8"	(219.1)
	6" (150)	17/16"	(36.5)	7"	(177.8)	5 17/64"	(133.8)	8 5/8"	(219.1)
B3126-8 to 10	8" (200)	1 13/16"	(46.0)	8 3/4"	(222.3)	7"	(177.8)	10 3/8"	(263.5)
	10" (250)	1 13/16"	(46.0)	8 3/4"	(222.3)	8 1/16"	(204.8)	10 3/8"	(263.5)
B3126-12 to 14	12" (300)	2 7/16"	(61.9)	12 1/8"	(308.0)	9 27/32"	(250.1)	14 3/8"	(365.1)
	14" (350)	2 7/16"	(61.9)	12 1/8"	(308.0)	10 15/32"	(265.9)	14 3/8"	(365.1)
B3126-16 to 20	16" (400)	2 5/8"	(66.7)	13 1/8"	(333.4)	11 7/8"	(301.6)	15 3/8"	(390.5)
	18" (450)	2 5/8"	(66.7)	13 1/8"	(333.4)	12 7/8"	(327.1)	15 3/8"	(390.5)
	20" (500)	2 5/8"	(66.7)	13 1/8"	(333.4)	13 7/8"	(352.4)	15 3/8"	(390.5)

Part No.	E		Steel Size		Design Load		Approx. Wt./100	
	in.	(mm)	in.	(mm)	Lbs.	(kN)	Lbs.	(kg)
B3126-2 to 3 1/2	9/16"	(14.3)	1/4" x 1 5/8"	(6.3 x 41.3)	390	(1.73)	177	(80.3)
B3126-4 to 6	9/16"	(14.3)	1/4" x 1 5/8"	(6.3 x 41.3)	600	(2.67)	231	(104.8)
B3126-8 to 10	9/16"	(14.3)	1/4" x 1 5/8"	(6.3 x 41.3)	800	(3.56)	542	(245.8)
B3126-12 to 14	1 3/16"	(20.6)	3/8" x 2"	(9.5 x 50.8)	1300	(5.78)	1040	(471.7)
B3126-16 to 20	1 3/16"	(20.6)	3/8" x 2"	(9.5 x 50.8)	2300	(10.23)	1508	(684.0)

Note: If using D.I. pipe refer to page 321 for sizing. Non-metallic rollers with stainless steel chair and hardware are available for most sizes (B3126NM-Pipe Size). Contact Eaton Engineering for more information.

All dimensions in charts and on drawings are in inches. Dimensions shown in parentheses are in millimeters unless otherwise specified.

Pipe Rollers & Roller Supports

B218 Pipe Rollers-1/2" (15mm) to 8" (200mm) Pipe

Size Range: 1/2" (15mm) thru 8" (200mm) pipe

Material: Steel with Malleable Iron Roller

Function: Designed to mount on strut (metal framing) for the support of pipe with longitudinal movement.

Note: When pipe line is insulated, total outside diameter of pipe and covering should be used to determine size of hanger; also see B3160 to B3165 on pages 158 thru 163.

Finish: Electro-Galvanized

Order By: Part number, pipe size and finish

Design Load: 500 Lbs. (2.22kN)

Weight: Approx. weight per 100 - 256.0 Lbs. (116.1kg)

Note: If using D.I. pipe refer to page 321 for sizing.
Not for continuous cycling applications.

Channel and mounting hardware not included.

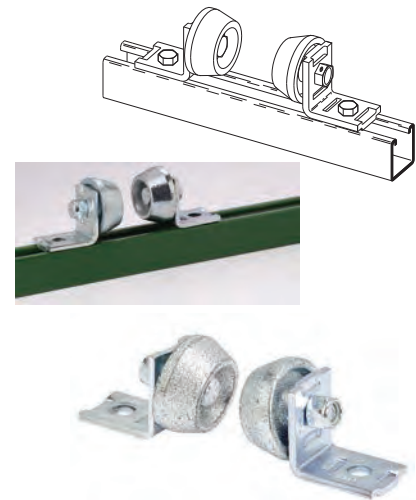
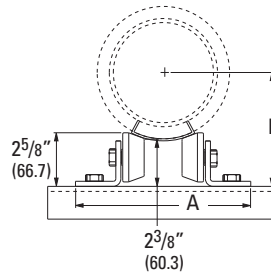

Reference Chart - A Dimension in. (mm)

Pipe Size	Insulation Thickness						
	0" (0.0mm)	1" (25.4mm)	1 1/2" (38.1mm)	2" (50.8mm)	2 1/2" (63.5mm)	3" (76.2mm)	4" (101.6mm)
1/2" (15)	7 1/4" (184.1)	-- --	-- --	-- --	-- --	-- --	-- --
3/4" (20)	7 1/4" (184.1)	7 1/4" (184.1)	7 5/8" (193.7)	8" (203.2)	-- --	-- --	-- --
1" (25)	7 1/4" (184.1)	7 1/4" (184.1)	7 5/8" (193.7)	8 1/4" (209.5)	-- --	-- --	-- --
1 1/4" (32)	7 1/4" (184.1)	7 1/4" (184.1)	8" (203.2)	8 1/4" (209.5)	-- --	-- --	-- --
1 1/2" (40)	7 1/4" (184.1)	7 5/8" (193.7)	8" (203.2)	8 1/2" (215.9)	9" (228.6)	-- --	-- --
2" (50)	7 1/4" (184.1)	7 5/8" (193.7)	8 1/2" (215.9)	8 1/2" (215.9)	9" (228.6)	-- --	-- --
2 1/2" (65)	7 1/4" (184.1)	8" (203.2)	8 1/2" (215.9)	9" (228.6)	10" (254.0)	-- --	-- --
3" (80)	7 1/4" (184.1)	8 1/2" (215.9)	9" (228.6)	9" (228.6)	10" (254.0)	10" (254.0)	-- --
3 1/2" (90)	7 1/4" (184.1)	8 1/2" (215.9)	9" (228.6)	10" (254.0)	10" (254.0)	10" (254.0)	-- --
4" (100)	7 5/8" (193.7)	9" (228.6)	9" (228.6)	10" (254.0)	10" (254.0)	10" (254.0)	-- --
5" (125)	8 1/2" (215.9)	9" (228.6)	10" (254.0)	10" (254.0)	11" (279.4)	11" (279.4)	12" (304.8)
6" (150)	9" (228.6)	10" (254.0)	10" (254.0)	11" (279.4)	11" (279.4)	11" (279.4)	12" (304.8)
8" (200)	10" (254.0)	11" (279.4)	11" (279.4)	11" (279.4)	12" (304.8)	-- --	-- --

Reference Chart - B Dimension in. (mm)

Pipe Size	Insulation Thickness						
	0" (0.0mm)	1" (25.4mm)	1 1/2" (38.1mm)	2" (50.8mm)	2 1/2" (63.5mm)	3" (76.2mm)	4" (101.6mm)
1/2" (15)	1 11/16" (68.3)	-- --	-- --	-- --	-- --	-- --	-- --
3/4" (20)	2 13/16" (71.4)	3 7/8" (98.4)	4 3/8" (111.1)	4 7/8" (123.8)	-- --	-- --	-- --
1" (25)	2 15/16" (74.6)	4 3/16" (106.4)	4 11/16" (119.1)	5 1/16" (128.6)	-- --	-- --	-- --
1 1/4" (32)	3 1/8" (79.4)	4 3/16" (106.4)	4 5/8" (117.5)	5 1/8" (130.2)	-- --	-- --	-- --
1 1/2" (40)	3 1/4" (82.5)	4 3/8" (111.1)	4 7/8" (123.8)	5 5/16" (134.9)	5 3/4" (146.0)	-- --	-- --
2" (50)	3 9/16" (90.5)	4 11/16" (119.1)	5 1/16" (128.6)	5 5/8" (142.9)	6 1/16" (154.0)	-- --	-- --
2 1/2" (65)	3 13/16" (96.8)	4 7/8" (123.8)	5 5/16" (134.9)	6" (152.4)	6 3/8" (161.9)	-- --	-- --
3" (80)	4 1/8" (104.8)	5 1/16" (128.6)	5 9/16" (141.3)	6 1/8" (155.6)	6 7/16" (163.5)	7" (177.8)	-- --
3 1/2" (90)	4 3/8" (111.1)	5 5/16" (134.9)	5 13/16" (147.6)	6 1/4" (158.7)	6 11/16" (169.9)	7 1/4" (184.1)	-- --
4" (100)	4 5/8" (117.5)	5 9/16" (141.3)	6 1/16" (154.0)	6 7/16" (163.5)	6 15/16" (176.2)	7 3/8" (187.3)	-- --
5" (125)	5 1/2" (127.0)	6 1/16" (154.0)	6 7/16" (163.5)	7" (177.8)	7 3/8" (187.3)	7 7/8" (200.0)	8 13/16" (223.8)
6" (150)	5 1/2" (139.7)	6 7/16" (163.5)	6 15/16" (176.2)	7 3/8" (187.3)	7 15/16" (201.6)	8 1/2" (215.9)	9 1/2" (241.3)
8" (200)	6 15/16" (160.3)	7 3/8" (187.3)	7 15/16" (201.6)	8 7/16" (214.3)	8 15/16" (227.0)	-- --	-- --

All dimensions in charts and on drawings are in inches. Dimensions shown in parentheses are in millimeters unless otherwise specified.

B219 Pipe Rollers 3/4" (15mm) to 12" (300mm) Pipe

Size Range: 1/2" (20mm) thru 12" (300mm) pipe

Material: Steel with Malleable Iron Roller

Function: Designed to mount on strut (metal framing) for the support of pipe with longitudinal movement.

Note: When pipe line is insulated, total outside diameter of pipe and covering should be used to determine size of hanger; also see B3160 to B3165 on pages 158 thru 163.

Finish: Electro-Galvanized

Order By: Part number, pipe size and finish

Design Load: 750 Lbs. (3.33kN)

Note: If using D.I. pipe refer to page 321 for sizing. Not for continuous cycling applications.

Channel and mounting hardware not included.

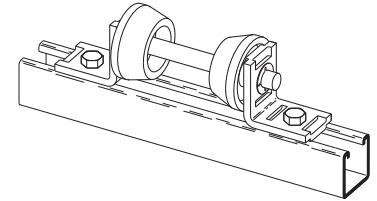
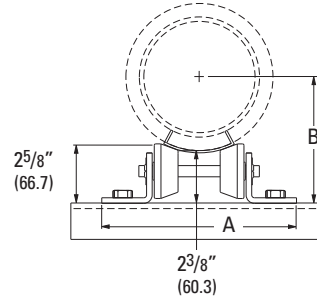

B219 Sizing Chart

Pipe Size	Insulation Thickness in. (mm)						
	0" (0.0)	1" (25.4)	1 1/2" (38.1)	2" (50.8)	2 1/2" (63.5)	3" (76.2)	4" (101.6)
1/2" (15)	B219	--	--	--	--	--	--
3/4" (20)	B219	B219	B219	B219-1	--	--	--
1" (25)	B219	B219	B219-1	B219-1	--	--	--
1 1/4" (32)	B219	B219	B219-1	B219-1	--	--	--
1 1/2" (40)	B219	B219	B219-1	B219-2	B219-2	--	--
2" (50)	B219	B219-1	B219-1	B219-2	B219-2	--	--
2 1/2" (65)	B219	B219-1	B219-2	B219-2	B219-3	--	--
3" (80)	B219	B219-1	B219-2	B219-2	B219-3	B219-3	--
3 1/2" (90)	B219-1	B219-2	B219-2	B219-3	B219-3	B219-4	--
4" (100)	B219-1	B219-2	B219-2	B219-3	B219-3	B219-4	--
5" (125)	B219-1	B219-2	B219-3	B219-3	B219-4	B219-4	B219-5
6" (150)	B219-2	B219-3	B219-3	B219-4	B219-4	B219-5	B219-5
8" (200)	B219-3	B219-4	B219-4	B219-5	B219-5	--	--
10" (250)	B219-4	B219-5	--	--	--	--	--
12" (300)	B219-5	--	--	--	--	--	--



Reference Chart - A Dimension

Part No.	A		Wt./100 Lbs. (kg)
	in.	(mm)	
B219	7 1/4"	(184.1)	253 (114.7)
B219-1	8"	(203.2)	258 (117.0)
B219-2	9"	(228.6)	263 (119.3)
B219-3	10"	(254.0)	269 (122.0)
B219-4	10 7/8"	(276.2)	274 (124.8)
B219-5	11 5/8"	(295.3)	279 (126.5)

Reference Chart - B Dimension in. (mm)

Pipe Size	Insulation Thickness						
	0" (0.0mm)	1" (25.4mm)	1 1/2" (38.1mm)	2" (50.8mm)	2 1/2" (63.5mm)	3" (76.2mm)	4" (101.6mm)
1/2" (15)	2 11/16" (68.3)	--	--	--	--	--	--
3/4" (20)	2 13/16" (71.4)	3 7/8" (98.4)	4 1/2" (114.3)	4 7/8" (123.8)	--	--	--
1" (25)	2 15/16" (74.6)	4 3/16" (106.4)	4 5/8" (117.5)	5 1/16" (128.6)	--	--	--
1 1/4" (32)	3 1/8" (79.4)	4 3/16" (106.4)	4 5/8" (117.5)	5 1/8" (130.2)	--	--	--
1 1/2" (40)	3 1/4" (82.5)	4 7/16" (112.7)	4 7/8" (123.8)	5 1/4" (133.3)	5 3/8" (146.0)	--	--
2" (50)	3 9/16" (90.5)	4 5/8" (117.5)	5 3/16" (131.8)	5 1/2" (139.7)	6 1/16" (154.0)	--	--
2 1/2" (65)	3 3/4" (95.2)	4 7/8" (123.8)	5 1/4" (133.3)	6" (152.4)	6 3/8" (161.9)	--	--
3" (80)	4 1/8" (104.8)	5 1/8" (130.2)	5 9/16" (141.3)	6 1/16" (154.0)	6 7/16" (163.5)	6 15/16" (176.2)	--
3 1/2" (90)	4 1/8" (107.9)	5 1/4" (133.3)	5 13/16" (147.6)	6 1/4" (158.7)	6 11/16" (169.9)	7 1/16" (179.4)	--
4" (100)	4 9/16" (115.9)	5 1/2" (139.7)	6 1/16" (154.0)	6 7/16" (163.5)	6 15/16" (176.2)	7 3/8" (187.3)	--
5" (125)	5 1/16" (128.6)	6 1/16" (154.0)	6 7/16" (163.5)	7" (177.8)	7 3/8" (187.3)	7 7/8" (200.0)	8 15/16" (211.1)
6" (150)	5 7/16" (138.1)	6 7/16" (163.5)	6 15/16" (176.2)	7 3/8" (187.3)	7 7/8" (200.0)	8 15/16" (211.1)	9 9/16" (242.9)
8" (200)	6 3/8" (161.9)	7 7/16" (188.9)	7 15/16" (201.6)	8 3/8" (212.7)	9" (228.6)	--	--
10" (250)	7 5/16" (185.7)	8 3/16" (208.0)	--	--	--	--	--
12" (300)	8 1/4" (209.5)	--	--	--	--	--	--

All dimensions in charts and on drawings are in inches. Dimensions shown in parentheses are in millimeters unless otherwise specified.

Pipe Rollers & Roller Supports

B379 Pipe Roller - 6" (150mm) to 18" (450mm) Pipe

Size Range: 6" (150mm) thru 18" (450mm) pipe

Material: Steel with Malleable Iron Roller

Function: Designed to mount on strut (metal framing) for the support of pipe with longitudinal movement.

Note: When pipe line is insulated, total outside diameter of pipe and covering should be used to determine size of hanger; also see B3160 to B3165 on pages 158 thru 163.

Finish: Electro-Galvanized

Order By: Part number, pipe size and finish

Design Load: 1500 Lbs. (6.67kN)

Weight: Approx. weight per 100 - 558.0 Lbs. (253.1kg)

Note: If using D.I. pipe refer to page 321 for sizing.
Not for continuous cycling applications.

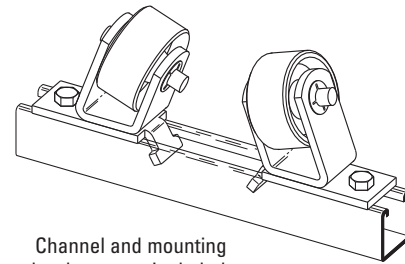

Channel and mounting hardware not included.

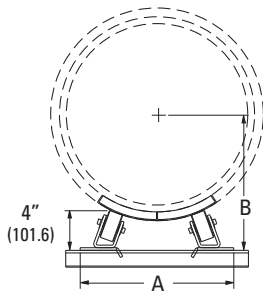

Reference Chart - A Dimension in. (mm)

Pipe Size	Insulation Thickness						
	0" (0.0mm)	1" (25.4mm)	1 1/2" (38.1mm)	2" (50.8mm)	2 1/2" (63.5mm)	3" (76.2mm)	4" (101.6mm)
6" (150)	9 ⁹ / ₁₆ " (242.9)	10 ³ / ₁₆ " (258.8)	10 ⁵ / ₈ " (269.9)	11" (279.4)	11 ³ / ₈ " (288.9)	11 ³ / ₄ " (298.4)	12 ¹ / ₂ " (317.5)
8" (200)	10 ¹ / ₄ " (260.3)	11 ¹ / ₁₆ " (281.0)	11 ³ / ₈ " (288.9)	11 ³ / ₄ " (298.4)	12 ³ / ₁₆ " (309.6)	12 ¹ / ₂ " (317.5)	13 ¹ / ₄ " (336.5)
10" (250)	11" (279.4)	11 ³ / ₄ " (298.4)	12 ¹ / ₈ " (308.0)	12 ¹ / ₂ " (317.5)	12 ¹³ / ₁₆ " (325.4)	13 ¹ / ₈ " (333.4)	13 ⁷ / ₈ " (352.4)
12" (300)	11 ¹¹ / ₁₆ " (296.9)	12 ⁹ / ₁₆ " (319.1)	12 ⁷ / ₈ " (327.0)	13 ¹ / ₄ " (336.5)	13 ⁹ / ₁₆ " (344.5)	13 ⁷ / ₈ " (352.4)	14 ⁵ / ₈ " (371.5)
14" (350)	12 ¹ / ₁₆ " (306.4)	12 ⁷ / ₈ " (327.0)	13 ³ / ₁₆ " (335.0)	13 ⁹ / ₁₆ " (344.5)	13 ⁷ / ₈ " (352.4)	14 ¹ / ₄ " (361.9)	14 ⁷ / ₈ " (377.8)
16" (400)	12 ³ / ₄ " (323.8)	13 ¹ / ₂ " (342.9)	13 ⁷ / ₈ " (352.4)	14 ¹³ / ₁₆ " (360.4)	14 ¹ / ₂ " (368.3)	14 ⁷ / ₈ " (377.8)	15 ¹ / ₂ " (393.7)
18" (450)	13 ¹ / ₂ " (342.9)	14 ¹ / ₄ " (361.9)	14 ⁵ / ₈ " (371.5)	15" (381.0)	15 ⁵ / ₁₆ " (388.9)	15 ⁵ / ₈ " (396.9)	16 ⁵ / ₁₆ " (414.3)

Reference Chart - B Dimension in. (mm)

Pipe Size	Insulation Thickness						
	0" (0.0mm)	1" (25.4mm)	1 1/2" (38.1mm)	2" (50.8mm)	2 1/2" (63.5mm)	3" (76.2mm)	4" (101.6mm)
6" (150)	6 ⁷ / ₈ " (174.6)	7 ⁷ / ₈ " (200.0)	8 ³ / ₈ " (212.7)	8 ⁷ / ₈ " (225.4)	9 ³ / ₈ " (238.1)	9 ⁷ / ₈ " (250.8)	10 ¹⁵ / ₁₆ " (277.8)
8" (200)	7 ¹³ / ₁₆ " (198.4)	8 ⁷ / ₈ " (225.4)	9 ³ / ₈ " (238.1)	9 ⁷ / ₈ " (250.8)	10 ⁷ / ₁₆ " (265.1)	10 ¹⁵ / ₁₆ " (277.8)	11 ⁷ / ₈ " (301.6)
10" (250)	8 ¹³ / ₁₆ " (223.8)	9 ⁷ / ₈ " (250.8)	10 ⁷ / ₁₆ " (265.1)	10 ¹⁵ / ₁₆ " (277.8)	11 ³ / ₈ " (288.9)	11 ⁷ / ₈ " (301.6)	12 ¹³ / ₁₆ " (325.4)
12" (300)	9 ³ / ₄ " (247.6)	10 ¹⁵ / ₁₆ " (277.8)	11 ³ / ₈ " (288.9)	11 ⁷ / ₈ " (301.6)	12 ⁵ / ₁₆ " (312.7)	12 ¹³ / ₁₆ " (325.4)	13 ³ / ₄ " (349.2)
14" (350)	10 ⁵ / ₁₆ " (261.9)	11 ³ / ₈ " (288.9)	11 ⁷ / ₈ " (301.6)	12 ⁵ / ₁₆ " (312.7)	12 ¹³ / ₁₆ " (325.4)	13 ¹ / ₄ " (336.5)	14 ¹ / ₄ " (361.9)
16" (400)	11 ⁵ / ₁₆ " (287.3)	12 ⁵ / ₁₆ " (312.7)	12 ¹³ / ₁₆ " (325.4)	13 ¹ / ₄ " (336.5)	13 ³ / ₄ " (349.2)	14 ¹ / ₄ " (361.9)	15 ¹ / ₈ " (384.2)
18" (450)	12 ¹ / ₄ " (311.1)	13 ¹ / ₄ " (336.5)	13 ³ / ₄ " (349.2)	14 ³ / ₁₆ " (360.4)	14 ¹¹ / ₁₆ " (373.1)	15 ¹ / ₈ " (384.2)	16 ¹ / ₁₆ " (408.0)

All dimensions in charts and on drawings are in inches. Dimensions shown in parentheses are in millimeters unless otherwise specified.

Pipe Rollers & Roller Supports

B479 Pipe Roller - 16" (400mm) to 30" (750mm) Pipe

Size Range: 16" (400mm) thru 30" (750mm) pipe

Material: Steel with Malleable Iron Roller

Function: Designed to mount on strut (metal framing) for the support of pipe with longitudinal movement.

Note: When pipe line is insulated, total outside diameter of pipe and covering should be used to determine size of hanger; also see B3160 to B3165 on pages 158 thru 163.

Finish: Electro-Galvanized

Order By: Part number, pipe size and finish

Design Load: 2000 Lbs. (8.89kN)

Weight: Approx. weight per 100 - 889.0 Lbs. (403.2kg)

Note: If using D.I. pipe refer to page 321 for sizing. Not for continuous cycling applications.

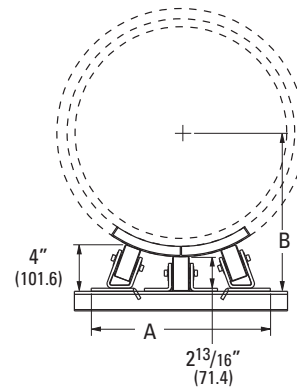
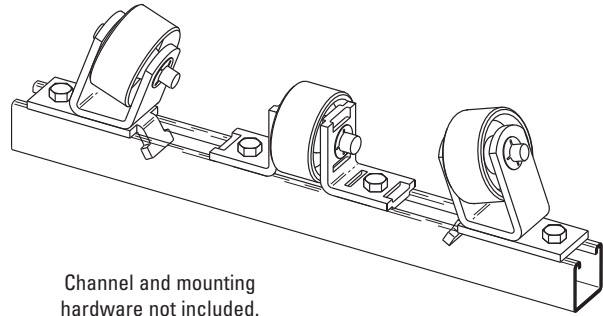

Reference Chart - A Dimension in. (mm)

Pipe Size	Insulation Thickness						
	0" (0.0mm)	1" (25.4mm)	1 1/2" (38.1mm)	2" (50.8mm)	2 1/2" (63.5mm)	3" (76.2mm)	4" (101.6mm)
16" (400)	15 ³ / ₁₆ " (385.8)	15 ⁵ / ₈ " (396.9)	15 ⁷ / ₈ " (403.2)	16" (406.4)	16 ¹ / ₄ " (412.7)	16 ¹ / ₂ " (419.1)	17" (431.8)
18" (450)	15 ¹ / ₂ " (393.7)	16" (406.4)	16 ³ / ₁₆ " (411.2)	16 ³ / ₈ " (415.9)	16 ⁹ / ₁₆ " (420.7)	16 ³ / ₄ " (425.4)	17 ³ / ₁₆ " (436.6)
20" (500)	16" (406.4)	16 ³ / ₈ " (415.9)	16 ⁹ / ₁₆ " (420.7)	16 ⁷ / ₈ " (428.6)	16 ¹⁵ / ₁₆ " (430.2)	17 ³ / ₁₆ " (436.6)	17 ¹ / ₂ " (444.5)
24" (600)	16 ¹³ / ₁₆ " (427.0)	17 ⁵ / ₁₆ " (439.7)	17 ¹ / ₂ " (444.5)	17 ¹ / ₂ " (444.5)	17 ¹¹ / ₁₆ " (449.3)	17 ⁷ / ₈ " (454.0)	18 ¹ / ₈ " (460.4)
30" (750)	17 ¹³ / ₁₆ " (452.4)	18 ¹ / ₄ " (463.5)	18 ³ / ₈ " (466.7)	18 ⁹ / ₁₆ " (471.5)	18 ⁷ / ₈ " (476.2)	18 ⁷ / ₈ " (476.2)	19 ¹ / ₄ " (488.9)

Reference Chart - B Dimension in. (mm)

Pipe Size	Insulation Thickness						
	0" (0.0mm)	1" (25.4mm)	1 1/2" (38.1mm)	2" (50.8mm)	2 1/2" (63.5mm)	3" (76.2mm)	4" (101.6mm)
16" (400)	10 ¹³ / ₁₆ " (274.6)	11 ¹⁵ / ₁₆ " (303.2)	12 ³ / ₈ " (314.3)	12 ¹⁵ / ₁₆ " (328.6)	13 ³ / ₈ " (339.7)	13 ¹⁵ / ₁₆ " (354.0)	14 ¹⁵ / ₁₆ " (379.4)
18" (450)	11 ⁷ / ₈ " (301.6)	12 ¹⁵ / ₁₆ " (328.6)	13 ⁷ / ₁₆ " (341.3)	13 ¹⁵ / ₁₆ " (354.0)	14 ⁷ / ₁₆ " (366.7)	14 ¹⁵ / ₁₆ " (379.4)	15 ¹⁵ / ₁₆ " (404.8)
20" (500)	12 ³ / ₁₆ " (325.4)	13 ¹⁵ / ₁₆ " (354.0)	14 ⁷ / ₁₆ " (366.7)	14 ⁷ / ₈ " (377.8)	15 ⁷ / ₁₆ " (392.1)	15 ⁷ / ₈ " (403.2)	16 ¹⁵ / ₁₆ " (430.2)
24" (600)	14 ¹³ / ₁₆ " (376.2)	15 ⁷ / ₈ " (403.2)	16 ³ / ₈ " (415.9)	16 ⁷ / ₈ " (428.6)	17 ³ / ₈ " (441.3)	17 ⁷ / ₈ " (454.0)	18 ⁷ / ₈ " (479.4)
30" (750)	17 ¹³ / ₁₆ " (452.4)	18 ⁷ / ₈ " (476.2)	19 ³ / ₈ " (492.1)	19 ⁷ / ₈ " (504.8)	20 ³ / ₈ " (517.5)	20 ⁵ / ₁₆ " (531.8)	21 ¹⁵ / ₁₆ " (557.2)

All dimensions in charts and on drawings are in inches. Dimensions shown in parentheses are in millimeters unless otherwise specified.

Pipe Rollers & Roller Supports

B3117SL Steel Roller Stand

Size Range: 2" (50mm) thru 42" (1067mm)

Material: Cast Iron Roller and Steel Base
(Non-metallic polyurethane rollers are available)

Function: Designed to support pipe where movement may occur due to thermal expansion. When used with insulated pipe, see B3160-B3165 pipe covering protection saddle charts for proper sizing on pages 158 thru 163.

Approvals: Conforms to Federal Specification WW-H-171E & A-A-1192A, Type 45 and Manufacturers Standardization Society ANSI/MSS SP-69 & SP-58, Type 44.

Standard Finish: Plain, Available in Electro-Galvanized and HDG finish or Stainless Steel material

Order By: Part number and finish.

Note: Not for continuous cycling applications.

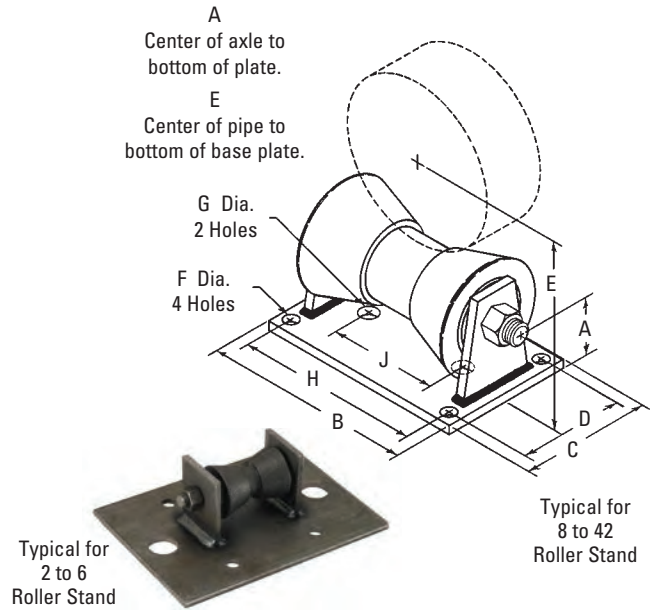

Part No.	Pipe Size in. (mm)	A		B		C		D		E		F	
		in.	(mm)	in.	(mm)	in.	(mm)	in.	(mm)	in.	(mm)	in.	(mm)
B3117SL-2 to 3 1/2	2" (50)	1 3/4"	(44.4)	8 3/8"	(212.7)	6"	(152.4)	4"	(101.6)	3 11/16"	(93.7)	1/2"	(12.7)
	2 1/2" (65)	1 3/4"	(44.4)	8 3/8"	(212.7)	6"	(152.4)	4"	(101.6)	3 15/16"	(100.0)	1/2"	(12.7)
	3" (80)	1 3/4"	(44.4)	8 3/8"	(212.7)	6"	(152.4)	4"	(101.6)	4 1/4"	(107.9)	1/2"	(12.7)
	3 1/2" (90)	1 3/4"	(44.4)	8 3/8"	(212.7)	6"	(152.4)	4"	(101.6)	4 1/2"	(114.3)	1/2"	(12.7)
B3117SL-4 to 6	4" (100)	2 1/16"	(52.4)	9 7/8"	(250.8)	6"	(152.4)	4 1/4"	(107.9)	5"	(127.0)	1/2"	(12.7)
	5" (125)	2 1/16"	(52.4)	9 7/8"	(250.8)	6"	(152.4)	4 1/4"	(107.9)	5 9/16"	(141.3)	1/2"	(12.7)
	6" (150)	2 1/16"	(52.4)	9 7/8"	(250.8)	6"	(152.4)	4 1/4"	(107.9)	6 1/16"	(154.0)	1/2"	(12.7)
B3117SL-8 to 10	8" (200)	3 7/16"	(87.3)	8 5/8"	(219.1)	8"	(203.2)	5"	(127.0)	8 13/16"	(223.8)	5/8"	(15.9)
	10" (250)	3 7/16"	(87.3)	8 5/8"	(219.1)	8"	(203.2)	5"	(127.0)	9 7/8"	(250.8)	5/8"	(15.9)
B3117SL-12 to 14	12" (300)	3 7/8"	(98.4)	10 15/16"	(277.8)	8"	(203.2)	6"	(152.4)	11 7/16"	(290.5)	5/8"	(15.9)
	14" (350)	3 7/8"	(98.4)	10 15/16"	(277.8)	8"	(203.2)	6"	(152.4)	12 1/16"	(306.4)	5/8"	(15.9)
B3117SL-16 to 20	16" (400)	4 1/4"	(107.9)	12 3/8"	(314.3)	10"	(254.0)	6 1/2"	(165.1)	13 5/8"	(346.1)	13/16"	(20.6)
	18" (450)	4 1/4"	(107.9)	12 3/8"	(314.3)	10"	(254.0)	6 1/2"	(165.1)	14 11/16"	(373.1)	13/16"	(20.6)
	20" (500)	4 1/4"	(107.9)	12 3/8"	(314.3)	10"	(254.0)	6 1/2"	(165.1)	15 11/16"	(398.5)	13/16"	(20.6)
B3117SL-24	24" (600)	4 3/8"	(111.1)	13 1/2"	(342.9)	10 3/4"	(273.0)	6 1/2"	(165.1)	17 11/16"	(449.3)	13/16"	(20.6)
B3117SL-30	30" (750)	5 1/8"	(130.2)	17"	(431.8)	10 3/4"	(273.0)	8"	(203.2)	21 3/4"	(552.4)	1 1/16"	(27.0)
B3117SL-36 to 42	36" (900)	5 3/4"	(146.0)	20"	(508.0)	12"	(304.8)	9"	(203.2)	25 5/16"	(642.9)	1 3/16"	(30.2)
	42" (1050)	5 3/4"	(146.0)	20"	(508.0)	12"	(304.8)	9"	(203.2)	28 5/16"	(719.1)	1 3/16"	(30.2)

Part No.	Dia. G in. (mm)	H in. (mm)	J in. (mm)	Design Load Lbs. (kN)	Approx. Wt./100 Lbs. (kg)
B3117SL-4 to 6	1" (25.4)	4 11/16" (119.1)	7 7/8" (200.0)	950 (4.22)	631 (286.2)
B3117SL-8 to 10	1" (25.4)	7" (177.8)	4" (101.6)	2100 (9.34)	1271 (576.5)
B3117SL-12 to 14	1" (25.4)	9 1/16" (230.2)	5 3/4" (146.0)	3075 (13.68)	1994 (904.5)
B3117SL-16 to 20	1" (25.4)	10 1/4" (260.3)	6 3/4" (171.4)	4980 (22.15)	3423 (1552.7)
B3117SL-24	1" (25.4)	11 3/8" (288.9)	7 1/2" (190.5)	6100 (27.13)	4710 (2136.4)
B3117SL-30	1" (25.4)	14 1/4" (361.9)	10" (254.0)	7500 (33.36)	7132 (3235.1)
B3117SL-36 to 42	1" (25.4)	17" (431.8)	12" (304.8)	12000 (53.37)	10386 (4711.1)

Note: If using D.I. pipe refer to page 321 for sizing. Non-metallic rollers with stainless steel bases are available for most sizes (B3117SLNM-Pipe Size). Contact Eaton Engineering for more information.

All dimensions in charts and on drawings are in inches. Dimensions shown in parentheses are in millimeters unless otherwise specified.

Pipe Rollers & Roller Supports

B3118SL Adjustable Roller Stand with Base Plate

Size Range: 2" (50mm) thru 30" (750mm)

Material: Cast Iron Roller and Steel Base
(Non-metallic polyurethane rollers are available)

Function: Designed to support pipe where movement may occur due to thermal expansion. Set screws allow for vertical adjustment. When used with insulated pipe, see B3160-B3165 pipe covering protection saddle charts for proper sizing on pages 158 thru 163.

Approvals: Conforms to Federal Specification WW-H-171E & A-A-1192A, Type 47 and Manufacturers Standardization Society ANSI/MSS SP-69 & SP-58, Type 46.

Finish: Plain, Available in Electro-Galvanized and HDG finish or Stainless Steel material

Order by: Part number and finish.

Note: Not for continuous cycling applications.

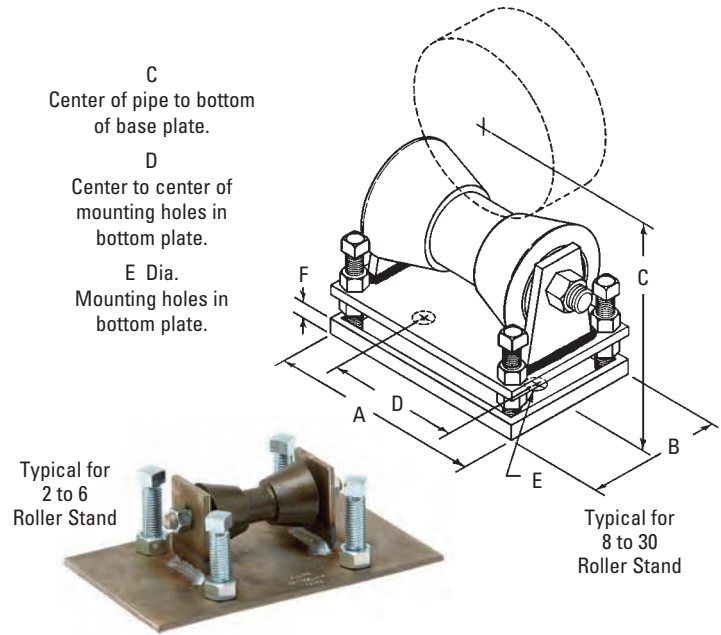

Part No.	Pipe Size in. (mm)	A in. (mm)	B in. (mm)	Minimum in. (mm)	C in. (mm)	Maximum in. (mm)	D in. (mm)
B3118SL-2 to 3 1/2	2" (50)	6 7/8" (174.6)	6" (152.4)	4 3/4" (120.6)	5 5/8" (142.9)	5 7/8" (142.9)	3 7/8" (98.4)
	2 1/2" (65)	6 7/8" (174.6)	6" (152.4)	5" (127.0)	5 7/8" (142.9)	5 7/8" (142.9)	3 7/8" (98.4)
	3" (80)	6 7/8" (174.6)	6" (152.4)	5 5/16" (134.9)	6 3/16" (157.2)	6 3/16" (157.2)	3 7/8" (98.4)
	3 1/2" (90)	6 7/8" (174.6)	6" (152.4)	5 9/16" (141.3)	6 7/16" (163.5)	6 7/16" (163.5)	3 7/8" (98.4)
B3118SL-4 to 6	4" (100)	8 1/8" (206.4)	6" (152.4)	6 3/16" (157.2)	7 7/16" (188.9)	7 7/16" (188.9)	5 1/8" (130.2)
	5" (125)	8 1/8" (206.4)	6" (152.4)	6 3/4" (171.4)	8" (203.2)	8" (203.2)	5 1/8" (130.2)
	6" (150)	8 1/8" (206.4)	6" (152.4)	7 1/4" (184.1)	8 1/2" (215.9)	8 1/2" (215.9)	5 1/8" (130.2)
B3118SL-8 to 10	8" (200)	10 5/8" (269.9)	8" (203.2)	10 1/8" (257.2)	11 11/16" (296.9)	11 11/16" (296.9)	7 3/8" (187.3)
	10" (250)	10 5/8" (269.9)	8" (203.2)	11 3/16" (284.2)	12 3/4" (323.8)	12 3/4" (323.8)	7 3/8" (187.3)
B3118SL-12 to 14	12" (300)	13" (330.2)	8" (203.2)	12 3/4" (323.8)	14 1/8" (358.8)	14 1/8" (358.8)	9 1/2" (241.3)
	14" (350)	13" (330.2)	8" (203.2)	13 3/8" (339.7)	14 3/8" (365.1)	14 3/8" (365.1)	9 1/2" (241.3)
B3118SL-16 to 20	16" (400)	14 5/8" (371.5)	10" (254.0)	15 3/8" (390.5)	17 1/4" (438.1)	17 1/4" (438.1)	11 1/8" (282.6)
	18" (450)	14 5/8" (371.5)	10" (254.0)	16 3/8" (415.9)	18 1/4" (463.5)	18 1/4" (463.5)	11 1/8" (282.6)
	20" (500)	14 5/8" (371.5)	10" (254.0)	17 3/8" (441.3)	19 1/4" (488.9)	19 1/4" (488.9)	11 1/8" (282.6)
B3118SL-24	24" (600)	15 3/4" (400.0)	10" (254.0)	19 1/4" (488.9)	21 1/4" (539.7)	21 1/4" (539.7)	12 1/4" (311.1)
B3118SL-30	30" (750)	19 1/4" (488.9)	10 1/2" (266.7)	24 7/16" (620.7)	26 11/16" (677.9)	26 11/16" (677.9)	15 3/4" (400.0)

Part No.	E in. (mm)	F in. (mm)	Design Load Lbs. (kN)	Approx. Wt./100 Lbs. (kg)
B3118SL-2 to 3 1/2	1" (25.4)	1" (25.4)	390 (1.73)	1100 (498.9)
B3118SL-4 to 6	1" (25.4)	1" (25.4)	950 (4.22)	1310 (594.2)
B3118SL-8 to 10	1" (25.4)	1 1/8" (28.6)	2100 (9.34)	2725 (1236.0)
B3118SL-12 to 14	1" (25.4)	1 1/8" (28.6)	3075 (13.68)	3612 (1638.4)
B3118SL-16 to 20	1" (25.4)	1 1/4" (31.7)	4980 (22.15)	6384 (2895.8)
B3118SL-24	1" (25.4)	1 3/8" (34.9)	6100 (27.13)	8437 (3827.0)
B3118SL-30	1" (25.4)	1 3/8" (34.9)	7500 (33.36)	12528 (5682.7)

Note: If using D.I. pipe refer to page 321 for sizing. Non-metallic rollers with stainless steel bases are available for most sizes (B3118LNM-Pipe Size). Contact Eaton Engineering for more information.

Pipe Rollers & Pipe Supports

All dimensions in charts and on drawings are in inches. Dimensions shown in parentheses are in millimeters unless otherwise specified.

Pipe Rollers & Roller Supports

B3119SL Roller with Steel Base Plate

Size Range: — 2" (50mm) thru 30" (750mm) pipe

Material: — Steel with Cast Iron Roller
(Non-metallic polyurethane rollers are available)

Function: — Designed for the support of pipe with longitudinal movement.

Note: — When pipe line is insulated, total outside diameter of pipe and covering should be used to determine size of hanger; also see B3160 to B3165 on pages 158 thru 163.

Approvals: Conforms to Federal Specification WW-H-171E & A-A-1192A, Type 46 and Manufacturers Standardization Society ANSI/MSS SP-69 & SP-58, Type 45.

Finish: — Plain. Contact customer service for alternative finishes and materials.

Order By: Part number, pipe size and finish

Note: Not for continuous cycling applications.

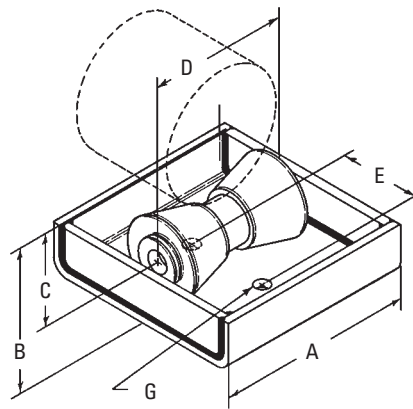

- B Center of pipe to bottom of plate.
- C Center of pipe to center of roller.
- D Length of Roller
- E Center to center of mounting holes in bottom plate.
- F Roller Travel
- G Dia.
1 hole for sizes 2 thru 6
2 holes for sizes 8 thru 30



4 to 6 Roller Stand shown

Part No.	Pipe Size in. (mm)	Structural Channel Size	A		B		C		D		E	
			in.	(mm)	in.	(mm)	in.	(mm)	in.	(mm)	in.	(mm)
B3119SL-2 to 3 1/2	2" (50)	C4 x 5.4	4 3/4"	(120.6)	3 1/16"	(77.8)	1 15/16"	(49.2)	2 3/4"	(69.8)	-	-
	2 1/2" (65)		4 3/4"	(120.6)	3 5/16"	(84.1)	2 3/16"	(55.6)	2 3/4"	(69.8)	-	-
	3" (80)		4 3/4"	(120.6)	3 5/8"	(92.1)	2 1/2"	(63.5)	2 3/4"	(69.8)	-	-
	3 1/2" (90)		4 3/4"	(120.6)	3 7/8"	(98.4)	2 3/4"	(69.8)	2 3/4"	(69.8)	-	-
B3119SL-4 to 6	4" (100)	C5 x 6.7	5 3/4"	(146.0)	4 1/8"	(104.8)	2 15/16"	(74.6)	3 3/4"	(95.2)	-	-
	5" (125)		5 3/4"	(146.0)	4 11/16"	(119.1)	3 1/2"	(88.9)	3 3/4"	(95.2)	-	-
	6" (150)		5 3/4"	(146.0)	5 3/16"	(131.8)	4"	(101.6)	3 3/4"	(95.2)	-	-
B3119SL-8 to 10	8" (200)	C6 x 8.2	8"	(203.2)	7 3/16"	(182.6)	5 3/8"	(136.5)	6"	(152.4)	3"	(76.2)
	10" (250)		8"	(203.2)	8 1/4"	(209.5)	6 7/16"	(163.5)	6"	(152.4)	3"	(76.2)
B3119SL-12 to 14	12" (300)	C8 x 11.5	10"	(254.0)	9 13/16"	(249.2)	7 9/16"	(192.1)	8"	(203.2)	4"	(101.6)
	14" (350)		10"	(254.0)	10 7/16"	(265.1)	8 3/16"	(208.0)	8"	(203.2)	4"	(101.6)
B3119SL-16 to 20	16" (400)	C8 x 11.5	11"	(279.4)	11 7/8"	(301.6)	9 3/8"	(238.1)	9"	(228.6)	4"	(101.6)
	18" (450)		11"	(279.4)	12 15/16"	(328.6)	10 7/16"	(265.1)	9"	(228.6)	4"	(101.6)
	20" (500)		11"	(279.4)	13 15/16"	(354.0)	11 7/16"	(290.5)	9"	(228.6)	4"	(101.6)
B3119SL-24	24" (600)	C8 x 11.5	12"	(304.8)	15 13/16"	(401.6)	13 5/16"	(338.1)	10"	(254.0)	4"	(101.6)
B3119SL-30	30" (750)	C10 x 15.3	14 1/2"	(368.3)	19 5/8"	(498.5)	16 5/8"	(422.3)	12 1/2"	(317.5)	6"	(152.4)

Part No.	F		Dia. G		Design Load Lbs. (kN)	Approx. Wt./100 Lbs. (kg)
	in.	(mm)	in.	(mm)		
B3119SL-2 to 3 1/2	1 3/4"	(44.4)	9/16"	(14.3)	390 (1.73)	314 (142.3)
B3119SL-4 to 6	2 1/2"	(63.5)	1 1/16"	(17.5)	950 (4.22)	489 (225.9)
B3119SL-8 to 10	2 1/2"	(63.5)	1 3/16"	(20.6)	2100 (9.34)	950 (430.9)
B3119SL-12 to 14	3 5/8"	(92.1)	1 3/16"	(20.6)	3075 (13.68)	1741 (789.7)
B3119SL-16 to 20	3 1/8"	(79.4)	1 3/16"	(20.6)	4980 (22.15)	2018 (915.3)
B3119SL-24	3 1/8"	(79.4)	1 3/16"	(20.6)	6100 (27.13)	2175 (986.6)
B3119SL-30	4 1/8"	(104.8)	1 3/16"	(20.6)	7500 (33.36)	3510 (1592.1)

Note: If using D.I. pipe refer to page 321 for sizing. Non-metallic rollers with stainless steel bases are available for most sizes (B3119LNM-Pipe Size). Contact Eaton Engineering for more information.

All dimensions in charts and on drawings are in inches. Dimensions shown in parentheses are in millimeters unless otherwise specified.

B3264 - Spring Cushion Hanger

Size Range: 2" (50mm) thru 30" (750mm) pipe

Material: Steel

Function: Designed for use with B3114 as a cushion spring for a piping system where vertical movement does not exceed 1¹/₄" (31.7mm).

Approvals: Conforms to Federal Specification WW-H-171E & A-A-1192A, Type 50 and Manufacturers Standardization Society ANSI/MSS SP-69 & SP-58, Type 49.

Order By: Part number

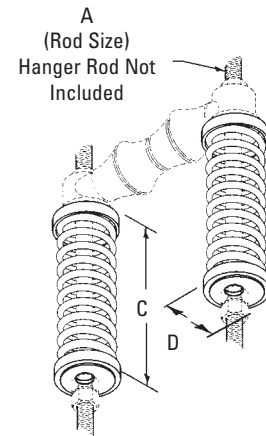

Includes:
2 Springs
4 Cup Washers



Part No.	Rod Size A	Free Height C		D	Spring Deflection Per Spring		Maximum Load at 1" (25.4mm) Deflection - 2 Springs		Approx. Wt./100 Pair		
		in.	(mm)		in.	(mm)	Lbs./In.	(kg/mm)	Lbs.	(kN)	Lbs.
B3264-1	3/8"-16	3"	(76.2)	1 ¹¹ / ₁₆ "	(42.8)	30	(0.5)	78	(.34)	100	(45.3)
B3264-5	3/4"-10	4 ⁵ / ₈ "	(117.5)	2 ⁵ / ₁₆ "	(58.7)	707	(12.6)	1500	(6.67)	400	(181.4)
B3264-6	1"-8	4 ⁷ / ₈ "	(123.8)	3 ¹ / ₄ "	(82.5)	1600	(28.6)	3200	(14.23)	700	(317.5)

All dimensions in charts and on drawings are in inches. Dimensions shown in parentheses are in millimeters unless otherwise specified.

Pipe Rollers & Roller Supports

B3114R Long Pattern Pipe Roller Only

Size Range: 2" (50mm) thru 30" (750mm) pipe

Material: Cast Iron
(Non-metallic polyurethane rollers are available)

Function: Designed for supporting pipe runs with longitudinal movement. Use with steel axle rod.

Finish: Plain

Order By: Part number and finish.

Notes: If using D.I. pipe refer to page 321 for sizing.
Non-metallic roller with stainless steel axle sleeve are available for most sizes (BFP3114R-Pipe Size). Contact Eaton Engineering for more information.

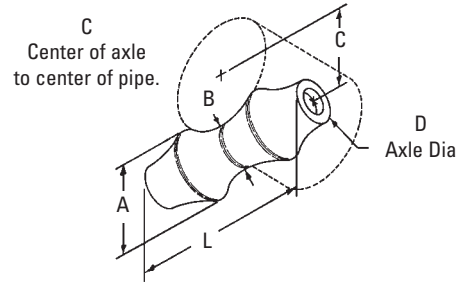

Part No.	Pipe Size in. (mm)	A		B		C		Axle Dia. D		L		Approx. Wt./100	
		in.	(mm)	in.	(mm)	in.	(mm)	in.	(mm)	in.	(mm)	Lbs.	(kg)
B3114R-2	2" (50)	1 ¹ / ₁₆ "	(27.0)	3 ³ / ₄ "	(19.0)	1 ⁹ / ₁₆ "	(39.7)	3 ³ / ₈ "	(9.5)	2 ⁵ / ₈ "	(66.7)	29	(13.1)
B3114R-2 ¹ / ₂	2 ¹ / ₂ " (65)	1 ¹ / ₄ "	(31.7)	7 ⁷ / ₈ "	(22.2)	1 ⁷ / ₈ "	(47.6)	1 ¹ / ₂ "	(12.7)	3 ¹ / ₈ "	(79.4)	47	(21.3)
B3114R-3	3" (80)	1 ³ / ₈ "	(34.9)	7 ⁷ / ₈ "	(22.2)	2 ³ / ₁₆ "	(55.6)	1 ¹ / ₂ "	(12.7)	3 ³ / ₄ "	(95.2)	62	(28.1)
B3114R-3 ¹ / ₂	3 ¹ / ₂ " (90)	1 ¹ / ₂ "	(38.1)	1"	(25.4)	2 ¹ / ₂ "	(63.5)	1 ¹ / ₂ "	(12.7)	4 ¹ / ₄ "	(107.9)	71	(32.2)
B3114R-4	4" (100)	1 ¹⁹ / ₃₂ "	(40.5)	1"	(25.4)	2 ³ / ₄ "	(69.8)	1 ¹ / ₂ "	(12.7)	4 ³ / ₄ "	(120.6)	96	(43.5)
B3114R-5	5" (125)	1 ⁷ / ₈ "	(47.6)	1 ¹ / ₈ "	(28.6)	3 ³ / ₈ "	(85.7)	5 ⁵ / ₈ "	(15.9)	5 ¹³ / ₁₆ "	(147.6)	131	(59.4)
B3114R-6	6" (150)	2 ¹ / ₈ "	(54.0)	1 ¹ / ₄ "	(31.7)	3 ¹⁵ / ₁₆ "	(100.0)	3 ³ / ₄ "	(19.0)	6 ⁷ / ₈ "	(174.6)	207	(93.9)
B3114R-8	8" (200)	2 ⁵ / ₈ "	(66.7)	1 ¹ / ₂ "	(38.1)	5 ¹ / ₁₆ "	(128.6)	7 ⁷ / ₈ "	(22.2)	8 ⁷ / ₈ "	(225.4)	323	(146.5)
B3114R-10	10" (250)	3 ³ / ₁₆ "	(81.0)	1 ³ / ₄ "	(44.4)	6 ¹ / ₄ "	(158.7)	7 ⁷ / ₈ "	(22.2)	11"	(279.4)	482	(218.6)
B3114R-12	12" (300)	3 ³ / ₄ "	(95.2)	2"	(50.8)	7 ³ / ₈ "	(187.3)	1"	(25.4)	13"	(330.2)	854	(387.4)
B3114R-14	14" (350)	4 ³ / ₈ "	(111.1)	2 ¹ / ₂ "	(63.5)	8 ¹ / ₄ "	(209.5)	1 ¹ / ₈ "	(28.6)	14 ¹ / ₄ "	(361.9)	1150	(521.6)
B3114R-16	16" (400)	4 ⁵ / ₈ "	(117.5)	2 ¹ / ₂ "	(63.5)	9 ¹ / ₄ "	(234.9)	1 ¹ / ₄ "	(31.7)	16 ¹ / ₄ "	(412.7)	1200	(544.3)
B3114R-18	18" (450)	5 ¹ / ₈ "	(130.2)	2 ³ / ₄ "	(69.8)	10 ³ / ₈ "	(263.5)	1 ¹ / ₄ "	(31.7)	18 ¹ / ₄ "	(463.5)	1550	(703.1)
B3114R-20	20" (500)	5 ⁵ / ₈ "	(142.9)	3"	(76.2)	11 ¹ / ₂ "	(292.1)	1 ³ / ₈ "	(34.9)	20 ¹ / ₄ "	(514.3)	2080	(943.5)
B3114R-24	24" (600)	6 ³ / ₄ "	(171.4)	3 ⁵ / ₈ "	(92.1)	13 ¹³ / ₁₆ "	(350.8)	1 ¹ / ₂ "	(38.1)	24 ¹ / ₄ "	(615.9)	3300	(1496.9)
B3114R-30	30" (750)	8 ¹ / ₂ "	(215.9)	4 ¹ / ₂ "	(114.3)	17 ¹ / ₄ "	(438.1)	1 ³ / ₄ "	(44.4)	30 ¹ / ₄ "	(768.3)	6200	(2812.3)

All dimensions in charts and on drawings are in inches. Dimensions shown in parentheses are in millimeters unless otherwise specified.

B3117R - Short Pattern Pipe Roller Only

Size Range: 2" (50mm) thru 42" (1050mm) pipe

Material: Cast Iron
(Non-metallic polyurethane rollers are available)

Function: Designed for supporting pipe runs with longitudinal movement. Use with steel axle rod.

Finish: Plain

Order By: Part number and finish.

Notes: If using D.I. pipe refer to page 321 for sizing. Non-metallic roller with stainless steel axle sleeve are available for most sizes (BFP3117R-Pipe Size). Contact Eaton Engineering for more information.

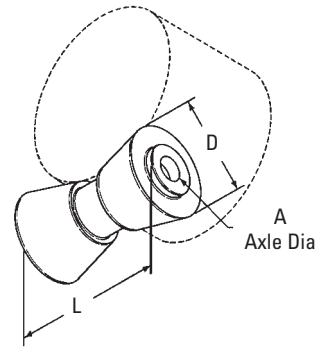

Part No.	Pipe Size		Axle Dia. A		D		L		Approx. Wt./100	
	in.	(mm)	in.	(mm)	in.	(mm)	in.	(mm)	Lbs.	(kg)
B3117R-2 to 3 1/2	2" to 3 1/2"	(50 to 90)	1/2"	(12.7)	1 7/8"	(47.6)	2 3/4"	(69.8)	70	(31.7)
B3117R-4 to 6	4" to 6"	(100 to 150)	1/2"	(12.7)	2 1/16"	(52.4)	3 3/4"	(95.2)	114	(51.7)
B3117R-8 to 10	8", 10"	(200 to 250)	3/4"	(19.0)	3 1/4"	(82.5)	6"	(152.4)	329	(149.2)
B3117R-12 to 14	12", 14"	(300 to 350)	7/8"	(22.2)	4"	(101.6)	8"	(203.2)	600	(272.1)
B3117R-16 to 20	16" to 20"	(400 to 500)	1 1/8"	(28.6)	4 1/2"	(114.3)	9"	(228.6)	781	(354.2)
B3117R-24	24"	(600)	1 1/4"	(31.7)	4 7/16"	(112.7)	10"	(254.0)	842	(381.9)
B3117R-30	30"	(750)	1 3/4"	(44.4)	5 1/2"	(139.7)	12 1/2"	(317.5)	1385	(628.2)
B3117R-36 to 42	36" to 42"	(900 to 1050)	2"	(50.8)	6"	(152.4)	14 7/8"	(377.8)	1585	(718.9)

All dimensions in charts and on drawings are in inches. Dimensions shown in parentheses are in millimeters unless otherwise specified.