

# Beam Clamps



Beam clamps offered in this section are designed to provide attachment of hanger rods to structural members without drilling or welding. A wide range of types and sizes are available for various applications.

## Materials

Carbon Steel, Malleable Iron and Forged Steel are used in the manufacturing of beam clamps and accessories. Stainless steel and other materials are available.

## Finishes

The standard finishes for mechanical supports are plain steel (oil coated) sometimes referred to as black and Electro-Galvanized Zinc (ASTM B633 SC3). Hot-Dip Galvanized After Fabrication (ASTM A123), Red Primer, Plastic Coating and DURA GREEN™. Other special coatings are available upon request.

Note: Due to the design of some products, (threads, connecting hardware, swivels, etc.) items may or may not be uniformly coated with special finishes. In some cases, the hanger itself may be coated, however, the hardware may be supplied Electro-Plated, copper plated, or in stainless steel.

Recommended Set screw Torque (unless otherwise specified)

|                 |                 |                   |                   |                   |
|-----------------|-----------------|-------------------|-------------------|-------------------|
| 1/4"-20         | 3/8"-16         | 1/2"-13           | 5/8"-11           | 3/4"-10           |
| 4 ft/lbs (5 Nm) | 5 ft/lbs (7 Nm) | 11 ft/lbs (15 Nm) | 21 ft/lbs (28 Nm) | 34 ft/lbs (46 Nm) |

Over torqued set screws will damage beam clamps in this section.

We are aware that torque wrenches are not used or not available in many instances. In the absence of a torque wrench, the set screw should be finger tightened to the I-beam and then an additional 1/4 to 1/2 turn applied to the set screw.

## Approvals (as noted)

Items in this section are Underwriters Laboratories Listed, Factory Mutual Approved, and comply with Federal Specification WW-H-171E & A-A-1192A or Manufacturers Standardization Society ANSI/MSS SP-69 & SP-58.

## B351L - Steel C-Clamp With Locknut

**Size Range:** 3/8"-16 thru 7/8"-9 rod

**Material:** Steel

**Function:** For attachment to I-beams, channels, and wide flange beams where the thickness does not exceed 3/4" (19.0mm). Hardened set screw secures "C" Clamp to beam.

**Approvals:** B351L (3/8"-16 thru 3/4"-10), is Underwriters Laboratories Listed in the USA (UL) and Canada (cUL). Conforms to Federal Specification WW-H-171E & A-A-1192A, Type 23 and Manufacturers Standardization Society ANSI/MSS SP-69 & SP-58, Type 23.

**Finish:** Plain. Contact customer service for alternative finishes and materials.

**Note:** When retaining strap is required, order B3362 thru B3365 separately. See page 30.

**Order By:** Part number and finish

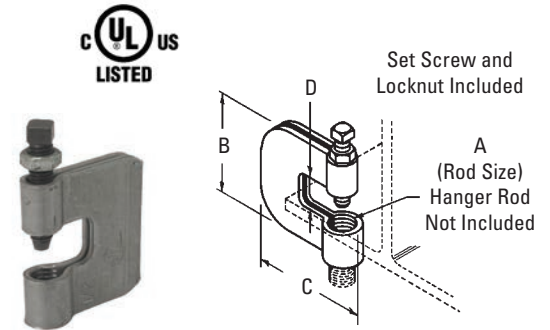

| Part No.  | Rod Size A | B      |        | C      |        | D    |        | Design Load |        | Maximum Iron Pipe Size Per UL |       | Approx. Wt./100 |        |
|-----------|------------|--------|--------|--------|--------|------|--------|-------------|--------|-------------------------------|-------|-----------------|--------|
|           |            | in.    | (mm)   | in.    | (mm)   | in.  | (mm)   | Lbs.        | (kN)   | in.                           | (mm)  | Lbs.            | (kg)   |
| B351L-3/8 | 3/8"-16    | 2 3/8" | (60.3) | 2 3/8" | (60.3) | 3/4" | (19.0) | 300         | (0.89) | 4"                            | (100) | 41              | (18.6) |
| B351L-1/2 | 1/2"-13    | 2 3/8" | (60.3) | 2 3/8" | (60.3) | 3/4" | (19.0) | 380         | (1.69) | 6"                            | (150) | 41              | (18.6) |
| B351L-5/8 | 5/8"-11    | 2 3/8" | (60.3) | 2 1/4" | (57.1) | 3/4" | (19.0) | 550         | (2.44) | 6"                            | (150) | 60              | (27.2) |
| B351L-3/4 | 3/4"-10    | 2 3/8" | (60.3) | 2 1/4" | (57.1) | 3/4" | (19.0) | 630         | (2.80) | 6"                            | (150) | 71              | (32.2) |
| B351L-7/8 | 7/8"-9     | 3"     | (76.2) | 3 1/4" | (82.5) | 1"   | (25.4) | 1200        | (5.34) | --                            | --    | 184             | (83.4) |

**Note:** See page 28 for recommended setscrew torque.

## B3036L - Malleable Iron C-Clamp With Locknut

**Size Range:** 3/8"-16 thru 3/4"-10 rod

**Material:** Malleable Iron

**Function:** Designed for attaching a hanger rod to the flange of a beam.

**Approvals:** B3036L is Underwriters Laboratories Listed in the USA (UL) and Canada (cUL). Complies with Federal Specification WW-H-171E & A-A-1192A Type 23 and Manufacturers Standardization Society ANSI/MSS SP-69 & SP-58 Type 23.

**Finish:** Plain or Electro-Galvanized

**Order By:** Part number and finish. When retaining strap is required, order B3362 thru B3365 separately. See page 30.

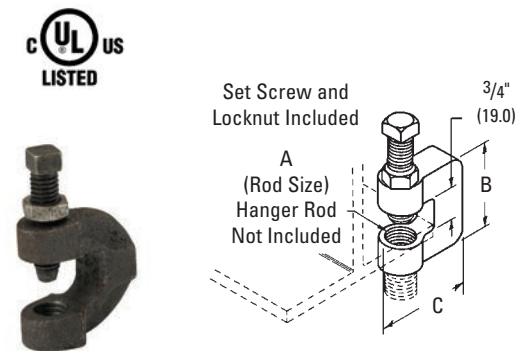

| Part No.   | Rod Size A | B      |        | C      |        | Design Load |        | Maximum Iron Pipe Size Per UL |       | Approx. Wt./100 |        |
|------------|------------|--------|--------|--------|--------|-------------|--------|-------------------------------|-------|-----------------|--------|
|            |            | in.    | (mm)   | in.    | (mm)   | Lbs.        | (kN)   | in.                           | (mm)  | Lbs.            | (kg)   |
| B3036L-3/8 | 3/8"-16    | 1 3/4" | (44.4) | 1 3/4" | (44.4) | 300         | (0.89) | 4"                            | (100) | 41              | (18.6) |
| B3036L-1/2 | 1/2"-13    | 1 3/4" | (44.4) | 1 3/4" | (44.4) | 380         | (1.69) | 5"                            | (125) | 41              | (18.6) |
| B3036L-5/8 | 5/8"-11    | 2"     | (50.8) | 1 7/8" | (47.6) | 530         | (2.36) | 6"                            | (150) | 60              | (27.2) |
| B3036L-3/4 | 3/4"-10    | 2"     | (50.8) | 2"     | (50.8) | 530         | (2.36) | 6"                            | (150) | 71              | (32.2) |

**Note:** See page 28 for recommended setscrew torque.

All dimensions in charts and on drawings are in inches. Dimensions shown in parentheses are in millimeters unless otherwise specified.

# Beam Clamps

## B3362, B3363, B3364, B3365 - Retaining Strap

**Size Range:** 6" (152.4mm) to 12" (304.8mm) lengths

**Material:** Steel (Stainless Steel available)

**Finish:** Pre-Galvanized

**Function:** Designed for use with B351L and B3036L C-Clamps.

**Order By:** Part number, length 'L', (add 1" (25.4) minimum to flange width), and finish.

**Note:** Requires field forming on beam.

| Flange Width |           | Length L    |
|--------------|-----------|-------------|
| in.          | (mm)      | in. (mm)    |
| 3"-5"        | (76-127)  | 6" (152.4)  |
| 5"-7"        | (127-178) | 8" (203.2)  |
| 7"-9"        | (178-228) | 10" (254.0) |
| 9"-11"       | (228-279) | 12" (304.8) |

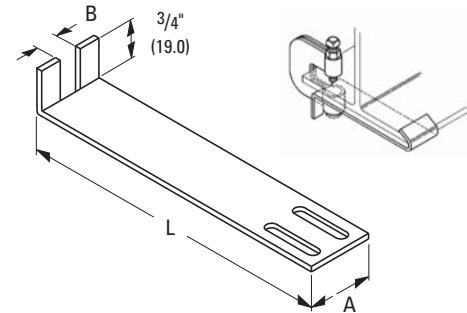

Material Thickness  
12 Gauge (2.7)



| Part No. | For Use With  | A      |        | B       |        | Approx. Wt./100 for Length 'L' of |                         |                          |                          |
|----------|---|--------|--------|---------|--------|-----------------------------------|-------------------------|--------------------------|--------------------------|
|          |   | in.    | (mm)   | in.     | (mm)   | 6" (152.4)<br>Lbs. (kg)           | 8" (203.2)<br>Lbs. (kg) | 10" (254.0)<br>Lbs. (kg) | 12" (304.8)<br>Lbs. (kg) |
| B3362-L  | B351L- <sup>3</sup> / <sub>8</sub> & 1/2  | 1 1/4" | (31.7) | 7/16"   | (11.1) | 27 (12.2)                         | 35 (15.9)               | 44 (19.9)                | 52 (23.6)                |
| B3363-L  | B351L- <sup>5</sup> / <sub>8</sub> & <sup>3</sup> / <sub>4</sub> ,<br>B3036L- <sup>3</sup> / <sub>8</sub> & 1/2 | 1 1/4" | (31.7) | 5/8"    | (15.9) | 26 (11.8)                         | 35 (15.9)               | 43 (19.5)                | 52 (23.6)                |
| B3364-L  | B3036L- <sup>5</sup> / <sub>8</sub> & <sup>3</sup> / <sub>4</sub>   | 1 1/4" | (31.7) | 1 1/16" | (17.4) | 26 (11.8)                         | 35 (15.9)               | 43 (19.5)                | 52 (23.6)                |
| B3365-L  | B351L- <sup>7</sup> / <sub>8</sub>  | 1 1/2" | (38.1) | 3/4"    | (19.0) | 32 (14.5)                         | 42 (19.0)               | 52 (23.6)                | 62 (28.1)                |

Beam Clamps

## B3037Z - Z-Purlin Malleable C-Clamp

**Material:** Malleable Iron

**Function:** Designed for attaching a <sup>3</sup>/<sub>8</sub>"-16 hanger rod to the bottom flange of a Z-purlin.

**Approvals:** Underwriters Laboratories Listed in the USA (UL) and Canada (cUL) for up to 4" (100mm) pipe. Conforms to Federal Specification WW-H-171E & A-A-1192A, Type 23 and Manufacturers Standardization Society ANSI/MSS SP-69 & SP-58, Type 23.

**Finish:** Plain or Electro-Galvanized

**Order By:** Part number and finish.

**Weight:** Approx. Wt./100 90 Lbs. (40.8kg)

**Design Load:** 400 Lbs. (1.78kN)

**Note:** See page 28 for recommended setscrew torque.

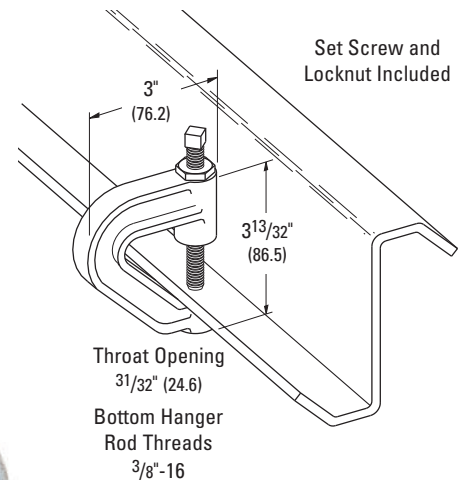

## B3031-3/8 - Light Duty Malleable C-Clamp

**Material:** Malleable Iron

**Function:** Designed for attaching a 3/8"-16 hanger rod to the top or bottom flange of a beam or bar joist when setscrew is in the down position as shown.

**Approvals:** Underwriters Laboratories Listed in the USA (**UL**) and Canada (**cUL**) for up to 4" pipe. Conforms to Federal Specification WW-H-171E & A-A-1192A, Type 19 and Manufacturers Standardization Society ANSI/MSS SP-69 & SP-58, Type 19.

**Finish:** Plain or Electro-Galvanized

**Order By:** Part number and finish. When retaining strap is required, order Fig. 69 separately. See Page 37.

**Weight:** Approx. Wt./100 25 Lbs. (11.3kg)

**Design Load:** 350 Lbs. (1.55kN)

**Note:** See page 28 for recommended setscrew torque.

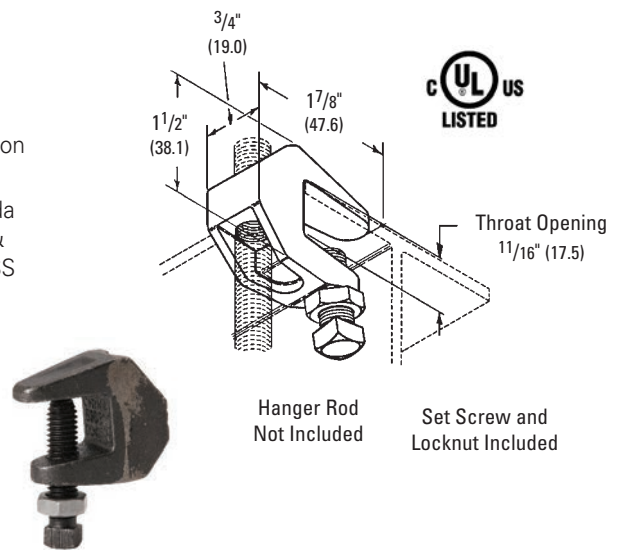

## B3033 - Wide Jaw Reversible C-Clamp

**Size Range:** 3/8"-16 thru 3/4"-10 rod

**Material:** Cast Malleable Steel with hardened cup point set screw and jam nut

**Function:** For attachment to structural shapes requiring wider throat especially under roof with bar joist construction. This clamp may be used with the set screw in the up or down position.

**Approvals:** Underwriters Laboratories Listed in the USA (**UL**) and Canada (**cUL**), and Factory Mutual Engineering Approved (**FM**). Conforms to Federal Specification WW-H-171E Type 19 & A-A-1192A, Type 19 & 23 and Manufacturers Standardization Society ANSI/MSS SP-69 & SP-58, Type 19 & 23.

**Finish:** Plain. Contact customer service for alternative finishes and materials.

**Order By:** Part number, rod size and finish

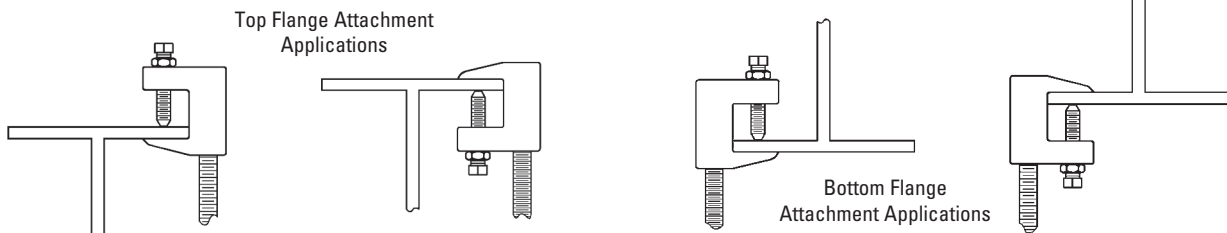
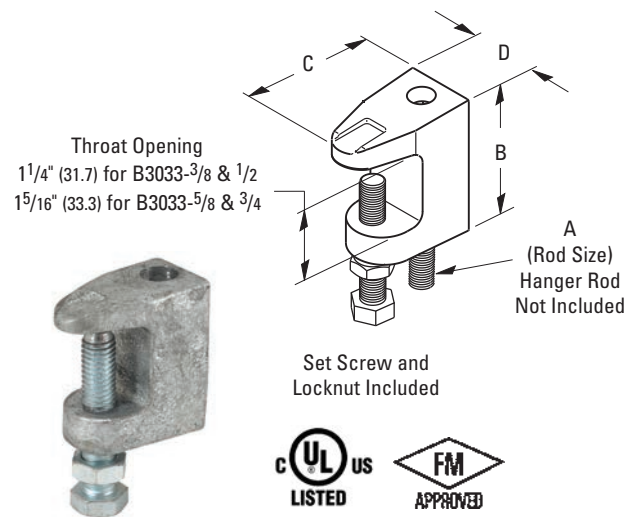

| Part No.  | Rod Size<br>A | B        |        | C       |        | D       |        | Design Load with Setscrew |        | Maximum Iron Pipe Size Per UL |       | Approx. Wt./100<br>Lbs. (kg) |
|-----------|---------------|----------|--------|---------|--------|---------|--------|---------------------------|--------|-------------------------------|-------|------------------------------|
|           |               | in.      | (mm)   | in.     | (mm)   | in.     | (mm)   | Lbs.                      | (kN)   | in.                           | (mm)  |                              |
| B3033-3/8 | 3/8"-16       | 2 1/4"   | (57.1) | 2"      | (50.8) | 1 1/8"  | (28.6) | 500                       | (2.22) | 4"                            | (100) | 54 (24.5)                    |
| B3033-1/2 | 1/2"-13       | 2 5/16"  | (58.7) | 2 3/16" | (55.6) | 1 1/4"  | (31.7) | 810                       | (3.60) | 8"                            | (200) | 51 (23.1)                    |
| B3033-5/8 | 5/8"-11       | 2 5/8"   | (66.7) | 2 1/2"  | (63.5) | 1 3/8"  | (34.9) | 1000                      | (4.45) | 8"                            | (200) | 70 (31.7)                    |
| B3033-3/4 | 3/4"-10       | 2 11/16" | (68.3) | 2 1/2"  | (63.5) | 1 7/16" | (36.5) | 1400                      | (6.23) | 10"                           | (250) | 98 (44.4)                    |

**Note:** See page 28 for recommended setscrew torque.

All dimensions in charts and on drawings are in inches. Dimensions shown in parentheses are in millimeters unless otherwise specified.

# Beam Clamps

## B3034 - C-Clamp

**Size Range:** 3/8"-16 thru 3/4"-10 rod

**Material:** Cast Malleable Steel with hardened cup point set screw and jam nut

**Function:** Recommended for hanging from steel beam where flange thickness does not exceed 3/4" (19.0mm).

**Features:** May be used on top or bottom flange of the beam. Beveled lip allows hanging from top flange where clearance is limited. may be installed with the set screw in the up or down position. Offset design permits unlimited rod adjustment by allowing the rod to be threaded completely through the clamp. The rear window design permits inspection of thread engagement.

**Approvals:** Underwriters Laboratories Listed in the USA (UL) and Canada (cUL), and Factory Mutual Engineering Approved (FM) for 3/8"-16 and 1/2"-13 rod sizes. Conforms to Federal Specification WW-H-171E & A-A-1192A, Type 19 & 23 and Manufacturers Standardization Society ANSI/MSS SP-69 & SP-58, Type 19 & 23. 3/8"-16 is (cULus) Listed to support up to 4" (100mm) pipe with the set screw in the down position, up to 3" (75mm) pipe with the set screw in the up position. 1/2"-13 is (cULus) Listed to support up to 8" (200mm) pipe with the set screw in the down position, up to 6" (150mm) pipe with the set screw in the up position.

**Finish:** Plain. Contact customer service for alternative finishes and materials.

**Order By:** Part number and finish

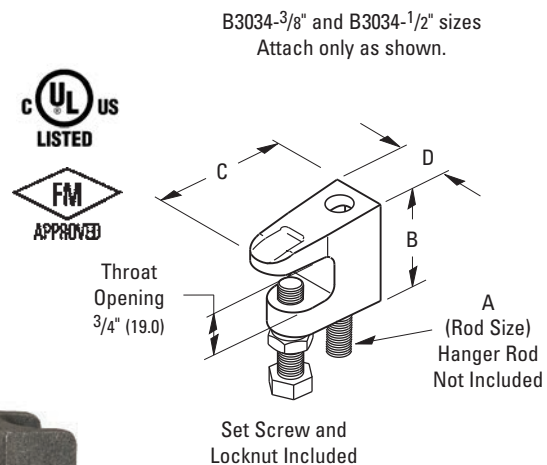

B3034-3/8  
Shown

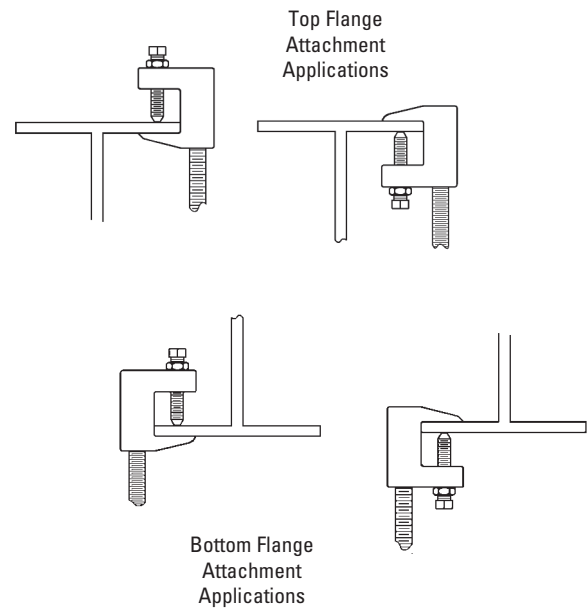

B3034-5/8" and B3034-3/4" sizes  
Attach only as shown.

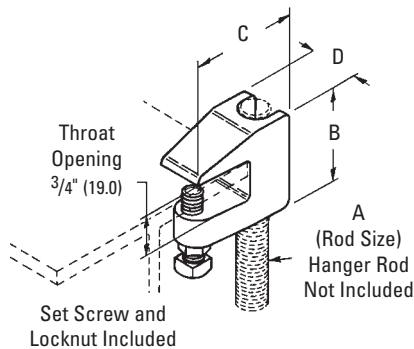

| Part No.  | Rod Size A | B<br>in. (mm)   | C<br>in. (mm)  | D<br>in. (mm)  | Design Load with Setscrew |        | Maximum Iron Pipe Size Per UL |       | Approx. Wt./100 |        |
|-----------|------------|-----------------|----------------|----------------|---------------------------|--------|-------------------------------|-------|-----------------|--------|
|           |            |                 |                |                | Lbs.                      | (kN)   | in.                           | (mm)  | Lbs.            | (kg)   |
| B3034-3/8 | 3/8"-16    | 1 5/8" (41.3)   | 2" (50.8)      | 7/8" (19.0)    | 560                       | (2.49) | 4"                            | (100) | 30              | (13.6) |
| B3034-1/2 | 1/2"-13    | 1 13/16" (46.0) | 2 3/16" (55.6) | 1 3/16" (30.2) | 810                       | (3.60) | 8"                            | (200) | 47              | (21.3) |
| B3034-5/8 | 5/8"-11    | 1 3/4" (44.5)   | 2 1/8" (54.0)  | 1 1/4" (31.7)  | 1000                      | (4.45) | --                            | --    | 58              | (26.3) |
| B3034-3/4 | 3/4"-10    | 2" (50.8)       | 2 1/4" (57.2)  | 1 1/4" (31.7)  | 1500                      | (6.67) | --                            | --    | 77              | (35.0) |

**Note:** See page 28 for recommended setscrew torque.

All dimensions in charts and on drawings are in inches. Dimensions shown in parentheses are in millimeters unless otherwise specified.

## TOLCO™ Fig. 65 - Reversible Steel C-Type Beam Clamp 3/4" (19.0mm) Throat Opening

**Size Range:** 1/2"-13 and 5/8"-11 rod sizes

**Material:** Steel with hardened cup point set screw and jam nut

**Function:** Recommended for hanging from steel beam where flange thickness does not exceed 3/4" (19.0mm).

**Features:** All steel construction eliminates structural deficiencies associated with casting type beam clamps. May be used on top or bottom flange of beam. (Beveled lip allows hanging from top flange where clearance is limited.) May be installed with set screw in up or down position. Offset design permits unlimited rod adjustment by allowing the rod to be threaded completely through the clamp. Open design permits inspection of thread engagement.

**Approvals:** Underwriters Laboratories Listed in the USA (UL) and Canada (cUL). Exceeds requirements of the National Fire Protection Association (NFPA), pamphlet 13, 3/8"-16 rod will support 1/2" (15mm) thru 4" (100mm) pipe  
1/2"-13 rod will support 1/2" (15mm) thru 8" (200mm) pipe  
Included in the Seismic Restraints Catalog approved by the State of California Office of Statewide Health Planning and Development (OSHPD). For additional load spacing and placement information relating OSHPD projects, please refer to the Seismic Restraint System Guidelines.

**Finish:** Plain. Contact customer service for alternative finishes and materials.

**Order By:** Part number and finish

Fig. 65 Patent #4,570,885

Component of State of California OSHPD Approved Seismic Restraints System

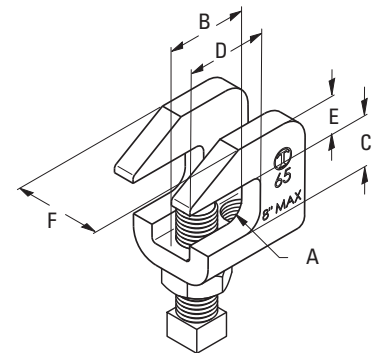

Set Screw and Locknut Included



| Part No. | Rod Size | B      |        | C    |        | D   |        | E     |        |
|----------|----------|--------|--------|------|--------|-----|--------|-------|--------|
|          | A        | in.    | (mm)   | in.  | (mm)   | in. | (mm)   | in.   | (mm)   |
| 65-1/2   | 1/2"-13  | 1 1/2" | (38.1) | 3/4" | (19.0) | 1"  | (25.4) | 9/16" | (14.3) |
| 65-5/8   | 5/8"-11  | 1 1/2" | (38.1) | 3/4" | (19.0) | 1"  | (25.4) | 9/16" | (14.3) |

| Part No. | F             | Max. Rec. Load * | Approx. Wt./100 |
|----------|---------------|------------------|-----------------|
|          | in. (mm)      |                  |                 |
| 65-1/2   | 1 1/4" (31.7) | 1130 (5.02)      | 55 (24.9)       |
| 65-5/8   | 1 1/4" (31.7) | 1130 (5.02)      | 55 (24.9)       |

\* Maximum loads for clamp with set screw in up or down position.

**Note:** See page 28 for recommended setscrew torque.

Beam Clamps

## TOLCO™ Fig. 65XT - Reversible Steel C-Type Beam Clamp 3/4" (19.0mm) Throat Opening

**Size Range:** 3/8"-16 rod size

**Feature:** Extruded holes allow for more thread engagement of threaded rod and set screw.

**Weight:** Approx. Wt./100 - 28.0 Lbs. (12.7kg)

**Design Load:** 730 Lbs (3.25kN)

**Finish:** Plain or Electro-Galvanized

**Order By:** Part number and finish

**Approvals:** Underwriters Laboratories Listed in the USA (UL) and Canada (cUL), and Factory Mutual Engineering Approved (FM) for up to 4" (100mm) pipe.

**Note:** See page 28 for recommended setscrew torque.

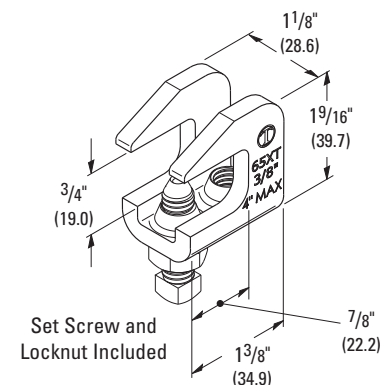
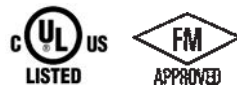

Set Screw and Locknut Included

All dimensions in charts and on drawings are in inches. Dimensions shown in parentheses are in millimeters unless otherwise specified.

# Beam Clamps

## TOLCO™ Fig. 66 - Reversible Steel C-Type Beam Clamp 1 1/4" (31.7mm) Throat Opening

**Size Range:** 3/8"-16, 1/2"-13 rod sizes, and 5/8"-11 rod sizes

**Material:** Steel with hardened cup point set screw and jam nut

**Function:** Recommended for hanging from steel beam where flange thickness does not exceed 1 1/4" (31.7mm).

**Features:** All steel construction eliminates structural deficiencies associated with casting type beam clamps. May be used on top or bottom flange of beam. (Beveled lip allows hanging from top flange where clearance is limited.) May be installed with set screw in up or down position. Offset design permits unlimited rod adjustment by allowing the rod to be threaded completely through the clamp. Open design permits inspection of thread engagement.

**Approvals:** Underwriters Laboratories Listed in the USA (UL) and Canada (cUL). Exceeds requirements of the National Fire Protection Association (NFPA), pamphlet 13, 3/8"-16 rod will support 1/2" (15mm) thru 4" (100mm) pipe  
1/2"-13 rod will support 1/2" (15mm) thru 8" (200mm) pipe  
Included in the Seismic Restraints Catalog approved by the State of California Office of Statewide Health Planning and Development (OSHPD). For additional load spacing and placement information relating OSHPD projects, please refer to the Seismic Restraint System Guidelines.

**Finish:** Plain. Contact customer service for alternative finishes and materials.

**Order By:** Part number and finish

Component of State of California OSHPD Approved Seismic Restraints System

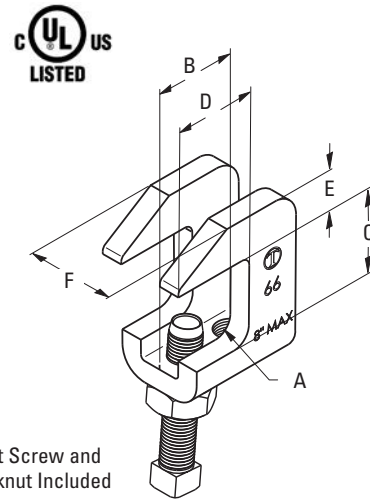

| Part No. | Rod Size A | B       |        | C      |        | D   |        | E     |        |
|----------|------------|---------|--------|--------|--------|-----|--------|-------|--------|
|          |            | in.     | (mm)   | in.    | (mm)   | in. | (mm)   | in.   | (mm)   |
| 66-3/8   | 3/8"-16    | 1 3/16" | (30.2) | 1 1/4" | (31.7) | 1"  | (25.4) | 7/16" | (11.1) |
| 66-1/2   | 1/2"-13    | 1 1/2"  | (38.1) | 1 1/4" | (31.7) | 1"  | (25.4) | 9/16" | (14.3) |
| 66-5/8   | 5/8"-11    | 1 1/2"  | (38.1) | 1 1/4" | (31.7) | 1"  | (25.4) | 9/16" | (14.3) |

| Part No. | F      |        | Max. Rec. Load * |        | Approx. Wt./100 |        |
|----------|--------|--------|------------------|--------|-----------------|--------|
|          | in.    | (mm)   | lbs.             | (kN)   | lbs.            | (kg)   |
| 66-3/8   | 1"     | (25.4) | 610              | (2.71) | 28              | (12.7) |
| 66-1/2   | 1 1/4" | (31.7) | 1130             | (5.02) | 55              | (24.9) |
| 66-5/8   | 1 1/4" | (31.7) | 1130             | (5.02) | 55              | (24.9) |

\* Maximum loads for clamp with set screw in up or down position.

**Note:** See page 28 for recommended setscrew torque.

## TOLCO™ Fig. 67SS - Stainless Steel Reversible C-Type Beam Clamp 3/4" (19.0mm) Throat Opening TOLCO™ Fig. 68SS - Stainless Steel Reversible C-Type Beam Clamp Wide Mouth

**Size Range:** 3/8"-16 and 1/2"-13 rod sizes

**Material:** Stainless Steel (Type 316 or 304)

**Function:** Recommended for hanging from steel beams where flange thickness does not exceed 3/4" (19.0mm) for Fig. 67SS or 1 1/4" (31.7mm) for Fig. 68SS.

**Features:** All steel construction eliminates structural deficiencies associated with casting type beam clamps. May be used on top or bottom flange of beam. May be installed with set screw in up or down position. Offset design permits unlimited rod adjustment by allowing the rod to be threaded completely through the clamp.

**Approvals:** Underwriters Laboratories Listed in the USA (UL) and Canada (cUL). Conforms to Manufacturers Standardization Society ANSI/MSS SP-69 & SP-58, Type 19. Meets or exceeds requirements of the National Fire Protection Association (NFPA), pamphlet 13.

3/8"-16 rod will support 1/2" (15mm) thru 4" (100mm) pipe

1/2"-13 rod will support 1/2" (15mm) thru 8" (200mm) pipe

**Order By:** Part number and stainless steel type.

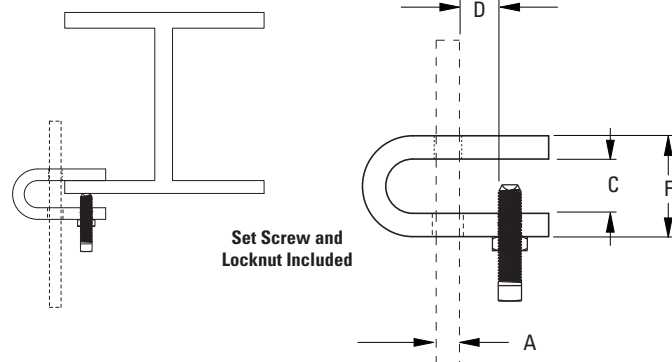
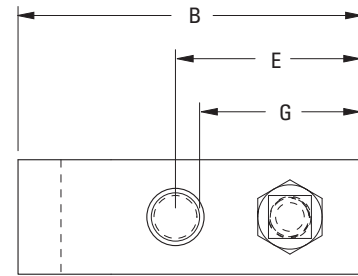

**Fig. 67SS**

| Part No. | Rod Size A | Pipe Size in. (mm)   | B in. (mm) | C in. (mm)  | D in. (mm) | E in. (mm)   |
|----------|------------|----------------------|------------|-------------|------------|--------------|
| 67SS-3/8 | 3/8"-16    | 1/2" - 4" (15 - 100) | 3" (76.2)  | 7/8" (22.2) | 1" (25.4)  | 15/8" (41.3) |
| 67SS-1/2 | 1/2"-13    | 5" - 8" (125 - 200)  | 3" (76.2)  | 7/8" (22.2) | 1" (25.4)  | 15/8" (41.3) |

| Part No. | F in. (mm)   | G in. (mm)    | Test Load lbs. (kN) | Approx. Wt./100 lbs. (kg) |
|----------|--------------|---------------|---------------------|---------------------------|
| 67SS-3/8 | 15/8" (41.3) | 1 1/8" (28.6) | 1500 (6.67)         | 84 (38.1)                 |
| 67SS-1/2 | 15/8" (41.3) | 1 1/8" (28.6) | 4050 (18.01)        | 170 (77.1)                |



**Fig. 68SS \***

| Part No. | Rod Size A | Pipe Size in. (mm)   | B in. (mm)     | C in. (mm)    | D in. (mm)    | E in. (mm)    |
|----------|------------|----------------------|----------------|---------------|---------------|---------------|
| 68SS-3/8 | 3/8"-16    | 1/2" - 4" (15 - 100) | 2 1/16" (52.4) | 1 1/8" (28.6) | 3/4" (19.0)   | 1 1/4" (31.7) |
| 68SS-1/2 | 1/2"-13    | 5" - 8" (125 - 200)  | 2 1/4" (57.1)  | 1 1/4" (31.7) | 13/16" (20.6) | 1 1/4" (31.7) |

| Part No. | F in. (mm)    | Test Load lbs. (kN) | Approx. Wt./100 lbs. (kg) |
|----------|---------------|---------------------|---------------------------|
| 68SS-3/8 | 2" (50.8)     | 1500 (6.67)         | 84 (38.1)                 |
| 68SS-1/2 | 2 1/4" (57.1) | 4050 (18.01)        | 170 (77.1)                |



\* Fig. 68SS minimum order quantity of 30 pieces.

**Note:** See page 28 for recommended setscrew torque.

All dimensions in charts and on drawings are in inches. Dimensions shown in parentheses are in millimeters unless otherwise specified.



# Beam Clamps

## B303-B309 - Beam Clamp

**Size Range:** 1/4"-20 thru 5/8"-11 rod

**Material:** Steel

**Function:** Designed for attaching a hanger rod to the flange of a beam.

**Approvals:** Conforms to Federal Specification WW-H-171E & A-A-1192A, Type 19 and Manufacturers Standardization Society ANSI/MSS SP-69 & SP-58, Type 19.

**Finish:** Electro-Galvanized or Hot-Dip Galvanized

**Order By:** Part number and finish. When retaining strap is required, order B312 separately. See page 39.

**Recommended Set Screw Torque:**

3/8"-16 = 150 in-lbs (16.9 N•m)

1/2"-13 = 350 in-lbs (39.5 N•m)

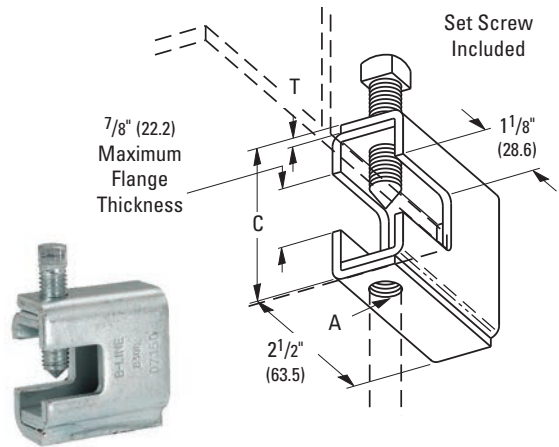

| Part No. | Rod Size A | Setscrew Size | C                                |        | T      |       | Design Load Lbs. (kN) | Approx. Wt./100 Lbs. (kg) |
|----------|------------|---------------|----------------------------------|--------|--------|-------|-----------------------|---------------------------|
|          |            |               | in.                              | (mm)   | in.    | (mm)  |                       |                           |
| B303     | 1/4"-20    | 3/8"-16       | 2 <sup>5</sup> / <sub>16</sub> " | (58.7) | 11 Ga. | (3.0) | 400 (1.78)            | 72 (32.6)                 |
| B304     | 5/16"-18   | 3/8"-16       | 2 <sup>5</sup> / <sub>16</sub> " | (58.7) | 11 Ga. | (3.0) | 600 (2.67)            | 72 (32.6)                 |
| B305     | 3/8"-16    | 3/8"-16       | 2 <sup>5</sup> / <sub>16</sub> " | (58.7) | 11 Ga. | (3.0) | 600 (2.67)            | 72 (32.6)                 |
| B306     | 3/8"-16    | 1/2"-13       | 2 <sup>7</sup> / <sub>16</sub> " | (61.9) | 7 Ga.  | (4.5) | 1100 (4.89)           | 97 (44.0)                 |
| B307     | 1/2"-13    | 1/2"-13       | 2 <sup>7</sup> / <sub>16</sub> " | (61.9) | 7 Ga.  | (4.5) | 1100 (4.89)           | 97 (44.0)                 |
| B308     | 1/2"-13    | 1/2"-13       | 2 <sup>9</sup> / <sub>16</sub> " | (65.1) | 1/4"   | (6.3) | 1500 (6.67)           | 133 (60.3)                |
| B309     | 5/8"-11    | 1/2"-13       | 2 <sup>9</sup> / <sub>16</sub> " | (65.1) | 1/4"   | (6.3) | 1500 (6.67)           | 133 (60.3)                |

Beam Clamps

## Fig. B321 - Series Beam Clamp

**Size Range:** 3/8"-16 thru 3/4"-10 rod

**Material:** Steel

**Function:** Designed for attaching a hanger rod to the flange of a beam.

**Approvals:** Conforms to Federal Specification WW-H-171E & A-A-1192A, Type 19 and Manufacturers Standardization Society ANSI/MSS SP-69 & SP-58, Type 19.

**Finish:** Electro-Galvanized or Hot-Dip Galvanized

**Ordering:** Part number and finish. When retaining strap is required, order B312 separately. See page 39.

**Recommended Set Screw Torque:**

1/2"-13 = 350 in-lbs (39.5 N•m)

5/8"-11 = 700 in-lbs (79.0 N•m)

**Minimum Flange Thickness:**

For B321-1 thru B321-3 = 3/8" (9.5)

For B321-4 & B321-5 = 5/8" (15.9)

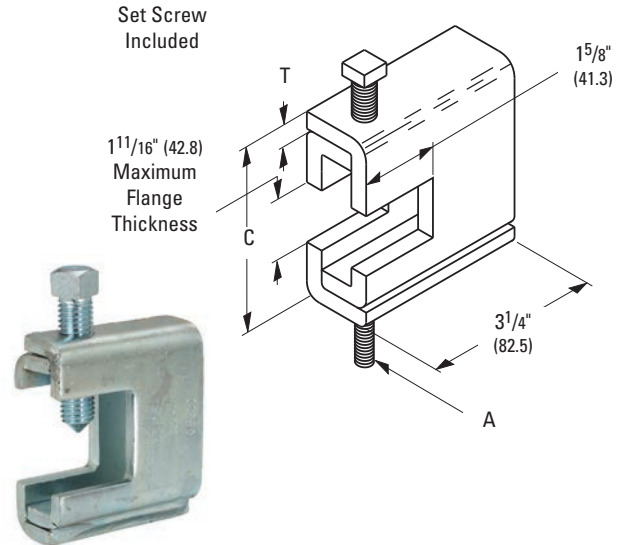

| Part No. | Rod Size A | Setscrew Size | C                                 |        | T     |       | Design Load Lbs. (kN) | Approx. Wt./100 Lbs. (kg) |
|----------|------------|---------------|-----------------------------------|--------|-------|-------|-----------------------|---------------------------|
|          |            |               | in.                               | (mm)   | in.   | (mm)  |                       |                           |
| B321-1   | 3/8"-16    | 1/2"-13       | 3 <sup>9</sup> / <sub>16</sub> "  | (92.1) | 1/4"  | (6.3) | 1300 (5.78)           | 187 (84.8)                |
| B321-2   | 1/2"-13    | 1/2"-13       | 3 <sup>9</sup> / <sub>16</sub> "  | (92.1) | 1/4"  | (6.3) | 1400 (6.23)           | 186 (84.3)                |
| B321-3   | 5/8"-11    | 1/2"-13       | 3 <sup>9</sup> / <sub>16</sub> "  | (92.1) | 1/4"  | (6.3) | 1600 (7.12)           | 185 (83.9)                |
| B321-4   | 5/8"-11    | 5/8"-11       | 3 <sup>23</sup> / <sub>32</sub> " | (94.4) | 5/16" | (7.9) | 1800 (8.00)           | 239 (108.4)               |
| B321-5   | 3/4"-10    | 5/8"-11       | 3 <sup>23</sup> / <sub>32</sub> " | (94.4) | 5/16" | (7.9) | 2000 (8.89)           | 238 (107.9)               |

All dimensions in charts and on drawings are in inches. Dimensions shown in parentheses are in millimeters unless otherwise specified.

## TOLCO™ Fig. 69 - Beam Clamp Retaining Strap

**Size Range:** 3/8"-16 thru 3/4"-10 rod  
 4" (101.6mm) thru 16" (406.4mm) lengths  
 Note: longer lengths are available consult factory

**Material:** Pre-Galvanized Steel

**Function:** To offer more secure fastening of various types of beam clamps to beam where danger of movement might be expected. NFPA 13 requires the use of retaining straps with all beam clamps installed in earthquake areas. Satisfies requirements of NFPA 13.

**Important Note:** Good installation practice of a retaining strap requires that the strap be held tightly and securely to all component parts of the assembly. Therefore a locking mechanism of some kind, such as a hex nut or the beveled locking slot of the Fig. 69R will provide a more secure reliable installation.

**Approvals:** Underwriters Laboratories Listed in the USA (UL) and Canada (cUL). Approved for use with any listed beam clamp. Included in the Seismic Restraints Catalog approved by the State of California Office of Statewide Health Planning and Development (OSHPD). For additional load spacing and placement information relating OSHPD projects, please refer to the Seismic Restraint System Guidelines.

**Finish:** Pre-Galvanized

**Order By:** Part number, length (L), and finish.

**Note:** Minimum return on strap is 1" (25.4mm)  
 Lengths over 16" (406mm) are not UL Listed



Component of State of California OSHPD Approved Seismic Restraints System

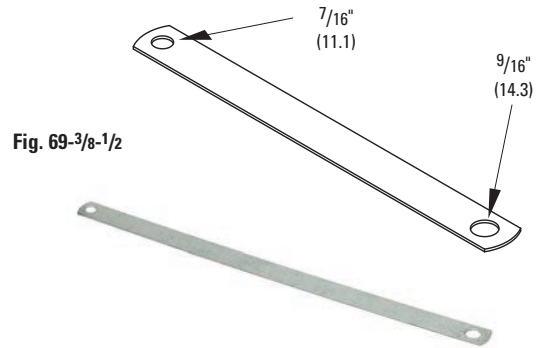

Fig. 69-3/8-1/2

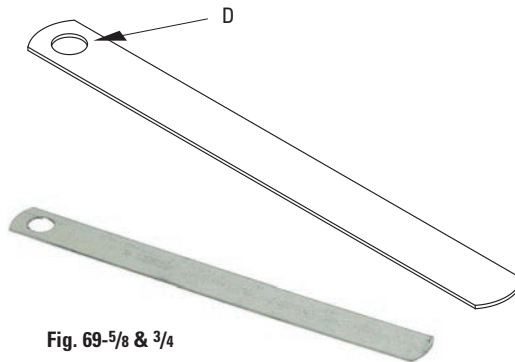
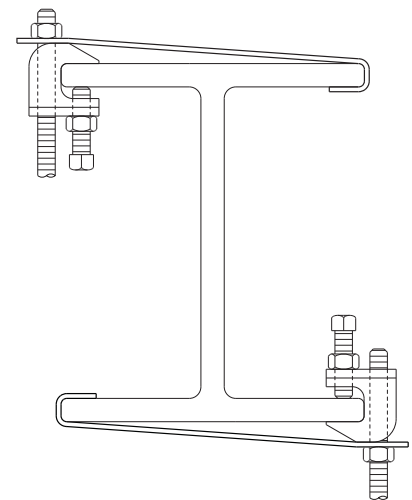

Fig. 69-5/8 & 3/4

| Part No.     | Hole Dia. D |        | For Use With   | Length  |
|--------------|-------------|--------|--|---------|
|              | in.         | (mm)   |  |         |
| 69-3/8-1/2-L | see drawing |        | B3033-3/8, B3034-3/8, B3031-3/8,<br>65-3/8, 65XT-3/8, 66-3/8<br>B3033-1/2, B3034-1/2, 65-1/2, 66-1/2 | Specify |
| 69-5/8-L     | 11/16"      | (17.5) | B3033-5/8, 65-5/8, 66-5/8  | Specify |
| 69-3/4-L     | 13/16"      | (20.6) | B3033-3/4  | Specify |



All dimensions in charts and on drawings are in inches. Dimensions shown in parentheses are in millimeters unless otherwise specified.

# Beam Clamps

## TOLCO™ Fig. 69R - Retrofit Capable Beam Clamp Retaining Strap

**Size Range:** 3/8"-16 & 1/2"-13 rod  
 4" (101.6mm) thru 16" (406.4mm) lengths  
 Note: longer lengths are available consult factory



Component of State of California OSHPD Approved Seismic Restraints System

**Material:** Pre-Galvanized Steel

**Function:** To offer more secure fastening of various types of beam clamps to beam where danger of movement might be expected. NFPA 13 requires the use of retaining straps with all beam clamps installed in earthquake areas. Satisfies requirements of NFPA 13.

**Features:** Beveled locking slot\* is precisely formed to align with the threaded section of a hanger rod or set screw and engage the unit securely. May be used as shown in Section "A-A" or inverted. Allows easy installation for new construction or retrofit applications.

**Important Note:** Good installation practice of a retaining strap requires that the strap be held tightly and securely to all component parts of the assembly. Therefore a locking mechanism of some kind, such as a hex nut or the beveled locking slot of the Fig. 69R will provide a more secure reliable installation.

**Approvals:** Underwriters Laboratories Listed in the USA (**UL**) and Canada (**cUL**). Approved for use with any listed beam clamp. Included in the Seismic Restraints Catalog approved by the State of California Office of Statewide Health Planning and Development (**OSHPD**). For additional load spacing and placement information relating OSHPD projects, please refer to the Seismic Restraint System Guidelines.

**Finish:** Pre-Galvanized

**Order By:** Part number, length, and finish.

**Note:** Minimum return on strap is 1" (25.4mm)

\* Patent #5,947,424

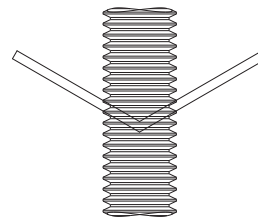
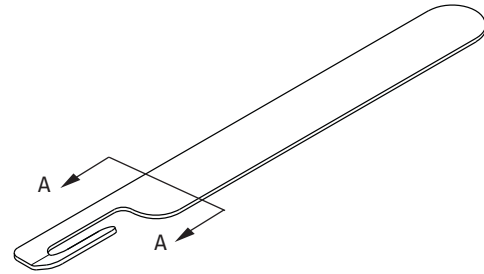

A - A



| Part No.  | Slot Width<br>in. (mm) | For Use With   | Length  |
|-----------|------------------------|--|---------|
| 69R-3/8-L | 7/16" (11.1)           | B3033-3/8, B3034-3/8, B3031-3/8,<br>65-3/8, 65XT-3/8, 66-3/8 | Specify |
| 69R-1/2-L | 9/16" (14.3)           | B3033-1/2, B3034-1/2, 65-1/2, 66-1/2                         | Specify |

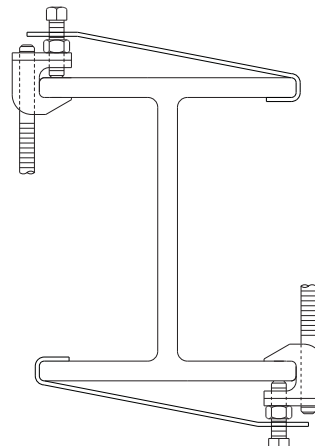
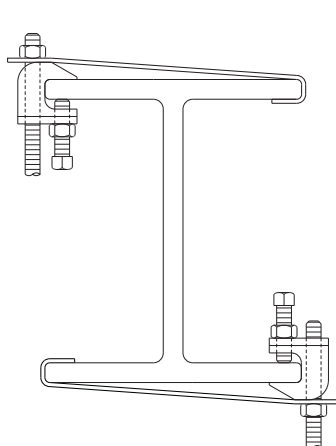

All dimensions in charts and on drawings are in inches. Dimensions shown in parentheses are in millimeters unless otherwise specified.

## B312 - Retaining Strap

**Size Range:** 9" (228.6mm) to 18" (457.2mm) strap lengths

**Material:** Steel

**Function:** Designed for use with B303-B309 and B321 beam clamps.

**Finish:** Pre-Galvanized

**Order By:** Part number and finish.

**Note:**

Maximum beam thickness  $\frac{3}{4}$ " (19.0). For thicker beams step up one flange width size. Requires field forming on beam.

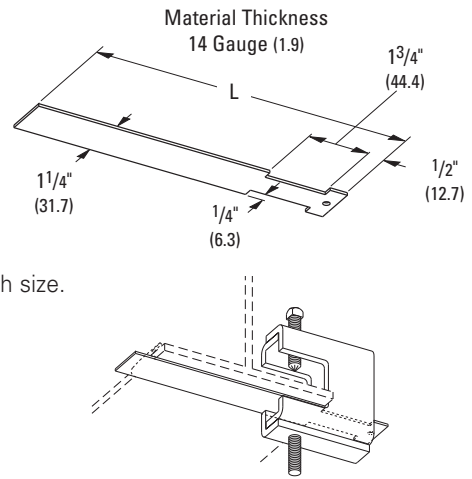

| Part No. | For Flange With |         | L   |         | Approx. Wt./100 |        |
|----------|-----------------|---------|-----|---------|-----------------|--------|
|          | in.             | (mm)    | in. | (mm)    | Lbs.            | kg     |
| B312-6   | 6"              | (152.4) | 9"  | (228.6) | 22              | (10.0) |
| B312-9   | 9"              | (228.6) | 12" | (304.8) | 30              | (13.6) |
| B312-12  | 12"             | (304.8) | 15" | (381.0) | 40              | (18.1) |
| B312-15  | 15"             | (381.0) | 18" | (457.2) | 49              | (22.2) |

## B3040 - Adjustable Beam Clamp

**Size Range:**  $\frac{3}{8}$ "-16 thru  $\frac{3}{4}$ "-10 rod

**Material:** Steel

**Function:** Fits structural I-Beams and wide flange beams, flange widths  $\frac{3}{2}$ " (88.9mm) to 8" (203.2mm), thickness up to  $\frac{1}{2}$ " (12.7mm).

**Approvals:** Conforms to Federal Specification WW-H-171E & A-A-1192A, Type 54, and Manufacturers Standardization Society ANSI/MSS SP-69 & SP-58, Type 27.

**Finish:** Plain. Contact customer service for alternative finishes and materials.

**Order By:** Part number and finish

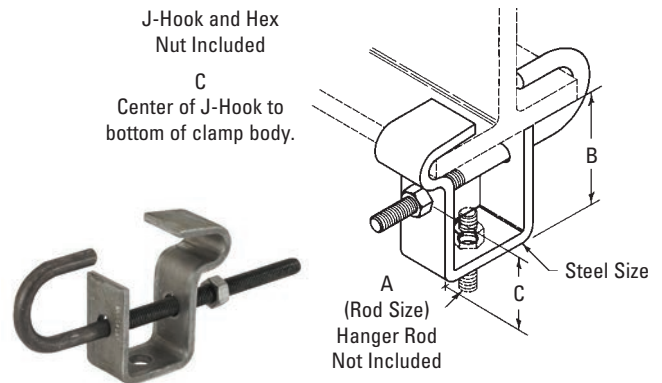

| Part No.  | Rod Size           | B                |        | C                  |        | Steel Size                         |              | Design Load | Approx. Wt./100 |      |         |
|-----------|--------------------|------------------|--------|--------------------|--------|------------------------------------|--------------|-------------|-----------------|------|---------|
|           | A                  | in.              | (mm)   | in.                | (mm)   | in.                                | (mm)         |             | Lbs.            | (kg) |         |
| B3040-3/8 | $\frac{3}{8}$ "-16 | $\frac{23}{4}$ " | (69.8) | $\frac{113}{16}$ " | (46.0) | $\frac{1}{4}$ " x $\frac{11}{4}$ " | (6.3 x 31.7) | 300         | (1.33)          | 120  | (54.4)  |
| B3040-1/2 | $\frac{1}{2}$ "-13 | $\frac{23}{4}$ " | (69.8) | $\frac{13}{4}$ "   | (44.4) | $\frac{1}{4}$ " x $\frac{11}{2}$ " | (6.3 x 38.1) | 700         | (3.11)          | 160  | (72.6)  |
| B3040-5/8 | $\frac{5}{8}$ "-11 | 3"               | (76.2) | $\frac{13}{4}$ "   | (44.4) | $\frac{1}{4}$ " x $\frac{13}{4}$ " | (6.3 x 44.4) | 1000        | (4.45)          | 216  | (98.0)  |
| B3040-3/4 | $\frac{3}{4}$ "-10 | $\frac{33}{8}$ " | (85.7) | $\frac{17}{8}$ "   | (47.6) | $\frac{3}{8}$ " x 2"               | (9.5 x 50.8) | 1800        | (8.00)          | 442  | (200.5) |

All dimensions in charts and on drawings are in inches. Dimensions shown in parentheses are in millimeters unless otherwise specified.

# Beam Clamps

## B3050 - Beam Clamp

**Material:** Steel

**Function:** Recommended for the suspending of hanger rod from the center of an I-beam, equally distributing the load on both sides of the beam. Use with B3210 eye rod, B3211 welded eye rod or B3200 weldless eye nut.

**Approvals:** Conforms to Federal Specification WW-H-171E & A-A-1192A, Type 21 and Manufacturers Standardization Society ANSI/MSS SP-69 & SP-58, Type 21.

**Finish:** Plain. Contact customer service for alternative finishes and materials.

**Order By:** Part number, type, width of flange and finish.

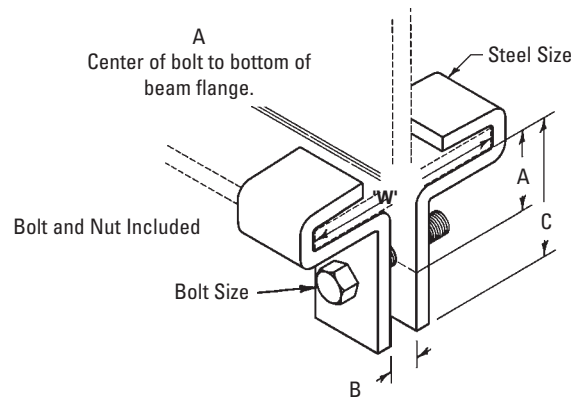

| Part Number & Size | Bolt Size | Flange Thickness |                  | A<br>in. (mm) | B<br>in. (mm) | C<br>in. (mm) | Steel Size                 |             | Design Load<br>Lbs. (kN) |
|--------------------|-----------|------------------|------------------|---------------|---------------|---------------|----------------------------|-------------|--------------------------|
|                    |           | Min.<br>in. (mm) | Max.<br>in. (mm) |               |               |               | in. (mm)                   | (mm)        |                          |
| B3050-2X*          | 1/2"-13   | 3/16" (4.8)      | 1/2" (12.7)      | 1 3/8" (34.9) | 5/8" (15.9)   | 2 1/8" (54.0) | 1/4" x 1 1/4" (6.3 x 31.7) | 1000 (3.11) |                          |
| B3050-5X*          | 3/4"-10   | 5/8" (25.9)      | 1" (25.4)        | 1 7/8" (47.6) | 7/8" (22.2)   | 3" (76.2)     | 1/2" x 2" (12.7 x 50.8)    | 3000 (6.67) |                          |

\* Any flange width shown in bottom chart.

| Flange Width<br>*<br>" (mm) | Approx. Wt./100 For Beam Clamp Size |                |                |
|-----------------------------|-------------------------------------|----------------|----------------|
|                             | 'W'<br>in. (mm)                     | 2<br>lbs. (kg) | 5<br>lbs. (kg) |
| 4                           | 4" (101.6)                          | 116 (52.6)     | 429 (194.6)    |
| 5                           | 5" (127.0)                          | 125 (56.7)     | 458 (207.8)    |
| 6                           | 6" (152.4)                          | 134 (60.8)     | 486 (220.5)    |
| 7                           | 7" (177.8)                          | 143 (64.9)     | 514 (233.2)    |
| 8                           | 8" (203.2)                          | 152 (69.0)     | 543 (246.3)    |
| 9                           | 9" (228.6)                          | 160 (72.6)     | 571 (259.0)    |
| 10                          | 10" (254.0)                         | 169 (76.7)     | 599 (271.8)    |
| 12                          | 12" (304.8)                         | 187 (84.8)     | 656 (297.6)    |



All dimensions in charts and on drawings are in inches. Dimensions shown in parentheses are in millimeters unless otherwise specified.

## B3055 - Steel Beam Clamp

**Size Range:** 3/8"-16 thru 1"-8 rod

**Material:** Steel

**Function:** Designed for attaching a hanger rod to be centered under beam flanges. 2" (50.8mm) vertical adjustment is provided in the clamp.

**Approvals:** Conforms to Federal Specification WW-H-171E & A-A-1192A, Type 21 and Manufacturers Standardization Society ANSI/MSS SP-69 & SP-58, Type 21.

**Finish:** Plain or Electro-Galvanized

**Order By:** Part number, flange width, and finish.

**Note:** Consult factory for additional flange widths.

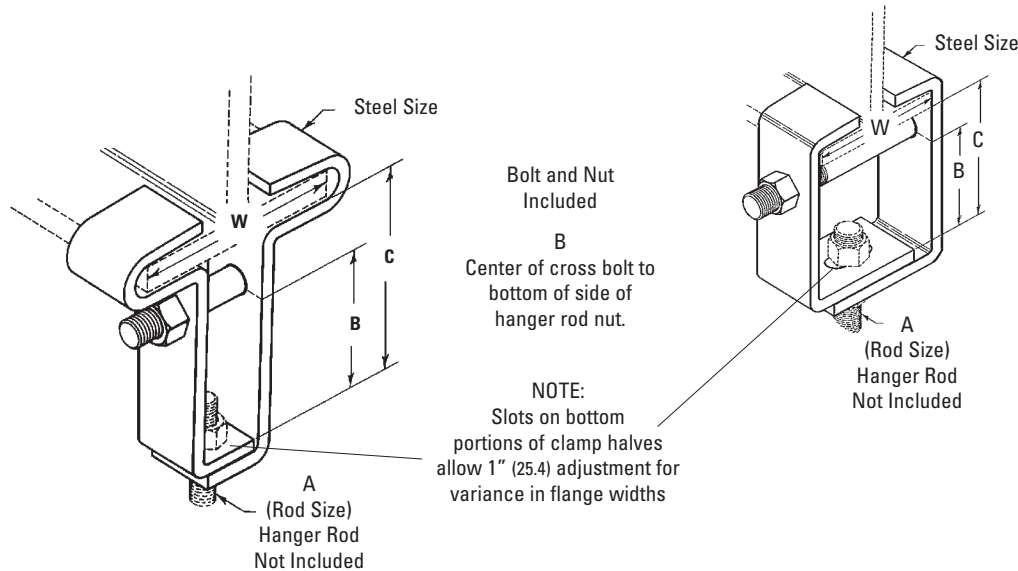

**Note:**  
**Box Style**  
**Furnished For**  
 B3055-3/8 x 4"  
 B3055-1/2 x 4"  
 B3055-5/8 x 4"  
 B3055-3/4 x 4"  
 B3055-7/8 x 4"  
 B3055-1 x 4"  
 B3055-1 x 5"  
 B3055-1 x 6"

| Part No.  | Rod Size |  | B      |        | C      |         | Steel Size    |               | Design Load |         |
|-----------|----------|--|--------|--------|--------|---------|---------------|---------------|-------------|---------|
|           | A        |  | in.    | (mm)   | in.    | (mm)    | in.           | (mm)          | Lbs.        | (kN)    |
| B3055-3/8 | 3/8"-16  |  | 3"     | (76.2) | 4"     | (101.6) | 1/4" x 1 1/4" | (6.3 x 31.7)  | 550         | (2.44)  |
| B3055-1/2 | 1/2"-13  |  | 3"     | (76.2) | 4"     | (101.6) | 1/4" x 1 1/2" | (6.3 x 38.1)  | 850         | (3.78)  |
| B3055-5/8 | 5/8"-11  |  | 3 1/4" | (82.5) | 4 1/2" | (114.3) | 3/8" x 1 1/2" | (9.5 x 38.1)  | 1100        | (4.89)  |
| B3055-3/4 | 3/4"-10  |  | 3 1/4" | (82.5) | 4 1/2" | (114.3) | 3/8" x 2"     | (9.5 x 50.8)  | 1500        | (6.67)  |
| B3055-7/8 | 7/8"-9   |  | 3 1/2" | (88.9) | 5"     | (127.0) | 1/2" x 2"     | (12.7 x 50.8) | 2600        | (11.56) |
| B3055-1   | 1"-8     |  | 3 1/2" | (88.9) | 5 1/2" | (139.7) | 1/2" x 2"     | (12.7 x 50.8) | 4300        | (19.12) |

| Flange Width W |         | Approximate Wt./100 For Beam Clamp Size |             |             |             |             |              | Lbs. (kg) |  |
|----------------|---------|---|-------------|-------------|-------------|-------------|--------------|-----------|--|
| in.            | (mm)    | B3055-3/8"                              | B3055-1/2"  | B3055-5/8"  | B3055-3/4"  | B3055-7/8"  | B3055-1"     |           |  |
| 4"             | (101.6) | 168 (76.2)                              | 201 (91.2)  | 328 (148.8) | 434 (196.8) | 657 (298.0) | 797 (361.5)  |           |  |
| 5"             | (127.0) | 181 (82.1)                              | 217 (98.4)  | 352 (159.6) | 466 (211.4) | 667 (302.5) | 824 (373.7)  |           |  |
| 6"             | (152.4) | 193 (87.5)                              | 231 (104.8) | 373 (169.2) | 495 (224.5) | 705 (319.8) | 877 (397.8)  |           |  |
| 7"             | (177.8) | 205 (93.0)                              | 246 (111.6) | 395 (179.2) | 525 (238.1) | 744 (337.5) | 926 (420.0)  |           |  |
| 8"             | (203.2) | 214 (97.1)                              | 256 (116.1) | 411 (186.4) | 546 (247.6) | 773 (350.6) | 962 (436.3)  |           |  |
| 10"            | (254.0) | 235 (106.6)                             | 282 (127.9) | 449 (203.6) | 596 (270.3) | 840 (381.0) | 1046 (474.4) |           |  |
| 12"            | (304.8) | 259 (117.5)                             | 311 (141.0) | 493 (223.6) | 655 (297.1) | 918 (416.4) | 1143 (518.4) |           |  |

All dimensions in charts and on drawings are in inches. Dimensions shown in parentheses are in millimeters unless otherwise specified.

# Beam Clamps

## B3054 - Malleable Iron Beam Clamp With Extension B3054W0 - Malleable Iron Beam Clamp Without Extension

**Size Range:** 3/8"-16 thru 7/8"-9 rod

**Material:** Malleable Iron

**Function:** Designed for attaching a hanger rod to the bottom flange of a beam. Adjustable for flange widths of 3" (76.2mm) to 7" (177.8mm) and a flange thickness of no greater than 5/8" (15.9mm).

**Approvals:** Underwriters Laboratories Listed. Conforms to Federal Specification WW-H-171E & A-A-1192A, Type 30 and Manufacturers Standardization Society ANSI/MSS SP-69 & SP-58, Type 30.

**Finish:** Plain or Electro-Galvanized

**Ordering:** Part number and finish

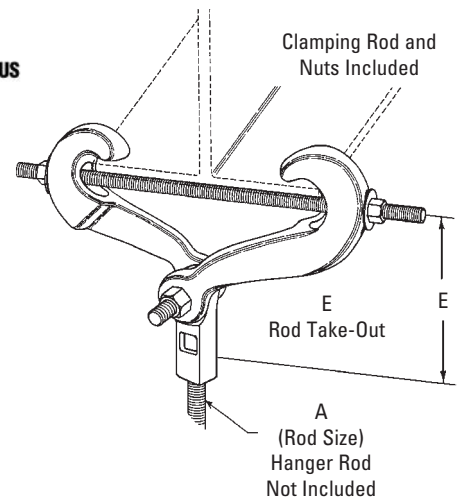

Beam Clamps

| Part No.  | Rod Size<br>A | Rod Take Out 'E' For Beam Flange Width Of in. (mm) |                 |                  |                  |                |
|-----------|---------------|--|-----------------|------------------|------------------|----------------|
|           |               | 3" (76.2)  | 4" (101.6)      | 5" (127.0)       | 6" (152.4)       | 7" (177.8)     |
| B3054-3/8 | 3/8"-16       | 4 11/16" (119.1)                                   | 4 9/16" (115.9) | 4 5/8" (117.5)   | 4" (101.6)       | 3 1/8" (79.4)  |
| B3054-1/2 | 1/2"-13       | 4 13/16" (122.2)                                   | 4 1/2" (114.3)  | 4 5/16" (109.5)  | 3 15/16" (100.0) | 3 1/4" (82.5)  |
| B3054-5/8 | 5/8"-11       | 4 7/8" (123.8)                                     | 4 5/8" (117.5)  | 4 3/8" (111.1)   | 3 3/4" (95.2)    | 3 5/16" (84.1) |
| B3054-3/4 | 3/4"-10       | 5 1/8" (130.2)                                     | 5" (127.0)      | 4 5/8" (117.5)   | 4 1/4" (107.9)   | 3 3/4" (95.2)  |
| B3054-7/8 | 7/8"-9        | 5 3/16" (131.8)                                    | 4 7/8" (123.8)  | 4 11/16" (119.1) | 4 5/16" (109.5)  | 3 3/4" (95.2)  |

| Part No.  | Design Load | Max. Iron Pipe Size Per UL | Approx. Wt./100 |
|-----------|-------------|----------------------------|-----------------|
|           | Lbs. (kN)   | in. (mm)                   | Lbs. (kg)       |
| B3054-3/8 | 730 (3.25)  | 4" (100)                   | 236 (107.0)     |
| B3054-1/2 | 1350 (6.00) | 8" (200)                   | 254 (115.2)     |
| B3054-5/8 | 1365 (6.07) | 10" (250)                  | 260 (117.9)     |
| B3054-3/4 | 1365 (6.07) | 10" (250)                  | 278 (126.1)     |
| B3054-7/8 | 1365 (6.07) | 10" (250)                  | 292 (132.4)     |

All dimensions in charts and on drawings are in inches. Dimensions shown in parentheses are in millimeters unless otherwise specified.

## B3291, B3292, B3293, B3294, B3295, B3296, B3297, B3298

### UFS Beam Clamp With Weldless Eye Nut

Available with left hand threads by adding an L to part number Example: B3291L-\*

**Size Range:** 3/8"-16 thru 2"-4 1/2 rod

**Material:** Forged Steel

**Function:** Designed for attaching a hanger rod to the bottom flange of a beam. Adjustable from flange widths of 3" (76.2mm) to 15" (381.0mm), and flange thickness of no greater than 1 1/32" (26.2mm).

**Approvals:** Complies with Federal Specification WW-H-171E & A-A-1192A (Type 28 without links; Type 29 with links,) and ANSI/MSS SP-58 (Type 28 without links; Type 29 with links).

**Finish:** Plain or Electro-Galvanized

**Order By:** Part number, rod size and finish.

**Note:** Design load for B3291 thru B3295 based on maximum rod size shown. Use the appropriate all threaded rod design load shown on page 322 for sizes less than maximum.

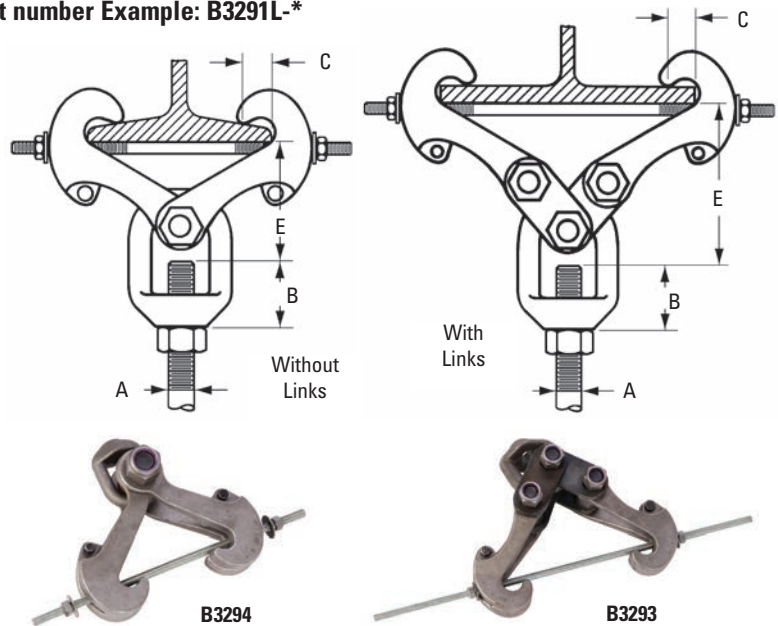

| Part No.<br>*Rod Size | Maximum<br>Beam Flange<br>Thickness |        | Rod Size A<br>(Specify)<br>*                        | B        |         | C      |        | Design Load |         | Approx. Wt./100 |          |
|-----------------------|-------------------------------------|--------|---|----------|---------|--------|--------|-------------|---------|-----------------|----------|
|                       | In.                                 | (mm)   |   | In.      | (mm)    | In.    | (mm)   | Lbs.        | (kN)    | Lbs.            | (kg)     |
| B3291-*               | .60                                 | (15.2) | 3/8"-16, 1/2"-13,<br>5/8"-11, 3/4"-10               | 1 1/4"   | (31.7)  | 1 1/8" | (28.6) | 3230        | (14.36) | 390             | (176.9)  |
| B3292-*               | .60                                 | (15.2) | 7/8"-9, 1"-8  | 1 11/16" | (42.9)  | 1 1/8" | (28.6) | 5900        | (26.24) | 915             | (415.0)  |
| B3293-Δ               | .60                                 | (15.2) | 3/8"-16, 1/2"-13, 5/8"-11,<br>3/4"-10, 7/8"-9, 1"-8 | 1 11/16" | (42.9)  | 1 1/8" | (28.6) | 5900        | (26.24) | 1300            | (589.6)  |
| B3294-*               | 1.031                               | (26.2) | 7/8"-9, 1"-8  | 1 1/2"   | (38.1)  | 1 1/8" | (28.6) | 5900        | (26.24) | 2165            | (982.0)  |
| B3295-Δ               | 1.031                               | (26.2) | 7/8"-9, 1"-8  | 1 1/2"   | (38.1)  | 1 1/8" | (28.6) | 5900        | (26.24) | 3385            | (1535.4) |
| B3296-*               | 1.031                               | (26.2) | 1"-8, 1 1/8"-7,<br>1 1/4"-7, 1 1/2"-6               | 2 1/8"   | (54.0)  | 1 1/8" | (28.6) | 11500       | (51.15) | 2390            | (1084.1) |
| B3297-Δ               | 1.031                               | (26.2) | 1 1/8"-7, 1 1/4"-7, 1 1/2"-6                        | 2 1/8"   | (54.0)  | 1 1/8" | (28.6) | 11500       | (51.15) | 3575            | (1621.6) |
| B3298-*               | 1.031                               | (26.2) | 1 3/4"-5, 2"-4 1/2                                  | 4 9/16"  | (115.9) | 1 1/8" | (28.6) | 11500       | (51.15) | 3675            | (1666.9) |

| Part No. | 'E' Rod Take-Out For Flange Width |          |         |         |          |         |          |          |        |        |        |        |         |
|----------|-----------------------------------|----------|---------|---------|----------|---------|----------|----------|--------|--------|--------|--------|---------|
|          | 3"                                | 4"       | 5"      | 6"      | 7"       | 8"      | 9"       | 10"      | 11"    | 12"    | 13"    | 14"    | 15"     |
| B3291-*  | 4 1/2"                            | 5 5/16"  | 4 1/16" | 3 5/8"  | 2 7/8"   | --      | --       | --       | --     | --     | --     | --     | --      |
| B3292-*  | --                                | 4 3/4"   | 4 7/16" | 4 1/16" | 3 3/8"   | --      | --       | --       | --     | --     | --     | --     | --      |
| B3293-Δ  | --                                | --       | --      | --      | 5 15/16" | 6"      | 5 5/16"  | 5"       | --     | --     | --     | --     | --      |
| B3294-*  | --                                | 6 13/16" | 6 5/8"  | 6 3/8"  | 5 7/8"   | 5 7/8"  | 5 3/8"   | 4 13/16" | --     | --     | --     | --     | --      |
| B3295-Δ  | --                                | --       | --      | --      | --       | --      | --       | --       | 8 1/8" | 7 3/4" | 7 1/8" | 6 5/8" | 6 1/16" |
| B3296-*  | --                                | 7 3/16"  | 7"      | 6 3/4"  | 6 1/4"   | 6 5/16" | 5 13/16" | 5 3/16"  | --     | --     | --     | --     | --      |
| B3297-Δ  | --                                | --       | --      | --      | --       | --      | --       | --       | 8 1/2" | 8 1/8" | 7 1/2" | 7"     | 6 7/16" |
| B3298-*  | --                                | 8 3/8"   | 8 7/16" | 8 3/16" | 7 3/4"   | 7 3/4"  | 7 1/4"   | 6 5/8"   | --     | --     | --     | --     | --      |

To determine (mm) in the above chart, multiply inches by 25.4.

\* Rod Size required to finish part number (see Rod Size 'A' in top chart).

Δ These part numbers are furnished with links.

All dimensions in charts and on drawings are in inches. Dimensions shown in parentheses are in millimeters unless otherwise specified.



# Beam Clamps

## B3042 - Top Beam Hook

**Size Range:** 3/8"-16 and 1/2"-13 rod

**Material:** Steel

**Function:** Designed for attaching hanger rod to the top flange of a beam or angle truss. The support rod completes assembly and secures it to the flange.

**Finish:** Plain or Electro-Galvanized

**Order By:** Part number flange width, flange thickness and finish.

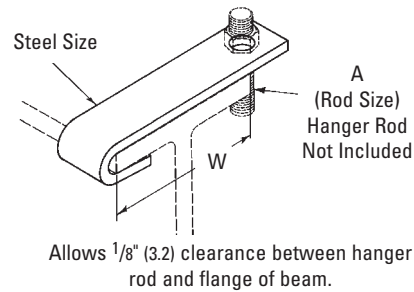

| Part No.  | A       | For Pipe Size |         | Design Load |        |
|-----------|---------|---------------|---------|-------------|--------|
|           |         | in.           | (mm)    | Lbs.        | (kN)   |
| B3042-3/8 | 3/8"-16 | 3/4"-2"       | (20-50) | 300         | (1.33) |
| B3042-1/2 | 1/2"-13 | 2 1/2"-3 1/2" | (65-90) | 500         | (2.22) |

| Part No.  | Approximate Wt./100 Lbs. (kg)<br>For Width of Beam Flange 'W' |        |            |        |            |        |             |        |
|-----------|---|--------|------------|--------|------------|--------|-------------|--------|
|           | 4" (101.6)  |        | 6" (152.4) |        | 8" (203.2) |        | 12" (304.8) |        |
| B3042-3/8 | 47  | (21.3) | 62         | (28.1) | 72         | (32.6) | 108         | (49.0) |
| B3042-1/2 | 65  | (29.5) | 86         | (39.0) | 105        | (47.6) | 146         | (66.2) |

Beam Clamps

## B3045 - Side Beam Clamp

**Size Range:** 3/8"-16 thru 7/8"-9 rods  
3" (76.2mm) thru 9" (228.6mm) flange widths

**Material:** Steel

**Function:** Designed for attaching hanger rod to the side of a beam flange. Works on top or bottom of beam.

**Approvals:** Conforms to Federal Specification WW-H-171E & A-A-1192A, Type 53 and Manufacturers Standardization Society ANSI/MSS SP-69 & SP-58, Type 25.

**Finish:** Plain or Electro-Galvanized

**Order By:** Part number, flange width and thickness, and finish.

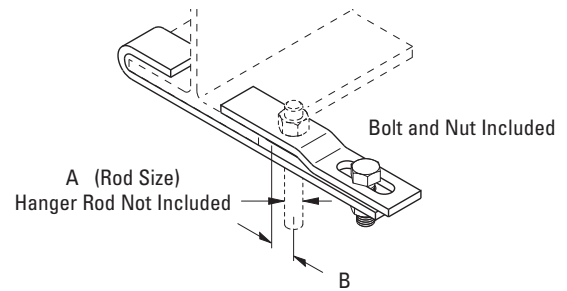

| Part No.  | Rod Size | B       | Flange Width |         | Design Load    |            |
|-----------|----------|---------|--------------|---------|----------------|------------|
|           | A        |         | in.          | (mm)    | Lbs.           | (kN)       |
| B3045-3/8 | 3/8"-16  | 2 1/16" | (52.4)       | 3" - 9" | (76.2 - 228.6) | 300 (1.33) |
| B3045-1/2 | 1/2"-13  | 2 5/16" | (58.7)       | 3" - 9" | (76.2 - 228.6) | 500 (2.22) |
| B3045-5/8 | 5/8"-11  | 2 7/16" | (61.9)       | 3" - 9" | (76.2 - 228.6) | 700 (3.11) |

All dimensions in charts and on drawings are in inches. Dimensions shown in parentheses are in millimeters unless otherwise specified.

## B3042T - Bar Joist Hanger

**Size Range:** 3/8"-16 and 1/2"-13 rod

**Material:** Steel

**Function:** Designed to hook on top chord of metal bar joist. Hanger rod is threaded into product and secured with a washer and nut.

**Approvals:** Underwriters Laboratories Listed in the USA (**UL**) and Canada (**cUL**) for up to 4" (100mm) pipe with 3/8"-16 rod, up to 6" (150mm) pipe with 1/2"-13 rod.

**Finish:** Plain. Contact customer service for alternative finishes and materials.

**Order By:** Part number, width and thickness of bar joist, and finish.

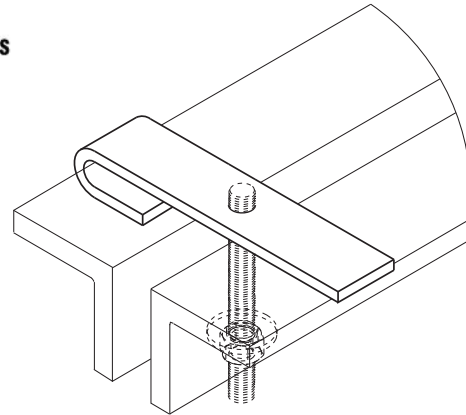

| Part No.   | Rod Size<br>Size | For Pipe Size<br>in. (mm) | Design Load<br>Lbs. (kN) | Approx. Wt./100<br>Lbs. (kg) |
|------------|------------------|---------------------------|--------------------------|------------------------------|
| B3042T-3/8 | 3/8"-16          | Up to 4" (up to 100)      | 300 (1.33)               | 50.6 (22.9)                  |
| B3042T-1/2 | 1/2"-13          | 6" (150)                  | 600 (2.67)               | 50.0 (22.7)                  |

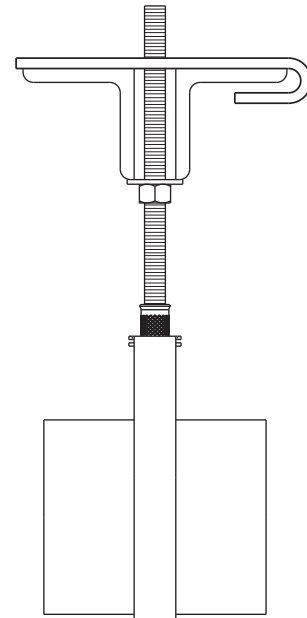
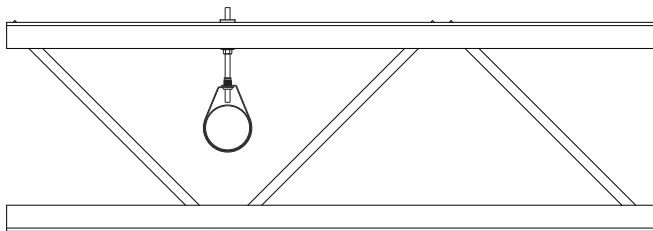

Beam Clamps

All dimensions in charts and on drawings are in inches. Dimensions shown in parentheses are in millimeters unless otherwise specified.

# Beam Clamps

## TOLCO™ Fig. 130 - Trus Joist Beam Clamp

**Size Range:** 130-1 = TJI 230 or equivalent  
 130-2 = TJI S31 or equivalent  
 130-3 = TJI 110 or equivalent  
 130-4 = TJI 560 or equivalent  
 130-5 = TJI 560 or equivalent  
 130-6 = —

**Material:** Steel

**Function:** Designed for attachment to trus joist beams.  
 Use with B3210 Series eye rods.

**Approvals:** Sizes 1 - 6 are Underwriters Laboratories Listed in the USA (**UL**) and Canada (**cUL**) list through 4" (100mm) pipe. All Fig. 130 Beam Clamps meet requirements of Factory Mutual Engineering and NFPA 13, through 4" (100mm) pipe.

**Finish:** Electro-Galvanized or Hot-Dip Galvanized

**Order By:** Part number and finish.



Hardware Included

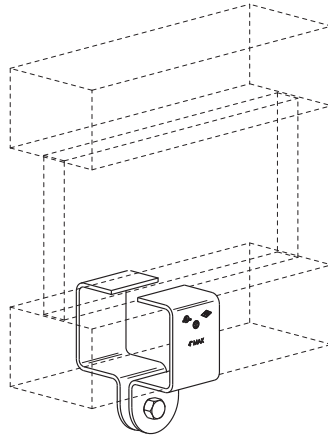
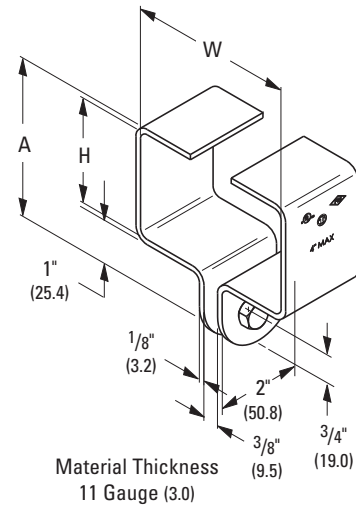

Beam Clamps

| Part No. | Hardware Size | A      |         | H      |        | W       |        | Approx. Wt./100 |        |
|----------|---------------|--------|---------|--------|--------|---------|--------|-----------------|--------|
|          |               | in.    | (mm)    | in.    | (mm)   | in.     | (mm)   | Lbs.            | (kg)   |
| 130-1    | 3/8"-16       | 3 1/4" | (82.5)  | 1 1/2" | (38.1) | 2 5/16" | (58.7) | 65              | (29.5) |
| 130-2    | 3/8"-16       | 3 1/2" | (88.9)  | 1 3/4" | (44.4) | 2 1/2"  | (63.5) | 70              | (31.7) |
| 130-3    | 3/8"-16       | 3 1/4" | (82.5)  | 1 1/2" | (38.1) | 1 3/4"  | (44.4) | 58              | (26.3) |
| 130-4    | 3/8"-16       | 3 1/2" | (88.9)  | 1 1/2" | (38.1) | 3 1/2"  | (88.9) | 83              | (37.6) |
| 130-5†   | 1/2"-13       | 3 5/8" | (92.1)  | 1 3/4" | (44.4) | 3 1/2"  | (88.9) | 86              | (39.0) |
| 130-6†   | 1/2"-13       | 4 1/2" | (114.3) | 2 1/2" | (63.5) | 3 7/8"  | (98.4) | 101             | (45.8) |

'H' and 'W' are beam dimensions.

\* Maximum Recommended Load 500 Lbs. (2.22kN) Safety Factor of 5

† Larger bolts and I-rods are required for 5" (125mm) and 6" (150mm) pipe sizes

