

REDI-RAIL™ - Straight Sections

REDI-RAIL

REDI-RAIL Rung

An "I"-Beam shaped rung provides a great strength-to-weight ratio. Patented fastener hole is designed to provide maximum grip for the fastener threads.



REDI-RAIL Rung Fastener

Specially designed and finished rung fastener. Rung pullout tested to over 3000 lbs. Vibration tested for your confidence.

Multi-Functional Pre-Punched Holes

Act as holes for splice plate hardware: allow for field cutting to any length, no field-drilling necessary. Holes also allow rungs to be repositioned. Holes allow for easy attachment of accessory items requiring 1/4" hardware (or smaller).



Patent Information
U.S. Patent D361982; 5,580,014
Canada 2,137,879
UK Patent 2,285,343
Other United States and foreign patents are pending.



How The Service Advisor Works

We know that your time is important! That's why the color-coding system in this catalog is designed to help you select products that fit your service needs. Products are marked to indicate the typical lead time for orders of 50 pieces or less.

Customer: How do I select my straight sections, covers, or fittings so that I get the quickest turnaround?

Service Advisor: Each part of our selection chart is shown in colors. If any section of a part number is a different color, the part will typically ship with the longer lead time represented by the colors.

- Green = Fastest shipped items
- Black = Normal lead-time items
- Red = Normally long lead-time items

Example: **RSI** **04A** **075KO** **09SL** - **12** - **120**
 ● ● ● ● ● ●

Part will have a normal lead time because of the 075KO knockout type.

RSI04A and RSI05A Straight Sections

Straight Section Part Numbering

Prefix
Example: **RSI 06 A 075KO 09 SL - 12 - 120**

Series	Height	Material	Knockout Type	Bottom Type	Construction	Width	Length
● RSI	● 04 = 4" ● 05 = 5"	A = Aluminum	● Blank = None ● 050KO = 1/2" KO ● 075KO = 3/4" KO ● 100KO = 1" KO	Ladder- ● 06 = 6" rung spacing ● 09 = 9" rung spacing ● 12 = 12" rung spacing Trough- ● VB = Vented Bottom ● SB = Solid Bottom	SL = Straight Ladder	● 06 = 6" ● 09 = 9" ● 12 = 12" ● 18 = 18" ● 24 = 24" ● 30 = 30" ● 36 = 36"	● ① 144 = 12 ft. ● ② 120 = 10 ft.

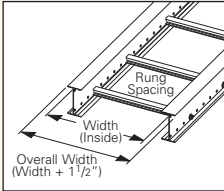

Values are based on simple beam tests per VE-1 on 36" wide cable tray with rungs spaced on 12" centers. The published load safety factor is 1.5. To convert 1.5 safety factor to 2.0, multiply the published load by 0.75. To obtain mid-span deflection, multiply a load by the deflection multiplier. Cable tray must be supported on spans shorter than or equal to the length of the tray. These systems will support without collapse a 200 lb. concentrated load.

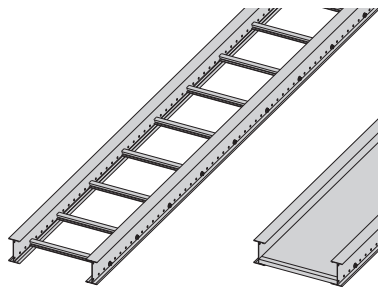

Ladder Type
(Specify Rung Spacing)

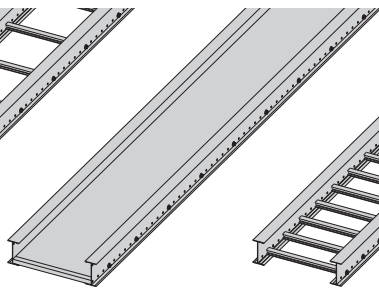

Solid Bottom

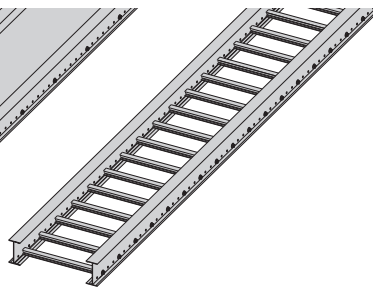

Vented Bottom



REDI-RAIL with knockouts.

- Splices included with straight sections

B-Line Series	Side Rail Dimensions	NEMA, CSA & UL Classifications	Span ft	Load lbs/ft	Deflection Multiplier	Design Factors for Two Rails	Span meters	Load kg/m	Deflection Multiplier	Design Factors for Two Rails
RSI04A		NEMA: 12B CSA: 112kg/m 3.7m UL Cross Sectional Area: 0.40 in ²	6	224	0.0015	Area=0.93 in ² Sx=1.11 in ³ Ix=1.96 in ⁴	1.8	333	0.025	Area=5.99 cm ³ Sx=18.10 cm ³ Ix=81.70 cm ⁴
			8	169	0.0047		2.4	252	0.080	
			10	108	0.0115		3.0	161	0.196	
			12	75	0.0238		3.7	112	0.406	

B-Line Series	Side Rail Dimensions	NEMA, CSA & UL Classifications	Span ft	Load lbs/ft	Deflection Multiplier	Design Factors for Two Rails	Span meters	Load kg/m	Deflection Multiplier	Design Factors for Two Rails
RSI05A		NEMA: 12B CSA: 123kg/m 3.7m UL Cross Sectional Area: 0.60 in ²	6	224	0.0008	Area=1.08 in ² Sx=1.55 in ³ Ix=3.53 in ⁴	1.8	333	0.014	Area=6.95 cm ³ Sx=25.40 cm ³ Ix=147.00 cm ⁴
			8	187	0.0026		2.4	278	0.045	
			10	119	0.0064		3.0	178	0.109	
			12	83	0.0132		3.7	123	0.225	

When cable trays are used in continuous spans, the deflection of the cable tray is reduced by as much as 50%. Design factors: Ix = Moment of Inertia, Sx = Section Modulus.

- Green = Fastest shipped items
- Black = Normal lead-time items
- Red = Normally long lead-time items

RSI06A and RSI07A Straight Sections

Straight Section Part Numbering

Example: **RSI 06 A 075KO 09 SL - 12 - 120**

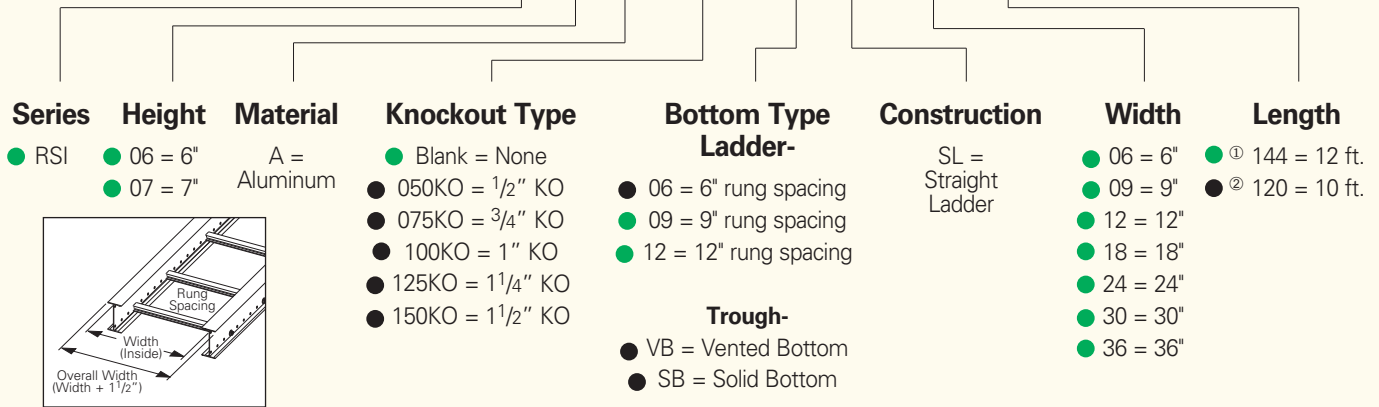

REDI-RAIL

Values are based on simple beam tests per VE-1 on 36" wide cable tray with rungs spaced on 12" centers. The published load safety factor is 1.5. To convert 1.5 safety factor to 2.0, multiply the published load by 0.75. To obtain mid-span deflection, multiply a load by the deflection multiplier. Cable tray must be supported on spans shorter than or equal to the length of the tray. These systems will support without collapse a 200 lb. concentrated load.

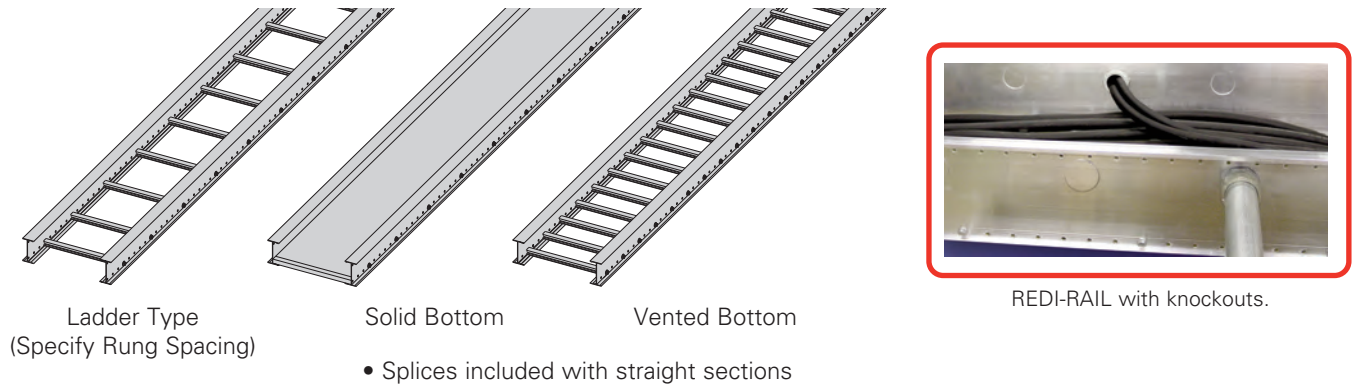

B-Line Series	Side Rail Dimensions	NEMA, CSA & UL Classifications	Span ft	Load lbs/ft	Deflection Multiplier	Design Factors for Two Rails	Span meters	Load kg/m	Deflection Multiplier	Design Factors for Two Rails
RSI06A		NEMA: 12B CSA: 121kg/m 3.7m UL Cross Sectional Area: 0.60 in ²	6	224	0.0005	Area=1.18 in ² Sx=1.98 in ³ Ix=5.51 in ⁴	1.8	333	0.009	Area=7.59 cm ³ Sx=32.50 cm ³ Ix=230.00 cm ⁴
			8	184	0.0017		2.4	273	0.029	
			10	118	0.0041		3.0	175	0.070	
			12	82	0.0085		3.7	121	0.144	

B-Line Series	Side Rail Dimensions	NEMA, CSA & UL Classifications	Span ft	Load lbs/ft	Deflection Multiplier	Design Factors for Two Rails	Span meters	Load kg/m	Deflection Multiplier	Design Factors for Two Rails
RSI07A		NEMA: 12C CSA: 182kg/m 3.7m UL Cross Sectional Area: 0.60 in ²	6	224	0.0003	Area=1.50 in ² Sx=2.69 in ³ Ix=8.79 in ⁴	1.8	333	0.006	Area=9.68 cm ³ Sx=44.10 cm ³ Ix=366.00 cm ⁴
			8	224	0.0010		2.4	333	0.018	
			10	176	0.0026		3.0	262	0.044	
			12	122	0.0053		3.7	182	0.091	

When cable trays are used in continuous spans, the deflection of the cable tray is reduced by as much as 50%. Design factors: Ix = Moment of Inertia, Sx = Section Modulus.

● Green = Fastest shipped items ● Black = Normal lead-time items ● Red = Normally long lead-time items

Standard Splice Plate

- Furnished in pairs with 1/4" hardware.
- UL Classified.
- One pair including hardware provided with each straight section. (Expansion splice quantity subtracted)

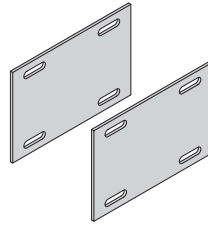

Tray Series	Catalog No.
RSI04A	● R4A-SSP
RSI05A	● R5A-SSP
RSI06A	● R6A-SSP
RSI07A	● R7A-SSP

Expansion Splice Plate

- Furnished in pairs with 1/4" hardware.
- Bonding jumpers required on each side rail.

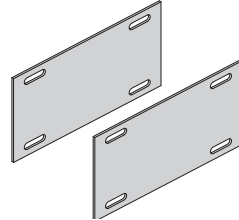

Tray Series	Catalog No.
RSI04A	● R4A-ESP
RSI05A	● R5A-ESP
RSI06A	● R6A-ESP
RSI07A	● R7A-ESP

Step Down Splice Plate

- Furnished in pairs with 1/4" hardware.
- UL Classified.

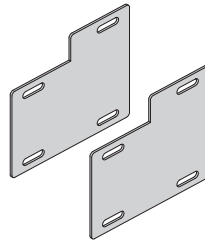

Tray Series	Catalog No.
RSI05A to RSI04A	● RAA-DSP-45
RSI06A to RSI04A	● RAA-DSP-46
RSI07A to RSI04A	● RAA-DSP-47
RSI06A to RSI05A	● RAA-DSP-56
RSI07A to RSI05A	● RAA-DSP-57
RSI07A to RSI06A	● RAA-DSP-67

Vertical Adjustable Splice Plate

- Furnished in pairs with 1/4" hardware.
- UL Classified.
- Bonding jumpers not required.

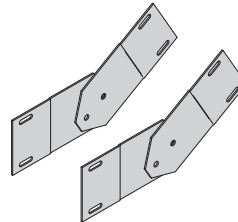

Tray Series	Catalog No.
RSI04A	● R4A-VSP
RSI05A	● R5A-VSP
RSI06A	● R6A-VSP
RSI07A	● R7A-VSP

Requires supports within 24" on both sides, per NEMA VE 2.

FLEX-MOUNT™ Adjustable Splice Plates

- Furnished in pairs with 1/4" hardware.
- Horizontally adjustable to 90°.
- Vertically adjustable to 15°.
- UL Classified.
- For optional rung, see page F-17.

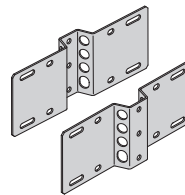

Tray Series	Catalog No.
RSI04A	● R4A-FSP
RSI05A	● R5A-FSP
RSI06A	● R6A-FSP
RSI07A	● R7A-FSP

Requires supports within 24" on both sides, per NEMA VE 2.

Adaptor Splice Plate

- Furnished in pairs with 1/4" hardware.
- Horizontally adjustable to 90°.
- For connecting to old Redi-Rail system.

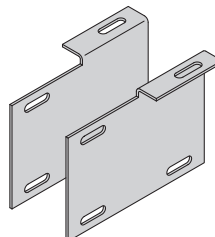

Tray Series	Catalog No.
RSI04A	● R4A-ASP
RSI05A	● R5A-ASP
RSI06A	● R6A-ASP
RSI07A	● R7A-ASP

● Green = Fastest shipped items ● Black = Normal lead-time items ● Red = Normally long lead-time items

All dimensions in parentheses are millimeters unless otherwise specified.

Offset Reducing Splice Plate

- Furnished in pairs with 1/4" hardware.
- UL Classified.

Specify the following:

- † C = center reducer
- S = side reducer

r (tray reduction) 3", 6", 9", 12", 15", 18", 21", 24", 27", or 30"

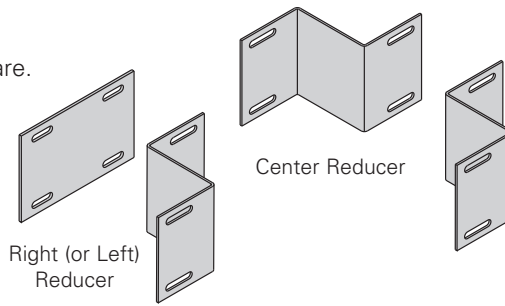

Tray Series	Catalog No.
RSI04A	● R4A-RSP-†
RSI05A	● R5A-RSP-†
RSI06A	● R6A-RSP-†
RSI07A	● R7A-RSP-†

Tray To Box Splice Plates

- Furnished in pairs with 1/4" hardware.
- UL Classified.

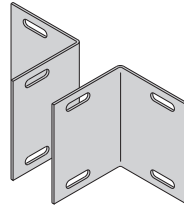

Tray Series	Catalog No.
RSI04A	● R4A-TTB
RSI05A	● R5A-TTB
RSI06A	● R6A-TTB
RSI07A	● R7A-TTB

Frame Type Box Connector

- Furnished with 1/4" hardware for tray connection.

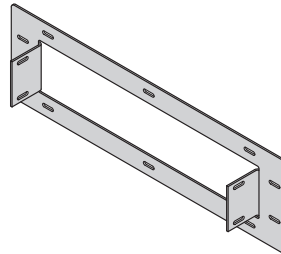

Tray Series	Catalog No.
RSI04A	● R4A-FTB-†
RSI05A	● R5A-FTB-†
RSI06A	● R6A-FTB-†
RSI07A	● R7A-FTB-†

† = tray width

Blind End

- Furnished as one plate with 1/4" hardware.

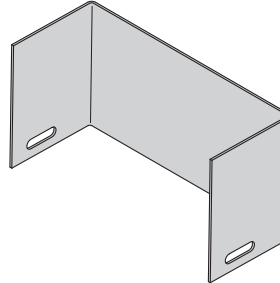

Tray Series	Catalog No.
RSI04A	● R4A-END-†
RSI05A	● R5A-END-†
RSI06A	● R6A-END-†
RSI07A	● R7A-END-†

† = tray width

Drop-Out

- Provides 4" (101mm) radius.
- Holes provided to secure cables.

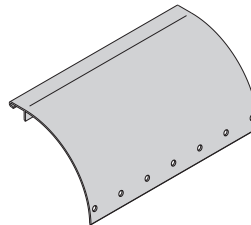

Tray Series	Catalog No.
All	● RAA-OUT-†

† = tray width

Bonding Jumper

- Furnished in pairs with 1/4" hardware.
- UL Classified.
- 14 1/2" (368mm) length.

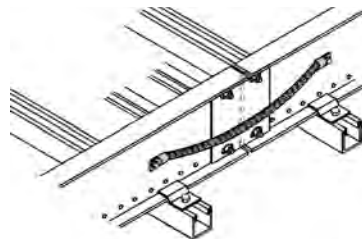

Ampacity	Catalog No.
1200	● 99-30

† = tray width

● Green = Fastest shipped items ● Black = Normal lead-time items ● Red = Normally long lead-time items

All dimensions in parentheses are millimeters unless otherwise specified.

Conduit To Tray Adaptors

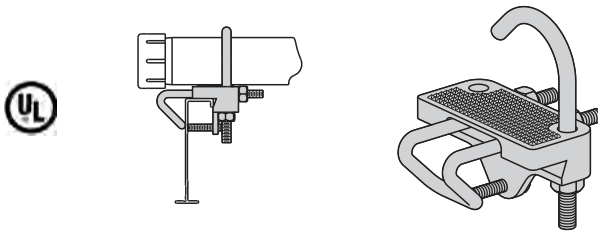

Conduit Size		Catalog No.
in	mm	
1/2, 3/4	(15, 20)	● 9G-1158-1/2, 3/4
1, 1 1/4	(25, 32)	● 9G-1158-1, 1 1/4
1 1/2, 2	(40, 50)	● 9G-1158-1 1/2, 2
2 1/2, 3	(65, 80)	● 9G-1158-2 1/2, 3
3 1/2, 4	(90, 100)	● 9G-1158-3 1/2, 4

Conduit To Tray Adaptors

- Mounting hardware not included.

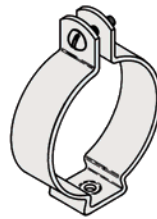

Conduit Size		Catalog No.
in	mm	
1/2	(15)	● BL1400
3/4	(20)	● BL1410
1	(25)	● BL1420
1 1/2	(40)	● BL1430

REDI-RAIL™ Clamp/Guide

- Features a no-twist design.
- Has four times the strength of the traditional design.
- Each side is labeled to ensure proper installation.
- Designed for 1/4" hardware.
- Furnished in pairs with or without hardware.

Patent No.
RE35479

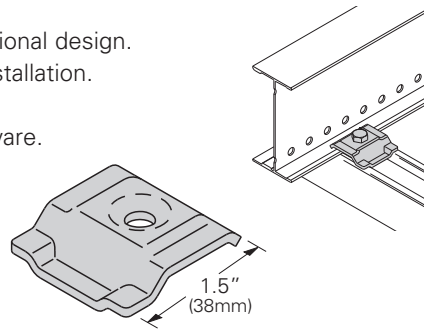

Catalog No.	
● 9ZN-1204	(without hardware)
● 9ZN-1204NB	(with hardware)

Hanger Rod Bracket

- Furnished as pair of studed clamps with 1/4" serrated flanged lock nuts.
- Loading is 1,000 lbs. (4.45kN) per pair with safety factor of 3.
- Position ATR 3" (76mm) wider than cable tray.

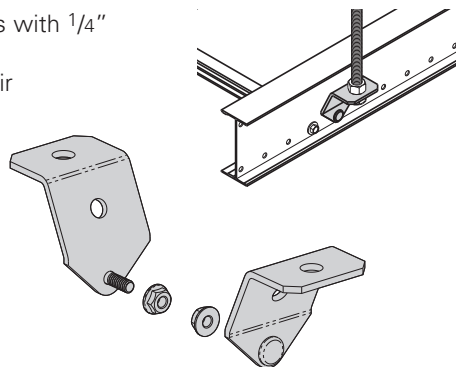

Support ATR Size	Catalog No.
3/8"	● 9(*)-R238
1/2"	● 9(*)-R250

(*) Insert ZN or SS

● Green = Fastest shipped items ● Black = Normal lead-time items ● Red = Normally long lead-time items

All dimensions in parentheses are millimeters unless otherwise specified.

Trapeze Support Kit

Trapeze kits provide the components required for a single trapeze support in one package. These kits are available in pre-galvanized steel with zinc-plated hardware or hot dip galvanized steel with 316 stainless steel hardware.

The SH channel provides the convenience of pre-punched slots, which eliminate the need for field drilling.

The illustrated hardware is sealed in a plastic bag and boxed with the channel, which is pre-cut to the appropriate length as shown in the chart.

Designed for use with 1/2" threaded rod. (order separately)

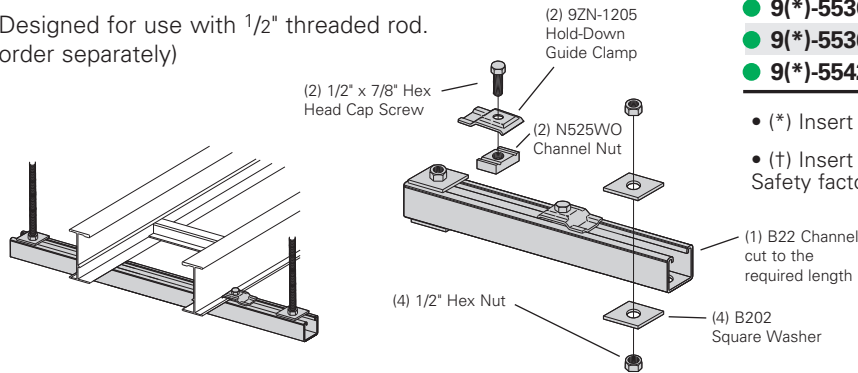

Catalog No.	Tray Width in. (mm)	Channel Length in. (mm)	Uniform Load lbs (kN)
● 9(*)-5506-22SH(+)	6 (152)	16 (406)	1600 (7.11)
● 9(*)-5509-22SH(+)	9 (229)	18 (457)	1250 (5.56)
● 9(*)-5512-22SH(+)	12 (305)	22 (559)	1125 (5.00)
● 9(*)-5518-22SH(+)	18 (457)	28 (711)	865 (3.85)
● 9(*)-5524-22SH(+)	24 (610)	34 (864)	700 (3.11)
● 9(*)-5530-22SH(+)	30 (762)	40 (1016)	590 (2.62)
● 9(*)-5536-22SH(+)	36 (914)	46 (1168)	510 (2.27)
● 9(*)-5542-22SH(+)	42 (1067)	52 (1321)	450 (2.00)

- (*) Insert **P** or **G**
- (+) Insert 3/8 for 3/8" threaded rod hardware. Safety factor of 3.0 on all loads.

Heavy Duty Trapeze Support Kit

Trapeze kits provide the components required for a single trapeze support in one package. These kits are available in Dura Green™ epoxy coated steel with zinc-plated hardware or hot dip galvanized steel with 316 stainless steel hardware.

The SH channel provides the convenience of pre-punched slots, which eliminates the need for field drilling.

The illustrated hardware is sealed in a plastic bag and boxed with the channel, which is pre-cut to the appropriate length as shown in the chart.

Designed for use with 1/2" threaded rod. (order rod separately)

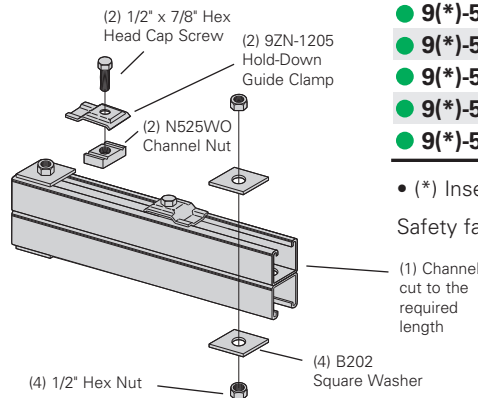

Catalog No.	Tray Width in. (mm)	Channel Length in. (mm)	Uniform Load lbs (kN)
● 9(*)-5506-22SHA	6 (152)	16 (406)	1350 (6.01)
● 9(*)-5509-22SHA	9 (229)	18 (457)	1350 (6.01)
● 9(*)-5512-22SHA	12 (305)	22 (559)	1350 (6.01)
● 9(*)-5518-22SHA	18 (457)	28 (711)	1350 (6.01)
● 9(*)-5524-22SHA	24 (610)	34 (864)	1350 (6.01)
● 9(*)-5530-22SHA	30 (762)	40 (1016)	1350 (6.01)
● 9(*)-5536-22SHA	36 (914)	46 (1168)	1350 (6.01)
● 9(*)-5542-22SHA	42 (1067)	52 (1321)	1350 (6.01)

- (*) Insert **G** or **GRN**
- Safety factor of 3.0 on all loads.

Trapeze Hardware Kit

- Kit sold in plastic bag.

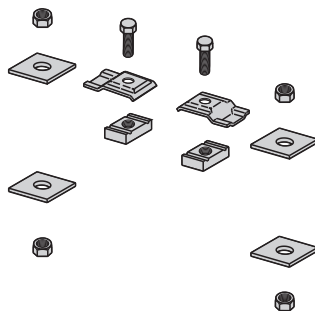

Catalog No.	
● 9ZN-5500-1/2	● 9G-5500-1/2
1 pr. 9ZN-1205	1 pr. 9G-1205
2 HHC Screw 1/2 x 7/8" ZN	2 HHC Screw 1/2 x 7/8" SS6
2 N525 WO ZN	2 N525 WO SS6
4 B202 ZN 1/2" sq washer	4 B202 HDG 1/2" sq washer
4 HN 1/2" ZN	4 HN 1/2" SS6

● Green = Fastest shipped items ● Black = Normal lead-time items ● Red = Normally long lead-time items

All dimensions in parentheses are millimeters unless otherwise specified.

Center Hung Tray Support

- Center Hung Cable Tray Support allows cable to be laid-in from both sides.
- Helps eliminate costly cable pulling and field cutting of cable tray supports. Labor costs can be dramatically reduced.
- Required hardware and threaded rod material for trapeze assemblies are reduced by 50%.
- Designed for use with 1/2" threaded rod. (order separately)
- Use with all aluminum and steel cable trays through 24" (610mm) width.
- Load capacity is 700 lbs. (3.11Kn) per support. Safety factor of 3.0. Eccentric loading is not to exceed a 60% vs. 40% load differential.
- The maximum recommended unsupported span length is 144"/12 ft. (3.66 m).
- Hardware shown is furnished.

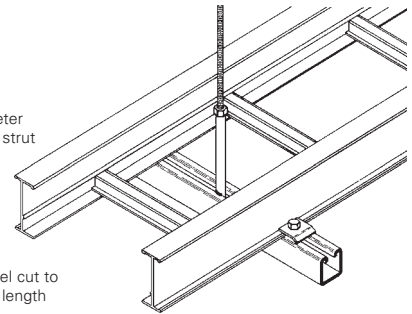
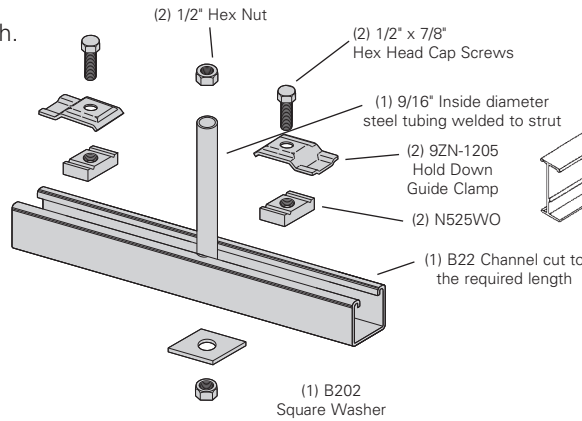

Catalog No.	Tray Width in. (mm)	Channel Length in. (mm)
● 9ZN-5212	6 (152), 9 (229), 12 (305)	18 (457)
● 9ZN-5224	18 (457), 24 (610)	30 (762)

ZN = Zinc Plated

Center Hung Support Hardware Kit

- Kit sold in plastic bag.

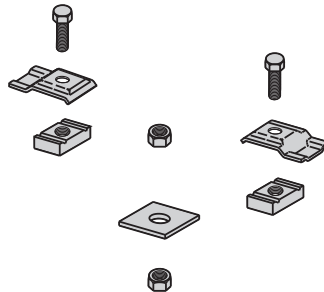

Catalog No.
● 9ZN-5200
1 pr. 9ZN-1205
2 HHC Screw 1/2" x 7/8" ZN
2 N525 WO ZN
1 B202 ZN 1/2" sq washer
2 HN 1/2" ZN

Bracket (12" - 42")

- Finishes available: **ZN** **GRN** or **HDG**
- Safety Load Factor 2.5

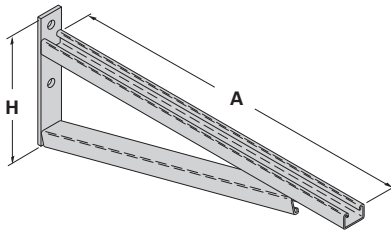

Bottom brace is B42 channel on B494-24 and smaller and B22 channel on B494-30 and larger

Catalog No.	Uniform Load lbs (kN)	Tray Width in. (mm)	'A' in. (mm)	'H' in. (mm)
B494-12	2500 (11.12)	6 & 9 (152 & 229)	12 (305)	8 ³ / ₄ (222)
B494-18	1700 (7.56)	12 (305)	18 (457)	8 ³ / ₄ (222)
B494-24	1300 (5.78)	18 (457)	24 (610)	8 ³ / ₄ (222)
B494-30	1600 (7.11)	24 (610)	30 (762)	11 ¹ / ₄ (286)
B494-36	1100 (4.89)	30 (762)	36 (914)	11 ¹ / ₄ (286)
B494-42	980 (4.36)	36 (914)	42 (1067)	16 (406)

For more dimensional data see Strut Systems catalog

● Green = Fastest shipped items ● Black = Normal lead-time items ● Red = Normally long lead-time items

All dimensions in parentheses are millimeters unless otherwise specified.

Cantilever Bracket

- Finishes available: **ZN** **GRN** **HDG** **SS4** or **SS6**
- Safety Load Factor 2.5

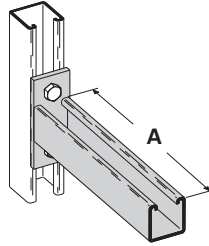

Catalog No.	Uniform Load		Tray Width		'A'	
	lbs	kN	in.	mm	in.	mm
B409-12	960	(4.27)	6 & 9	(152 & 229)	12	(305)
B409-18	640	(2.84)	12	(305)	18	(457)
B409-24	480	(2.13)	18	(457)	24	(610)

Cantilever Bracket

- Finishes available: **ZN** **GRN** **HDG** or **SS4**
- Safety Load Factor 2.5

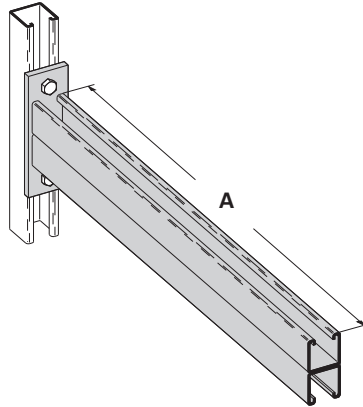

Catalog No.	Uniform Load		Tray Width		'A'	
	lbs	kN	in.	mm	in.	mm
B297-12	1660	(7.38)	6 & 9	(152 & 229)	12	(305)
B297-18	1100	(4.89)	12	(305)	18	(457)
B297-24	835	(3.71)	18	(457)	24	(610)
B297-30	665	(2.95)	24	(610)	30	(762)
B297-36	550	(2.44)	30	(762)	36	(914)
B297-42	465	(2.06)	36	(914)	42	(1067)

Underfloor Support (U-Bolts not included)

- Finish available: **ZN**
- Safety Load Factor 2.5

U-Bolt Size	Fits Pipe O.D.
B501-3/4	.841 - 1.050
B501-1	1.051 - 1.315
B501-1 1/4	1.316 - 1.660
B501-1 1/2	1.661 - 1.900
B501-2	1.901 - 2.375
B501-2 1/2	2.376 - 2.875

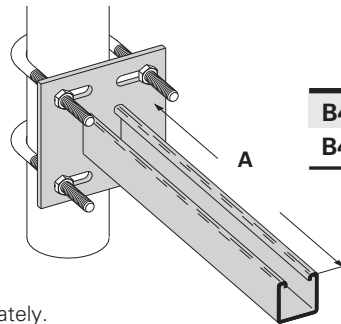

Catalog No.	Uniform Load		Tray Width		'A'	
	lbs	kN	in.	mm	in.	mm
B409UF-12	800	(3.55)	6 & 9	(152 & 229)	12	(305)
B409UF-21	450	(2.00)	12 & 18	(305 & 457)	21	(533)

- Order properly sized U-Bolts separately.

Heavy Duty Hold Down Bracket - Two Bolt

- Design load is 2000 lbs (8.9kN) per pair.
- Two bolt design.
- Sold in pairs.
- 3/8" cable tray attachment hardware provided.
- 1/2" support attachment hardware **not** provided.
- (*) Insert **ZN** **SS4** or **SS6**

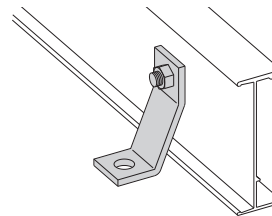

Catalog No.

9(*)-1241

Heavy Duty Hold Down Bracket - Four Bolt

- Design load is 4000 lbs (17.8kN) per pair.
- Four bolt design.
- Sold in pairs.
- 3/8" cable tray attachment hardware provided.
- 1/2" support attachment hardware **not** provided.
- (*) Insert **ZN** **SS4** or **SS6**

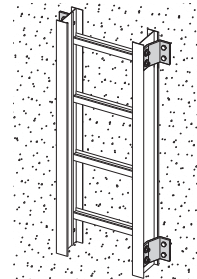
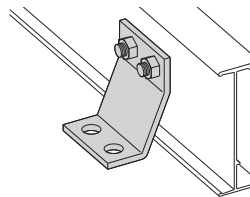

Catalog No.

9(*)-1242

● Green = Fastest shipped items ● Black = Normal lead-time items ● Red = Normally long lead-time items

All dimensions in parentheses are millimeters unless otherwise specified.

Mounting Bracket

- Furnished with 1/4" hardware.
- #12-24 U-Nuts sold separately.
- Attaches to REDI-RAIL in over 20 positions.
- EIA/TIA panel mounting holes - both sides.
- Mounting holes for NEMA outlet/junction boxes.
- Zinc plated steel.
- Includes mounting screws.
- Inside flange application bracket must match side rail height.
- See page RER-16 for Voice/Data/Video and Power Options.

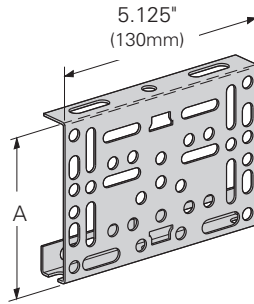

Outside Side Rail Flange Application

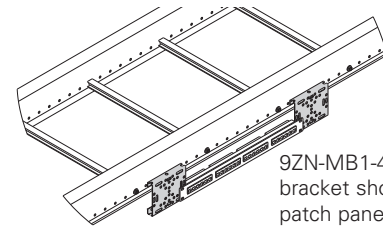

9ZN-MB1-4 mounting bracket shown with patch panels.

Inside Side Rail Flange Application

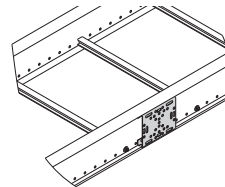

9ZN-MB1-4 mounting bracket shown.

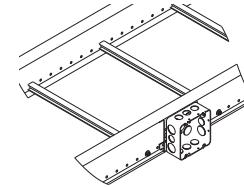

9ZN-MB1-4 mounting bracket shown with 4" electrical box.

Catalog No.	Inside Flange Application	Outside Flange Application	A in (mm)
● 9ZN-MB1-4	4" for RSI04	4" or 5" as desired	3 ⁵ / ₈ (92)
● 9ZN-MB1-5	5" for RSI05	4" or 5" as desired	4 ⁵ / ₈ (117)

Low Voltage Adapter

- Mounting for low voltage wall plates.
- Snaps into mounting bracket 9ZN-MB1-4 or 9ZN-MB1-5.
- Zinc plated steel.
- #6 - 32 U-nuts included.
- See page RER-16 for Voice/Data/Video and Power Options.

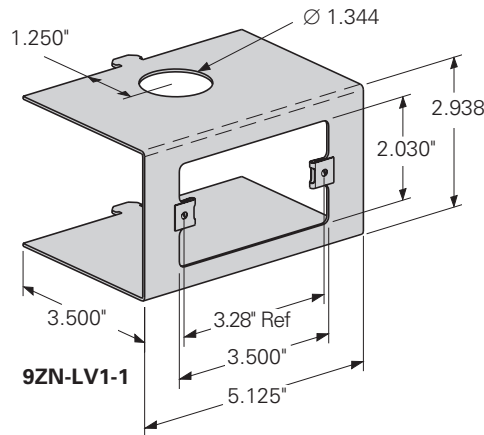

9ZN-LV1-1 shown

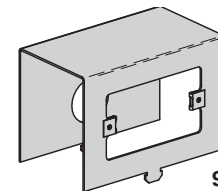
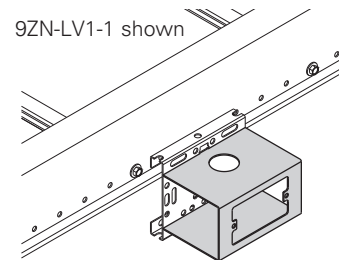

9ZN-LV1A-1

Catalog No.

- 9ZN-LV1-1 (cutout on front)
- 9ZN-LV1A-1 (cutout on bottom)

Under Rung Fastener Attachment

- Supports electrical fixtures from bottom of rung or siderails.
- Wing nut included.
- Various 1/4"-20 stud lengths available.
- Static Load Capacity: 75 Lbs. (34kg).

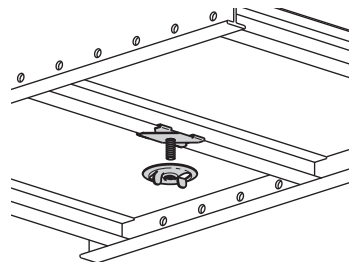
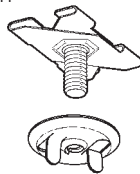

Catalog No.	Stud Length
● BAX-4-16	5/8" (16mm)
● BAX-4-16-24	1 1/2" (38mm)
● BAX-4-16-32	2" (51mm)
● BAX-4-16-48	3" (76mm)

Rooftop Support Bases with B22 Channel

- Designed as a superior rooftop support for cable tray.
- UV resistant and approved for most roofing material or other flat surfaces.
- Can be used with any of Eaton's B-Line series cable tray clamps and guides.
- Ultimate Load Capacity:
1,000 lbs. (4.45kN) - uniform load



LEEDS credit available, base made from 100% recycled material.

Catalog No.	Height x Width x Length
● DB10-28	5 5/8" x 6" x 28.0"
● DB10-36	5 5/8" x 6" x 36.0"
● DB10-42	5 5/8" x 6" x 42.0"
● DB10-50	5 5/8" x 6" x 50.0"
● DB10-60	5 5/8" x 6" x 60.0"

General Note: Consult roofing manufacturer or engineer for roof load capacity. The weakest point may be the insulation board beneath the rubber membrane.

● Green = Fastest shipped items ● Black = Normal lead-time items ● Red = Normally long lead-time items

All dimensions in parentheses are millimeters unless otherwise specified.

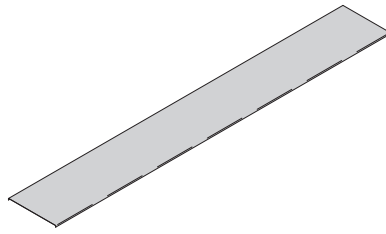

Covers for RSI04A, RSI05A, RSI06A, and RSI07A

Aluminum Cover Part Numbering

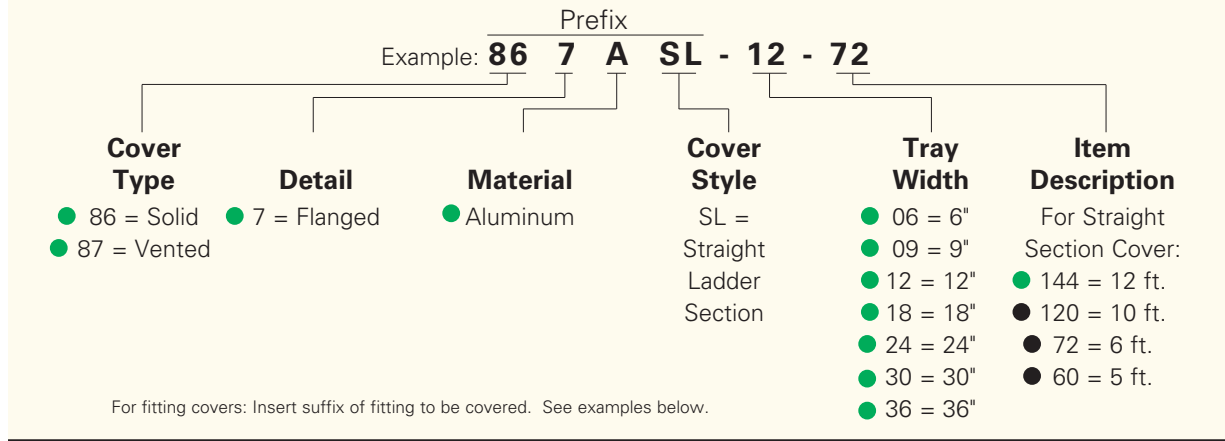

Examples of Catalog Numbers for Fitting Covers:

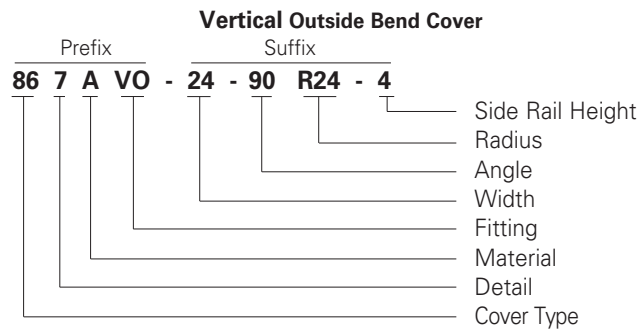
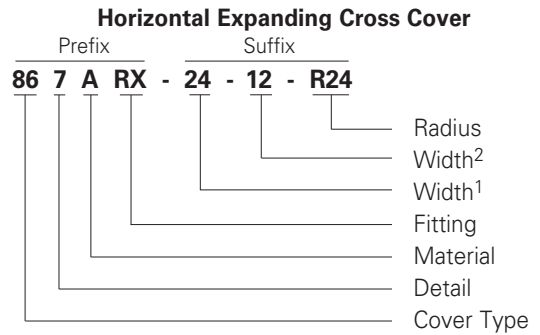
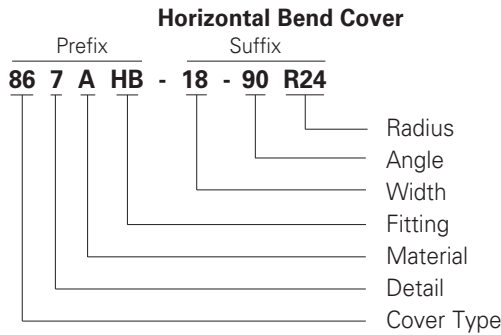

● Green = Fastest shipped items ● Black = Normal lead-time items ● Red = Normally long lead-time items

All dimensions in parentheses are millimeters unless otherwise specified.

Standard Cover Clamp

- Setscrew included.
- For indoor service only.
- Sold per clamp.
- EIA/TIA panel

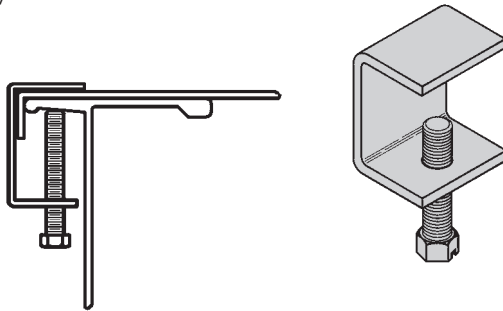

Tray Type	Side Rail Height	Catalog No.
Aluminum	All Sizes	● 9ZN-9012
		● 9A-9012

Heavy Duty Cover Clamp

- For heavy duty application.
- Sold per clamp.

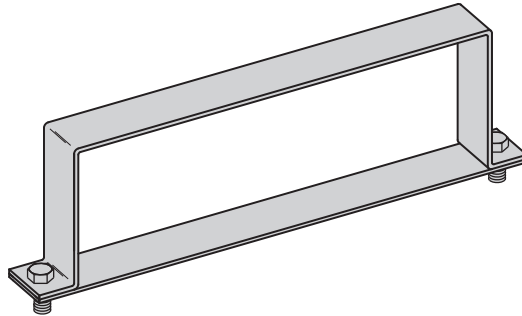

Tray Series	Catalog No.
RSI04A	● R4A-HDCC-†
RSI05A	● R5A-HDCC-†
RSI06A	● R6A-HDCC-†
RSI07A	● R7A-HDCC-†

† = tray width

Quantity of Standard Cover Clamps Required

Straight Section 60" or 72"	4 pcs.
Straight Section 120" or 144"	6 pcs.
Horizontal/Vertical Bends	4 pcs.
Tees	6 pcs.
Crosses	8 pcs.

Notes:

When using the Heavy Duty Cover Clamp, only one-half the number of clamps stated above are required.

Additional clamps may be necessary in extreme wind applications.

● Green = Fastest shipped items ● Black = Normal lead-time items ● Red = Normally long lead-time items

All dimensions in parentheses are millimeters unless otherwise specified.

Out Board Rungs

- Formed aluminum rung with attachment screw.
- Field installs as required.
- Torque rung fasteners to 6 ft•lbs.
- See page RER-16 for Voice/Data/Video and Power Options.
- Uniform load capacity on rung: 10 lbs. (0.04kN)

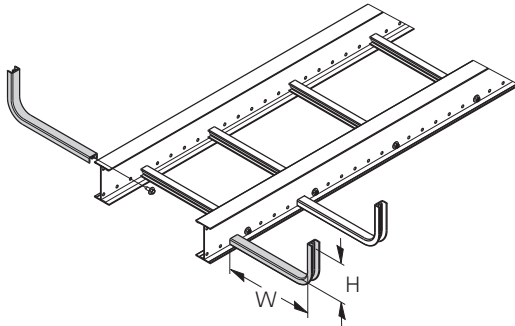

Catalog No.	Fill Depth 'H' in (mm)	For Tray Width 'W' in (mm)
● 9A-SR0406	4 101	6 152
● 9A-SR0409	4 101	9 226
● 9A-SR0506	5 127	6 152
● 9A-SR0509	5 127	9 226

Add-A-Rung™ Kit

- Kit allows an additional rung to be added to a desired location throughout the tray system.
- Pre-cut rung sections supplied.
- Attachment hardware is included.
- Torque rung fasteners to 18 ft•lbs.

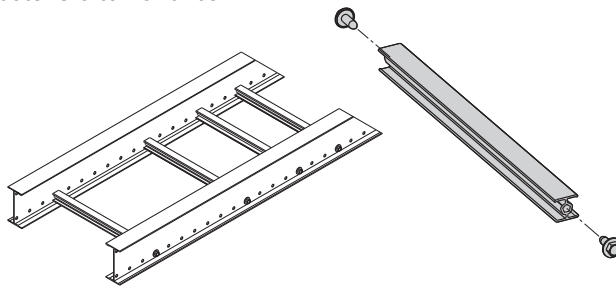

Tray Width in (mm)	Catalog No.
6 (152)	● 9A-R06RK
9 (226)	● 9A-R09RK
12 (305)	● 9A-R12RK
18 (452)	● 9A-R18RK
24 (609)	● 9A-R24RK
30 (762)	● 9A-R30RK
36 (914)	● 9A-R36RK

Barrier Strip Clip

- Provides attachment to Redi-Rail rung.
- Allows for installed barrier adjustment.
- Asymmetrical clip provides a wide range for screw location.
- Barriers strip clips and hardware are included with all barriers.

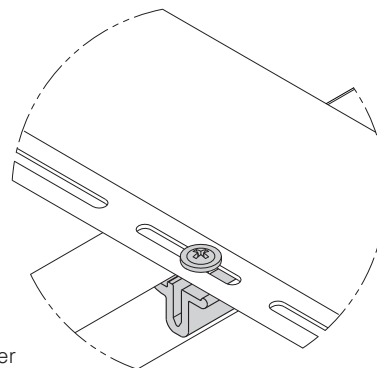
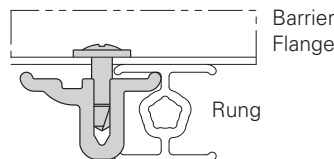
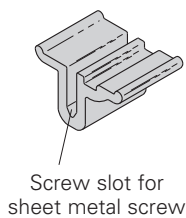

Catalog No.
● 9A-RBC

● Green = Fastest shipped items ● Black = Normal lead-time items ● Red = Normally long lead-time items

All dimensions in parentheses are millimeters unless otherwise specified.

Universal Fitting

- Aluminum construction.
- 2" smooth radius.
- UL Classified.
- Shipped as a 90° horizontal bend.
- Field modify to create a tee or cross.
- Includes four pairs of toolless hinge splice plates.
- Patent Pending.

Tray Series	Catalog No.	
	Punched	Solid
RSI04A	● R4A-UF-(†)	● R4ASB-UF-(†)
RSI05A	● R5A-UF-(†)	● R5ASB-UF-(†)
RSI06A	● R6A-UF-(†)	● R6ASB-UF-(†)
RSI07A	● R7A-UF-(†)	● R7ASB-UF-(†)

(†) Insert Tray Width 6" (152mm) to 24" (609mm)

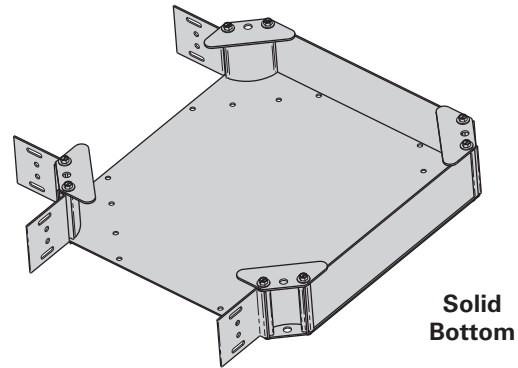
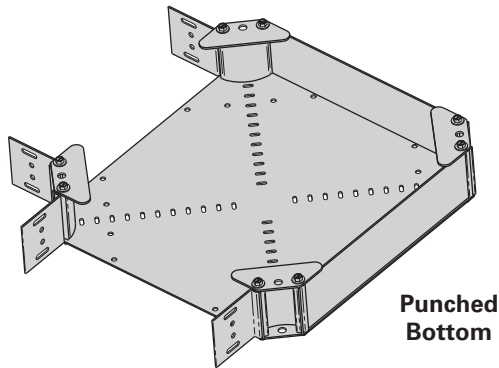

Corner Post For Universal Fitting

- Use to create reducing fittings.
- Furnished with hardware.
- 2" inside radius.
- Used on punched bottom only.
- UL Classified.
- Patent Pending.

Loading Depth	Catalog No.
In. (mm)	
3" (76)	● R4A-CP
4" (101)	● R5A-CP
5" (127)	● R6A-CP
6" (152)	● R7A-CP

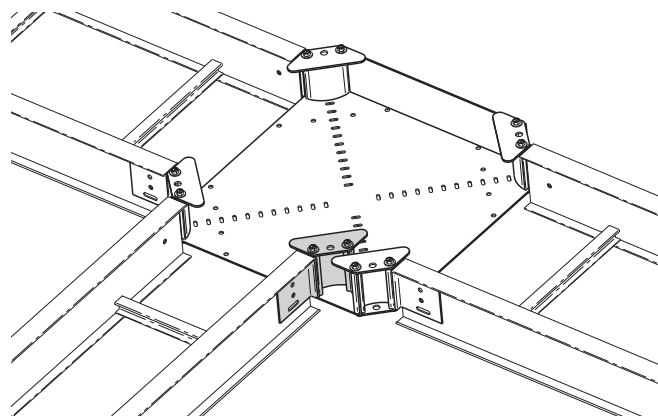
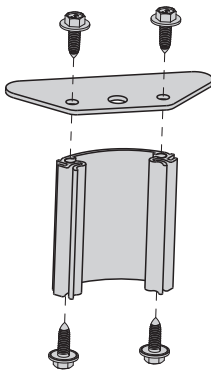

Universal Fitting Shown as a Reducing Tee

● Green = Fastest shipped items ● Black = Normal lead-time items ● Red = Normally long lead-time items

All dimensions in parentheses are millimeters unless otherwise specified.

Straight Section Barrier Strips

- Furnished with four (4) barrier strip clips, mounting hardware and splice.
- Standard lengths are 144" or 12 ft (3.7m) & 120" or 10 ft (3.0m).
- Order catalog number based on loading depth 'H'.

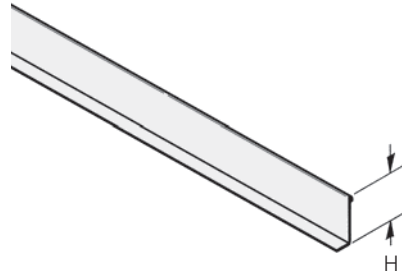

Tray Series	Catalog No.	H in (mm)
RSI04A	● R4A-DSL-Length	3 (76)
RSI05A	● R5A-DSL-Length	4 (101)
RSI06A	● R6A-DSL-Length	5 (127)
RSI07A	● R7A-DSL-Length	6 (152)

Horizontal Bend Barrier Strips

- Furnished with four (4) barrier strip clips, mounting hardware and splice.
- Standard lengths are 72" or 6 ft (1.8m).
- Flexible to fit desired angles.
- Order catalog number based on loading depth 'H'.

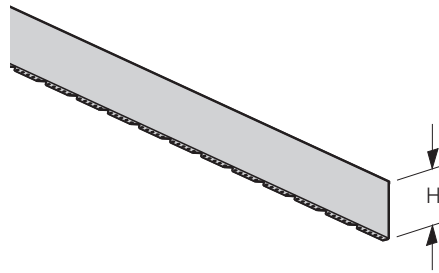

Tray Series	Catalog No.	H in (mm)
RSI04A	● R4A-DHB	3 (76)
RSI05A	● R5A-DHB	4 (101)
RSI06A	● R6A-DHB	5 (127)
RSI07A	● R7A-DHB	6 (152)

Vertical Bend Barrier Strips

- Furnished with three (3) barrier strip clips, mounting hardware and splice.

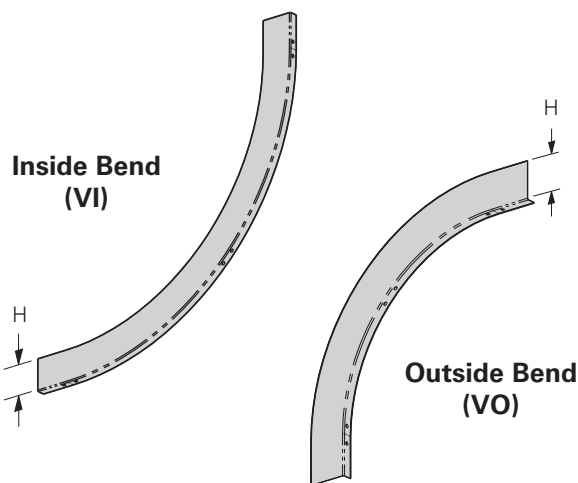

Tray Series	Catalog No.		H in (mm)
	Inside Bend	Outside Bend	
RSI04A	● R4A-DVI-(**R(t))	● R4A-DVO-(**R(t))	3 (76)
RSI05A	● R5A-DVI-(**R(t))	● R5A-DVO-(**R(t))	4 (101)
RSI06A	● R6A-DVI-(**R(t))	● R6A-DVO-(**R(t))	5 (127)
RSI07A	● R7A-DVI-(**R(t))	● R7A-DVO-(**R(t))	6 (152)

(**) Insert for angles: 30°, 45°, 60°, or 90°
 (t) Insert for radius: 12 = 12" (305mm) or 24 = 24" (609mm)

● Green = Fastest shipped items ● Black = Normal lead-time items ● Red = Normally long lead-time items

All dimensions in parentheses are millimeters unless otherwise specified.

How to miter cut REDI-RAIL cable tray for use with FLEX-MOUNT™ splice plates.

- Mark desired hole/cut locations per chart.
- Remove any rungs (if necessary) affected by cuts.
- Cut side rails through center of required holes per chart.
- Mount outside FLEX-MOUNT splice plate with provided hardware and bend REDI-RAIL sections to desired angle.
- Form inside FLEX-MOUNT splice plate to fit contour of inner rails and bolt into place.
- Reinstall (if necessary) appropriate rungs. Torque to 18 ft•lbs.
- If Splice Rung Kit (see below) is required, order separately.
- Recommend adding one to the value in the chart if the first hole is less than $\frac{3}{8}$ " (9.5mm) from the end of tray.

Tray Width	Number Of Holes For Desired Angle				Angle Adjustment Allowed
	30°	45°	60°	90°	
6	1	2	2	4	± 14.5
9	2	2	3	6	± 9.7
12	2	3	4	8	± 7.3
18	3	5	7	11	± 4.9
24	4	6	9	15	± 3.6
30	5	8	11	19	± 2.9
36	6	10	13	23	± 2.4

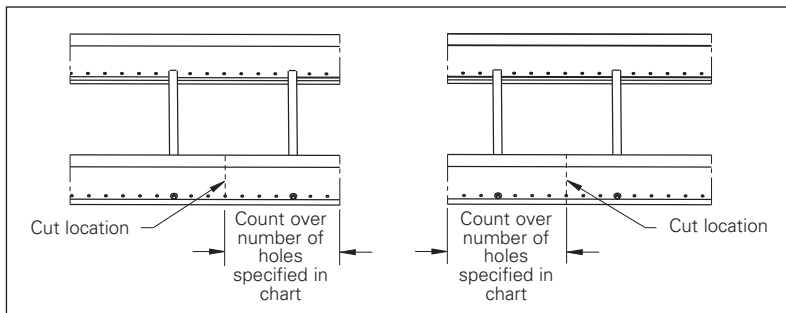

RSI05A09SL-12-144 Straight Section shown with required side rail removed to form 90° fitting.

Example: For a 12" (305mm) wide 90° bend, the cuts must be made through the eighth hole from the end.

FLEX-MOUNT™ Splice Rung Kit

- Kit allows a support rung to be added to flex-mount splice plates so that cables may be supported through a bend.
- The support rung is available in three lengths and should be ordered based upon tray width.
- The rung length is sized so that it will fit a maximum tray width when FLEX-MOUNT splices are used to make a bend up to 90°.
- Once the FLEX-MOUNT splices are installed in the cable tray system, the distance between the splice mounting surfaces should be measured.

Cut support rung to the measured distance and install using the hardware included. Torque to 18 ft•lbs.

For Tray Width		Catalog No.	Actual Rung Length	
in.	(mm)		in.	(mm)
Up to 12	(Up to 305)	● 9A-RFM-12RK	20"	(508)
18 & 24	(453 to 609)	● 9A-RFM-24RK	37"	(940)
30 & 36	(762 to 914)	● 9A-RFM-36RK	54"	(1448)

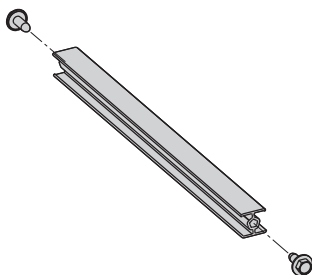

Example: Flex connectors are installed on an 18" (452mm) wide tray with approximately a 45° bend. The correct support rung kit is 9A-RFM-24RK. The tray width is 24" (609mm) or less and the angle is less than 90°.

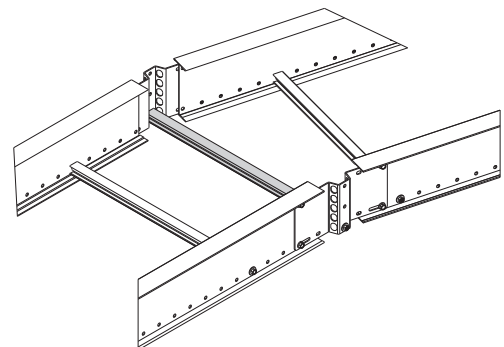

● Green = Fastest shipped items ● Black = Normal lead-time items ● Red = Normally long lead-time items

All dimensions in parentheses are millimeters unless otherwise specified.

Voice / Data / Video Options

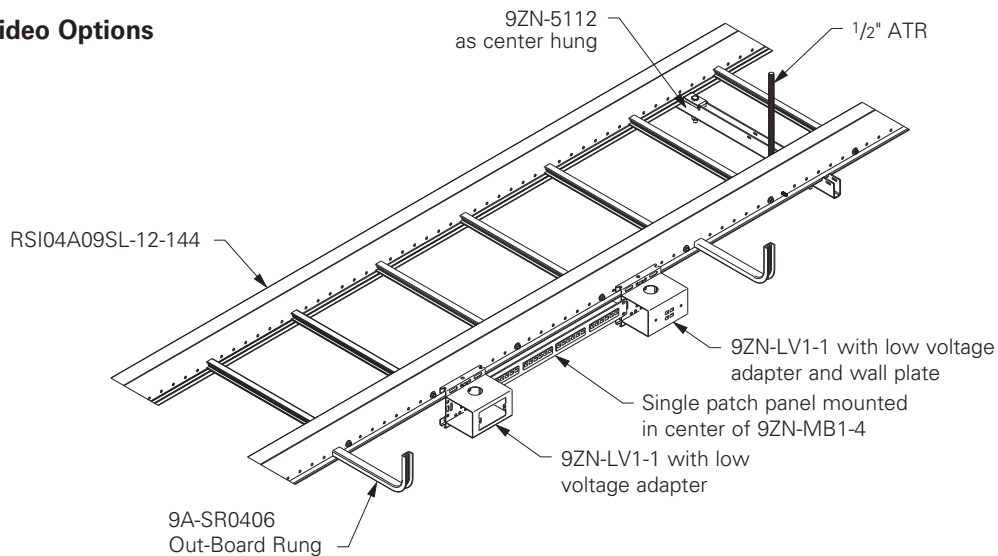

Power Options

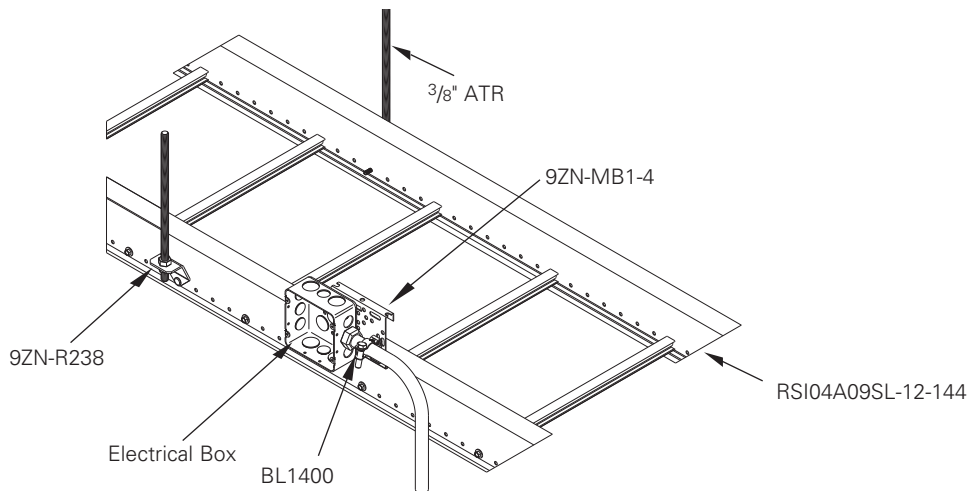

Data Cables

The National Electrical Code allows for 50% fill of ventilated cable tray for control or signal wiring (Article 392-9(b)). This rule requires that all the individual cable cross-sectional areas added up may not exceed one half the cable tray area. The cable tray area is equal to the width times the load depth.

In actual practice with data cables, however, the cable tray becomes completely full in reaching the "50% cable fill". See the picture below. The tray is completely full, but the sum of the cable areas is only 50% of the tray area, due to the empty spaces between the cables.



"50%" Fill Per NEC Cross Sectional Area Calculation

Data Cable Fill and Weight Chart

Number of Category 5/5e/6 Cables and Calculated Cable Weight in Lbs/Ft

Tray Depth in (mm)	Tray Width													
	6" (152mm)		9" (228mm)		12" (305mm)		18" (457mm)		24" (609mm)		30" (762mm)		36" (914mm)	
	Cables	lbs/ft	Cables	lbs/ft	Cables	lbs/ft	Cables	lbs/ft	Cables	lbs/ft	Cables	lbs/ft	Cables	lbs/ft
3" (76)	260	7	390	10	520	14	780	21	1040	26	1299	32	1559	41
4" (101)	347	9	520	13	693	18	1040	27	1386	35	1733	43	2079	54
5" (127)	433	12	650	17	866	23	1299	34	1733	43	2166	53	2599	68
6" (152)	520	14	780	20	1040	27	1559	41	2079	52	2599	64	3119	81

This chart was based on 50% fill of 4 UTP Category 5, 5e, or 6 cables (O.D. = .21" .026 lbs/ft).

In the above loading grid, the weight of the cables is not the issue. The volume capacity of the tray governs. For example, the worst case (6" load depth, 36" wide) has a total cable weight of 81 lbs/ft.

● Green = Fastest shipped items ● Black = Normal lead-time items ● Red = Normally long lead-time items

All dimensions in parentheses are millimeters unless otherwise specified.

Section 161xx - REDI-RAIL™ Cable Tray

Part 1 - General

1.01 Section Includes

- A. The work covered under this section consists of the furnishing of all necessary labor, supervision, materials, equipment, tests and services to install complete cable tray systems as shown on the drawings.
- B. Cable tray systems are defined to include, but are not limited to straight sections of [ladder type] [vented bottom type] [solid bottom type] cable trays, bends, tees, elbows, drop-outs, supports and accessories.

1.02 References

- A. ANSI/NFPA 70 - National Electrical Code
- B. NEMA VE 1-2009 - Metallic Cable Tray Systems
- C. NEMA VE 2-2006 - Cable Tray installation Guidelines

1.03 Drawings

- A. The drawings, which constitute a part of these specifications, indicate the general route of the cable tray systems. Data presented on these drawings are as accurate as preliminary surveys and planning can determine until final equipment selection is made. Accuracy is not guaranteed and field verification, of all dimensions, routing, etc., is directed.
- B. Specifications and drawings are for assistance and guidance, but exact routing, locations, distances and levels will be governed by actual field conditions. Contractor is directed to make field surveys as part of his work prior to submitting system layout drawings.

1.04 Submittals

- A. Submittal Drawings: Submit drawings of cable tray and accessories including clamps, brackets, hanger rods, splice plate connectors, expansion joint assemblies, and fittings, showing accurately scaled components.
- B. Product Data: Submit manufacturer's data on cable tray including, but not limited to, types, materials, finishes, rung spacings, inside depths and fitting radii. For side rails and rungs, submit cross sectional properties including Section Modulus (Sx) and Moment of Inertia (Ix).

1.05 Quality Assurance

- A. Manufacturers: Firms regularly engaged in manufacture of cable trays and fittings of types and capacities required, whose products have been in satisfactory use in similar service for not less than 5 years.
- B. NEMA Compliance: Comply with NEMA Standards Publication Number VE 1, "Cable Tray Systems".
- C. NEC Compliance: Comply with NEC, as applicable to construction and installation of cable tray and cable channel systems (Article 392, NEC).
- D. UL Compliance: Provide products that are UL-classified and labeled.
- E. NFPA Compliance: Comply with NFPA 70B, "Recommended Practice for Electrical Equipment Maintenance" pertaining to installation of cable tray systems.

1.06 Delivery, Storage and Handling

- A. Deliver cable tray systems and components carefully to avoid breakage, denting and scoring finishes. Do not install damaged equipment.
- B. Store cable trays and accessories in original cartons and in clean dry space; protect from weather and construction traffic. Wet materials should be unpacked and dried before storage.

Part 2 - Products

2.01 Acceptable Manufacturers

- A. Subject to compliance with these specifications, B-Line series cable tray systems shall be as manufactured by Eaton.

2.02 Cable Tray Sections and Components

- A. General: Except as otherwise indicated, provide metal cable trays, of types, classes, and sizes indicated; with splice plates, bolts, nuts and washers or connecting units. Construct units with rounded edges and smooth surfaces; in compliance with applicable standards; and with the following additional construction features. Cable tray shall be installed according to the latest revision of NEMA VE-2.
- B. Material and Finish: Straight sections, fitting side rails, rungs and splice plates shall be extruded from Aluminum Association Alloy 6063. All fabricated parts shall be made from Aluminum Association Alloy 5052.

(continued on page F-20)

(continued from page RER-19)

2.03 Type of Tray System

- A. Ladder Cable Trays shall consist of two longitudinal members (side rails) with transverse members (rungs) mechanically fastened to the side rails. Rungs shall be spaced [6] [9] [12] inches apart. Rung spacing in radiused fittings shall be industry standard 9" and measured at the center of the tray's width. Each rung must be capable of supporting a 200 lb. concentrated load at the center of a 18" wide cable tray with a safety factor of 1.5. Rungs shall be capable of easy removal, reinstallation, or replacement if necessary.
- B. Ventilated Bottom Cable Trays shall consist of two longitudinal members (side rails) with rungs spaced 4" apart.
- C. Solid Bottom Cable Trays shall consist of two longitudinal members (side rails) with a solid sheet over rungs spaced on 12" centers.
- D. Cable tray loading depth shall be [3] [4] [5] [6] inches per NEMA VE-1.
- E. Straight sections shall be supplied in standard [10 foot (3.05m)] [12 foot (3.65m)] lengths.
- F. Cable tray widths shall be [6] [9] [12] [18] [24] [30] [36] inches or as shown on drawings.
- G. Splice plates shall have (4) four nuts and bolts per plate. The resistance of fixed splice connections between adjacent sections of tray shall not exceed 0.00033 ohms. Splice plates shall be furnished with straight sections and fittings.
- H. All fittings must have a minimum radius of [12] [24] inches.

2.04 Loading Capacities

- A. Cable trays shall meet NEMA class designation: [75 lbs./ft. on 12 ft. span].
Or
- A. Cable tray shall be capable of carrying a uniformly distributed load of _____ lbs./ft on a _____ foot support span with a safety factor of 1.5 when supported as a simple span and tested per NEMA VE 1 Section 5.2.

Part 3 - Execution

3.01 Installation

- A. Install cable trays as indicated: Installation shall be in accordance with equipment manufacturer's instructions, and with recognized industry practices to ensure that cable tray equipment comply with requirements of NEC and applicable portions of NFPA 70B. Reference NEMA VE-2 for general cable tray installation guidelines.
- B. Coordinate cable tray with other electrical work as necessary to properly integrate installation of cable tray work with other work.
- C. Provide sufficient space encompassing cable trays to permit access for installing and maintaining cables.
- D. Cable tray fitting supports shall be located such that they meet the strength requirements of straight sections. Install fitting supports per NEMA VE-2 guidelines, or in accordance with manufacturer's instructions.

3.02 Testing

- A. Test cable trays to ensure electrical continuity of bonding and grounding connections, and to demonstrate compliance with specified maximum grounding resistance. See NFPA 70B, Chapter 18, for testing and test methods.
- B. Manufacturer shall provide test reports witnessed by an independent testing laboratory of the "worst case" loading conditions outlined in this specification and performed in accordance with the latest revision of NEMA VE-1-2002/CSA C22.2 No. 126.1-02.

End Of Section.

Fittings For RSI04A, RSI05A, RSI06A and RSI07A

Horizontal Bend

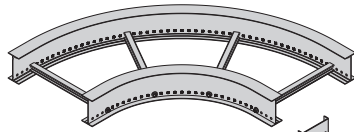

Horizontal Tee

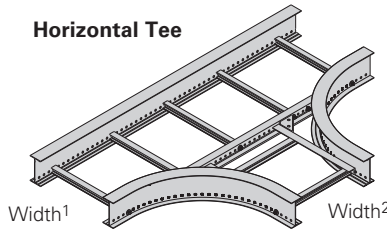

• Furnished with splice plates.

Vertical Inside

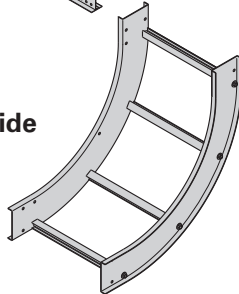

Vertical Outside

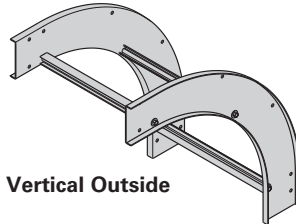

Vertical Tee
Down shown

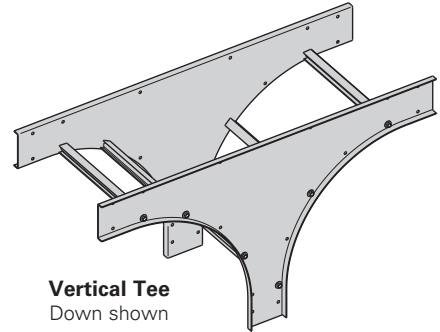

Fittings Part Numbering

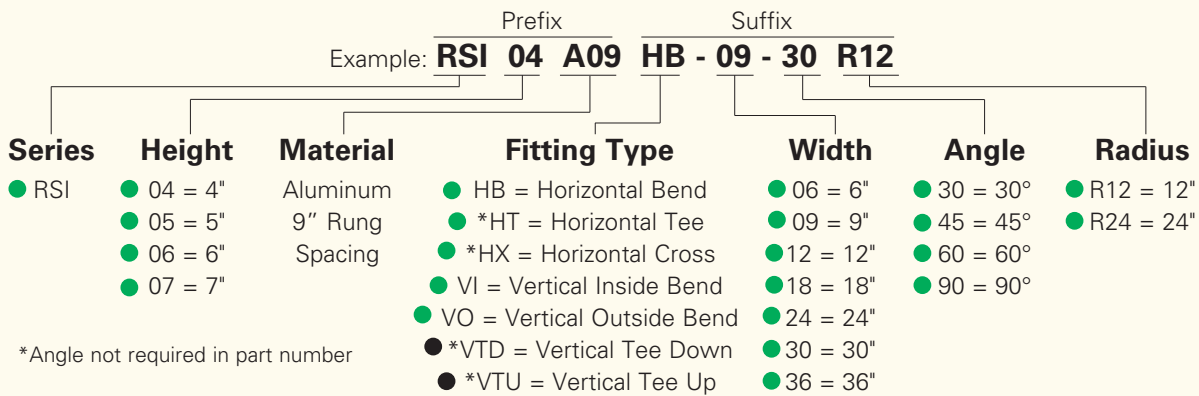

Horizontal Reducing / Expanding Tee or Cross Fittings Part Numbering

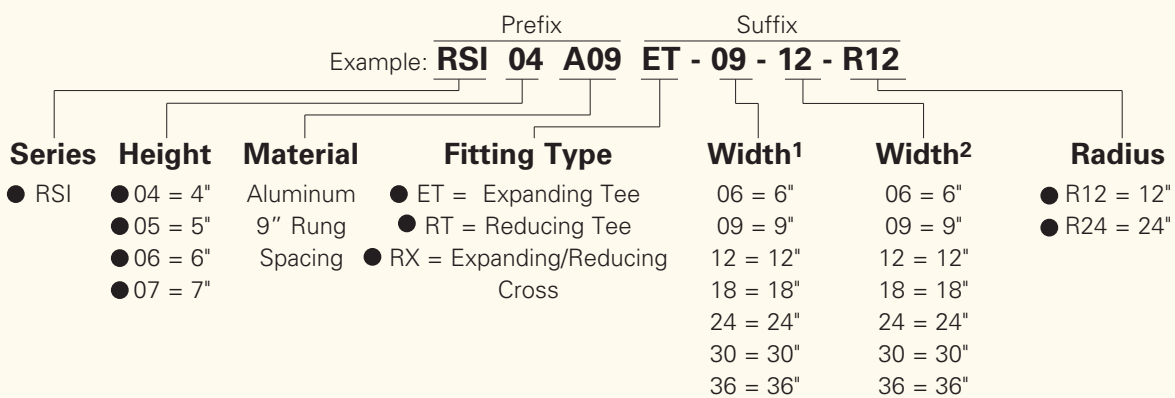

For aluminum 4", 5", 6", 7" vented or non-vented bottom add VB or SB as shown below.

Prefix
RSI05AVBHB - 24 - 90R24
Vented Bottom

Prefix
RSI05ASBHB - 24 - 90R24
Non-Vented Bottom

● Green = Fastest shipped items ● Black = Normal lead-time items ● Red = Normally long lead-time items

All dimensions in parentheses are millimeters unless otherwise specified.

Horizontal Bends 90° 60° 45° 30° (HB)

1 pair splice plates with hardware included.

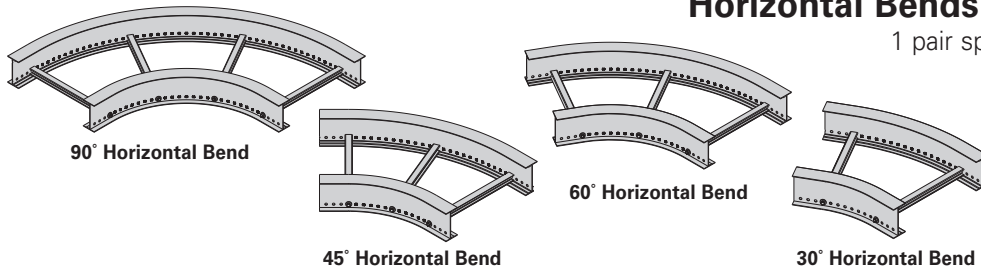

Bottoms manufactured:
09 = 9" Rung Spacing
VB = 4" Rung Spacing
SB = Flat sheet over 12" Rung Spacing

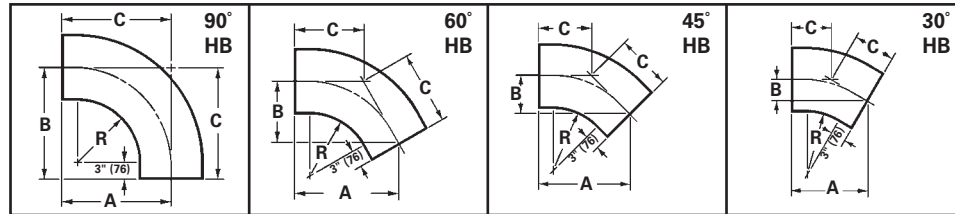

Bend Radius R in. (mm)	Tray Width in. (mm)	90° Horizontal Bend Dimensions				60° Horizontal Bend Dimensions			
		Catalog No.	A in. (mm)	B in. (mm)	C in. (mm)	Catalog No.	A in. (mm)	B in. (mm)	C in. (mm)
12 (305)	6 (152)	(Pre)HB-06-90R12	18 ¹ / ₁₆ (459)	18 ¹ / ₁₆ (459)	18 ¹ / ₁₆ (459)	(Pre)HB-06-60R12	17 ⁹ / ₁₆ (445)	10 ¹ / ₈ (258)	11 ¹¹ / ₁₆ (297)
	9 (228)	(Pre)HB-09-90R12	19 ⁹ / ₁₆ (497)	19 ⁹ / ₁₆ (497)	19 ⁹ / ₁₆ (497)	(Pre)HB-09-60R12	18 ¹³ / ₁₆ (478)	10 ⁷ / ₈ (277)	12 ⁹ / ₁₆ (319)
	12 (305)	(Pre)HB-12-90R12	21 ¹ / ₁₆ (535)	21 ¹ / ₁₆ (535)	21 ¹ / ₁₆ (535)	(Pre)HB-12-60R12	20 ¹ / ₈ (511)	11 ⁵ / ₈ (296)	13 ⁷ / ₁₆ (341)
	18 (457)	(Pre)HB-18-90R12	24 ¹ / ₁₆ (611)	24 ¹ / ₁₆ (611)	24 ¹ / ₁₆ (611)	(Pre)HB-18-60R12	22 ³ / ₄ (577)	13 ¹ / ₈ (334)	15 ³ / ₁₆ (385)
	24 (609)	(Pre)HB-24-90R12	27 ¹ / ₁₆ (687)	27 ¹ / ₁₆ (687)	27 ¹ / ₁₆ (687)	(Pre)HB-24-60R12	25 ⁵ / ₁₆ (643)	14 ⁵ / ₈ (372)	16 ⁷ / ₈ (429)
	30 (762)	(Pre)HB-30-90R12	30 ¹ / ₁₆ (763)	30 ¹ / ₁₆ (763)	30 ¹ / ₁₆ (763)	(Pre)HB-30-60R12	27 ¹⁵ / ₁₆ (709)	16 ¹ / ₈ (410)	18 ⁵ / ₈ (473)
	36 (914)	(Pre)HB-36-90R12	33 ¹ / ₁₆ (840)	33 ¹ / ₁₆ (840)	33 ¹ / ₁₆ (840)	(Pre)HB-36-60R12	30 ¹ / ₂ (775)	17 ⁵ / ₈ (448)	20 ³ / ₈ (517)
24 (609)	6 (152)	(Pre)HB-06-90R24	30 ¹ / ₁₆ (763)	30 ¹ / ₁₆ (763)	30 ¹ / ₁₆ (763)	(Pre)HB-06-60R24	27 ¹⁵ / ₁₆ (709)	16 ¹ / ₈ (410)	18 ⁵ / ₈ (473)
	9 (228)	(Pre)HB-09-90R24	31 ⁹ / ₁₆ (802)	31 ⁹ / ₁₆ (802)	31 ⁹ / ₁₆ (802)	(Pre)HB-09-60R24	29 ¹ / ₄ (742)	16 ⁷ / ₈ (429)	19 ¹ / ₂ (495)
	12 (305)	(Pre)HB-12-90R24	33 ¹ / ₁₆ (840)	33 ¹ / ₁₆ (840)	33 ¹ / ₁₆ (840)	(Pre)HB-12-60R24	30 ¹ / ₂ (775)	17 ⁵ / ₈ (448)	20 ³ / ₈ (517)
	18 (457)	(Pre)HB-18-90R24	36 ¹ / ₁₆ (916)	36 ¹ / ₁₆ (916)	36 ¹ / ₁₆ (916)	(Pre)HB-18-60R24	33 ¹ / ₈ (841)	19 ¹ / ₈ (486)	22 ¹ / ₈ (561)
	24 (609)	(Pre)HB-24-90R24	39 ¹ / ₁₆ (992)	39 ¹ / ₁₆ (992)	39 ¹ / ₁₆ (992)	(Pre)HB-24-60R24	35 ³ / ₄ (907)	20 ⁵ / ₈ (524)	23 ¹³ / ₁₆ (605)
	30 (762)	(Pre)HB-30-90R24	42 ¹ / ₁₆ (1068)	42 ¹ / ₁₆ (1068)	42 ¹ / ₁₆ (1068)	(Pre)HB-30-60R24	38 ⁵ / ₁₆ (973)	22 ¹ / ₈ (562)	25 ⁹ / ₁₆ (649)
	36 (914)	(Pre)HB-36-90R24	45 ¹ / ₁₆ (1144)	45 ¹ / ₁₆ (1144)	45 ¹ / ₁₆ (1144)	(Pre)HB-36-60R24	40 ¹⁵ / ₁₆ (1039)	23 ⁵ / ₈ (600)	27 ⁵ / ₁₆ (693)
45° Horizontal Bend					30° Horizontal Bend				
12 (305)	6 (152)	(Pre)HB-06-45R12	15 ³ / ₄ (400)	6 ¹ / ₂ (165)	9 ³ / ₁₆ (233)	(Pre)HB-06-30R12	13 ³ / ₁₆ (338)	3 ⁹ / ₁₆ (90)	7 ¹ / ₁₆ (180)
	9 (228)	(Pre)HB-09-45R12	16 ¹³ / ₁₆ (427)	6 ¹⁵ / ₁₆ (176)	9 ¹³ / ₁₆ (249)	(Pre)HB-09-30R12	13 ¹⁵ / ₁₆ (354)	3 ³ / ₄ (95)	7 ¹ / ₂ (190)
	12 (305)	(Pre)HB-12-45R12	17 ⁷ / ₈ (454)	7 ⁷ / ₁₆ (189)	10 ¹ / ₂ (267)	(Pre)HB-12-30R12	14 ¹¹ / ₁₆ (373)	3 ¹⁵ / ₁₆ (100)	7 ⁷ / ₈ (200)
	18 (457)	(Pre)HB-18-45R12	20 ¹ / ₂ (521)	8 ⁵ / ₁₆ (211)	11 ⁴ / ₄ (298)	(Pre)HB-18-30R12	16 ³ / ₁₆ (411)	4 ⁵ / ₁₆ (110)	8 ¹¹ / ₁₆ (220)
	24 (609)	(Pre)HB-24-45R12	22 ¹ / ₁₆ (560)	9 ³ / ₁₆ (233)	12 ¹⁵ / ₁₆ (328)	(Pre)HB-24-30R12	17 ¹¹ / ₁₆ (449)	4 ³ / ₄ (120)	9 ¹ / ₂ (241)
	30 (762)	(Pre)HB-30-45R12	24 ⁵ / ₁₆ (617)	10 ¹ / ₁₆ (255)	14 ¹ / ₄ (362)	(Pre)HB-30-30R12	19 ³ / ₁₆ (487)	5 ¹ / ₈ (131)	10 ⁵ / ₁₆ (261)
	36 (914)	(Pre)HB-36-45R12	26 ⁷ / ₁₆ (671)	10 ¹⁵ / ₁₆ (278)	15 ⁷ / ₁₆ (392)	(Pre)HB-36-30R12	20 ¹¹ / ₁₆ (525)	5 ⁹ / ₁₆ (141)	11 ¹ / ₁₆ (282)
24 (609)	6 (152)	(Pre)HB-06-45R24	24 ⁵ / ₁₆ (617)	10 ¹ / ₁₆ (255)	14 ³ / ₁₆ (360)	(Pre)HB-06-30R24	19 ³ / ₁₆ (487)	5 ¹ / ₈ (131)	10 ⁵ / ₁₆ (261)
	9 (228)	(Pre)HB-09-45R24	25 ¹ / ₄ (641)	10 ¹ / ₂ (267)	14 ¹³ / ₁₆ (376)	(Pre)HB-09-30R24	19 ¹⁵ / ₁₆ (506)	5 ⁵ / ₁₆ (136)	10 ¹¹ / ₁₆ (271)
	12 (305)	(Pre)HB-12-45R24	26 ⁷ / ₁₆ (671)	10 ¹⁵ / ₁₆ (278)	15 ⁷ / ₁₆ (392)	(Pre)HB-12-30R24	20 ¹¹ / ₁₆ (525)	5 ⁹ / ₁₆ (141)	11 ¹ / ₁₆ (282)
	18 (457)	(Pre)HB-18-45R24	28 ⁹ / ₁₆ (725)	11 ¹³ / ₁₆ (300)	16 ¹¹ / ₁₆ (424)	(Pre)HB-18-30R24	22 ³ / ₁₆ (563)	5 ¹⁵ / ₁₆ (161)	11 ⁷ / ₈ (302)
	24 (609)	(Pre)HB-24-45R24	30 ¹¹ / ₁₆ (779)	12 ¹¹ / ₁₆ (322)	17 ¹⁵ / ₁₆ (456)	(Pre)HB-24-30R24	23 ¹¹ / ₁₆ (601)	6 ³ / ₈ (161)	12 ¹¹ / ₁₆ (322)
	30 (762)	(Pre)HB-30-45R24	32 ¹³ / ₁₆ (833)	13 ⁹ / ₁₆ (345)	19 ³ / ₁₆ (487)	(Pre)HB-30-30R24	25 ³ / ₁₆ (640)	6 ³ / ₄ (171)	13 ¹ / ₂ (343)
	36 (914)	(Pre)HB-36-45R24	34 ¹⁵ / ₁₆ (887)	14 ⁷ / ₁₆ (367)	20 ⁷ / ₁₆ (519)	(Pre)HB-36-30R24	26 ¹¹ / ₁₆ (678)	7 ¹ / ₈ (182)	14 ⁵ / ₁₆ (363)

(Pre) See page F-21 for catalog number prefix.

Width dimensions are to inside wall. Manufacturing tolerances apply to all dimensions.

All dimensions in parentheses are millimeters unless otherwise specified.

Horizontal Tee (HT)

2 pair splice plates with hardware included.

REDI-RAIL

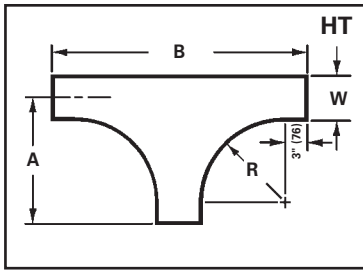
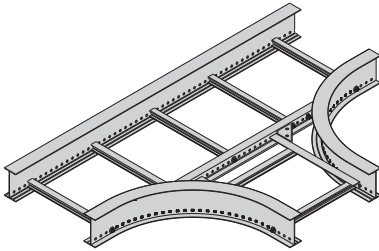

Bend Radius R in. (mm)	Tray Width W in. (mm)	Horizontal Tee Dimensions		
		Catalog No.	A in. (mm)	B in. (mm)
12 (305)	6 (152)	(Prefix)HT-06-R12	18 ¹ / ₁₆ (458)	36 ³ / ₄ (933)
	9 (228)	(Prefix)HT-09-R12	19 ⁹ / ₁₆ (497)	39 ⁷ / ₈ (1013)
	12 (305)	(Prefix)HT-12-R12	21 ¹ / ₁₆ (535)	42 ¹ / ₄ (1073)
	18 (457)	(Prefix)HT-18-R12	24 ¹ / ₁₆ (611)	48 ¹ / ₂ (1232)
	24 (609)	(Prefix)HT-24-R12	27 ¹ / ₁₆ (687)	54 ¹³ / ₁₆ (1392)
	30 (762)	(Prefix)HT-30-R12	30 ¹ / ₁₆ (763)	60 ¹ / ₄ (1530)
24 (609)	36 (914)	(Prefix)HT-36-R12	33 ¹ / ₁₆ (839)	66 ⁹ / ₁₆ (1691)
	6 (152)	(Prefix)HT-06-R24	30 ¹ / ₁₆ (763)	60 ¹ / ₁₆ (1525)
	9 (228)	(Prefix)HT-09-R24	31 ⁹ / ₁₆ (801)	63 ¹ / ₄ (1606)
	12 (305)	(Prefix)HT-12-R24	33 ¹ / ₁₆ (839)	66 ⁹ / ₁₆ (1691)
	18 (457)	(Prefix)HT-18-R24	36 ¹ / ₁₆ (916)	72 ¹ / ₁₆ (1830)
	24 (609)	(Prefix)HT-24-R24	39 ¹ / ₁₆ (992)	78 ³ / ₈ (1991)
	30 (762)	(Prefix)HT-30-R24	42 ¹ / ₁₆ (1068)	84 ⁵ / ₈ (2150)
	36 (914)	(Prefix)HT-36-R24	45 ¹ / ₁₆ (1144)	90 ¹⁵ / ₁₆ (2310)

(Prefix) See page F-21 for catalog number prefix.

Horizontal Cross (HX)

3 pair splice plates with hardware included.

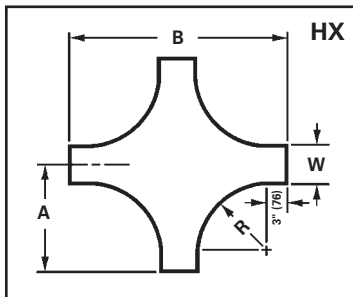
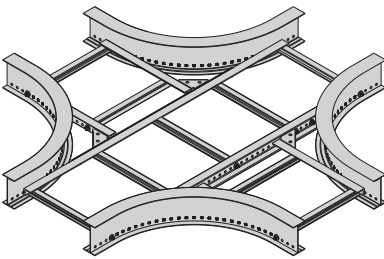

Bend Radius R in. (mm)	Tray Width W in. (mm)	Horizontal Tee Dimensions		
		Catalog No.	A in. (mm)	B in. (mm)
12 (305)	6 (152)	(Prefix)HX-06-R12	18 ¹ / ₁₆ (458)	36 ³ / ₄ (933)
	9 (228)	(Prefix)HX-09-R12	19 ⁹ / ₁₆ (497)	39 ⁷ / ₈ (1013)
	12 (305)	(Prefix)HX-12-R12	21 ¹ / ₁₆ (535)	42 ¹ / ₄ (1073)
	18 (457)	(Prefix)HX-18-R12	24 ¹ / ₁₆ (611)	48 ¹ / ₂ (1232)
	24 (609)	(Prefix)HX-24-R12	27 ¹ / ₁₆ (687)	54 ¹³ / ₁₆ (1392)
	30 (762)	(Prefix)HX-30-R12	30 ¹ / ₁₆ (763)	60 ¹ / ₄ (1530)
24 (609)	36 (914)	(Prefix)HX-36-R12	33 ¹ / ₁₆ (839)	66 ⁹ / ₁₆ (1691)
	6 (152)	(Prefix)HX-06-R24	30 ¹ / ₁₆ (763)	60 ¹ / ₁₆ (1525)
	9 (228)	(Prefix)HX-09-R24	31 ⁹ / ₁₆ (801)	63 ¹ / ₄ (1606)
	12 (305)	(Prefix)HX-12-R24	33 ¹ / ₁₆ (839)	66 ⁹ / ₁₆ (1691)
	18 (457)	(Prefix)HX-18-R24	36 ¹ / ₁₆ (916)	72 ¹ / ₁₆ (1830)
	24 (609)	(Prefix)HX-24-R24	39 ¹ / ₁₆ (992)	78 ³ / ₈ (1991)
	30 (762)	(Prefix)HX-30-R24	42 ¹ / ₁₆ (1068)	84 ⁵ / ₈ (2150)
	36 (914)	(Prefix)HX-36-R24	45 ¹ / ₁₆ (1144)	90 ¹⁵ / ₁₆ (2310)

(Prefix) See page F-21 for catalog number prefix.

Width dimensions are to inside wall. Manufacturing tolerances apply to all dimensions.

All dimensions in parentheses are millimeters unless otherwise specified.

Horizontal Reducing Tee (RT)

2 pair splice plates with hardware included.

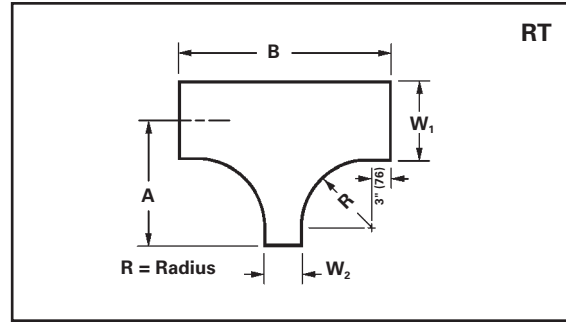
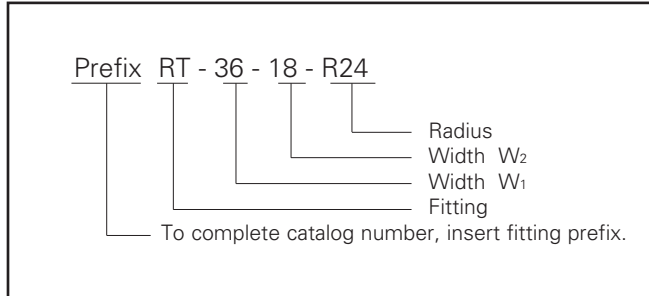
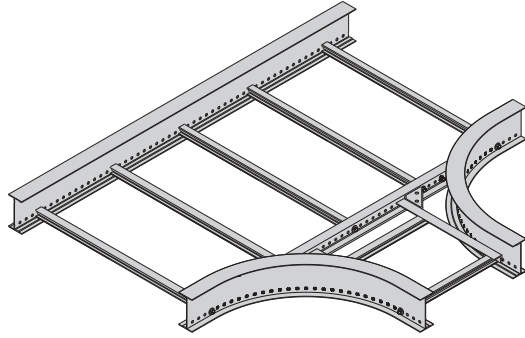

REDI-RAIL

Tray Width		* Insert Radius (12 for 12", 24 for 24") Catalog No.	12" Radius		24" Radius	
W1 in. (mm)	W2 in. (mm)		A in. (mm)	B in. (mm)	A in. (mm)	B in. (mm)
9 (228)	6 (152)	(Prefix)RT-09-06-R*	19 ⁹ / ₁₆ (497)	36 ³ / ₄ (933)	31 ⁹ / ₁₆ (801)	61 ¹ / ₁₆ (1551)
12 (305)	6 (152)	(Prefix)RT-12-06-R*	21 ¹ / ₁₆ (535)	36 ³ / ₄ (933)	33 ¹ / ₁₆ (839)	61 ¹ / ₁₆ (1551)
	9 (228)	(Prefix)RT-12-09-R*	21 ¹ / ₁₆ (535)	39 ⁷ / ₈ (1013)	33 ¹ / ₁₆ (839)	64 ¹ / ₄ (1830)
18 (457)	6 (152)	(Prefix)RT-18-06-R*	24 ¹ / ₁₆ (611)	36 ³ / ₄ (933)	36 ¹ / ₁₆ (916)	61 ¹ / ₁₆ (1551)
	9 (228)	(Prefix)RT-18-09-R*	24 ¹ / ₁₆ (611)	39 ⁷ / ₈ (1013)	36 ¹ / ₁₆ (916)	64 ¹ / ₄ (1830)
	12 (305)	(Prefix)RT-18-12-R*	24 ¹ / ₁₆ (611)	42 ¹ / ₄ (1073)	36 ¹ / ₁₆ (916)	66 ⁹ / ₁₆ (1691)
24 (609)	6 (152)	(Prefix)RT-24-06-R*	27 ¹ / ₁₆ (687)	36 ³ / ₄ (933)	39 ¹ / ₁₆ (992)	61 ¹ / ₁₆ (1551)
	9 (228)	(Prefix)RT-24-09-R*	27 ¹ / ₁₆ (687)	39 ⁷ / ₈ (1013)	39 ¹ / ₁₆ (992)	64 ¹ / ₄ (1830)
	12 (305)	(Prefix)RT-24-12-R*	27 ¹ / ₁₆ (687)	42 ¹ / ₄ (1073)	39 ¹ / ₁₆ (992)	66 ⁹ / ₁₆ (1691)
	18 (457)	(Prefix)RT-24-18-R*	27 ¹ / ₁₆ (687)	48 ¹ / ₂ (1232)	39 ¹ / ₁₆ (992)	72 ¹ / ₁₆ (1830)
30 (762))	6 (152)	(Prefix)RT-30-06-R*	30 ¹ / ₁₆ (763)	36 ³ / ₄ (933)	42 ¹ / ₁₆ (1068)	61 ¹ / ₁₆ (1551)
	9 (228)	(Prefix)RT-30-09-R*	30 ¹ / ₁₆ (763)	39 ⁷ / ₈ (1013)	42 ¹ / ₁₆ (1068)	64 ¹ / ₄ (1830)
	12 (305)	(Prefix)RT-30-12-R*	30 ¹ / ₁₆ (763)	42 ¹ / ₄ (1073)	42 ¹ / ₁₆ (1068)	66 ⁹ / ₁₆ (1691)
	18 (457)	(Prefix)RT-30-18-R*	30 ¹ / ₁₆ (763)	48 ¹ / ₂ (1232)	42 ¹ / ₁₆ (1068)	72 ¹ / ₁₆ (1830)
	24 (609)	(Prefix)RT-30-24-R*	30 ¹ / ₁₆ (763)	54 ¹³ / ₁₆ (1392)	42 ¹ / ₁₆ (1068)	78 ³ / ₈ (1991)
36 (914)	6 (152)	(Prefix)RT-36-06-R*	33 ¹ / ₁₆ (839)	36 ³ / ₄ (933)	45 ¹ / ₁₆ (1144)	61 ¹ / ₁₆ (1551)
	9 (228)	(Prefix)RT-36-09-R*	33 ¹ / ₁₆ (839)	39 ⁷ / ₈ (1013)	45 ¹ / ₁₆ (1144)	64 ¹ / ₄ (1830)
	12 (305)	(Prefix)RT-36-12-R*	33 ¹ / ₁₆ (839)	42 ¹ / ₄ (1073)	45 ¹ / ₁₆ (1144)	66 ⁹ / ₁₆ (1691)
	18 (457)	(Prefix)RT-36-18-R*	33 ¹ / ₁₆ (839)	48 ¹ / ₂ (1232)	45 ¹ / ₁₆ (1144)	72 ¹ / ₁₆ (1830)
	24 (609)	(Prefix)RT-36-24-R*	33 ¹ / ₁₆ (839)	54 ¹³ / ₁₆ (1392)	45 ¹ / ₁₆ (1144)	78 ³ / ₈ (1991)
	36 (914)	(Prefix)RT-36-30-R*	33 ¹ / ₁₆ (839)	60 ¹ / ₄ (1530)	45 ¹ / ₁₆ (1144)	84 ⁵ / ₈ (2149)

(Prefix) See page F-21 for catalog number prefix.
 Width dimensions are to inside wall.
 Manufacturing tolerances apply to all dimensions.

All dimensions in parentheses are millimeters unless otherwise specified.

Horizontal Expanding Tee (ET)

2 pair splice plates with hardware included.

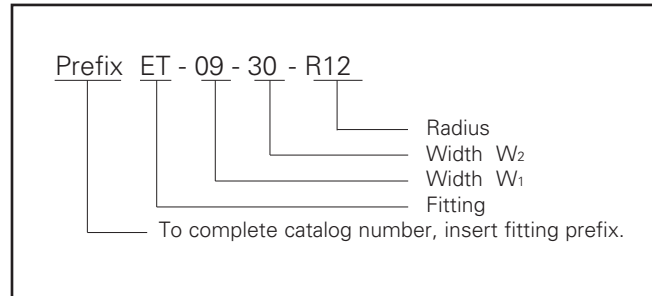
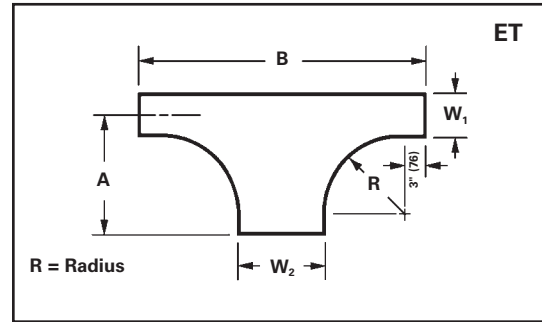
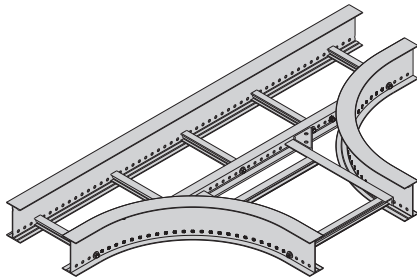

Tray Width		* Insert Radius (12 for 12", 24 for 24") Catalog No.	12" Radius		24" Radius	
W1 in. (mm)	W2 in. (mm)		A in. (mm)	B in. (mm)	A in. (mm)	B in. (mm)
6 (152)	9 (228)	(Prefix)ET-06-09-R*	18 ¹ / ₁₆ (458)	39 ⁷ / ₈ (1013)	30 ¹ / ₁₆ (763)	64 ¹ / ₄ (1632)
	12 (305)	(Prefix)ET-06-12-R*	18 ¹ / ₁₆ (458)	42 ¹ / ₄ (1073)	30 ¹ / ₁₆ (763)	66 ⁹ / ₁₆ (1691)
	18 (457)	(Prefix)ET-06-18-R*	18 ¹ / ₁₆ (458)	48 ¹ / ₂ (1232)	30 ¹ / ₁₆ (763)	72 ¹ / ₁₆ (1830)
	24 (609)	(Prefix)ET-06-24-R*	18 ¹ / ₁₆ (458)	54 ¹³ / ₁₆ (1392)	30 ¹ / ₁₆ (763)	78 ³ / ₈ (1991)
	30 (762)	(Prefix)ET-06-30-R*	18 ¹ / ₁₆ (458)	60 ¹ / ₄ (1530)	30 ¹ / ₁₆ (763)	84 ⁵ / ₈ (2149)
	36 (914)	(Prefix)ET-06-36-R*	18 ¹ / ₁₆ (458)	66 ⁹ / ₁₆ (1691)	30 ¹ / ₁₆ (763)	90 ¹⁵ / ₁₆ (2310)
9 (228)	12 (305)	(Prefix)ET-09-12-R*	19 ⁹ / ₁₆ (497)	42 ¹ / ₄ (1073)	31 ⁹ / ₁₆ (801)	66 ⁹ / ₁₆ (1691)
	18 (457)	(Prefix)ET-09-18-R*	19 ⁹ / ₁₆ (497)	48 ¹ / ₂ (1232)	31 ⁹ / ₁₆ (801)	72 ¹ / ₁₆ (1830)
	24 (609)	(Prefix)ET-09-24-R*	19 ⁹ / ₁₆ (497)	54 ¹³ / ₁₆ (1392)	31 ⁹ / ₁₆ (801)	78 ³ / ₈ (1991)
	30 (762)	(Prefix)ET-09-30-R*	19 ⁹ / ₁₆ (497)	60 ¹ / ₄ (1530)	31 ⁹ / ₁₆ (801)	84 ⁵ / ₈ (2149)
	36 (914)	(Prefix)ET-09-36-R*	19 ⁹ / ₁₆ (497)	66 ⁹ / ₁₆ (1691)	31 ⁹ / ₁₆ (801)	90 ¹⁵ / ₁₆ (2310)
12 (305)	18 (457)	(Prefix)ET-12-18-R*	21 ¹ / ₁₆ (535)	48 ¹ / ₂ (1232)	33 ¹ / ₁₆ (839)	72 ¹ / ₁₆ (1830)
	24 (609)	(Prefix)ET-12-24-R*	21 ¹ / ₁₆ (535)	54 ¹³ / ₁₆ (1392)	33 ¹ / ₁₆ (839)	78 ³ / ₈ (1991)
	30 (762)	(Prefix)ET-12-30-R*	21 ¹ / ₁₆ (535)	60 ¹ / ₄ (1530)	33 ¹ / ₁₆ (839)	84 ⁵ / ₈ (2149)
	36 (914)	(Prefix)ET-12-36-R*	21 ¹ / ₁₆ (535)	66 ⁹ / ₁₆ (1691)	33 ¹ / ₁₆ (839)	90 ¹⁵ / ₁₆ (2310)
18 (457)	24 (609)	(Prefix)ET-18-24-R*	24 ¹ / ₁₆ (611)	54 ¹³ / ₁₆ (1392)	36 ¹ / ₁₆ (916)	78 ³ / ₈ (1991)
	30 (762)	(Prefix)ET-18-30-R*	24 ¹ / ₁₆ (611)	60 ¹ / ₄ (1530)	36 ¹ / ₁₆ (916)	84 ⁵ / ₈ (2149)
	36 (914)	(Prefix)ET-18-36-R*	24 ¹ / ₁₆ (611)	66 ⁹ / ₁₆ (1691)	36 ¹ / ₁₆ (916)	90 ¹⁵ / ₁₆ (2310)
24 (609)	30 (762)	(Prefix)ET-24-30-R*	27 ¹ / ₁₆ (687)	60 ¹ / ₄ (1530)	39 ¹ / ₁₆ (992)	84 ⁵ / ₈ (2149)
	36 (914)	(Prefix)ET-24-36-R*	27 ¹ / ₁₆ (687)	66 ⁹ / ₁₆ (1691)	39 ¹ / ₁₆ (992)	90 ¹⁵ / ₁₆ (2310)
30 (762)	36 (914)	(Prefix)ET-30-36-R*	30 ¹ / ₁₆ (763)	66 ⁹ / ₁₆ (1691)	42 ¹ / ₁₆ (1068)	90 ¹⁵ / ₁₆ (2310)

(Prefix) See page F-21 for catalog number prefix.

Width dimensions are to inside wall.

Manufacturing tolerances apply to all dimensions.

All dimensions in parentheses are millimeters unless otherwise specified.

Horizontal Expanding/Reducing Cross (RX)

3 pair splice plates with hardware included.

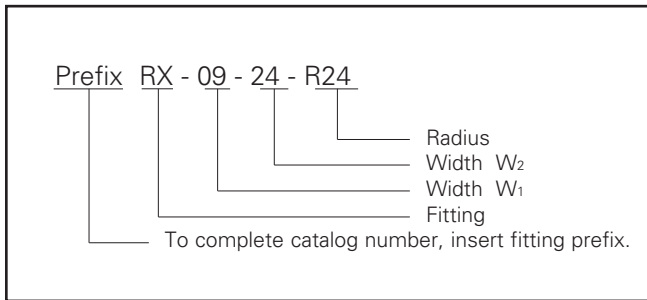
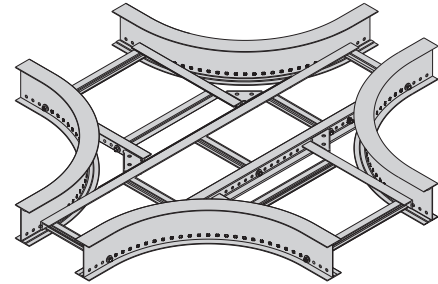
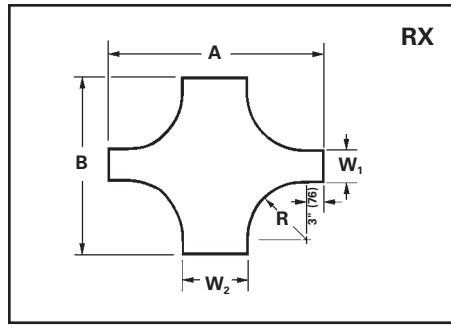

Tray Width		* Insert Radius (12 for 12", 24 for 24") Catalog No.	12" Radius		24" Radius	
W1 in. (mm)	W2 in. (mm)		A in. (mm)	B in. (mm)	A in. (mm)	B in. (mm)
6 (152)	9 (228)	(Prefix)RX-06-09-R*	36 ³ / ₄ (933)	39 ⁷ / ₈ (1013)	60 ¹ / ₁₆ (1525)	64 ¹ / ₄ (1632)
	12 (305)	(Prefix)RX-06-12-R*	36 ³ / ₄ (933)	42 ¹ / ₄ (1073)	60 ¹ / ₁₆ (1525)	66 ⁹ / ₁₆ (1691)
	18 (457)	(Prefix)RX-06-18-R*	36 ³ / ₄ (933)	48 ¹ / ₂ (1232)	60 ¹ / ₁₆ (1525)	72 ¹ / ₁₆ (1830)
	24 (609)	(Prefix)RX-06-24-R*	36 ³ / ₄ (933)	54 ¹³ / ₁₆ (1392)	60 ¹ / ₁₆ (1525)	78 ³ / ₈ (1991)
	30 (762)	(Prefix)RX-06-30-R*	36 ³ / ₄ (933)	60 ¹ / ₄ (1530)	60 ¹ / ₁₆ (1525)	84 ⁵ / ₈ (2149)
	36 (914)	(Prefix)RX-06-36-R*	36 ³ / ₄ (933)	66 ⁹ / ₁₆ (1691)	60 ¹ / ₁₆ (1525)	90 ¹⁵ / ₁₆ (2310)
9 (228)	12 (305)	(Prefix)RX-09-12-R*	39 ⁷ / ₈ (1013)	42 ¹ / ₄ (1073)	64 ¹ / ₄ (1632)	66 ⁹ / ₁₆ (1691)
	18 (457)	(Prefix)RX-09-18-R*	39 ⁷ / ₈ (1013)	48 ¹ / ₂ (1232)	64 ¹ / ₄ (1632)	72 ¹ / ₁₆ (1830)
	24 (609)	(Prefix)RX-09-24-R*	39 ⁷ / ₈ (1013)	54 ¹³ / ₁₆ (1392)	64 ¹ / ₄ (1632)	78 ³ / ₈ (1991)
	30 (762)	(Prefix)RX-09-30-R*	39 ⁷ / ₈ (1013)	60 ¹ / ₄ (1530)	64 ¹ / ₄ (1632)	84 ⁵ / ₈ (2149)
	36 (914)	(Prefix)RX-09-36-R*	39 ⁷ / ₈ (1013)	66 ⁹ / ₁₆ (1691)	64 ¹ / ₄ (1632)	90 ¹⁵ / ₁₆ (2310)
12 (305)	18 (457)	(Prefix)RX-12-18-R*	42 ¹ / ₄ (1073)	48 ¹ / ₂ (1232)	66 ⁹ / ₁₆ (1691)	72 ¹ / ₁₆ (1830)
	24 (609)	(Prefix)RX-12-24-R*	42 ¹ / ₄ (1073)	54 ¹³ / ₁₆ (1392)	66 ⁹ / ₁₆ (1691)	78 ³ / ₈ (1991)
	30 (762)	(Prefix)RX-12-30-R*	42 ¹ / ₄ (1073)	60 ¹ / ₄ (1530)	66 ⁹ / ₁₆ (1691)	84 ⁵ / ₈ (2149)
	36 (914)	(Prefix)RX-12-36-R*	42 ¹ / ₄ (1073)	66 ⁹ / ₁₆ (1691)	66 ⁹ / ₁₆ (1691)	90 ¹⁵ / ₁₆ (2310)
18 (457)	24 (609)	(Prefix)RX-18-24-R*	48 ¹ / ₂ (1232)	54 ¹³ / ₁₆ (1392)	72 ¹ / ₁₆ (1830)	78 ³ / ₈ (1991)
	30 (762)	(Prefix)RX-18-30-R*	48 ¹ / ₂ (1232)	60 ¹ / ₄ (1530)	72 ¹ / ₁₆ (1830)	84 ⁵ / ₈ (2149)
	36 (914)	(Prefix)RX-18-36-R*	48 ¹ / ₂ (1232)	66 ⁹ / ₁₆ (1691)	72 ¹ / ₁₆ (1830)	90 ¹⁵ / ₁₆ (2310)
24 (609)	30 (762)	(Prefix)RX-24-30-R*	54 ¹³ / ₁₆ (1392)	60 ¹ / ₄ (1530)	78 ³ / ₈ (1991)	84 ⁵ / ₈ (2149)
	36 (914)	(Prefix)RX-24-36-R*	54 ¹³ / ₁₆ (1392)	66 ⁹ / ₁₆ (1691)	78 ³ / ₈ (1991)	90 ¹⁵ / ₁₆ (2310)
30 (762)	36 (914)	(Prefix)RX-30-36-R*	60 ¹ / ₄ (1530)	66 ⁹ / ₁₆ (1691)	84 ⁵ / ₈ (2149)	90 ¹⁵ / ₁₆ (2310)

(Prefix) See page F-21 for catalog number prefix.

Width dimensions are to inside wall.

Manufacturing tolerances apply to all dimensions.

All dimensions in parentheses are millimeters unless otherwise specified.

Vertical Bend 90° (VO, VI)

1 pair splice plates with hardware included.

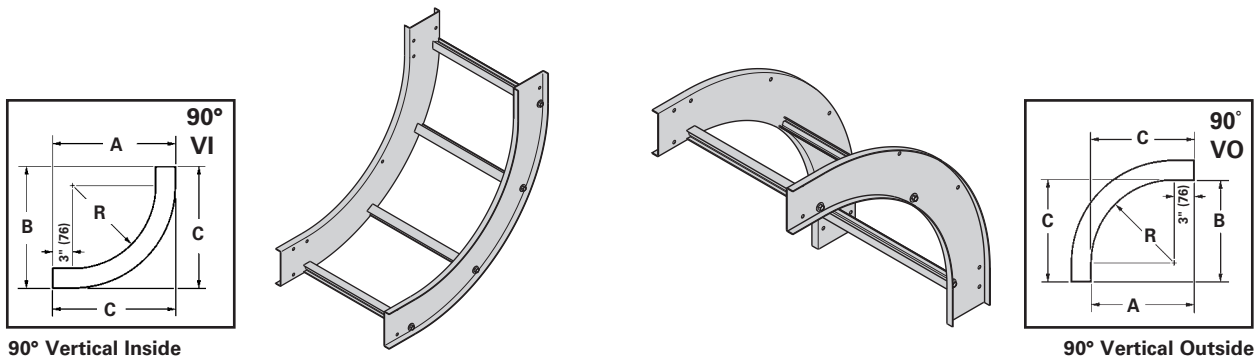

90° Vertical Inside

90° Vertical Outside

90° Vertical Inside (VI) Bend

Bend Radius R in. (mm)	Width in. (mm)	Catalog No.	Siderail Height											
			4"			5"			6"			7"		
			A	B	C	A	B	C	A	B	C	A	B	C
12 (305)	6 (152)	(Pre)VI-06-90R12												
	9 (228)	(Pre)VI-09-90R12												
	12 (305)	(Pre)VI-12-90R12	18 1/2"	18 1/2"	18 1/2"	19 1/2"	19 1/2"	19 1/2"	20 1/2"	20 1/2"	20 1/2"	21 1/2"	21 1/2"	21 1/2"
	18 (457)	(Pre)VI-18-90R12	(470)	(470)	(470)	(495)	(495)	(495)	(521)	(521)	(521)	(546)	(546)	(546)
	24 (609)	(Pre)VI-24-90R12												
	36 (914)	(Pre)VI-36-90R12												
24 (609)	6 (152)	(Pre)VI-06-90R24												
	9 (228)	(Pre)VI-09-90R24												
	12 (305)	(Pre)VI-12-90R24	30 1/2"	30 1/2"	30 1/2"	31 1/2"	31 1/2"	31 1/2"	32 1/2"	32 1/2"	32 1/2"	33 1/2"	33 1/2"	33 1/2"
	18 (457)	(Pre)VI-18-90R24	(851)	(851)	(851)	(800)	(800)	(800)	(825)	(825)	(825)	(851)	(851)	(851)
	24 (609)	(Pre)VI-24-90R24												
	30 (762)	(Pre)VI-30-90R24												
36 (914)	(Pre)VI-36-90R24													

90° Vertical Inside (VO) Bend

Bend Radius R in. (mm)	Width in. (mm)	Catalog No.	Siderail Height 4"-7"		
			A	B	C
12 (305)	6 (152)	(Pre)VO-06-90R12			
	9 (228)	(Pre)VO-09-90R12			
	12 (305)	(Pre)VO-12-90R12	15"	15"	15"
	18 (457)	(Pre)VO-18-90R12	(381)	(381)	(381)
	24 (609)	(Pre)VO-24-90R12			
	36 (914)	(Pre)VO-36-90R12			
24 (609)	6 (152)	(Pre)VO-06-90R24			
	9 (228)	(Pre)VO-09-90R24			
	12 (305)	(Pre)VO-12-90R24	27"	27"	27"
	18 (457)	(Pre)VO-18-90R24	(686)	(686)	(686)
	24 (609)	(Pre)VO-24-90R24			
	36 (914)	(Pre)VO-36-90R24			

(Pre) See page F-21 for catalog number prefix.

Manufacturing tolerances apply to all dimensions.

All dimensions in parentheses are millimeters unless otherwise specified.

Vertical Bend 60° (VO, VI)

1 pair splice plates with hardware included.

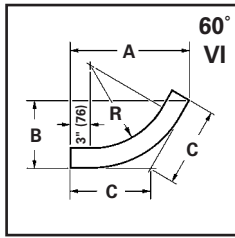

60° Vertical Inside

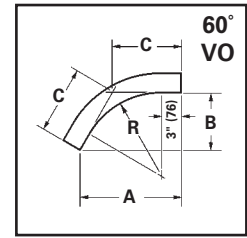
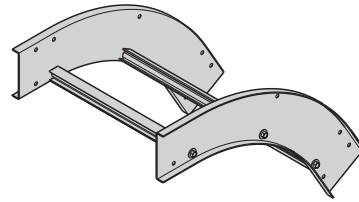
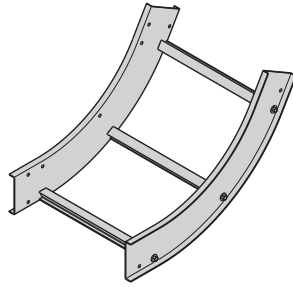

60° Vertical Outside

60° Vertical Inside (VI) Bend

Bend Radius R in. (mm)	Width in. (mm)	Catalog No.	Siderail Height											
			4"			5"			6"			7"		
			A	B	C	A	B	C	A	B	C	A	B	C
12 (305)	6 (152)	(Pre)VI-06-60R12												
	9 (228)	(Pre)VI-09-60R12												
	12 (305)	(Pre)VI-12-60R12	18"	10 ³ / ₈ "	12"	18 ¹³ / ₁₆ "	10 ⁷ / ₈ "	12 ⁹ / ₁₆ "	19 ¹¹ / ₁₆ "	11 ³ / ₈ "	13 ¹ / ₈ "	20 ⁹ / ₁₆ "	11 ⁷ / ₈ "	13 ¹¹ / ₁₆ "
	18 (457)	(Pre)VI-18-60R12	(457)	(263)	(305)	(478)	(276)	(319)	(500)	(289)	(333)	(522)	(301)	(347)
	24 (609)	(Pre)VI-24-60R12												
	30 (762)	(Pre)VI-30-60R12												
24 (609)	6 (152)	(Pre)VI-06-60R24												
	9 (228)	(Pre)VI-09-60R24												
	12 (305)	(Pre)VI-12-60R24	28 ³ / ₈ "	16 ³ / ₈ "	18 ¹⁵ / ₁₆ "	29 ¹ / ₄ "	16 ⁷ / ₈ "	19 ¹ / ₂ "	30 ¹ / ₁₆ "	17 ³ / ₈ "	20 ¹ / ₁₆ "	30 ¹⁵ / ₁₆ "	17 ⁷ / ₈ "	20 ⁵ / ₈ "
	18 (457)	(Pre)VI-18-60R24	(721)	(416)	(481)	(743)	(428)	(495)	(763)	(441)	(509)	(786)	(454)	(524)
	24 (609)	(Pre)VI-24-60R24												
	30 (762)	(Pre)VI-30-60R24												
	36 (914)	(Pre)VI-36-60R24												

60° Vertical Inside (VO) Bend

Bend Radius R in. (mm)	Width in. (mm)	Catalog No.	Siderail Height 4"-7"		
			A	B	C
12 (305)	6 (152)	(Pre)VO-06-60R12			
	9 (228)	(Pre)VO-09-60R12			
	12 (305)	(Pre)VO-12-60R12	14 ⁷ / ₈ "	8 ⁵ / ₈ "	9 ¹⁵ / ₁₆ "
	18 (457)	(Pre)VO-18-60R12	(378)	(219)	(252)
	24 (609)	(Pre)VO-24-60R12			
	30 (762)	(Pre)VO-30-60R12			
24 (609)	6 (152)	(Pre)VO-06-60R24			
	9 (228)	(Pre)VO-09-60R24			
	12 (305)	(Pre)VO-12-60R24	25 ⁵ / ₁₆ "	14 ⁵ / ₈ "	16 ⁷ / ₈ "
	18 (457)	(Pre)VO-18-60R24	(643)	(371)	(428)
	24 (609)	(Pre)VO-24-60R24			
	30 (762)	(Pre)VO-30-60R24			
	36 (914)	(Pre)VO-36-60R24			

(Pre) See page F-21 for catalog number prefix.
Manufacturing tolerances apply to all dimensions.

All dimensions in parentheses are millimeters unless otherwise specified.

Vertical Bend 45° (VO, VI)

1 pair splice plates with hardware included.

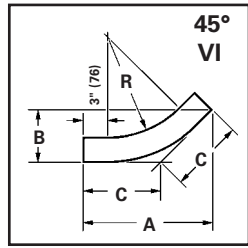

45° Vertical Inside

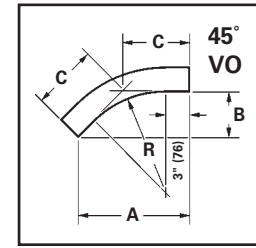
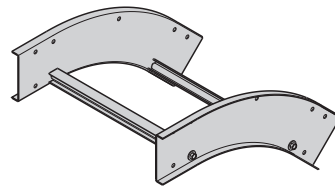
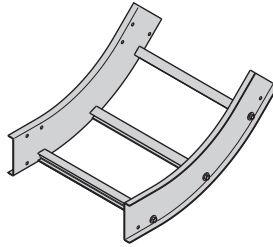

45° Vertical Outside

45° Vertical Inside (VI) Bend

Bend Radius R in. (mm)	Width in. (mm)	Catalog No.	Siderail Height											
			4"			5"			6"			7"		
			A	B	C	A	B	C	A	B	C	A	B	C
12 (305)	6 (152)	(Pre)VI-06-45R12												
	9 (228)	(Pre)VI-09-45R12												
	12 (305)	(Pre)VI-12-45R12	16 ¹ / ₈ "	6 ¹ / ₁₆ "	9 ⁷ / ₁₆ "	16 ⁷ / ₈ "	7"	9 ⁷ / ₈ "	17 ⁹ / ₁₆ "	7 ¹ / ₄ "	10 ¹ / ₄ "	18 ¹ / ₄ "	7 ⁹ / ₁₆ "	10 ¹¹ / ₁₆ "
	18 (457)	(Pre)VI-18-45R12	(409)	(170)	(239)	(428)	(178)	(251)	(446)	(184)	(260)	(463)	(192)	(271)
	24 (609)	(Pre)VI-24-45R12												
	36 (914)	(Pre)VI-36-45R12												
24 (609)	6 (152)	(Pre)VI-06-45R24												
	9 (228)	(Pre)VI-09-45R24												
	12 (305)	(Pre)VI-12-45R24	24 ⁵ / ₈ "	10 ³ / ₁₆ "	14 ⁷ / ₁₆ "	25 ⁵ / ₁₆ "	10 ¹ / ₂ "	14 ¹³ / ₁₆ "	26"	10 ³ / ₄ "	15 ¹ / ₄ "	26 ³ / ₄ "	11 ¹ / ₁₆ "	15 ⁵ / ₈ "
	18 (457)	(Pre)VI-18-45R24	(625)	(259)	(366)	(643)	(267)	(376)	(660)	(273)	(387)	(679)	(281)	(397)
	24 (609)	(Pre)VI-24-45R24												
	36 (914)	(Pre)VI-36-45R24												

45° Vertical Inside (VO) Bend

Bend Radius R in. (mm)	Width in. (mm)	Catalog No.	Siderail Height 4"-7"		
			A	B	C
12 (305)	6 (152)	(Pre)VO-06-45R12			
	9 (228)	(Pre)VO-09-45R12			
	12 (305)	(Pre)VO-12-45R12	13 ⁵ / ₈ "	5 ⁵ / ₈ "	8"
	18 (457)	(Pre)VO-18-45R12	(346)	(136)	(203)
	24 (609)	(Pre)VO-24-45R12			
	36 (914)	(Pre)VO-36-45R12			
24 (609)	6 (152)	(Pre)VO-06-45R24			
	9 (228)	(Pre)VO-09-45R24			
	12 (305)	(Pre)VO-12-45R24	22 ¹ / ₈ "	14 ³ / ₁₆ "	12 ¹⁵ / ₁₆ "
	18 (457)	(Pre)VO-18-45R24	(562)	(233)	(328)
	24 (609)	(Pre)VO-24-45R24			
	36 (914)	(Pre)VO-36-45R24			

(Pre) See page F-21 for catalog number prefix.
Manufacturing tolerances apply to all dimensions.

All dimensions in parentheses are millimeters unless otherwise specified.

Vertical Bend 30° (VO, VI)

1 pair splice plates with hardware included.

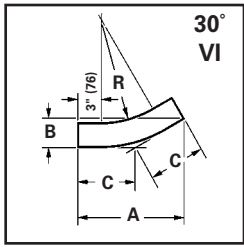

30° Vertical Inside

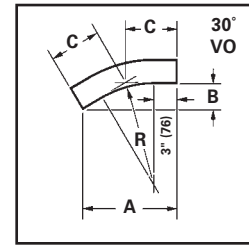
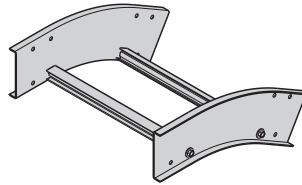
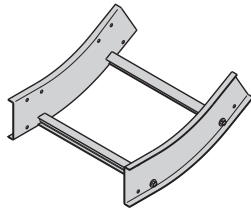

30° Vertical Outside

30° Vertical Inside (VI) Bend

Bend Radius R in. (mm)	Width in. (mm)	Catalog No.	Siderail Height											
			4"			5"			6"			7"		
			A	B	C	A	B	C	A	B	C	A	B	C
12 (305)	6 (152)	(Pre)VI-06-30R12												
	9 (228)	(Pre)VI-09-30R12												
	12 (305)	(Pre)VI-12-30R12	13 ⁷ / ₁₆ "	3 ⁵ / ₈ "	7 ³ / ₁₆ "	13 ¹⁵ / ₁₆ "	3 ³ / ₄ "	7 ⁷ / ₁₆ "	14 ⁷ / ₁₆ "	3 ⁷ / ₈ "	7 ³ / ₄ "	14 ⁷ / ₈ "	4"	8"
	18 (457)	(Pre)VI-18-30R12	(341)	(92)	(182)	(354)	(95)	(189)	(366)	(98)	(197)	(378)	(101)	(203)
	24 (609)	(Pre)VI-24-30R12												
	30 (762)	(Pre)VI-30-30R12												
24 (609)	6 (152)	(Pre)VI-06-30R24												
	9 (228)	(Pre)VI-09-30R24												
	12 (305)	(Pre)VI-12-30R24	19 ⁷ / ₁₆ "	5 ³ / ₁₆ "	10 ⁷ / ₁₆ "	19 ¹⁵ / ₁₆ "	5 ⁵ / ₁₆ "	10 ¹¹ / ₁₆ "	20 ⁷ / ₁₆ "	5 ⁷ / ₁₆ "	10 ¹⁵ / ₁₆ "	20 ⁷ / ₈ "	5 ⁵ / ₈ "	11 ³ / ₁₆ "
	18 (457)	(Pre)VI-18-30R24	(493)	(132)	(265)	(506)	(135)	(271)	(519)	(138)	(278)	(530)	(143)	(284)
	24 (609)	(Pre)VI-24-30R24												
	30 (762)	(Pre)VI-30-30R24												
	36 (914)	(Pre)VI-36-30R24												

30° Vertical Inside (VO) Bend

Bend Radius R in. (mm)	Width in. (mm)	Catalog No.	Siderail Height 4"-7"		
			A	B	C
12 (305)	6 (152)	(Pre)VO-06-30R12			
	9 (228)	(Pre)VO-09-30R12			
	12 (305)	(Pre)VO-12-30R12	11 ⁵ / ₈ "	3 ¹ / ₈ "	6 ¹ / ₄ "
	18 (457)	(Pre)VO-18-30R12	(295)	(79)	(159)
	24 (609)	(Pre)VO-24-30R12			
	30 (762)	(Pre)VO-30-30R12			
24 (609)	6 (152)	(Pre)VO-06-30R24			
	9 (228)	(Pre)VO-09-30R24			
	12 (305)	(Pre)VO-12-30R24	17 ⁵ / ₈ "	4 ³ / ₄ "	9 ⁷ / ₁₆ "
	18 (457)	(Pre)VO-18-30R24	(447)	(120)	(239)
	24 (609)	(Pre)VO-24-30R24			
	30 (762)	(Pre)VO-30-30R24			
	36 (914)	(Pre)VO-36-30R24			

(Pre) See page F-21 for catalog number prefix.
Manufacturing tolerances apply to all dimensions.

All dimensions in parentheses are millimeters unless otherwise specified.

Vertical Tee Up/Down (VTU/VTD)

2 pair splice plates with hardware included.

REDI-RAIL

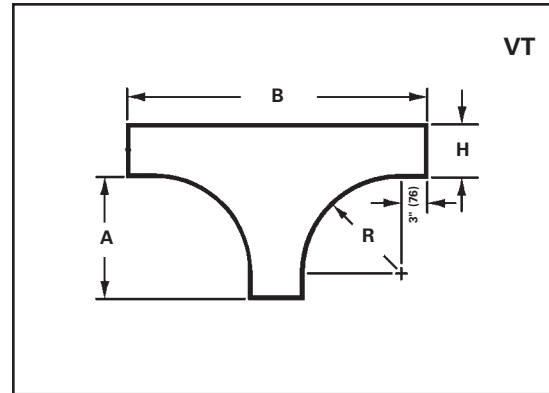
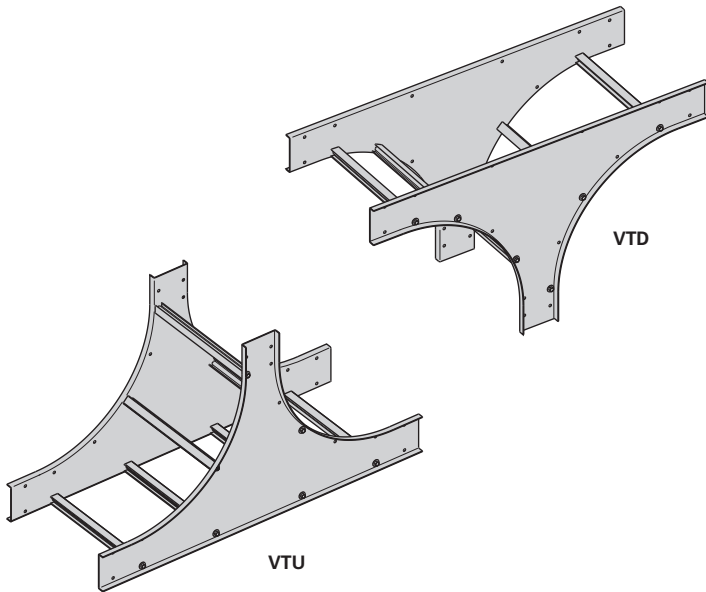

Bend Radius R in. (mm)	Tray Width in. (mm)	(*) Insert U for Tee Up Insert D for Tee Down Catalog No.	Side Rail Height "H"				
			4" - 7"	4"	5"	6"	7"
			A in. (mm)	B in. (mm)	B in. (mm)	B in. (mm)	B in. (mm)
12" (305)	6 (152)	(Prefix)VT(*)-06-R12	15 (381)	33 ⁷ / ₁₆ (849)	34 ³ / ₈ (874)	35 ³ / ₈ (899)	36 ³ / ₈ (924)
	9 (228)	(Prefix)VT(*)-09-R12					
	12 (305)	(Prefix)VT(*)-12-R12					
	18 (457)	(Prefix)VT(*)-18-R12					
	24 (609)	(Prefix)VT(*)-24-R12					
	30 (762)	(Prefix)VT(*)-30-R12					
	36 (914)	(Prefix)VT(*)-36-R12					
24" (609)	6 (152)	(Prefix)VT(*)-06-R24	27 (686)	57 ⁷ / ₁₆ (1458)	58 ³ / ₈ (1483)	59 ³ / ₈ (1508)	60 ³ / ₈ (1533)
	9 (228)	(Prefix)VT(*)-09-R24					
	12 (305)	(Prefix)VT(*)-12-R24					
	18 (457)	(Prefix)VT(*)-18-R24					
	24 (609)	(Prefix)VT(*)-24-R24					
	30 (762)	(Prefix)VT(*)-30-R24					
	36 (914)	(Prefix)VT(*)-36-R24					

(Prefix) See page F-21 for catalog number prefix.
Manufacturing tolerances apply to all dimensions.

All dimensions in parentheses are millimeters unless otherwise specified.

Lined area for notes.