

Channel Cable Tray - Straight Sections

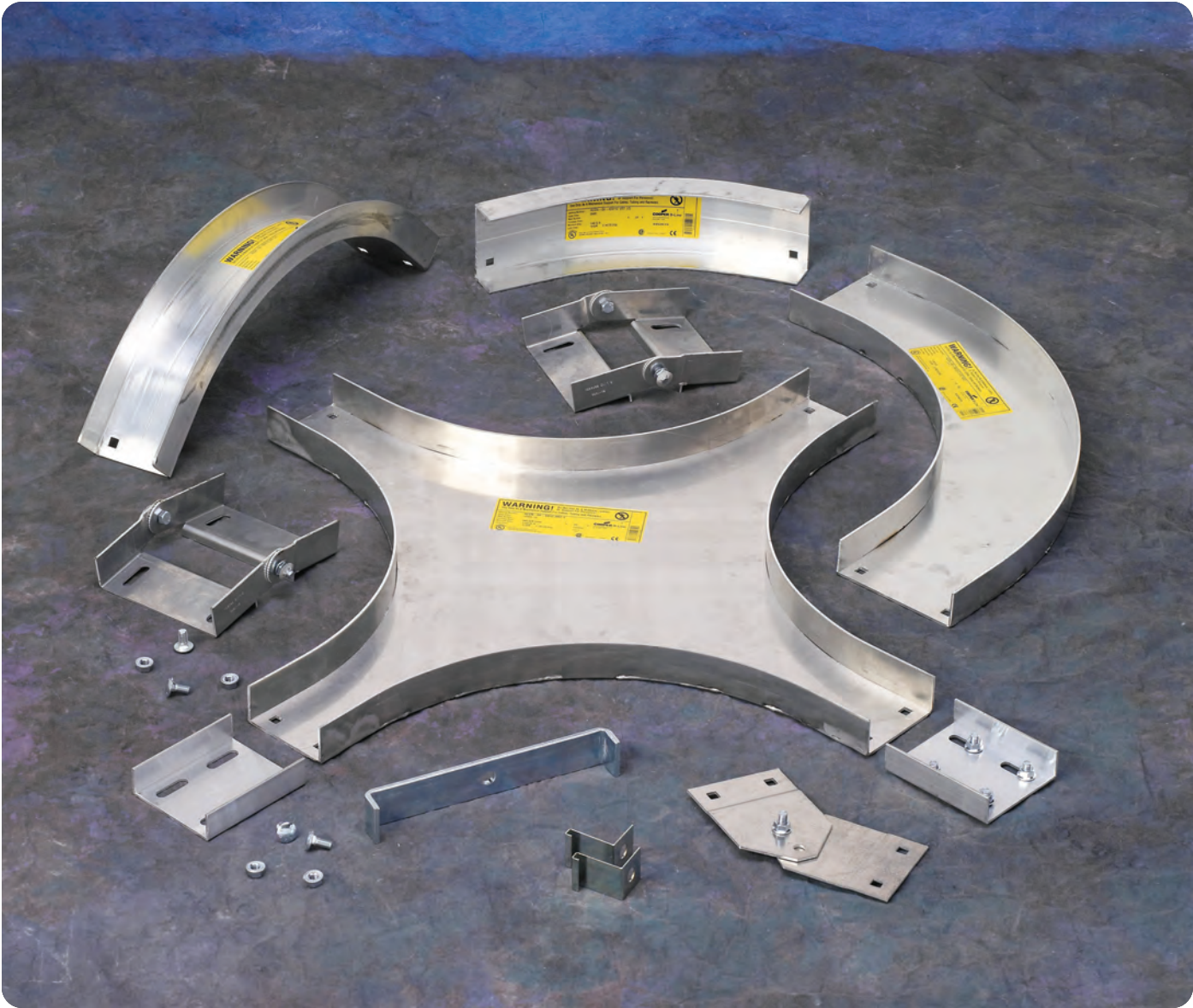

Cable Channel



How The Service Advisor Works

We know that your time is important! That's why the color-coding system in this catalog is designed to help you select products that fit your service needs. Products are marked to indicate the typical lead time for orders of 50 pieces or less.

Customer: How do I select my cable channel product so that I get the quickest turnaround?

Service Advisor: Each part of our selection chart is shown in colors. If any section of a part number is a different color, the part will typically ship with the longer lead time represented by the colors.

- Green = Fastest shipped items
- Black = Normal lead-time items
- Red = Normally long lead-time items

Example: **A** **CC** **03** **-** **144**
 ● ● ● ●

Part will have a normal lead time because of the 03 width.

Changing the part number to 04 width instead of 03 will reduce the lead time.

Channel Cable Tray - Straight Sections

Straight Section Part Numbering

Prefix
Example: **A CC - 04 - 120**

Material

- **A** = Aluminum 6063-T4
- **G** = Type 1 - HDGAF
- **P** = Type 2 - Pre-Galvanized
- **SS4** = 304 Stainless Steel
- **SS6** = 316 Stainless Steel

Type

- **CC** = Ventilated Cable Channel
- **CCN** = Non-Ventilated Cable Channel

Width

- **03** = 3"
- **04** = 4"
- **06** = 6"

Length

- ^① **144** = 12 ft.
- ^② **120** = 10 ft.

① Primary Length.
② Secondary Length.

See page C-23 for explanation of lengths.

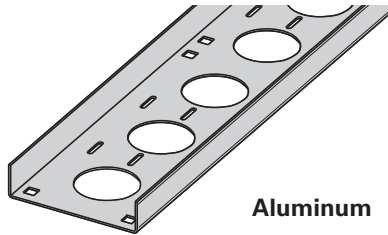

Aluminum

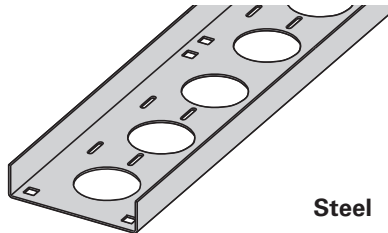

Steel

Ventilated

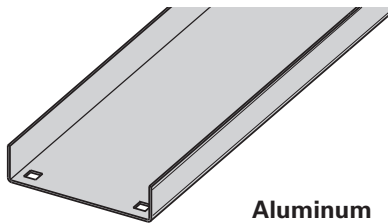

Aluminum

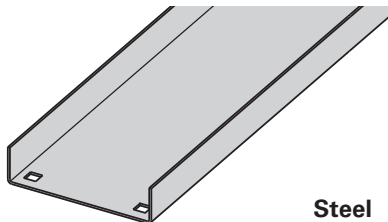

Steel

Non-Ventilated

ACC & ACCN03

3" (75mm) wide
1 1/4" (32mm) deep



ACC & ACCN04

4" (100mm) wide
1 3/4" (44mm) deep



ACC & ACCN06

6" (150mm) wide
1 3/4" (44mm) deep



PCC & PCCN03 SS4CC & SS4CCN03 SS6CC & SS6CCN03

3" (75mm) wide
1 1/4" (32mm) deep



PCC & PCCN04 SS4CC & SS4CCN04 SS6CC & SS6CCN04

4" (100mm) wide
1 3/4" (44mm) deep



PCC & PCCN06 SS4CC & SS4CCN06 SS6CC & SS6CCN06

6" (150mm) wide
1 3/4" (44mm) deep

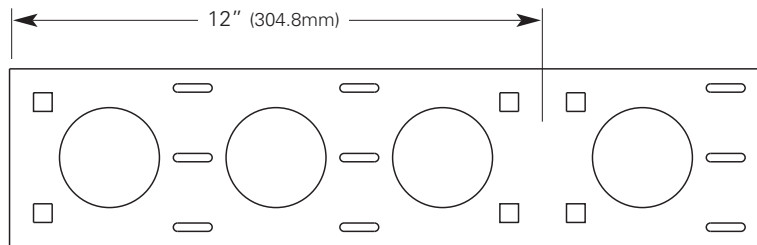

4" wide pattern shown

Ventilated straight sections contain 2 1/4" (57.1mm) diameter holes and 3/16" (4.7mm) x 7/8" (22.2mm) slots for cable attachment. Ventilated straight sections also have splice holes repeating every 12" (304.8mm) to simplify field modifications.

● Green = Fastest shipped items ● Black = Normal lead-time items ● Red = Normally long lead-time items

Channel Cable Tray - Straight Sections

Tray Data & Loading

Material Type	Tray Series	Width		Depth		UL Cross-Sectional Area	Span		Loading			
		in.	(mm)	in.	(mm)		ft.	(m)	lbs/ft	Deflection Multiplier	(kg/m)	Deflection Multiplier
Aluminum Ventilated	ACC-03	3	(76)	1 1/4	(32)	0.40 in ²	5	(1.5)	17	0.020	(26)	0.350
							6	(1.8)	12	0.042	(18)	0.720
							10	(3.0)	4	0.326	(6)	5.600
							12	(3.7)	3	0.676	(4)	12.000
Aluminum Ventilated	ACC-04	4	(101)	1 3/4	(44)	0.60 in ²	5	(1.5)	46	0.007	(69)	0.130
							6	(1.8)	32	0.015	(48)	0.260
							10	(3.0)	12	0.118	(17)	2.000
							12	(3.7)	8	0.244	(12)	4.200
Aluminum Ventilated	ACC-06	6	(152)	1 3/4	(44)	0.60 in ²	5	(1.5)	60	0.006	(90)	0.110
							6	(1.8)	42	0.013	(62)	0.230
							10	(3.0)	15	0.102	(22)	1.700
							12	(3.7)	10	0.211	(16)	3.600
Aluminum Non-Ventilated	ACCN-03	3	(76)	1 1/4	(32)	0.40 in ²	5	(1.5)	23	0.020	(34)	0.350
							6	(1.8)	16	0.042	(24)	0.720
							10	(3.0)	6	0.326	(9)	5.600
							12	(3.7)	4	0.676	(6)	12.000
Aluminum Non-Ventilated	ACCN-04	4	(101)	1 3/4	(44)	0.60 in ²	5	(1.5)	46	0.007	(69)	0.130
							6	(1.8)	32	0.015	(48)	0.260
							10	(3.0)	12	0.118	(17)	2.000
							12	(3.7)	8	0.244	(12)	4.200
Aluminum Non-Ventilated	ACCN-06	6	(152)	1 3/4	(44)	0.60 in ²	5	(1.5)	60	0.006	(90)	0.110
							6	(1.8)	42	0.013	(62)	0.230
							10	(3.0)	15	0.102	(22)	1.700
							12	(3.7)	10	0.211	(16)	3.600
Steel & Stainless Steel Ventilated	PCC-03 SS4CC-03 SS6CC-03	3	(76)	1 1/4	(32)	0.20 in ²	5	(1.5)	24	0.013	(36)	0.220
							6	(1.8)	17	0.028	(25)	0.480
							10	(3.0)	6	0.216	(9)	3.700
							12	(3.7)	4	0.447	(6)	7.600
Steel & Stainless Steel Ventilated	PCC-04 SS4CC-04 SS6CC-04	4	(101)	1 3/4	(44)	0.40 in ²	5	(1.5)	52	0.0039	(77)	0.070
							6	(1.8)	36	0.0082	(54)	0.140
							10	(3.0)	13	0.063	(19)	1.100
							12	(3.7)	9	0.130	(13)	2.200
Steel & Stainless Steel Ventilated	PCC-06 SS4CC-06 SS6CC-06	6	(152)	1 3/4	(44)	0.40 in ²	5	(1.5)	59	0.003	(88)	0.050
							6	(1.8)	41	0.0063	(61)	0.110
							10	(3.0)	15	0.049	(22)	0.840
							12	(3.7)	10	0.101	(15)	1.700
Steel & Stainless Steel Non-Ventilated	PCCN-03 SS4CCN-03 SS6CCN-03	3	(76)	1 1/4	(32)	0.20 in ²	5	(1.5)	24	0.013	(36)	0.220
							6	(1.8)	17	0.028	(25)	0.480
							10	(3.0)	6	0.216	(9)	3.700
							12	(3.7)	4	0.447	(6)	7.600
Steel & Stainless Steel Non-Ventilated	PCCN-04 SS4CCN-04 SS6CCN-04	4	(101)	1 3/4	(44)	0.40 in ²	5	(1.5)	52	0.0039	(77)	0.070
							6	(1.8)	36	0.0082	(54)	0.140
							10	(3.0)	13	0.063	(19)	1.100
							12	(3.7)	9	0.130	(13)	2.200
Steel & Stainless Steel Non-Ventilated	PCCN-06 SS4CCN-06 SS6CCN-06	6	(152)	1 3/4	(44)	0.40 in ²	5	(1.5)	59	0.003	(88)	0.050
							6	(1.8)	41	0.0063	(61)	0.110
							10	(3.0)	15	0.049	(22)	0.840
							12	(3.7)	10	0.101	(15)	1.700

Channel Cable Tray - Accessories

Splice Plate

The Splice Plate has the standard 4-hole pattern for all cable channel.

- Provided with straight sections and fittings.
- Furnished as one plate with hardware.
- (*) Insert **A** **G** **P** **SS4** **SS6**

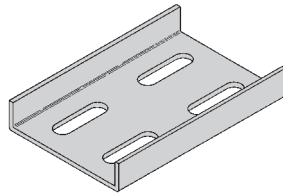

Catalog No.	Channel Width	
	in.	(mm)
9(*)-1043	3	(76)
9(*)-1044	4	(101)
9(*)-1044-6	6	(152)

Horizontal Adjustable Splice Plate

The Horizontal Adjustable Splice Plate adapts to changes in direction in a horizontal plane, beyond the capability of the standard horizontal fittings.

- Furnished as one plate with hardware.
- (*) Insert **A** **G** **P** **SS4** **SS6**

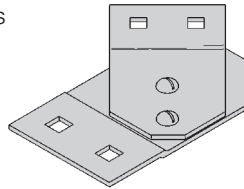

Requires supports within 24" on both sides, per NEMA VE 2.

Catalog No.	Channel Width	
	in.	(mm)
9(*)-1743	3	(76)
9(*)-1744	4	(101)
9(*)-1746	6	(152)

Box Connector

The Box Connector is used to attach the end of a cable channel run to a distribution box or a control center.

- Furnished as one connector with hardware.
- (*) Insert **A** **G** **P** **SS4** **SS6**

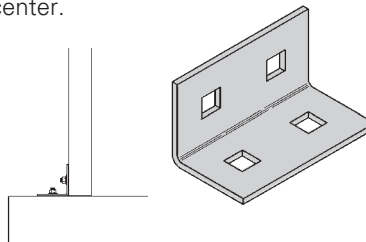

Catalog No.	Channel Width	
	in.	(mm)
9(*)-1543	3	(76)
9(*)-1544	4	(101)
9(*)-1546	6	(152)

Channel Reducer Plate

The Channel Reducer Plate is used to join cable channel sections of different widths.

- Furnished as one plate with hardware.
- (*) Insert **A** **G** **P** **SS4** **SS6**

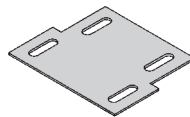

Catalog No.	Channel Width	
	in.	(mm)
9(*)-1843	4 to 3	(101 to 76)
9(*)-1863	6 to 3	(152 to 76)
9(*)-1864	6 to 4	(152 to 101)

Blind End Plate

The Blind End Plate forms a closure for any cable channel dead end.

- Furnished as one plate with hardware.
- (*) Insert **A** **G** **P** **SS4** **SS6**

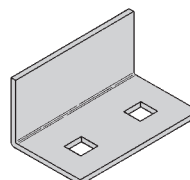

Catalog No.	Channel Width	
	in.	(mm)
9(*)-1583	3	(76)
9(*)-1584	4	(101)
9(*)-1586	6	(152)

● Green = Fastest shipped items ● Black = Normal lead-time items ● Red = Normally long lead-time items

All dimensions in shaded areas are millimeters unless otherwise specified.

Vertical Adjustable Splice Plate

The Adjustable Splice Plate allows changes in elevation where standard vertical fittings are not applicable.

- Furnished as one plate with hardware.
- (*) Insert **A G P SS4 SS6**

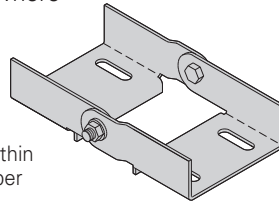

Requires supports within 24" on both sides, per NEMA VE 2.

Catalog No.	Channel Width	
	in.	(mm)
9(*)-1643	3	(76)
9(*)-1644	4	(101)
9(*)-1646	6	(152)

Channel To Tray or Channel To Channel Connector

The Channel Connector is used to link a cable channel to a cable tray, or a cable channel to cable channel.

- Furnished as one plate with hardware.
- (*) Insert **A G P SS4 SS6**

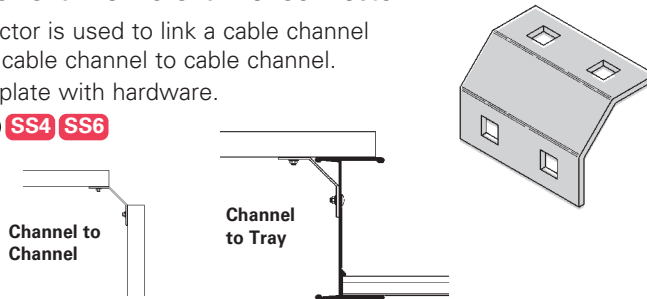

Catalog No.	Channel Width	
	in.	(mm)
9(*)-1261-3	3	(76)
9(*)-1261-4	4	(101)
9(*)-1261-6	6	(152)

Mounting Bracket - Channel To Tray

The Mounting Bracket allows a parallel run of cable channel to be attached to the side of a cable tray. It can also serve as a support splice connection.

- Furnished as one bracket.
- Order hardware separately.
- (*) Insert **A G ZN SS4 SS6**

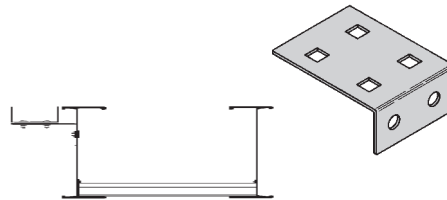

Catalog No.	Channel Width	
	in.	(mm)
9(*)-1237-3	3	(76)
9(*)-1237-4	4	(101)
9(*)-1237-6	6	(152)

Expansion Guide Clamp

The Expansion Guide Clamp allows cable channel to expand and contract in the horizontal plane, but not in the transverse plane.

- Furnished as one clamp.
- Order 1/2" hardware separately.
- (*) Insert **A G ZN SS4 SS6**

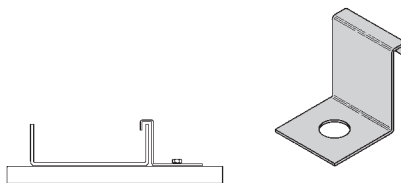

Catalog No.	Channel Width	
	in.	(mm)
9(*)-1243	3	(76)
9(*)-1244	4	(101)
9(*)-1244	6	(152)

Hold-Down Clamp

The Hold-Down Clamp secures cable channel to a support member.

- Furnished as one clamp.
- Order 1/2" hardware separately.
- (*) Insert **A G ZN SS4 SS6**

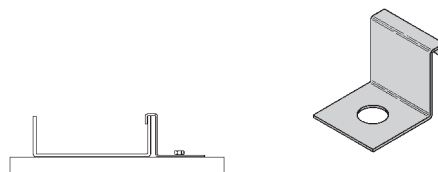

Catalog No.	Channel Width	
	in.	(mm)
9(*)-1245	3	(76)
9(*)-1246	4	(101)
9(*)-1246	6	(152)

● Green = Fastest shipped items ● Black = Normal lead-time items ● Red = Normally long lead-time items

All dimensions in shaded areas are millimeters unless otherwise specified.

Channel Cable Tray - Accessories

Channel To Floor Base Plate

The Channel to Floor Base Plate is used to attach the end of a cable channel run to the floor or to an equipment mounting pad.

- Anchors and hardware are ordered separately.
- (*) Insert **A** **G** **ZN** **SS4** **SS6**

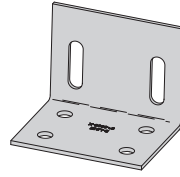

Catalog No.	Channel Width	
	in.	(mm)
9(*)-3305-3	3	(76)
9(*)-3305-4	4	(101)
9(*)-3305-6	6	(152)

Cable Channel Bushing

The Cable Channel Bushing is a snap-in plastic bushing used to protect cable insulation from mechanical wear.

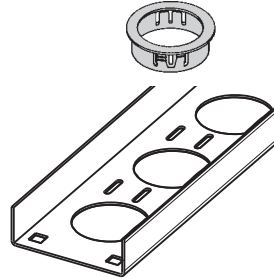

Catalog No.
99-1125

Cable Channel Bracket

- Uniform Load: 225 lbs (1.00 kN) Safety Factor of 2.5
- Finishes available: **ZN** **G**

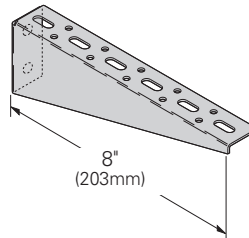

Catalog No.	Channel Width	
	in.	(mm)
B185CCL	3 to 6	(76 to 152)

Cable Channel Bracket

- Safety Factor of 2.5
- Finishes available: **ZN** **G** **GRN**

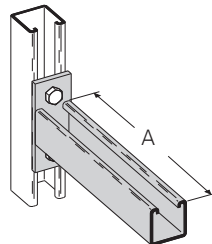

Catalog No.	Channel Width		Uniform Load		A	
	in.	(mm)	lbs	(kN)	in.	(mm)
B409-6	3	(76)	1920	(8.54)	6	(152)
B409-9	4, 6	(101, 152)	1280	(5.69)	9	(228)

Cable Channel Hanger

Designed for 1/2" threaded rod, double nut installation

Single Cable Channel Hanger and Wall Mount

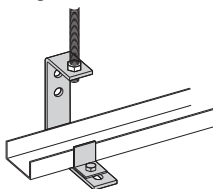

150 lb.
Safety Factor 3.0

Material	Channel Width		
	in. (mm)	in. (mm)	in. (mm)
	3 (76)	4 (101)	6 (152)
Zinc Plated Steel			
Double Channel	● 9ZN-1232-3	● 9ZN-1232-4	● 9ZN-1232-6
Single Channel	● 9ZN-1231-3 & 4	● 9ZN-1231-3 & 4	● 9ZN-1231-6
HDGAF Steel (18 Ga.)			
Double Channel	● 9G-1232-3	● 9G-1232-4	● 9G-1232-6
Single Channel	● 9G-1231-3 & 4	● 9G-1231-3 & 4	● 9G-1231-6

Double Cable Channel Hanger

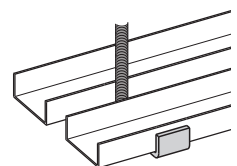

265 lb.
Safety Factor 3.0

● Green = Fastest shipped items ● Black = Normal lead-time items ● Red = Normally long lead-time items

All dimensions in shaded areas are millimeters unless otherwise specified.

Cable Channel Covers

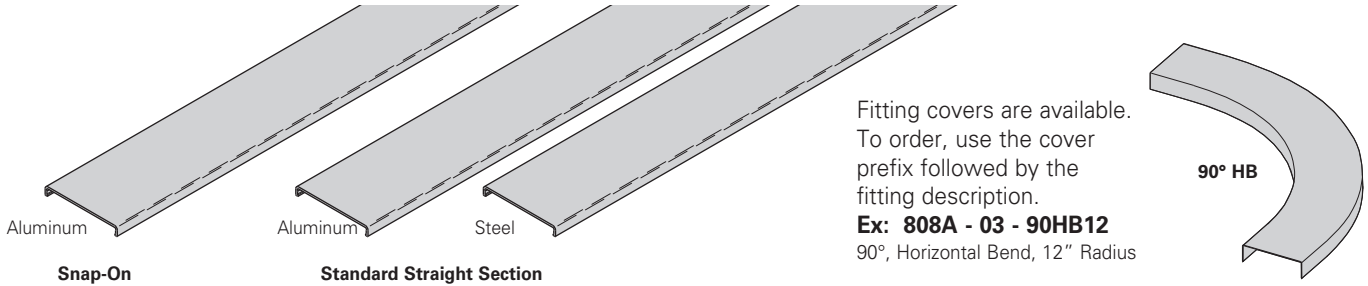

Covers Part Numbering

Prefix
 Example: **80 8 S A - 04 - 144**

Cover Type

80 = Solid

Detail

8 = Flanged

Style

S = Snap-On (Aluminum only*)
 __ = Standard

Material

- A = Aluminum
- G = Type 1 HDGAF
- P = Type 2 Pre-Galvanized
- SS4 = 304 Stainless Steel
- SS6 = 316 Stainless Steel

Tray Width

- 03 = 3"
- 04 = 4"
- 06 = 6"

Item Description

For Straight Section Cover:

Pre-Galv, Aluminum, SS4, & SS6:
 144 = 12 ft.
 120 = 10 ft.
 Pre-Galv, HDGAF, Alum, SS4, & SS6:
 72 = 6 ft.*
 60 = 5 ft.*

Insert suffix of fitting to be covered from the fitting's page.

- _HB_ = Horizontal Bend
- HT_ = Horizontal Tee
- HX_ = Horizontal Cross
- _VI_ = Vertical Inside Bend
- _VO_ = Vertical Outside Bend

All items normal lead time except for those indicated

Material	Length		Channel Width - Straight Section Part Number		
	ft	(m)	in. (mm)	in. (mm)	in. (mm)
● Aluminum (.032) ● Solid	12	3.56m	3 (76)	4 (101)	6 (152)
	10	3.05m	808A-03-144	808A-04-144	808A-06-144
● Type II Pre-Galvanized Steel (20 Ga.) ● Solid	12	3.56m	808A-03-120	808A-04-120	808A-06-120
	10	3.05m	808P-03-144	808P-04-144	808P-06-144
● Type I Hot Dip Galvanized Steel (18 Ga.) ● Solid	12	3.56m	808P-03-120	808P-04-120	808P-06-120
	10	3.05m	808G-03-72	808G-04-72	808G-06-72
			808G-03-60	808G-04-60	808G-06-60

Wrap-Around Cover Clamp

Wrap-Around Cover Clamps are used to securely hold a cover on cable channel in locations where strong winds can prevail.

- Furnished as one clamp with hardware.
- (*) Insert **A G P SS4 SS6**

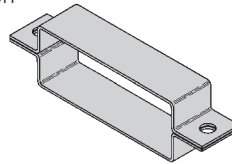

Catalog No.	Channel Width
	in. (mm)
9(*)-9033	3 (76)
9(*)-9034	4 (101)
9(*)-9036	6 (152)

Combination Hold-Down & Cover Clamp

This clamp is used to hold both the cable channel and cover in place at the same time.

- Furnished as one clamp.
- Order 1/4" hardware separately.
- (*) Insert **A G P SS6**

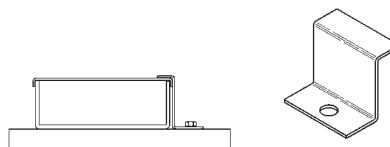

Catalog No.	Channel Width
	in. (mm)
9(*)-9023	3 (76)
9(*)-9024	4 (101)
9(*)-9024	6 (152)

● Green = Fastest shipped items ● Black = Normal lead-time items ● Red = Normally long lead-time items

All dimensions in shaded areas are millimeters unless otherwise specified.

Channel Cable Tray - Accessories

Channel Cable Tray Connectors

Fast, economical, space saving Channel Cable Tray Connectors
 Patent No. 5,628,481; 5,782,439. Other patents pending.

Horizontal:

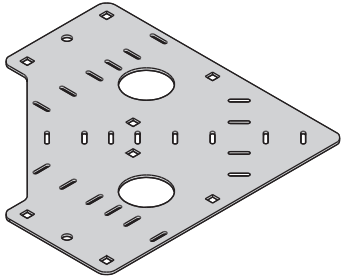

90° Bend

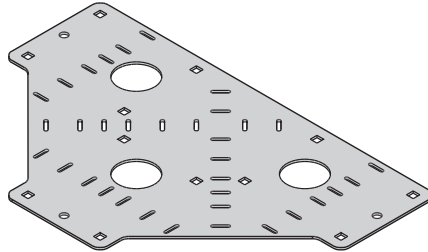

Tee

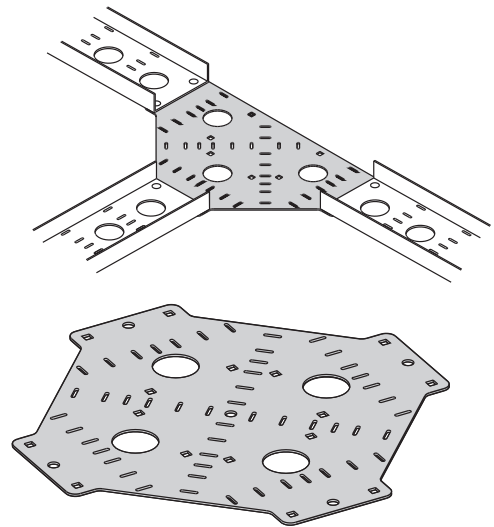

Cross

- Provides 0 or 6-inch radius connection for Cable Channel
- The Pivot Connector is available for custom angle adjustment
 - up to +/- 45° angle adjustment
 - order the desired quantity separately
- Slotted for easy cable fastening
- Shipped with the required hardware

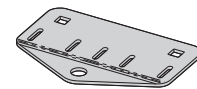

Pivot Connector

Vertical:

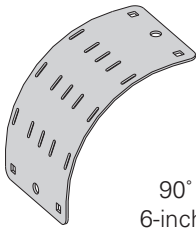

90° Bend
6-inch radius

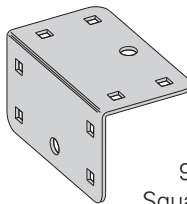

90° Vertical
Square Connector
0-inch radius

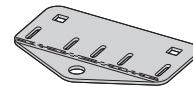

Pivot Connector

- Use the same part for VO and VI applications
- Slotted for easy cable fastening
- The Pivot Connector is available for custom angle adjustment (order separately)
- Shipped with the required hardware

Connector Part Numbering

Prefix
 Example: **A CC - 04 - 90HC 060**

Material

- A = Aluminum
- G = Type 1 HDGAF

Tray Type

CC = Ventilated
Cable Channel

Width

- 03 = 3"
- 04 = 4"
- 06 = 6"

Connector Type

- 90HC = 90° Horizontal
- HTC = Horizontal Tee
- HXC = Horizontal Cross
- 90VC = 90° Vertical
- PC = Pivot Connector

Radius

Horizontal Connectors
 060 = 0" & 6" Radii
Vertical Connectors
 00 = 0" Radius
 06 = 6" Radius

**All items normal lead time
 except for those indicated**

- Green = Fastest shipped items
- Black = Normal lead-time items
- Red = Normally long lead-time items

All dimensions in shaded areas are millimeters unless otherwise specified.

Channel Cable Tray - Fittings

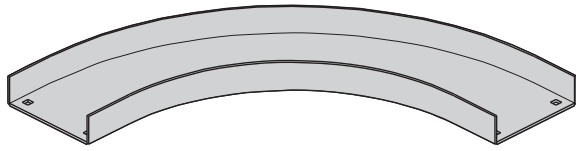

ACCN-04-90HB12
Non-Ventilated Horizontal Bend

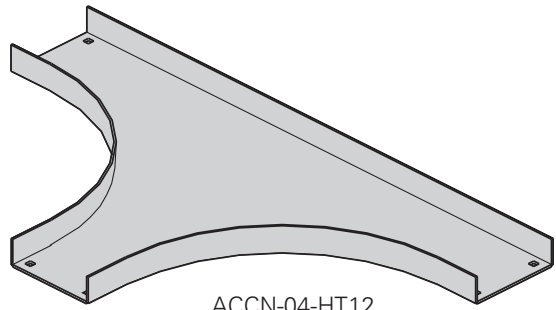

ACCN-04-HT12
Non-Ventilated Tee

Fittings engineered with 3" tangents for splicing integrity.

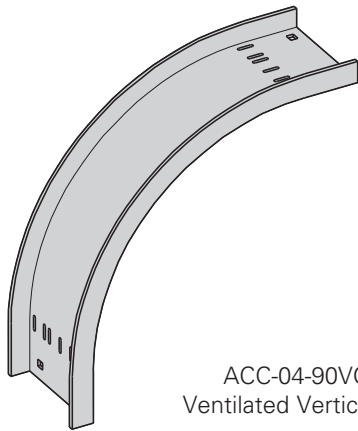

ACC-04-90VO12
Ventilated Vertical Bend

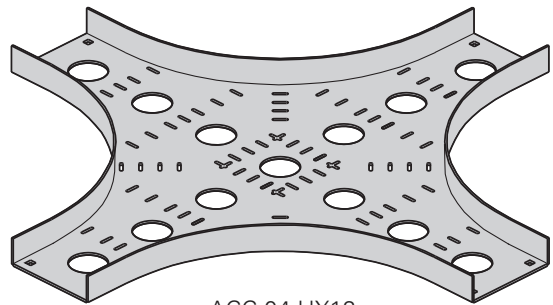

ACC-04-HX12
Ventilated Horizontal Cross

Fittings Part Numbering

Example: ^{Prefix} **A C C N - 04 - 90 H B 24**

Material

Tray Type

Width

Angle

Fitting Type

Radius

- A = Aluminum
- G = Type 1 HDGAF
- SS4 = 304 Stainless Steel
- SS6 = 316 Stainless Steel
- P = †

- *CC = Ventilated Cable Channel
- CCN = Non-ventilated Cable Channel

- 03 = 3"
- 04 = 4"
- 06 = 6"

- 30 = 30°
- 45 = 45°
- 60 = 60°
- 90 = 90°

- HB = Horizontal Bend
- HT = Horizontal Tee
- HX = Horizontal Cross
- VI = Vertical Inside Bend
- VO = Vertical Outside Bend

- 12 = 12"
- 24 = 24"
- 36 = 36"
- 48 = 48"

* Ventilated Cable Channel Fittings are available only in 12" and 24" radii.

† - Due to multiple piece welded construction, P fittings are not available - substitute G.

All items normal lead time except for those indicated

● Green = Fastest shipped items ● Black = Normal lead-time items ● Red = Normally long lead-time items

All dimensions in shaded areas are millimeters unless otherwise specified.

Channel Cable Tray - Fittings

Horizontal Bends 90°, 60° (HB)

1 splice plate with hardware included.

Bend Radius R	Tray Width	90° Horizontal Bend Dimensions			
		Catalog No.	A	B	C
in. (mm)	in. (mm)		in. (mm)	in. (mm)	in. (mm)
12 (305)	3 (76)	(Pre)-03-90HB12	16 ¹ / ₂ (419)	16 ¹ / ₂ (419)	16 ¹ / ₂ (419)
	4 (101)	(Pre)-04-90HB12	17 (432)	17 (432)	17 (432)
	6 (152)	(Pre)-06-90HB12	18 (457)	18 (457)	18 (457)
24 (609)	3 (76)	(Pre)-03-90HB24	28 ¹ / ₂ (723)	28 ¹ / ₂ (723)	28 ¹ / ₂ (723)
	4 (101)	(Pre)-04-90HB24	29 (737)	29 (737)	29 (737)
	6 (152)	(Pre)-06-90HB24	30 (762)	30 (762)	30 (762)
36 (915)	3 (76)	(Pre)-03-90HB36	40 ¹ / ₂ (1029)	40 ¹ / ₂ (1029)	40 ¹ / ₂ (1029)
	4 (101)	(Pre)-04-90HB36	41 (1041)	41 (1041)	41 (1041)
	6 (152)	(Pre)-06-90HB36	42 (1067)	42 (1067)	42 (1067)
48 (1218)	3 (76)	(Pre)-03-90HB48	52 ¹ / ₂ (1334)	52 ¹ / ₂ (1334)	52 ¹ / ₂ (1334)
	4 (101)	(Pre)-04-90HB48	53 (1346)	53 (1346)	53 (1346)
	6 (152)	(Pre)-06-90HB48	54 (1372)	54 (1372)	54 (1372)

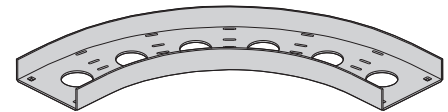

90° Horizontal Bend
Ventilated Horizontal Bend

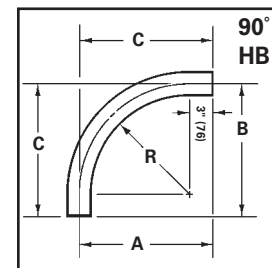

60° Horizontal Bend					
Bend Radius R	Tray Width	Catalog No.	A	B	C
in. (mm)	in. (mm)		in. (mm)	in. (mm)	in. (mm)
12 (305)	3 (76)	(Pre)-03-60HB12	16 ¹ / ₄ (412)	9 ³ / ₈ (239)	10 ³ / ₄ (273)
	4 (101)	(Pre)-04-60HB12	16 ⁵ / ₈ (422)	9 ⁵ / ₈ (245)	11 ¹ / ₈ (283)
	6 (152)	(Pre)-06-60HB12	17 ¹ / ₂ (445)	10 (254)	11 ⁵ / ₈ (296)
24 (609)	3 (76)	(Pre)-03-60HB24	26 ⁵ / ₈ (676)	15 ³ / ₈ (391)	17 ³ / ₄ (451)
	4 (101)	(Pre)-04-60HB24	27 (686)	15 ⁵ / ₈ (397)	18 (450)
	6 (152)	(Pre)-06-60HB24	27 ⁷ / ₈ (708)	16 (406)	18 ⁵ / ₈ (466)
36 (915)	3 (76)	(Pre)-03-60HB36	37 (940)	21 ³ / ₈ (543)	24 ⁵ / ₈ (625)
	4 (101)	(Pre)-04-60HB36	37 ³ / ₈ (949)	21 ⁵ / ₈ (549)	25 (635)
	6 (152)	(Pre)-06-60HB36	38 ¹ / ₄ (972)	22 (559)	25 ¹ / ₂ (648)
48 (1218)	3 (76)	(Pre)-03-60HB48	47 ³ / ₈ (1203)	27 ³ / ₈ (695)	31 ⁵ / ₈ (803)
	4 (101)	(Pre)-04-60HB48	47 ⁷ / ₈ (1216)	27 ⁵ / ₈ (702)	31 ⁷ / ₈ (810)
	6 (152)	(Pre)-06-60HB48	48 ⁵ / ₈ (1235)	28 (711)	32 ¹ / ₂ (826)

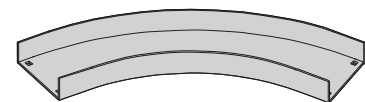

60° Horizontal Bend
Non-Ventilated Horizontal Bend

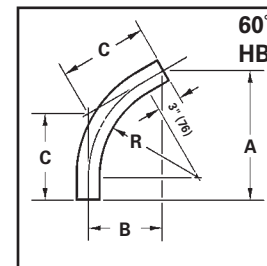

(Pre) See page E-10 for catalog number prefix.

All dimensions in shaded areas are millimeters unless otherwise specified.

Horizontal Bends 45°, 30° (HB)

1 splice plate with hardware included.



45° Horizontal Bend
Ventilated Horizontal Bend

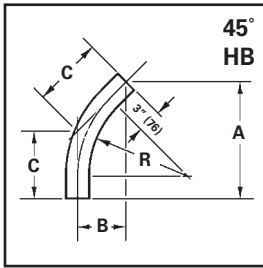

45°
HB



30° Horizontal Bend
Non-Ventilated Horizontal Bend

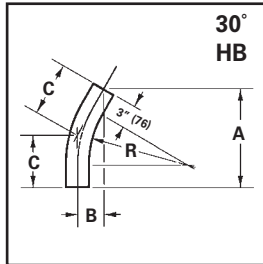

30°
HB

Bend Radius R	Tray Width	45° Horizontal Bend Dimensions			
		Catalog No.	A	B	C
in. (mm)	in. (mm)		in. (mm)	in. (mm)	in. (mm)
12 (305)	3 (76)	(Pre)-03-45HB12	14 ⁵ / ₈ (371)	6 ¹ / ₈ (156)	8 ⁵ / ₈ (219)
	4 (101)	(Pre)-04-45HB12	15 (381)	6 ¹ / ₄ (159)	8 ⁷ / ₈ (225)
	6 (152)	(Pre)-06-45HB12	15 ³ / ₄ (400)	6 ¹ / ₂ (165)	9 ¹ / ₄ (235)
24 (609)	3 (76)	(Pre)-03-45HB24	23 ¹ / ₈ (587)	9 ⁵ / ₈ (244)	13 ⁵ / ₈ (346)
	4 (101)	(Pre)-04-45HB24	23 ¹ / ₂ (597)	9 ³ / ₄ (248)	13 ³ / ₄ (349)
	6 (152)	(Pre)-06-45HB24	24 ¹ / ₈ (613)	10 (254)	14 ¹ / ₈ (359)
36 (915)	3 (76)	(Pre)-03-45HB36	31 ⁵ / ₈ (803)	13 ¹ / ₈ (334)	18 ⁵ / ₈ (473)
	4 (101)	(Pre)-04-45HB36	32 (813)	13 ¹ / ₄ (337)	18 ³ / ₄ (476)
	6 (152)	(Pre)-06-45HB36	32 ³ / ₄ (832)	13 ¹ / ₂ (343)	19 ¹ / ₈ (486)
48 (1218)	3 (76)	(Pre)-03-45HB48	40 ¹ / ₈ (1019)	16 ⁵ / ₈ (422)	23 ¹ / ₂ (597)
	4 (101)	(Pre)-04-45HB48	40 ¹ / ₂ (1029)	16 ³ / ₄ (425)	23 ³ / ₄ (603)
	6 (152)	(Pre)-06-45HB48	41 ¹ / ₈ (1045)	17 (432)	24 ¹ / ₈ (613)

30° Horizontal Bend					
Bend Radius R	Tray Width	Catalog No.	A	B	C
			in. (mm)	in. (mm)	in. (mm)
12 (305)	3 (76)	(Pre)-03-30HB12	12 ³ / ₈ (314)	3 ¹ / ₄ (83)	6 ⁵ / ₈ (168)
	4 (101)	(Pre)-04-30HB12	12 ⁵ / ₈ (321)	3 ³ / ₈ (86)	6 ³ / ₄ (171)
	6 (152)	(Pre)-06-30HB12	13 ¹ / ₈ (334)	3 ¹ / ₂ (89)	7 (178)
24 (609)	3 (76)	(Pre)-03-30HB24	18 ³ / ₈ (467)	4 ⁷ / ₈ (124)	9 ⁷ / ₈ (251)
	4 (101)	(Pre)-04-30HB24	18 ⁵ / ₈ (473)	5 (127)	10 (254)
	6 (152)	(Pre)-06-30HB24	19 ¹ / ₈ (486)	5 ¹ / ₈ (130)	10 ¹ / ₄ (260)
36 (915)	3 (76)	(Pre)-03-30HB36	24 ³ / ₈ (619)	6 ¹ / ₂ (165)	13 (330)
	4 (101)	(Pre)-04-30HB36	24 ⁵ / ₈ (626)	6 ⁵ / ₈ (168)	13 ¹ / ₈ (334)
	6 (152)	(Pre)-06-30HB36	25 ¹ / ₈ (638)	6 ³ / ₄ (171)	13 ¹ / ₂ (343)
48 (1218)	3 (76)	(Pre)-03-30HB48	30 ³ / ₈ (772)	8 ¹ / ₈ (207)	16 ¹ / ₄ (413)
	4 (101)	(Pre)-04-30HB48	30 ⁵ / ₈ (778)	8 ¹ / ₄ (210)	16 ³ / ₈ (416)
	6 (152)	(Pre)-06-30HB48	31 ¹ / ₈ (791)	8 ³ / ₈ (213)	16 ⁵ / ₈ (422)

(Pre) See page E-10 for catalog number prefix.

All dimensions in shaded areas are millimeters unless otherwise specified.

Channel Cable Tray - Fittings

Horizontal Tee (HT)

2 splice plates with hardware included.

Bend Radius R in. (mm)	Tray Width in. (mm)	Horizontal Tee Dimensions		
		Catalog No.	A in. (mm)	B in. (mm)
12 (305)	3 (76)	(Pre)-03-HT12	16 ¹ / ₂ (419)	33 (838)
	4 (101)	(Pre)-04-HT12	17 (432)	34 (864)
	6 (152)	(Pre)-06-HT12	18 (457)	36 (914)
24 (609)	3 (76)	(Pre)-03-HT24	28 ¹ / ₂ (723)	57 (1448)
	4 (101)	(Pre)-04-HT24	29 (737)	58 (1473)
	6 (152)	(Pre)-06-HT24	30 (762)	60 (1524)
36 (915)	3 (76)	(Pre)-03-HT36	40 ¹ / ₂ (1029)	81 (2057)
	4 (101)	(Pre)-04-HT36	41 (1041)	82 (2083)
	6 (152)	(Pre)-06-HT36	42 (1067)	84 (2134)
48 (1218)	3 (76)	(Pre)-03-HT48	52 ¹ / ₂ (1334)	105 (2667)
	4 (101)	(Pre)-04-HT48	53 (1346)	106 (2692)
	6 (152)	(Pre)-06-HT48	54 (1372)	108 (2743)

(Pre) See page E-10 for catalog number prefix.

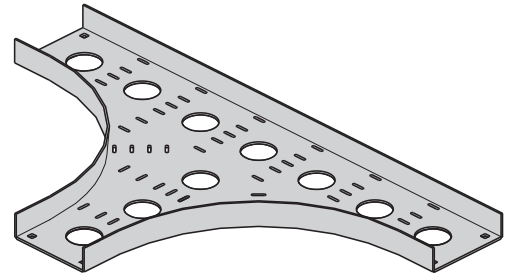

Horizontal Tee
Ventilated Horizontal Tee

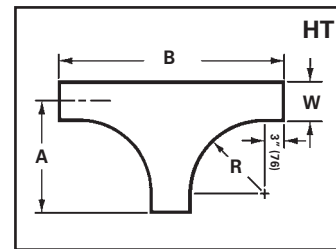

Horizontal Cross (HX)

3 splice plates with hardware included.

Bend Radius R in. (mm)	Tray Width in. (mm)	Horizontal Cross Dimensions		
		Catalog No.	A in. (mm)	B in. (mm)
12 (305)	3 (76)	(Pre)-03-HX12	16 ¹ / ₂ (419)	33 (838)
	4 (101)	(Pre)-04-HX12	17 (432)	34 (864)
	6 (152)	(Pre)-06-HX12	18 (457)	36 (914)
24 (609)	3 (76)	(Pre)-03-HX24	28 ¹ / ₂ (723)	57 (1448)
	4 (101)	(Pre)-04-HX24	29 (737)	58 (1473)
	6 (152)	(Pre)-06-HX24	30 (762)	60 (1524)
36 (915)	3 (76)	(Pre)-03-HX36	40 ¹ / ₂ (1029)	81 (2057)
	4 (101)	(Pre)-04-HX36	41 (1041)	82 (2083)
	6 (152)	(Pre)-06-HX36	42 (1067)	84 (2134)
48 (1218)	3 (76)	(Pre)-03-HX48	52 ¹ / ₂ (1334)	105 (2667)
	4 (101)	(Pre)-04-HX48	53 (1346)	106 (2692)
	6 (152)	(Pre)-06-HX48	54 (1372)	108 (2743)

(Pre) See page E-10 for catalog number prefix.

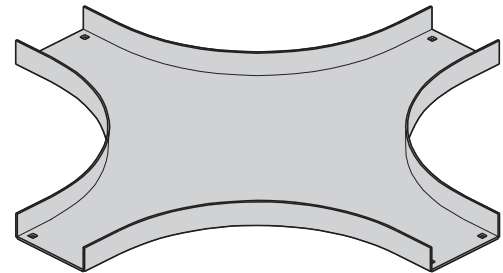

Horizontal Cross
Non-Ventilated Horizontal Cross

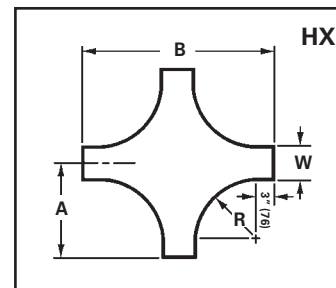

All dimensions in shaded areas are millimeters unless otherwise specified.

Vertical Outside Bends 90°, 60° (VO)

1 splice plate with hardware included.

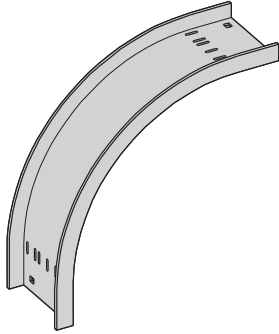

90° Vertical Outside Bend
Ventilated Vertical Outside Bend

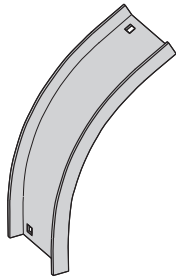
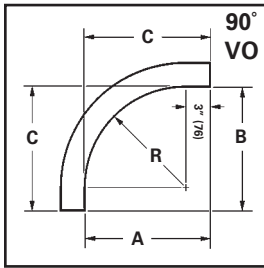

60° Vertical Outside Bend
Non-Ventilated Vertical Outside Bend

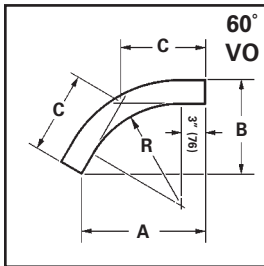

Bend Radius R	Tray Width	90° Vertical Outside Bend Dimensions			
		Catalog No.	A	B	C
in. (mm)	in. (mm)		in. (mm)	in. (mm)	in. (mm)
12 (305)	3 (76)	(Pre)-03-90VO12	15 (381)	15 (381)	15 (381)
	4 (101)	(Pre)-04-90VO12	15 (381)	15 (381)	15 (381)
	6 (152)	(Pre)-06-90VO12	15 (381)	15 (381)	15 (381)
24 (609)	3 (76)	(Pre)-03-90VO24	27 (686)	27 (686)	27 (686)
	4 (101)	(Pre)-04-90VO24	27 (686)	27 (686)	27 (686)
	6 (152)	(Pre)-06-90VO24	27 (686)	27 (686)	27 (686)
36 (915)	3 (76)	(Pre)-03-90VO36	39 (991)	39 (991)	39 (991)
	4 (101)	(Pre)-04-90VO36	39 (991)	39 (991)	39 (991)
	6 (152)	(Pre)-06-90VO36	39 (991)	39 (991)	39 (991)
48 (1218)	3 (76)	(Pre)-03-90VO48	51 (1295)	51 (1295)	51 (1295)
	4 (101)	(Pre)-04-90VO48	51 (1295)	51 (1295)	51 (1295)
	6 (152)	(Pre)-06-90VO48	51 (1295)	51 (1295)	51 (1295)

60° Vertical Outside Bend					
Bend Radius R	Tray Width	Catalog No.	A	B	C
			in. (mm)	in. (mm)	in. (mm)
12 (305)	3 (76)	(Pre)-03-60VO12	14 ⁷ / ₈ (378)	8 ¹ / ₂ (216)	9 ⁷ / ₈ (251)
	4 (101)	(Pre)-04-60VO12	14 ⁷ / ₈ (378)	8 ¹ / ₂ (216)	9 ⁷ / ₈ (251)
	6 (152)	(Pre)-06-60VO12	14 ⁷ / ₈ (378)	8 ¹ / ₂ (216)	9 ⁷ / ₈ (251)
24 (609)	3 (76)	(Pre)-03-60VO24	25 ³ / ₈ (645)	14 ⁵ / ₈ (372)	16 ⁷ / ₈ (428)
	4 (101)	(Pre)-04-60VO24	25 ³ / ₈ (645)	14 ⁵ / ₈ (372)	16 ⁷ / ₈ (428)
	6 (152)	(Pre)-06-60VO24	25 ³ / ₈ (645)	14 ⁵ / ₈ (372)	16 ⁷ / ₈ (428)
36 (915)	3 (76)	(Pre)-03-60VO36	35 ³ / ₈ (905)	20 ⁵ / ₈ (524)	23 ³ / ₄ (603)
	4 (101)	(Pre)-04-60VO36	35 ³ / ₈ (905)	20 ⁵ / ₈ (524)	23 ³ / ₄ (603)
	6 (152)	(Pre)-06-60VO36	35 ³ / ₈ (905)	20 ⁵ / ₈ (524)	23 ³ / ₄ (603)
48 (1218)	3 (76)	(Pre)-03-60VO48	46 ¹ / ₈ (1172)	26 ⁵ / ₈ (676)	30 ³ / ₄ (781)
	4 (101)	(Pre)-04-60VO48	46 ¹ / ₈ (1172)	26 ⁵ / ₈ (676)	30 ³ / ₄ (781)
	6 (152)	(Pre)-06-60VO48	46 ¹ / ₈ (1172)	26 ⁵ / ₈ (676)	30 ³ / ₄ (781)

(Pre) See page E-10 for catalog number prefix.

All dimensions in shaded areas are millimeters unless otherwise specified.

Channel Cable Tray - Fittings

Vertical Outside Bends 45°, 30° (VO)

1 splice plate with hardware included.

Bend Radius R	Tray Width	45° Vertical Outside Bend Dimensions			
		Catalog No.	A	B	C
in. (mm)	in. (mm)		in. (mm)	in. (mm)	in. (mm)
12 (305)	3 (76)	(Pre)-03-45VO12	13 ⁵ / ₈ (346)	5 ⁵ / ₈ (143)	8 (203)
	4 (101)	(Pre)-04-45VO12	13 ⁵ / ₈ (346)	5 ⁵ / ₈ (143)	8 (203)
	6 (152)	(Pre)-06-45VO12	13 ⁵ / ₈ (346)	5 ⁵ / ₈ (143)	8 (203)
24 (609)	3 (76)	(Pre)-03-45VO24	22 ¹ / ₄ (565)	9 ¹ / ₄ (235)	13 (330)
	4 (101)	(Pre)-04-45VO24	22 ¹ / ₄ (565)	9 ¹ / ₄ (235)	13 (330)
	6 (152)	(Pre)-06-45VO24	22 ¹ / ₄ (565)	9 ¹ / ₄ (235)	13 (330)
36 (915)	3 (76)	(Pre)-03-45VO36	30 ¹ / ₂ (775)	12 ⁵ / ₈ (321)	17 ⁷ / ₈ (454)
	4 (101)	(Pre)-04-45VO36	30 ¹ / ₂ (775)	12 ⁵ / ₈ (321)	17 ⁷ / ₈ (454)
	6 (152)	(Pre)-06-45VO36	30 ¹ / ₂ (775)	12 ⁵ / ₈ (321)	17 ⁷ / ₈ (454)
48 (1218)	3 (76)	(Pre)-03-45VO48	39 (991)	16 ¹ / ₈ (410)	22 ⁷ / ₈ (581)
	4 (101)	(Pre)-04-45VO48	39 (991)	16 ¹ / ₈ (410)	22 ⁷ / ₈ (581)
	6 (152)	(Pre)-06-45VO48	39 (991)	16 ¹ / ₈ (410)	22 ⁷ / ₈ (581)

30° Vertical Outside Bend					
Bend Radius R	Tray Width	Catalog No.	A	B	C
in. (mm)	in. (mm)		in. (mm)	in. (mm)	in. (mm)
12 (305)	3 (76)	(Pre)-03-30VO12	11 ⁵ / ₈ (296)	3 ¹ / ₈ (79)	6 ¹ / ₄ (158)
	4 (101)	(Pre)-04-30VO12	11 ⁵ / ₈ (296)	3 ¹ / ₈ (79)	6 ¹ / ₄ (158)
	6 (152)	(Pre)-06-30VO12	11 ⁵ / ₈ (296)	3 ¹ / ₈ (79)	6 ¹ / ₄ (158)
24 (609)	3 (76)	(Pre)-03-30VO24	17 ¹ / ₂ (445)	4 ⁷ / ₈ (124)	9 ³ / ₈ (238)
	4 (101)	(Pre)-04-30VO24	17 ¹ / ₂ (445)	4 ⁷ / ₈ (124)	9 ³ / ₈ (238)
	6 (152)	(Pre)-06-30VO24	17 ¹ / ₂ (445)	4 ⁷ / ₈ (124)	9 ³ / ₈ (238)
36 (915)	3 (76)	(Pre)-03-30VO36	23 ¹ / ₂ (597)	6 ³ / ₈ (162)	12 ⁵ / ₈ (321)
	4 (101)	(Pre)-04-30VO36	23 ¹ / ₂ (597)	6 ³ / ₈ (162)	12 ⁵ / ₈ (321)
	6 (152)	(Pre)-06-30VO36	23 ¹ / ₂ (597)	6 ³ / ₈ (162)	12 ⁵ / ₈ (321)
48 (1218)	3 (76)	(Pre)-03-30VO48	29 ⁵ / ₈ (753)	8 (203)	15 ⁷ / ₈ (403)
	4 (101)	(Pre)-04-30VO48	29 ⁵ / ₈ (753)	8 (203)	15 ⁷ / ₈ (403)
	6 (152)	(Pre)-06-30VO48	29 ⁵ / ₈ (753)	8 (203)	15 ⁷ / ₈ (403)

(Pre) See page E-10 for catalog number prefix.

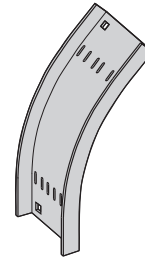

45° Vertical Outside Bend
Ventilated Vertical Outside Bend

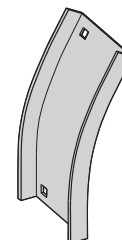
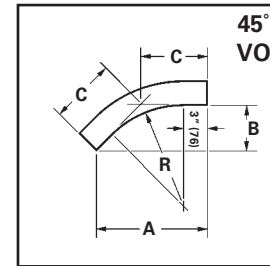

30° Vertical Outside Bend
Non-Ventilated Vertical Outside Bend

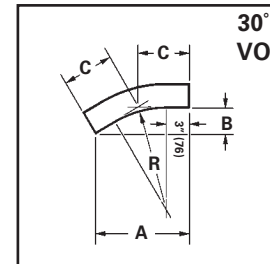

All dimensions in shaded areas are millimeters unless otherwise specified.

Vertical Inside Bends 90°, 60° (VI)

1 splice plate with hardware included.

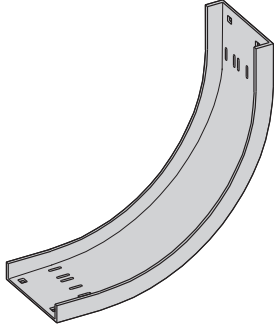

90° Vertical Inside Bend
Ventilated Vertical Inside Bend

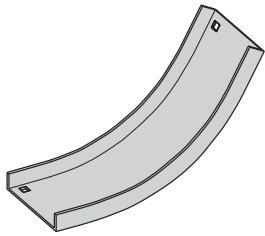
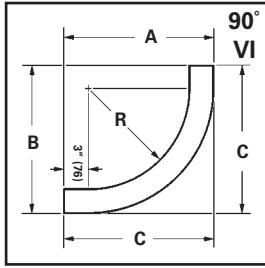

60° Vertical Inside Bend
Non-Ventilated Vertical Inside Bend

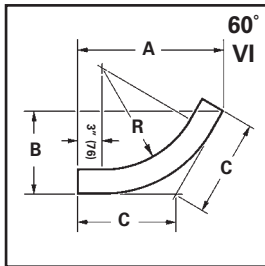

Bend Radius R	Tray Width	90° Vertical Inside Bend Dimensions			
		Catalog No.	A	B	C
in. (mm)	in. (mm)		in. (mm)	in. (mm)	in. (mm)
12 (305)	3 (76)	(Pre)-03-90VI12	16 ¹ / ₄ (413)	16 ¹ / ₄ (413)	16 ¹ / ₄ (413)
	4 (101)	(Pre)-04-90VI12	16 ³ / ₄ (425)	16 ³ / ₄ (425)	16 ³ / ₄ (425)
	6 (152)	(Pre)-06-90VI12	16 ³ / ₄ (425)	16 ³ / ₄ (425)	16 ³ / ₄ (425)
24 (609)	3 (76)	(Pre)-03-90VI24	28 ¹ / ₄ (718)	28 ¹ / ₄ (718)	28 ¹ / ₄ (718)
	4 (101)	(Pre)-04-90VI24	28 ³ / ₄ (730)	28 ³ / ₄ (730)	28 ³ / ₄ (730)
	6 (152)	(Pre)-06-90VI24	28 ³ / ₄ (730)	28 ³ / ₄ (730)	28 ³ / ₄ (730)
36 (915)	3 (76)	(Pre)-03-90VI36	40 ¹ / ₄ (1024)	40 ¹ / ₄ (1024)	40 ¹ / ₄ (1024)
	4 (101)	(Pre)-04-90VI36	40 ³ / ₄ (1035)	40 ³ / ₄ (1035)	40 ³ / ₄ (1035)
	6 (152)	(Pre)-06-90VI36	40 ³ / ₄ (1035)	40 ³ / ₄ (1035)	40 ³ / ₄ (1035)
48 (1218)	3 (76)	(Pre)-03-90VI48	52 ¹ / ₄ (1327)	52 ¹ / ₄ (1327)	52 ¹ / ₄ (1327)
	4 (101)	(Pre)-04-90VI48	52 ³ / ₄ (1340)	52 ³ / ₄ (1340)	52 ³ / ₄ (1340)
	6 (152)	(Pre)-06-90VI48	52 ³ / ₄ (1340)	52 ³ / ₄ (1340)	52 ³ / ₄ (1340)

60° Vertical Inside Bend					
Bend Radius	Tray Width	Catalog No.	A	B	C
in. (mm)	in. (mm)		in. (mm)	in. (mm)	in. (mm)
12 (305)	3 (76)	(Pre)-03-60VI12	16 (406)	9 ¹ / ₄ (235)	10 ⁵ / ₈ (270)
	4 (101)	(Pre)-04-60VI12	16 ¹ / ₂ (419)	9 ¹ / ₂ (241)	11 (280)
	6 (152)	(Pre)-06-60VI12	16 ¹ / ₂ (419)	9 ¹ / ₂ (241)	11 (280)
24 (609)	3 (76)	(Pre)-03-60VI24	26 ¹ / ₂ (673)	15 ¹ / ₄ (387)	17 ⁵ / ₈ (448)
	4 (101)	(Pre)-04-60VI24	26 ⁷ / ₈ (683)	15 ¹ / ₂ (394)	17 ⁷ / ₈ (454)
	6 (152)	(Pre)-06-60VI24	26 ⁷ / ₈ (683)	15 ¹ / ₂ (394)	17 ⁷ / ₈ (454)
36 (915)	3 (76)	(Pre)-03-60VI36	36 ³ / ₄ (933)	21 ¹ / ₄ (540)	24 ¹ / ₂ (622)
	4 (101)	(Pre)-04-60VI36	37 ¹ / ₈ (943)	21 ³ / ₈ (543)	24 ³ / ₄ (629)
	6 (152)	(Pre)-06-60VI36	37 ¹ / ₈ (943)	21 ³ / ₈ (543)	24 ³ / ₄ (629)
48 (1218)	3 (76)	(Pre)-03-60VI48	47 ¹ / ₈ (1197)	27 ¹ / ₈ (689)	31 ³ / ₈ (797)
	4 (101)	(Pre)-04-60VI48	47 ⁵ / ₈ (1210)	27 ¹ / ₂ (699)	31 ³ / ₄ (806)
	6 (152)	(Pre)-06-60VI48	47 ⁵ / ₈ (1210)	27 ¹ / ₂ (699)	31 ³ / ₄ (806)

(Pre) See page E-10 for catalog number prefix.

All dimensions in shaded areas are millimeters unless otherwise specified.

Channel Cable Tray - Fittings

Vertical Inside Bends 45°, 30° (VI)

1 splice plate with hardware included.

Bend Radius R	Tray Width	45° Vertical Inside Bend Dimensions			
		Catalog No.	A	B	C
in. (mm)	in. (mm)		in. (mm)	in. (mm)	in. (mm)
12 (305)	3 (76)	(Pre)-03-45VI12	14 ¹ / ₂ (368)	6 (152)	8 ¹ / ₂ (216)
	4 (101)	(Pre)-04-45VI12	14 ⁷ / ₈ (373)	6 ¹ / ₈ (156)	8 ³ / ₄ (222)
	6 (152)	(Pre)-06-45VI12	14 ⁷ / ₈ (373)	6 ¹ / ₈ (156)	8 ³ / ₄ (222)
24 (609)	3 (76)	(Pre)-03-45VI24	23 (584)	9 ¹ / ₂ (241)	13 ¹ / ₂ (343)
	4 (101)	(Pre)-04-45VI24	23 ¹ / ₄ (591)	9 ⁵ / ₈ (245)	13 ⁵ / ₈ (346)
	6 (152)	(Pre)-06-45VI24	23 ¹ / ₄ (591)	9 ⁵ / ₈ (245)	13 ⁵ / ₈ (346)
36 (915)	3 (76)	(Pre)-03-45VI36	31 ³ / ₈ (797)	13 (330)	18 ³ / ₈ (467)
	4 (101)	(Pre)-04-45VI36	31 ³ / ₄ (806)	13 ¹ / ₈ (334)	18 ⁵ / ₈ (473)
	6 (152)	(Pre)-06-45VI36	31 ³ / ₄ (806)	13 ¹ / ₈ (334)	18 ⁵ / ₈ (473)
48 (1218)	3 (76)	(Pre)-03-45VI48	39 ⁷ / ₈ (1013)	16 ¹ / ₂ (419)	23 ³ / ₈ (594)
	4 (101)	(Pre)-04-45VI48	40 ³ / ₈ (1026)	16 ³ / ₄ (425)	23 ⁵ / ₈ (600)
	6 (152)	(Pre)-06-45VI48	40 ³ / ₈ (1026)	16 ³ / ₄ (425)	23 ⁵ / ₈ (600)

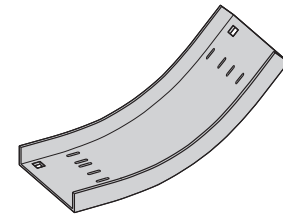

45° Vertical Inside Bend
Ventilated Vertical Inside Bend

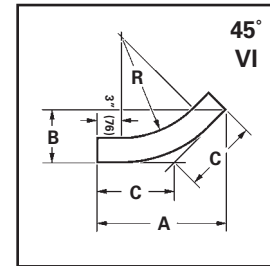

30° Vertical Inside Bend					
Bend Radius R	Tray Width	30° Vertical Inside Bend Dimensions			
		Catalog No.	A	B	C
in. (mm)	in. (mm)		in. (mm)	in. (mm)	in. (mm)
12 (305)	3 (76)	(Pre)-03-30VI12	12 ¹ / ₈ (308)	3 ¹ / ₈ (83)	6 ¹ / ₂ (165)
	4 (101)	(Pre)-04-30VI12	12 ³ / ₈ (314)	3 ³ / ₈ (86)	6 ⁵ / ₈ (163)
	6 (152)	(Pre)-06-30VI12	12 ³ / ₈ (314)	3 ³ / ₈ (86)	6 ⁵ / ₈ (163)
24 (609)	3 (76)	(Pre)-03-30VI24	18 ¹ / ₈ (461)	4 ³ / ₄ (121)	9 ³ / ₄ (248)
	4 (101)	(Pre)-04-30VI24	18 ³ / ₈ (467)	4 ⁷ / ₈ (124)	9 ⁷ / ₈ (251)
	6 (152)	(Pre)-06-30VI24	18 ³ / ₈ (467)	4 ⁷ / ₈ (124)	9 ⁷ / ₈ (251)
36 (915)	3 (76)	(Pre)-03-30VI36	24 ¹ / ₄ (616)	6 ¹ / ₂ (165)	13 (330)
	4 (101)	(Pre)-04-30VI36	24 ¹ / ₂ (622)	6 ⁵ / ₈ (168)	13 ¹ / ₈ (334)
	6 (152)	(Pre)-06-30VI36	24 ¹ / ₂ (622)	6 ⁵ / ₈ (168)	13 ¹ / ₈ (334)
48 (1218)	3 (76)	(Pre)-03-30VI48	30 ³ / ₈ (772)	8 ¹ / ₈ (207)	16 ¹ / ₄ (413)
	4 (101)	(Pre)-04-30VI48	30 ⁵ / ₈ (778)	8 ¹ / ₄ (210)	16 ³ / ₈ (416)
	6 (152)	(Pre)-06-30VI48	30 ⁵ / ₈ (778)	8 ¹ / ₄ (210)	16 ³ / ₈ (416)

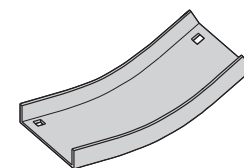

30° Vertical Inside Bend
Non-Ventilated Vertical Inside Bend

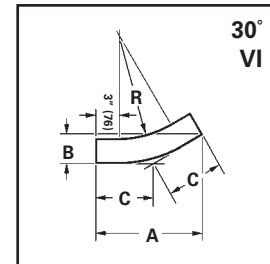

(Pre) See page E-10 for catalog number prefix.

All dimensions in shaded areas are millimeters unless otherwise specified.

Section 1- Acceptable Manufacturers

- 1.01 Manufacturer: Subject to compliance with these specifications, B-Line series channel cable tray systems shall be as manufactured by Eaton.

Section 2- Selection and Components

- 2.01 General: Except as otherwise indicated, provide ventilated metal channel cable trays, of types, classes and sizes indicated with splice connectors, fittings and all other necessary accessories for a complete system. Provide channel cable tray with rounded edges and smooth surfaces in compliance with applicable standards, and with the following additional requirements.
- 2.02 Materials and finishes: Material and finishes specifications for each channel cable tray are as follows:
1. Aluminum: Extruded components shall be made from Aluminum Association Alloy 6063. All fabricated parts shall be made from Aluminum Association Alloy 5052.
 2. Pre-Galvanized Steel: Straight sections and fittings shall be made from structural quality mill galvanized 14 gauge steel meeting the properties of ASTM A653SS, coating designation G90.
 3. Hot Dip Galvanized Steel: Straight sections and fittings shall be made from 14 gauge structural quality steel meeting the minimum mechanical properties of ASTM A1011 SS, Grade 33 and shall be hot-dip galvanized after fabrication in accordance with ASTM A123.
All hot dip galvanized after fabrication cable trays must be returned to point of manufacture after coating for inspection, conditioning and labeling.
 4. Stainless Steel: Straight sections and fittings shall be AISI Type [304] [316].
- 2.03 Channel cable tray straight sections shall be constructed with ventilated flat bottom. Ventilating bottom shall be perforated with 2.25" diameter holes and have slots to facilitate the use of cable ties to secure the cables.
- 2.04 Straight sections shall be supplied in standard [12 foot] [10 foot (3 m)] lengths, except where shorter lengths are permitted to facilitate tray assembly as shown on drawings.
- 2.05 Ventilating straight sections shall have splice holes every 12 inches to simplify field modifications.
- 2.06 Channel cable tray width shall be [3] [4] [6] inches with a minimum loading depth of 1¹/₄".
- 2.07 Fittings will have a minimum radius of [12] [24] [36] [48] inches.
- 2.08 Splice plates and hardware shall be included with each straight section and fitting.