

MATERIAL: PRE-GALV. 14 GA. STEEL ASTM A-446 GRADE A, SS4 304 STAINLESS STEEL, SS6 316 STAINLESS STEEL,
HOT DIP GALVANIZED (AFTER FAB) 14 GA. STEEL ASTM A1011 GRADE 33
.125 ALUMINUM ALLOY 6063-T6

FINISHES: PRE-GALV. ASTM A-525 G-90
HOT-DIP GALV. ASTM A-123

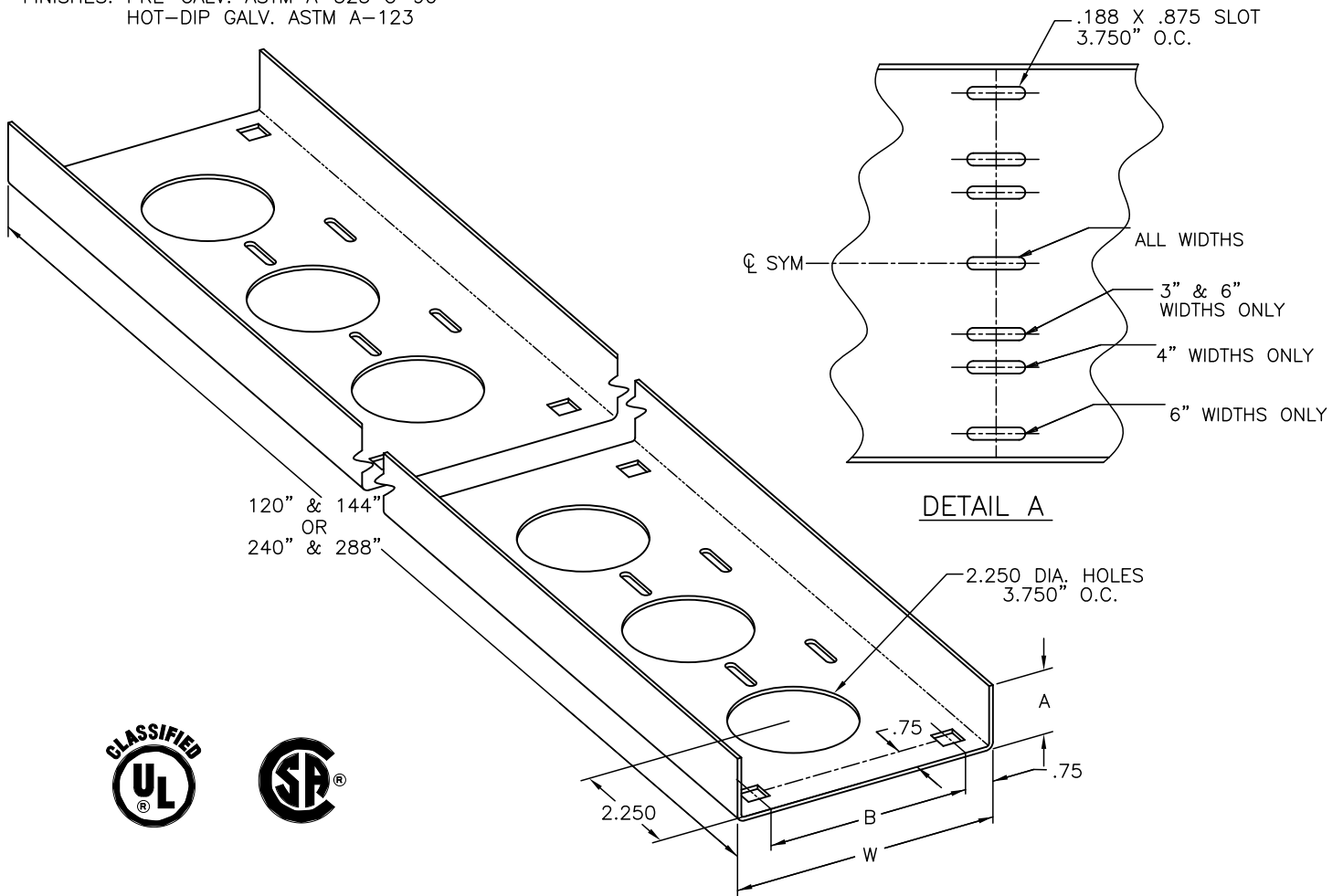

120" & 144"
OR
240" & 288"

DETAIL A



SAFETY FACTOR = 1.5

B-LINE SERIES	WIDTH	A	B	SPAN (FT.)	2	4	6	8	10	12	14
ACC	3	1.25	1.5	LOAD LBS./FT.	131.6	32.9	14.6	8.2	5.2	3.6	2.6
				DEFLECTION IN.	0.08	0.33	0.75	1.33	2.08	3.00	4.08
	4	1.75	2.5	LOAD LBS./FT.	293.8	73.4	32.6	18.3	11.7	8.1	5.9
				DEFLECTION IN.	0.05	0.21	0.48	0.86	1.34	1.93	2.62
	6	1.75	4.5	LOAD LBS./FT.	332.0	83.0	36.8	20.7	13.2	9.2	6.7
				DEFLECTION IN.	0.05	0.19	0.42	0.75	1.17	1.68	2.29

B-LINE SERIES	WIDTH	A	B	SPAN (FT.)	2	4	6	8	10	12	14
*CC	3	1.25	1.5	LOAD LBS./FT.	148.5	37.1	16.5	9.3	5.9	4.1	3.0
				DEFLECTION IN.	0.05	0.20	0.46	0.82	1.28	1.88	2.51
	4	1.75	2.5	LOAD LBS./FT.	327.6	81.9	36.4	20.4	13.1	9.1	6.7
				DEFLECTION IN.	0.03	0.13	0.30	0.53	0.82	1.19	1.62
	6	1.75	4.5	LOAD LBS./FT.	369.9	92.4	41.1	23.1	14.8	10.2	7.5
				DEFLECTION IN.	0.03	0.11	0.26	0.46	0.72	1.04	1.41

* - INSERT "P" FOR PRE-GALV., SS4 FOR 304 STAINLESS, SS6 FOR 316 STAINLESS OR "G" FOR HOT-DIP GALV.



EATON, B-LINE DIVISION
509 WEST MONROE STREET
HIGHLAND, ILLINOIS 62249-0326
PHONE (618) 654-2184
FAX (618) 654-5499

TITLE: VENTILATED
CABLE CHANNEL

PRODUCT DWG. NO'S:

SHEET OF
DRAWN BY: JDG

EQUIPMENT FURNISHED HAS BEEN FABRICATED
IN ACCORDANCE WITH THIS DRAWING.

DRAWING NO.
S00004842

THIS DRAWING AND/OR THE TECHNICAL INFORMATION CONTAINED HEREON IS THE PROPERTY OF EATON CORPORATION ("EATON"), AND IS ISSUED IN CONFIDENCE FOR EATON ENGINEERING PURPOSES ONLY AND MAY NOT BE REPRODUCED OR USED FOR ANY PURPOSE WHATSOEVER WITHOUT THE EXPRESS WRITTEN PERMISSION OF EATON TO THE USER. THIS DRAWING AND/OR TECHNICAL INFORMATION IS THE PROPERTY OF EATON AND IS LOANED FOR MUTUAL ASSISTANCE, TO BE RETURNED WHEN ITS INTENDED PURPOSE HAS BEEN SERVED.

DATE: 10-08-98