

# SOLID BOTTOM CABLE CHANNEL VERTICAL OUTSIDE BENDS

**MATERIAL:**

ALUMINUM 6063-T4 .125"  
 HDGAF ASTM A1011 GR.33 14 GA.  
 STAINLESS STEEL 304 14 GA.  
 STAINLESS STEEL 316 14 GA.

**FINISH:**

HOT DIP GALV. ASTM A123

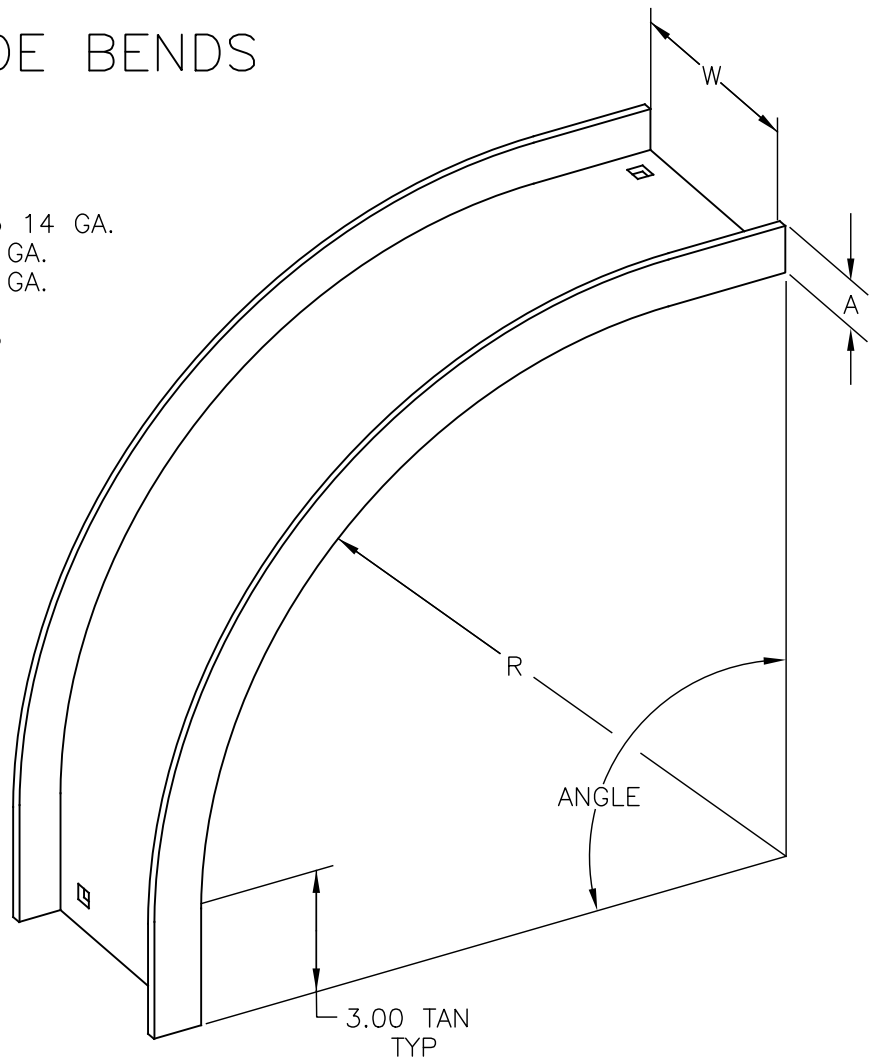

CATALOG NO.	ANGLE	R
*CCN-W-90V012	90°	12 (305)
*CCN-W-90V024		24 (610)
*CCN-W-90V036		36 (915)
*CCN-W-90V048		48 (1220)
*CCN-W-60V012	60°	12 (305)
*CCN-W-60V024		24 (610)
*CCN-W-60V036		36 (915)
*CCN-W-60V048		48 (1220)
*CCN-W-45V012	45°	12 (305)
*CCN-W-45V024		24 (610)
*CCN-W-45V036		36 (915)
*CCN-W-45V048		48 (1220)
*CCN-W-30V012	30°	12 (305)
*CCN-W-30V024		24 (610)
*CCN-W-30V036		36 (915)
*CCN-W-30V048		48 (1220)

W	A
3 (76)	1.25 (32)
4 (102)	1.75 (44)
6 (152)	1.75 (44)

\* INSERT - A FOR ALUMINUM  
 G FOR HDGAF  
 SS4 FOR 304 STAINLESS STEEL  
 SS6 FOR 316 STAINLESS STEEL

W INSERT WIDTH - 03, 04, OR 06

X - ITEMS INCLUDED IN THIS SUBMITTAL

NOTE: DIMENSIONS IN PARENTHESIS ARE  
 IN MILLIMETERS.



EATON, B-LINE DIVISION  
 509 WEST MONROE STREET  
 HIGHLAND, ILLINOIS 62249-0326  
 PHONE (618) 654-2184  
 FAX (618) 654-5499

TITLE: SOLID BOTTOM  
 CABLE CHANNEL  
 VERTICAL OUTSIDE BEND

PRODUCT DWG. NO'S:

SHEET OF  
 DRAWN BY: TJC

EQUIPMENT FURNISHED HAS BEEN FABRICATED  
 IN ACCORDANCE WITH THIS DRAWING.

DRAWING NO.  
 S00007118-S2

THIS DRAWING AND/OR THE TECHNICAL INFORMATION CONTAINED HEREON IS THE PROPERTY OF EATON CORPORATION ("EATON"), AND IS ISSUED IN CONFIDENCE FOR EATON ENGINEERING PURPOSES ONLY AND MAY NOT BE REPRODUCED OR USED FOR ANY PURPOSE WHATSOEVER WITHOUT THE EXPRESS WRITTEN PERMISSION OF EATON TO THE USER. THIS DRAWING AND/OR TECHNICAL INFORMATION IS THE PROPERTY OF EATON AND IS LOANED FOR MUTUAL ASSISTANCE, TO BE RETURNED WHEN ITS INTENDED PURPOSE HAS BEEN SERVED.

DATE: 6/5/96