

FLANGED CABLE CHANNEL
COVER – VERTICAL BENDS

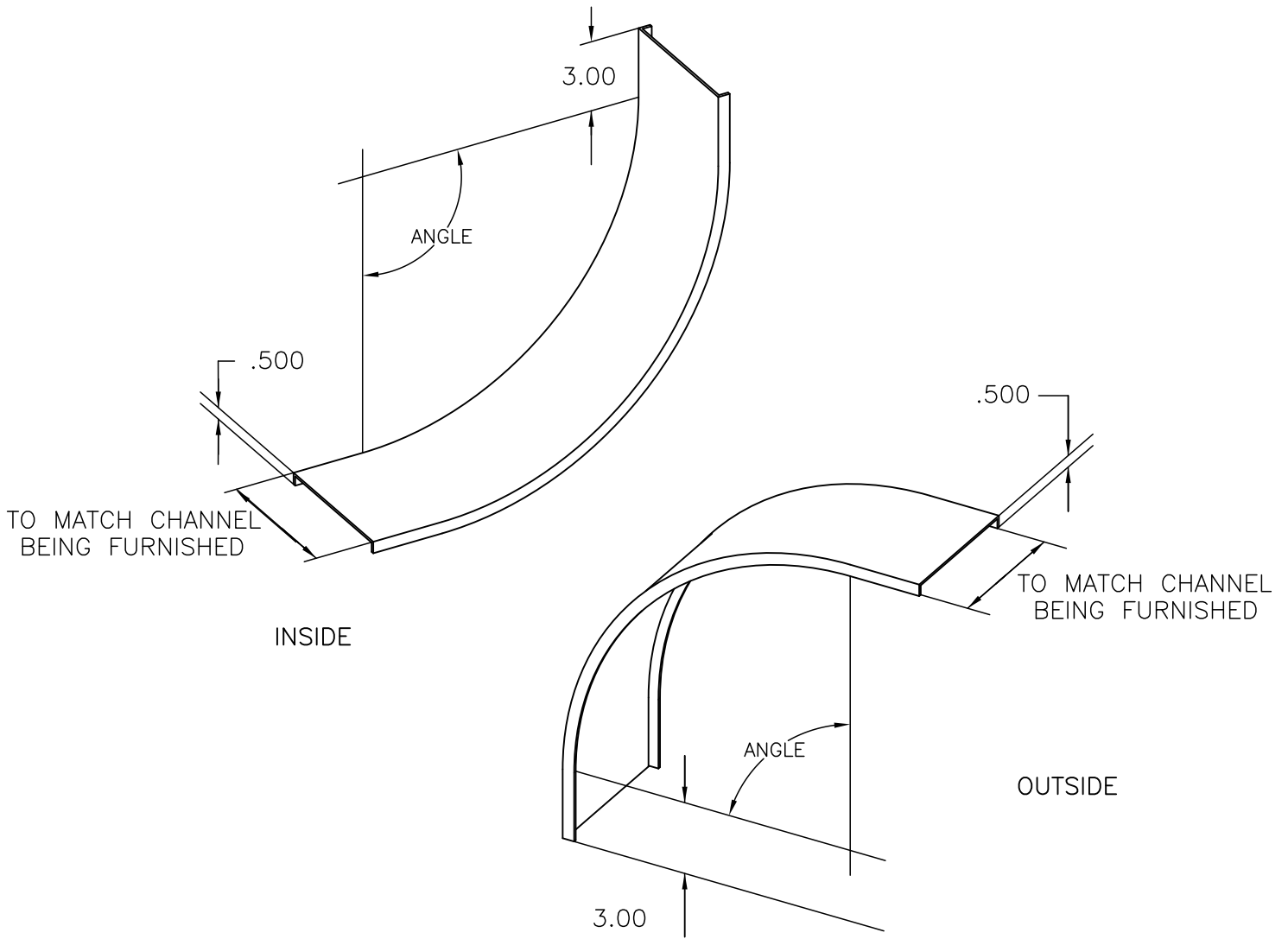

COVER TYPE	DETAIL	MATERIAL	WIDTH (INCHES)	ANGLE	BEND TYPE	RADIUS
80	8=FLANGED STEEL FITTINGS	A=ALUMINUM P=PRE-GALVANIZED G=HOT-DIPPED GALV. AFTER FABRICATION SS4=304 STAINLESS STEEL SS6=316 STAINLESS STEEL	03 04 06	90 60 45 30	VI=INSIDE VO=OUTSIDE	12 24 36



EATON, B-LINE DIVISION
509 WEST MONROE STREET
HIGHLAND, ILLINOIS 62249-0326
PHONE (618) 654-2184
FAX (618) 654-5499

TITLE:

FLANGED VERTICAL
BEND COVER

PRODUCT DWG. NO'S:

SHEET OF

DRAWN BY:

MM

DRAWING NO.
S00004117

DATE: 2/23/04

EQUIPMENT FURNISHED HAS BEEN FABRICATED
IN ACCORDANCE WITH THIS DRAWING.

THIS DRAWING AND/OR THE TECHNICAL INFORMATION CONTAINED HEREON IS THE PROPERTY OF EATON CORPORATION ("EATON"), AND IS ISSUED IN CONFIDENCE FOR EATON ENGINEERING PURPOSES ONLY AND MAY NOT BE REPRODUCED OR USED FOR ANY PURPOSE WHATSOEVER WITHOUT THE EXPRESS WRITTEN PERMISSION OF EATON TO THE USER. THIS DRAWING AND/OR TECHNICAL INFORMATION IS THE PROPERTY OF EATON AND IS LOANED FOR MUTUAL ASSISTANCE, TO BE RETURNED WHEN ITS INTENDED PURPOSE HAS BEEN SERVED.