

CATALOG NO.	A	B	MATERIAL
9A-1261-3	1.500	3.000	.125 ALUM
9A-1261-4	2.500	4.000	.125 ALUM
9A-1261-6	4.500	6.000	.125 ALUM
9*-1261-3	1.500	3.000	12 GA. STEEL
9*-1261-4	2.500	4.000	12 GA. STEEL
9*-1261-6	4.500	6.000	12 GA. STEEL

- * P = PRE-GALV
- G = HDGAF
- S = PLAIN STEEL
- SS4 = STAINLESS STEEL 304
- SS6 = STAINLESS STEEL 316
- YZN = YELLOW ZINC
- FB = FLAT BLACK
- CW = COMPUTER WHITE
- TG = TELCO GRAY
- BZN = BLACK ZINC

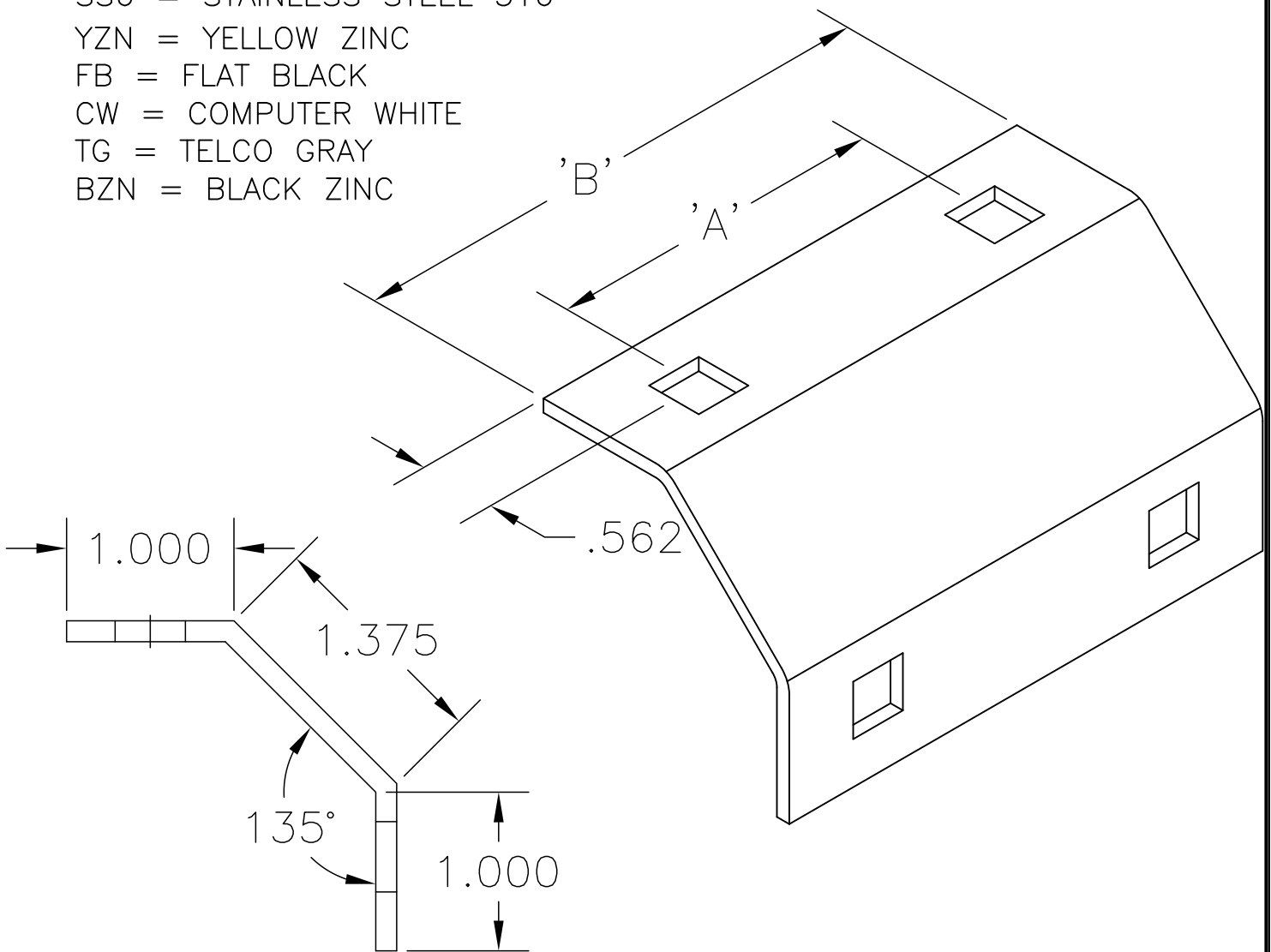

EATON, B-LINE DIVISION
 509 WEST MONROE STREET
 HIGHLAND, ILLINOIS 62249-0326
 PHONE (618) 654-2184
 FAX (618) 654-5499

TITLE: TRAY TO CHANNEL
 CONNECTOR

PRODUCT DWG. NO'S:

SHEET OF
 DRAWN BY: DR

EQUIPMENT FURNISHED HAS BEEN FABRICATED
 IN ACCORDANCE WITH THIS DRAWING.

DRAWING NO.
 S00004275

THIS DRAWING AND/OR THE TECHNICAL INFORMATION CONTAINED HEREON IS THE PROPERTY OF EATON CORPORATION ("EATON"), AND IS ISSUED IN CONFIDENCE FOR EATON ENGINEERING PURPOSES ONLY AND MAY NOT BE REPRODUCED OR USED FOR ANY PURPOSE WHATSOEVER WITHOUT THE EXPRESS WRITTEN PERMISSION OF EATON TO THE USER. THIS DRAWING AND/OR TECHNICAL INFORMATION IS THE PROPERTY OF EATON AND IS LOANED FOR MUTUAL ASSISTANCE, TO BE RETURNED WHEN ITS INTENDED PURPOSE HAS BEEN SERVED.

DATE: 9/9/03