

# WRAP AROUND COVER CLAMP FOR CABLE CHANNEL 9\*-903\*

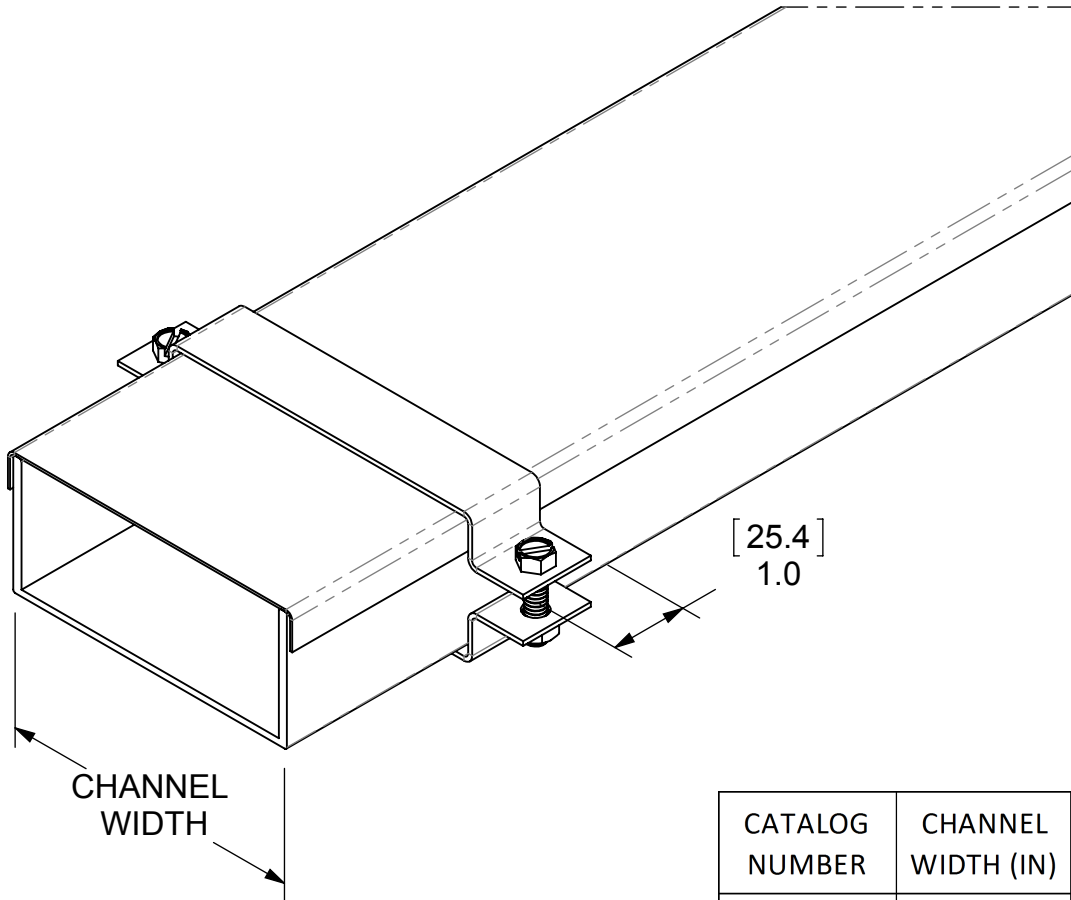

CATALOG NUMBER	CHANNEL WIDTH (IN)	CHANNEL WIDTH (MM)
9*-9033	3	75
9*-9034	4	100
9*-9036	6	150

**HARDWARE:**  
 1/4-20 x 3/4" HHMS - 2 PC.  
 1/4-20 HEX NUT - 2 PC.

\* - P = PRE-GALVANIZED STEEL  
 A = ALUMINUM  
 G = HOT-DIP GALVANIZED  
 SS4 = 304 STAINLESS STEEL  
 SS6 = 316 STAINLESS STEEL

THIS DRAWING AND/OR THE TECHNICAL INFORMATION CONTAINED HEREON IS THE PROPERTY OF EATON CORPORATION ("EATON"), AND IS ISSUED IN CONFIDENCE FOR EATON ENGINEERING PURPOSES ONLY AND MAY NOT BE REPRODUCED OR USED FOR ANY PURPOSE WHATSOEVER WITHOUT THE EXPRESS WRITTEN PERMISSION OF EATON TO THE USER. THIS DRAWING AND/OR TECHNICAL INFORMATION IS THE PROPERTY OF EATON AND IS LOANED FOR MUTUAL ASSISTANCE. TO BE RETURNED WHEN ITS INTENDED PURPOSE HAS BEEN SERVED.

<b>Eaton</b> <i>Powering Business Worldwide®</i>  Eaton, B-Line Division 509 W. Monroe Street Highland, IL 62249 Phone (618) 654-2184 FAX (618) 654-5499  www.b-line.com	SUBMITTAL DRAWING	REFERENCE DWG(S):	SUBMITTAL NO: <b>S00003672</b>
	TITLE:		DRAWN BY:   REV.:
	WRAP AROUND COVER CLAMP FOR CABLE CHANNEL		AMF   B
	UNLESS OTHERWISE SPECIFIED MATERIAL SHOWN HAS BEEN FABRICATED IN ACCORDANCE WITH THIS DRAWING.	MODEL SOURCE FILE:   REV.:	DATE: <b>3/21/2017</b>
	00003672   00	SHEET: <b>1 OF 1</b>	