

SPLICE PLATE FOR STEEL CABLE CHANNEL

PART NO.	WIDTH	A	B
9*-1043	3	1.500	.625
9*-1044	4	2.500	1.125
9*-1044-6	6	4.500	1.125

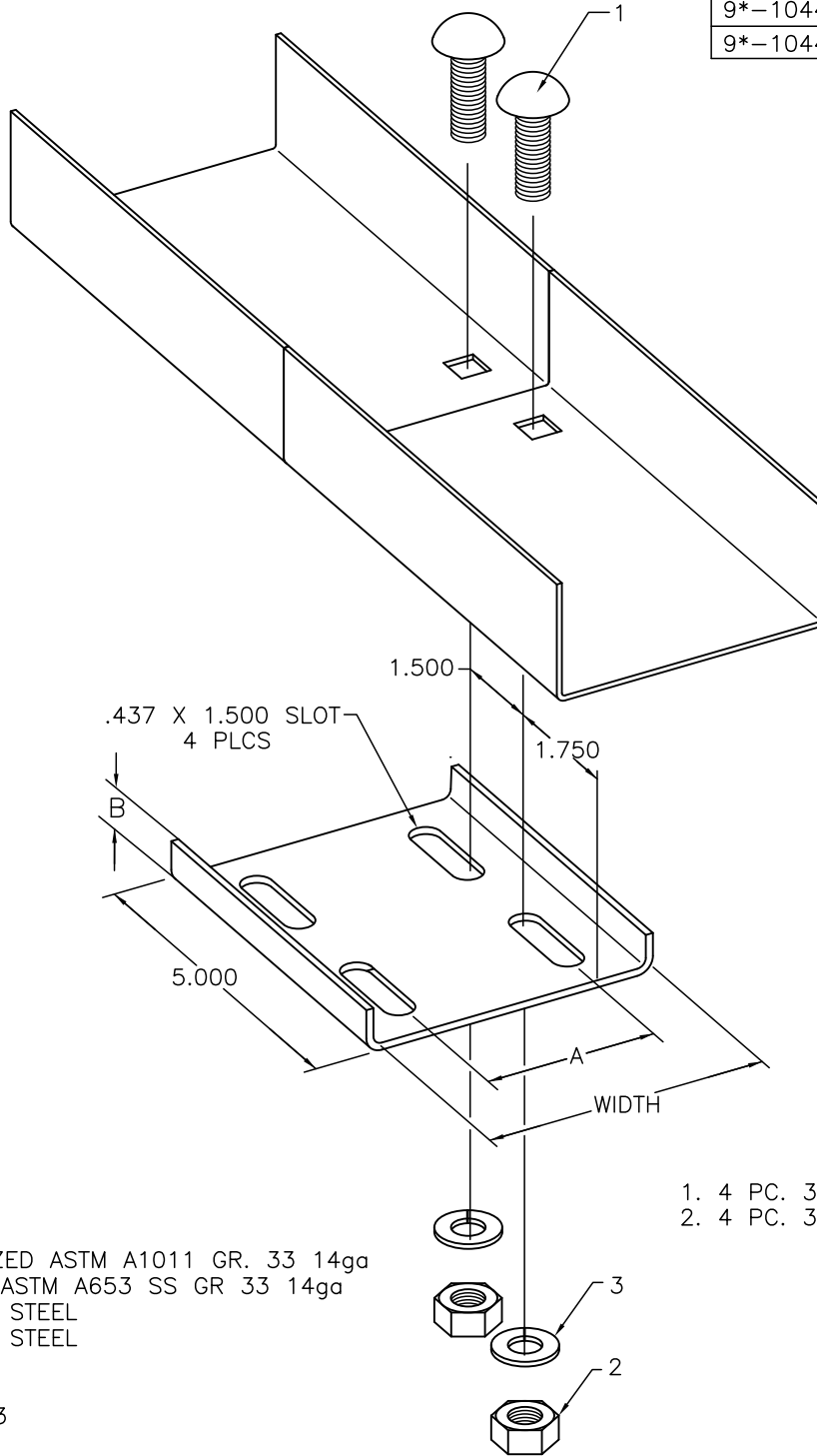

1. 4 PC. 3/8-16 X 3/4 CARRIAGE BOLT
2. 4 PC. 3/8 SFHN

MATERIAL:

G - HOT DIP GALVANIZED ASTM A1011 GR. 33 14ga
 P - PRE-GALVANIZED ASTM A653 SS GR 33 14ga
 SS4 - 304 STAINLESS STEEL
 SS6 - 316 STAINLESS STEEL

FINISH:

G - HDGAF ASTM A123



EATON, B-LINE DIVISION
 509 WEST MONROE STREET
 HIGHLAND, ILLINOIS 62249-0326
 PHONE (618) 654-2184
 FAX (618) 654-5499

TITLE: SPLICE PLATE
FOR STEEL
CABLE CHANNEL

PRODUCT DWG. NO'S:

BLH-00001258

SHEET OF

DRAWN BY: TJC

EQUIPMENT FURNISHED HAS BEEN FABRICATED
IN ACCORDANCE WITH THIS DRAWING.

DRAWING NO.
S00001258

THIS DRAWING AND/OR THE TECHNICAL INFORMATION CONTAINED HEREON IS THE PROPERTY OF EATON CORPORATION ("EATON"), AND IS ISSUED IN CONFIDENCE FOR EATON ENGINEERING PURPOSES ONLY AND MAY NOT BE REPRODUCED OR USED FOR ANY PURPOSE WHATSOEVER WITHOUT THE EXPRESS WRITTEN PERMISSION OF EATON TO THE USER. THIS DRAWING AND/OR TECHNICAL INFORMATION IS THE PROPERTY OF EATON AND IS LOANED FOR MUTUAL ASSISTANCE, TO BE RETURNED WHEN ITS INTENDED PURPOSE HAS BEEN SERVED.

DATE: 8/11/97