

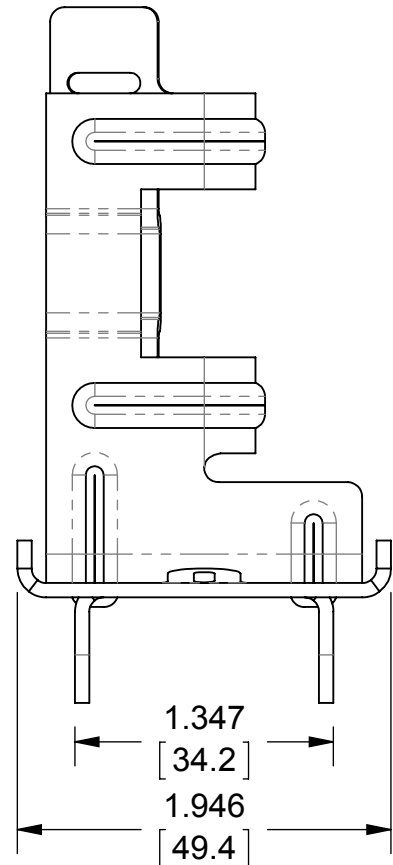

PART NUMBER	ØA
4D5000-3/8	0.375
4D5000-1/2	0.500

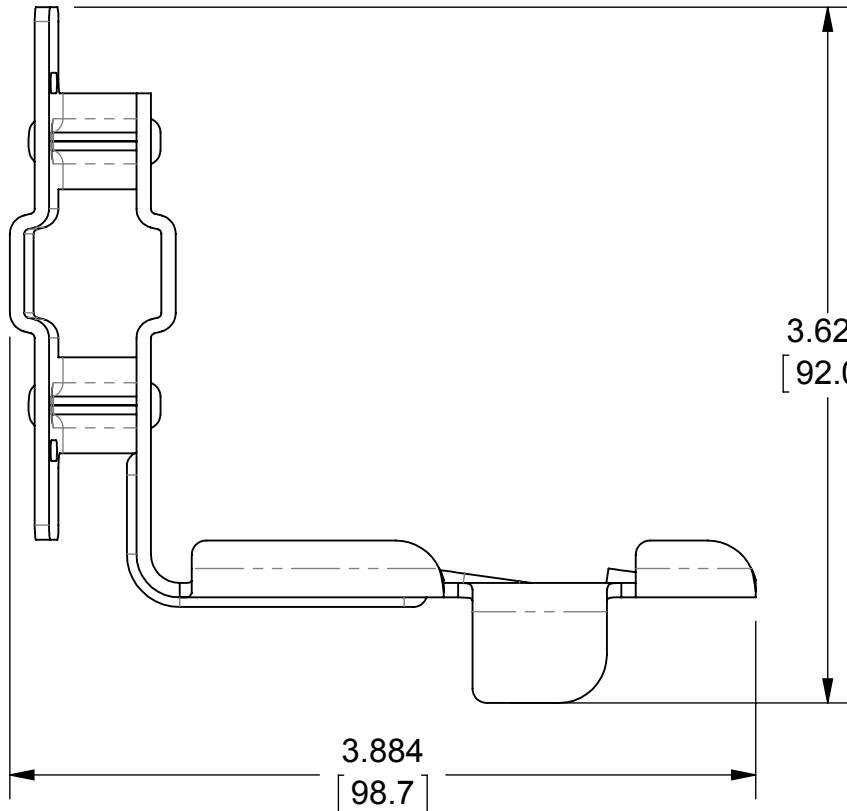
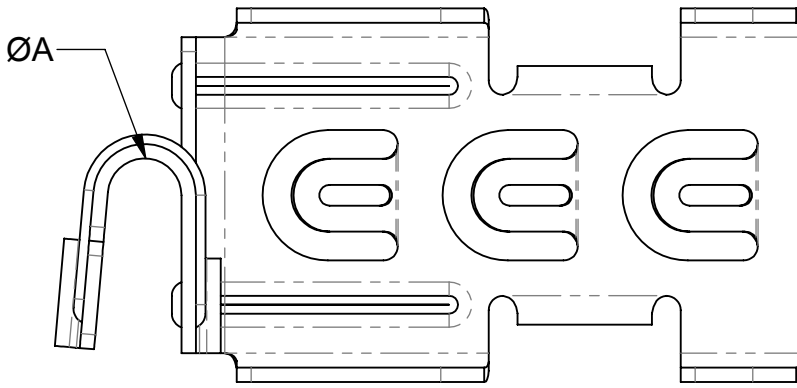
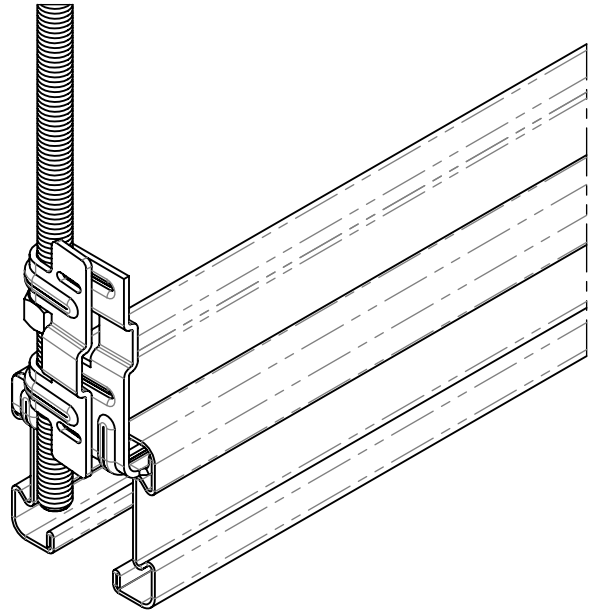

THIS DRAWING AND/OR THE TECHNICAL INFORMATION CONTAINED HEREON IS THE PROPERTY OF COOPER B-LINE, INC. ("B-LINE"), AND IS ISSUED IN CONFIDENCE FOR B-LINE ENGINEERING PURPOSES ONLY AND MAY NOT BE REPRODUCED OR USED FOR ANY PURPOSE WHATSOEVER WITHOUT THE EXPRESS WRITTEN PERMISSION OF B-LINE TO THE USER. THIS DRAWING AND/OR TECHNICAL INFORMATION IS THE PROPERTY OF B-LINE AND IS LOANED FOR MUTUAL ASSISTANCE. TO BE RETURNED WHEN ITS INTENDED PURPOSE HAS BEEN SERVED.

 509 W. Monroe Street Highland, IL 62249 Phone (618) 654-2184 FAX (618) 654-5499 www.cooperbline.com	SUBMITTAL DRAWING		REFERENCE DWG(S):	SUBMITTAL NO:
	TITLE:  4D FLIP CLIP 4D5000		27162	S00027162
			MODEL SOURCE FILE:	DATE:
			00027162	10/31/14
		REV:	SHEET:	
			1 OF 1	
EQUIPMENT FURNISHED HAS BEEN FABRICATED IN ACCORDANCE WITH THIS DRAWING.				